

FOSVOS GM6802-3

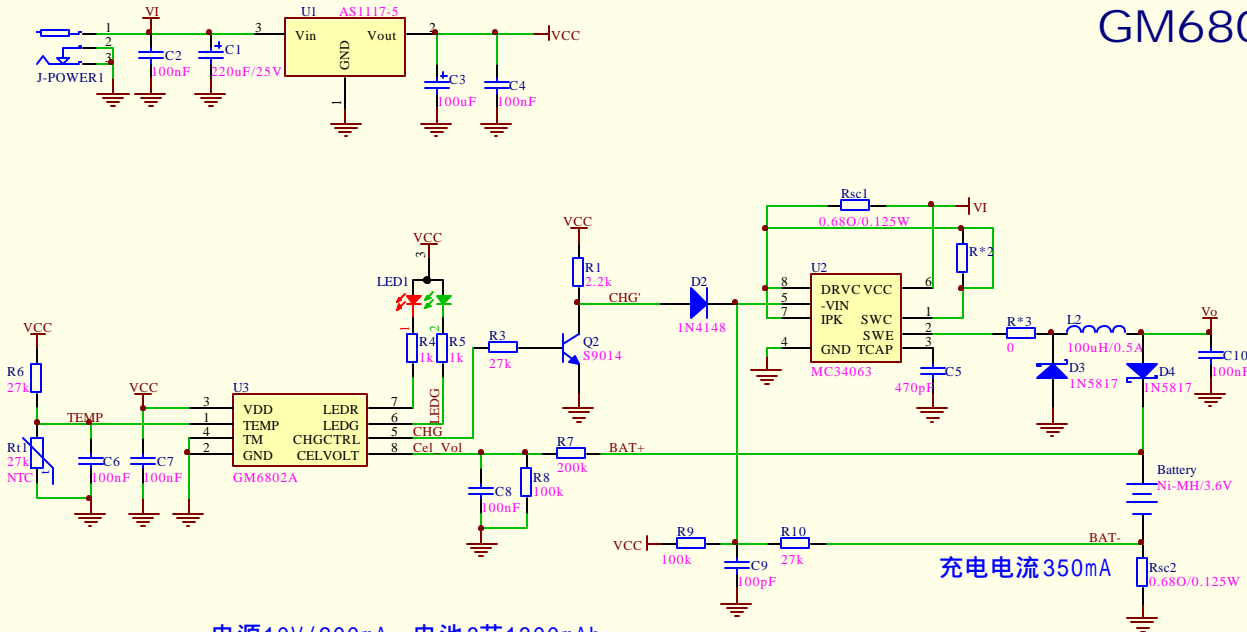

电源10V/200mA，电池3节1300mAh

充电电流350mA

图中参数对应充电电流约为350mA，总输入电流约为250mA，
如果超出了所能容忍的范围，请调整相关元件的参数。
可将R9换成56k，R10换成16k，此时充电电流约260mA。

$$I(\text{chg}) = (1.25 - 3.75 / R9 * R10) / Rsc2 \dots\dots (R10 > 3 * R1)$$

Title *			
Designed By:		Size: A4	REFNO:
Checked By:		VER:	Sheet of

