



CYT2708 Series Step-up DC-DC Converter

Description

CYT2708 Series is a PFM Step-up DC/DC converter IC with low supply current by CMOS process. High frequency noise that occurs during switching is reduced by using advanced circuit designed, output voltage is programmable in 0.1V steps between 2.0~7.0V and maximum frequency is 180KHz(Typ.). A low ripple, high efficiency step-up DC/DC converter can be constructed of CYT2708Xxx with only three external components. Also available is a CE(chip enable) function that reduce power dissipation During shut-down mode. CYT2708Xxx is suitable for use with battery-powered instruments with low noise and low supply current.

Features

- Low ripple and low noise ;
- Operating voltage range : 0.9V~8V ;
- Output voltage range : 2.0V~7.0V(step 0.1V) ;
- Output voltage accuracy : $\pm 2.5\%$;
- Output Current : if $V_{in}=3.0V$ and $V_{out}=5.0V$, then $I_{out}=400mA$;
- Low start voltage : $\leq 0.9V$ (at $I_{out}=1mA$) ;
- Maximum oscillator frequency : 180KHz(Typ.) ;
- High Efficiency : 85%(Type) ;
- PACKAGE : SOT23 , SOT89.
- RoHS Compliant and 100% Lead (Pb)-Free

Selection Guide

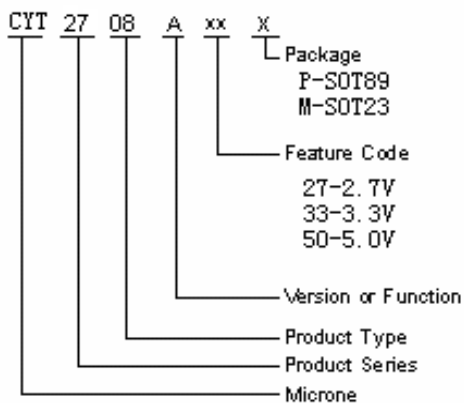

Applications

- Power source for battery-powered equipment ;
- Power source for wireless mouse, wireless keyboard, toys, cameras, camcorders, VCRs, PDAs, and hand-held communication equipment ;
- Power source for appliances which require higher cell voltage than that of batteries used in the appliances .

TYPE	POSTFIX	PACKAGE	SWITCHING TRANSISTOR	CE FUNCTION	FEATURES
CYT2708Axx	M3	SOT23-3	Build_in	No	Lx
	P	SOT89-3	Transistor		
CYT2708Bxx	M3	SOT23-3	External	No	Ext
	P	SOT89-3	Transistor		
CYT2708Cxx	M5	SOT23-5	Build_in	Yes	Lx+CE
	P	SOT89-5	Transistor		
CYT2708Dxx	M5	SOT23-5	External	Yes	Ext+CE
	P	SOT89-5	Transistor		
CYT2708Fxx	M5	SOT23-5	External Transistor	Yes	Ext



Pin Assignment

CYT2708Axx

PIN Number		PINNAME	FUNCTION
SOT23-3	SOT89-3		
1	1	Vss	Ground
3	2	Vout	Output voltage monitor, IC internal power supply
2	3	Lx	Switch

CYT2708Bxx

PIN Number		PIN NAME	FUNCTION
SOT23-3	SOT89-3		
1	1	Vss	Ground
3	2	Vout	Output voltage monitor, IC internal power supply
2	3	Ext	External switch transistor drive

CYT2708Cxx

PIN Number		PIN NAME	FUNCTION
SOT23-5	SOT89-5		
4	5	Vss	Ground
2	2	Vout	Output voltage monitor, IC internal power supply
5	4	Lx	Switch
1	3	CE	Chip enable
3	1	NC	NC

CYT2708Dxx

PIN Number		PIN NAME	FUNCTION
SOT23-5	SOT89-5		
4	5	Vss	Ground
2	2	Vout	Output voltage monitor, IC internal power supply
5	4	Ext	External switch transistor drive
1	3	CE	Chip enable
3	1	NC	NC

CYT2708Fxx

PIN Number		PIN NAME	FUNCTION
SOT23-5			
1		FB	Feed Back
2		Vdd	Output voltage monitor, IC internal power supply
3		NC	NC
4		Vss	Ground
5		EXT	External switch transistor drive

Block Diagram

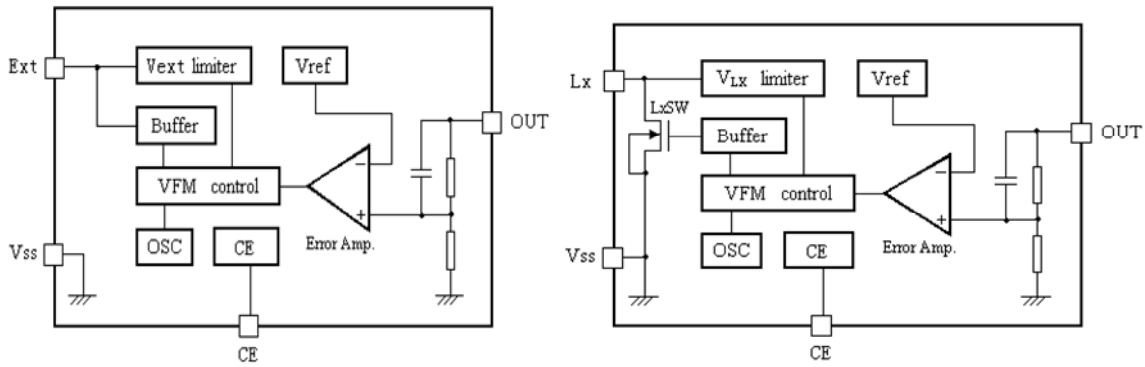

Absolute Maximum Ratings

PARAMETER	SYMBOL	RATINGS	UNITS	
V _{IN} Input Voltage	V _{IN}	10	V	
Lx Pin voltage	V _{LX}	10	V	
EXT Pin voltage	V _{EXT}	-0.3~V _{out} +0.3	V	
CE Pin voltage	V _{CE}	-0.3~V _{out} +0.3	V	
Lx Pin current	I _{LX}	600	mA	
EXT Pin current	I _{EXT}	±30	mA	
V _{dd} input voltage	V _{dd}	10	V	
Continuous Total Power Dissipation	SOT23	P _d	300	mW
	SOT89	P _d	500	mW
Operating Ambient Temperature	T _{Opr}	-25~+85	°C	
Storage Temperature	T _{stg}	-40~+125	°C	
Soldering temperature and time	T _{solder}	260°C, 10s		

**Electrical Characteristics**

Measuring conditions : Unless otherwise specified , $V_{IN}=V_{out}*0.6$, $V_{SS}=0V$, $I_{OUT}=10mA$, $T_{opt}=25^{\circ}C$.

CYT2708Axx/Cxx $F_{osc}=180kHz$

SYMB-OL	PARAMETER	CONDITIONS	MIN	TYP	MAX	UNITS
V_{OUT}	Output Voltage		$V_{out}*0.975$	V_{out}	$V_{out}*1.025$	V
V_{start}	Oscillation Start-up Voltage	$I_{OUT}=1mA$, $V_{IN} : 0 \rightarrow 2V$		0.8	0.9	V
V_{hold}	Oscillation Hold Voltage	$I_{OUT}=1mA$, $V_{IN} : 2 \rightarrow 0V$		0.45		V
I_{DD1}	Supply Current 1	No external component $V_{out}=V_{out}*0.95$,		80		μA
I_{DD2}	Supply Current 2	$V_{out}=V_{out}+0.5V$		10		μA
I_{LX}	Lx Switching Current	$V_{LX}=0.4V$, $V_{out}=V_{out}*0.95$		360		mA
I_{LXleak}	Lx Leakage Current	$V_{out}=V_{LX}=6V$			0.5	μA
F_{osc}	Oscillation Frequency	$V_{out}=\text{set } V_{out}*0.95$		180		kHz
Maxdty	Duty Ratio	on(V_{LX} “L”)side		84		%
EFFI	Efficiency			85		%

CYT2708Bxx/Dxx $F_{osc}=180kHz$

SYMB-OL	PARAMETER	CONDITIONS	MIN	TYP	MAX	UNITS
V_{OUT}	Output Voltage		$V_{out}*0.975$	V_{out}	$V_{out}*1.025$	V
V_{start}	Oscillation Start-up Voltage	$I_{OUT}=1mA$, $V_{IN} : 0 \rightarrow 2V$		0.8	0.9	V
V_{hold}	Oscillation Hold Voltage	$I_{OUT}=1mA$, $V_{IN} : 2 \rightarrow 0V$		0.45		V
I_{DD1}	Supply Current 1	No external component $V_{out}=V_{out}*0.95$,		80		μA
I_{DD2}	Supply Current 2	$V_{out}=V_{out}+0.5V$		10		μA
I_{LX}	Lx Switching Current	$V_{LX}=0.4V$, $V_{out}=V_{out}*0.95$		360		mA
I_{LXleak}	Lx Leakage Current	$V_{out}=V_{LX}=6V$			0.5	μA
F_{osc}	Oscillation Frequency	$V_{out}=\text{set } V_{out}*0.95$		180		kHz
Maxdty	Duty Ratio	on(V_{LX} “L”)side		84		%
EFFI	Efficiency			85		%



CYT2708F VFB=3.3V , Fosc=180kHz

SYMB-OL	PARAMETER	CONDITIONS	MIN	TYP	MAX	UNITS
V _{FB}	Output Feedback Voltage		3.22	3.3	3.38	V
V _{start}	Oscillation Start-up Voltage	I _{OUT} =1mA , V _{IN} : 0→2V		0.8	0.9	V
V _{hold}	Oscillation Hold Voltage	I _{OUT} =1mA , V _{IN} : 2→0V		0.45		V
I _{DD1}	Supply Current 1	No external component V _{out} =V _{out} *0.95,		80		μA
I _{DD2}	Supply Current 2	V _{out} =V _{out} +0.5V		10		μA
I _{LX}	Lx Switching Current	V _{LX} =0.4V, V _{out} =V _{out} *0.95		360		mA
I _{LXleak}	Lx Leakage Current	V _{out} =V _{LX} =6V			0.5	μA
F _{osc}	Oscillation Frequency	V _{out} =set V _{out} *0.95		180		kHz
Maxdty	Duty Ratio	on(V _{LX} "L")side		84		%
EFFI	Efficiency			85		%

Note : 1、Diode use Schottky diode such as IN5817 or IN5819 (forward voltage drop:0.2V)

2、Inductor : 33 μH (r<0.5Ω)

3、Capacitor : Tantalum type 100 μF

Operation

CYT2708 step-up DC/DC converter charges energy in the inductor when Lx Transistor is on, and discharges the energy with the addition of the energy from input power source thereto, so that a higher output voltage than the input voltage is obtained. Following is the operation diagram.

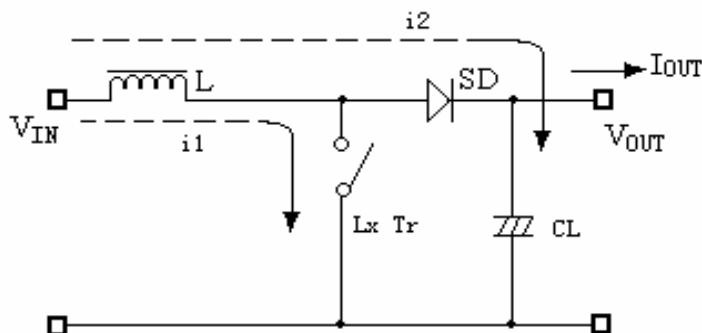

Switching DC/DC Step up Converter operating process



Selection of Peripheral Components and Application Notes

Peripheral components should be selected carefully because they are greatly affect the performances of CYT2708 :

- Use capacitor with a capacity of 10 μ F or more (too small capacity will lead to high output ripple), and with good frequency characteristics (it is better to use Tantalum type). Besides, it is recommended the use of a capacitor with an allowable voltage which is at least three times the output set voltage. This is because there may be the case where a spike-shaped high voltage is generated by the inductor when Lx transistor is turned OFF.
- Choose such an inductor that has sufficiently small d.c. resistance and large allowable current, and hardly reaches magnetic saturation. When the inductance value of the inductor is small, there may be the case where I_{LX} exceeds the absolute maximum ratings at the maximum load.
- Use a diode of a Schottky type with high switching speed.

Notes :

- Set external components as close as possible to the IC and minimize the connection between the components and the IC. In particular, when an external component is connected to V_{OUT} Pin, make minimum connection with the capacitor.
- Make V_{SS} pin sufficient grounding, otherwise, the zero level within IC will varied with the switching current. This may result in unstable operation of IC.

Pin Configuration

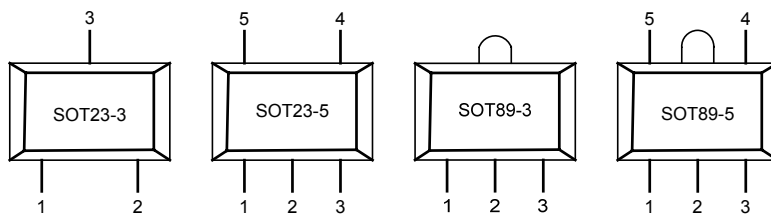

Typical Applications

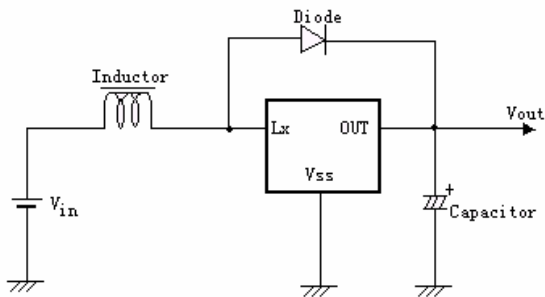

For use Build_in Transistor

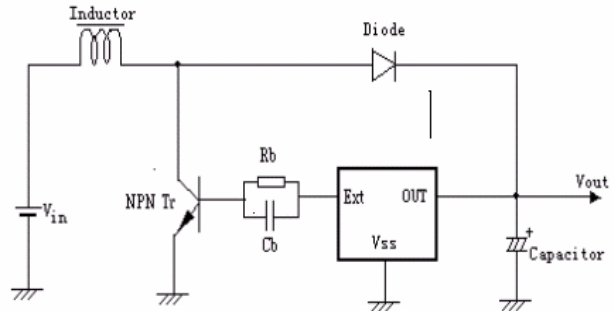

For use External Transistor

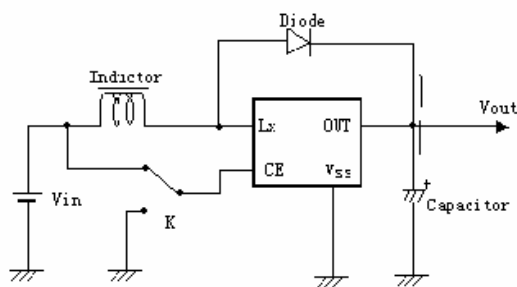

For use Chip Enable(CE)

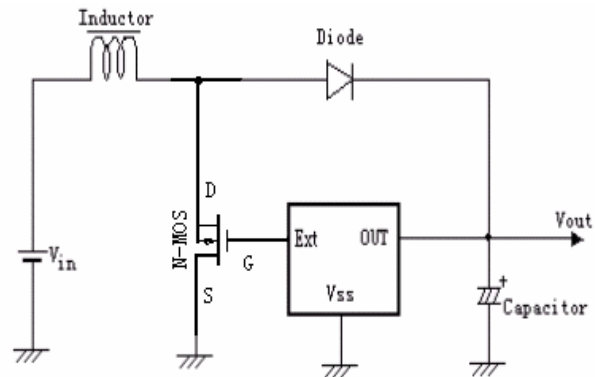

For use external transistor(N_MOS)

Components : Inductor : 47uH(Sumida)

Capacitor : 47uF/16V(Tantalume type)

NMOS : AAT9460 、XP151 、XP161

Base Capacitor(Cb) : 2200pF

R_{FB} :Set up so that $R_{FB1} / R_{FB2} = V_{out} / V_{FB} - 1$ (V_{out} =set-up output voltage),

Please use with $R_{FB1} + R_{FB2} \leq 2M\Omega$;

C_{FB} :Set up that $F_{zfb} = 1 / (2 \times \pi \times C_{FB} \times R_{FB1})$ is within the Adjustments necessary in respect of L, C_L .

Diode : IN5817 、IN5819

Transistor : 2SD1628G 、2SD3279

Base Resistor(R_b) : 1K Ω

Package Diomensions

