

GENERAL DESCRIPTION

CM6901 is a SLS, SRC/LLC + SR resonant controller and it can operate at both SRC and LLC region with synchronous rectification to achieve high efficiency. Its unique features: FM + 2 PWMING modes. It is used for DC-DC conversion in offline application. Light load regulation is accomplished by transitioning the controller from frequency modulation mode into PWM mode. To have the optimal balance performance between hold-up time and efficiency, its frequency range crosses f_{r1} , resonant frequency.

CM6901 system has a constant voltage feedback loop with precision 2.5V Vfb reference. The 1V I LIMIT can be latched when a standby converter is applied; otherwise, it is an auto-restart I limit.

FEATURES

- ◆ 90+ Controller
- ◆ Smaller and Thinner Transformer
- ◆ 20mS with reasonable Bulk Cap
- ◆ SLS, SRC/LLC + SR resonant controller
- ◆ Supply Voltage Range : 10V to 15V.
- ◆ 2 Gate Drivers: Typical Peak Drive from 12V supply : (PMOS~200 ohm and NMOS~100 ohm).
- ◆ UVLO=11V with 1V Hysteresis.
- ◆ Reference OK Comparator.
- ◆ FM + 2 PWMING Mode Operation
- ◆ Light Load PWMING
- ◆ SR Ideal Diode PWMING
- ◆ GM feao, FM modulation Error Amplifier
- ◆ GM deao, PWM Error Amplifier
- ◆ Close Loop Soft start Capability with Shutdown Function.
- ◆ Auto-Restart during Current Limit .
- ◆ Precision 2.5V Vfb threshold for constant voltage feedback loop.
- ◆ Precision 1V I limit threshold.

APPLICATIONS

- ◆ DC-DC power supply.
- ◆ Operates in FM/PWM mode.

CM6901 Pin Configuration

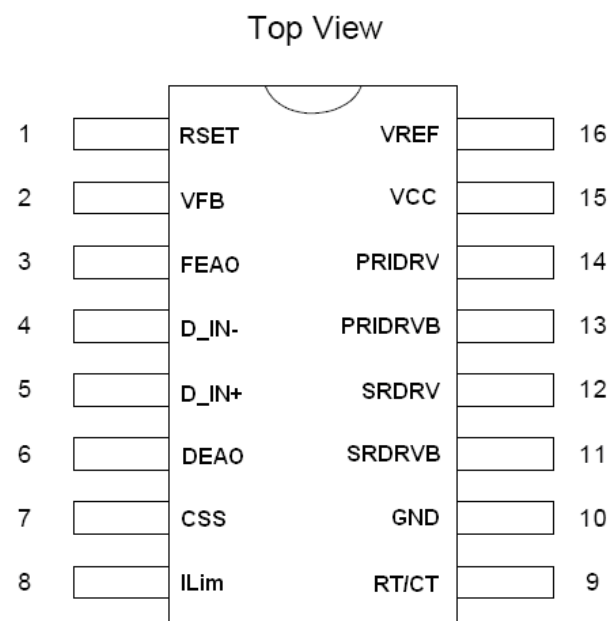

ORDERING INFORMATION

Part Number	Temperature Range	Package
CM6901GIS*	-40°C to 125°C	16-Pin SOP (S16)
CM6901GISTR*	-40°C to 125°C	16-Pin SOP (S16)
CM6901GIP*	-40°C to 125°C	16-Pin PDIP (P16)
CM6901XIS*	-40°C to 125°C	16-Pin SOP (S16)
CM6901XISTR*	-40°C to 125°C	16-Pin SOP (S16)
CM6901XIP*	-40°C to 125°C	16-Pin PDIP (P16)

*Note : G : Suffix for Pb Free Product
 X : Suffix for Halogen Free Product
 TR : Package is Typing Reel

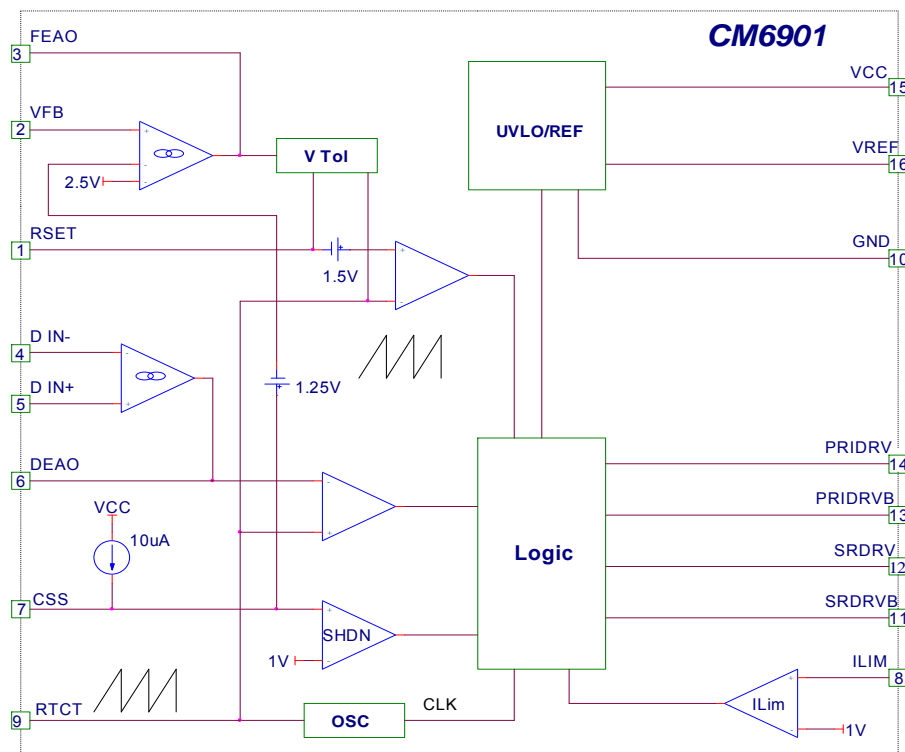
BLOCK DIAGRAM

PIN DESCRIPTION

Pin No.	Symbol	Description	Operating Voltage			
			Min.	Typ.	Max.	Unit
1	RSET	External resistor which convert FEAO voltage signal into current signal for frequency modulation. SR is PWMing Control , when RSET lower than 1.5V.	0		5.5	V
2	VFB	Non-inverting input into resonant error amplifier .	0	2.5	3	V
3	FEAO	Resonant error amplifier output and compensation node for frequency modulation control.	0		5.5	V
4	D_IN-	Inverting input into PWM error amplifier.	0		6	V
5	D_IN+	Non-inverting input into PWM error amplifier.	0		6	V
6	DEAO	PWM error amplifier output and compensation node for PWM control.	0		4.5	V
7	CSS	Soft start for FM/PWM operation with 1V enable threshold. Also, use for auto-restart operation during current limit.	0		5.5	V
8	ILIM	Input to current comparator with 1V threshold.	0	1	1.25	V
9	RTCT	Oscillator timing components which set the minimum frequency.	1.2		3	V
10	GND	Ground				
11	SDRVB	Synchronous MOSFET driver output.	-0.3		VCC	V
12	SDRV	Synchronous MOSFET driver output.	-0.3		VCC	V
13	PRIDRVB	Primary side MOSFET driver output.	-0.3		VCC	V
14	PRIDRV	Primary side MOSFET driver output.	-0.3		VCC	V
15	VCC	Positive supply for the IC	10	15	17.5	V
16	VREF	Buffered output for the 7.5V voltage reference		7.5		V

ABSOLUTE MAXIMUM RATINGS (TA=25°C, unless otherwise specified.)

The following ratings designate persistent limits beyond which damage to the device may occur.

Symbol	Parameter	Value	Unit
VCC	DC Supply Voltage	-0.3 to 20	V
SRDRV	SRDRV Voltage	-0.3 to VCC+0.3	V
SRDRVB	SRDRVB Voltage	-0.3 to VCC+0.3	V
PRIDRV	PRIDRV Voltage	-0.3 to VCC+0.3	V
PRIDRVB	PRIDRVB Voltage	-0.3 to VCC+0.3	V
VREF	VREF Voltage	-0.3 to 7.5	V
RTCT	RTCT Voltage	-0.3 to VREF+0.3	V
VILIM	VILIM Voltage	-0.3 to VREF+0.3	V
CSS	CSS Voltage	-0.3 to VREF+0.3	V
DEAO	PWM Error Amplifier Output Voltage	-0.3 to VREF+0.3	V
D_IN+	Non-Inverting Input Into PWM Error Amplifier Voltage	-0.3 to VREF+0.3	V
FEAO	Resonant Error Amplifier Output Voltage	-0.3 to VREF+0.3	V
VFB	Non-Inverting Input Into Resonant Error Amplifier Voltage	-0.3 to VREF+0.3	V
RSET	V to I Voltage	-0.3 to VREF+0.3	V

ELECTRICAL CHARACTERISTICS

(VCC=12V, RT=43K±1%, CT=820pF±1%, Freq. = 80 KHz, Duty Cycle=48% , Temp= -40 ~ 125 °C, unless otherwise specified.)

Parameter	Symbol	Conditions	Min.	Typ.	Max.	Unit
VREF (pin 16)						
Reference Voltage	VREF	TA=25°C; Iref=1mA	7.41	7.5	7.59	V
Line Regulation		11.5V < Vcc < 16.5V		10	25	mV
Load Regulation		0mA < Iref < 5mA	0	10	25	mV
VCC (pin 15)						
VCC Start up voltage	Vstart		10.23	11	11.5	V
VCC Turn off voltage			9.3	10	10.7	V
VCC Start up current			63.5	74.5	85.5	uA
UVLO Hysteresics	Hyst		0.93	1	1.07	V
Operating Current	ICC			1		mA
SRDRV , SRDRV , PRIDRV , PRIDRV (pin 11,12,13,14)						
Output Low Voltage	Vol	Isdrv=-6mA		0.6	1.2	V
Output High Voltage	Voh	Isdrv=+6mA	9.6	10.8		V
Iout peak source current	Iout			0.12		A
Iout peak sink current	Iout			0.12		A
PMOS Rds(on)	Rout	TA=25°C		200	250	Ohm
NMOS Rds(on)	Rout	TA=25°C		100	150	Ohm
Dead Time between PRIDRV and PRIDRVB	TDead	TA=25°C		650		ns
Rising Edge Delay Between PRIDRV and SRDRV	Tdelay	TA=25°C	175	217.5	260	ns
Falling Edge Delay Between SRDRV and PRIDRV	Tdelay	TA=25°C	178	222.5	267	ns
Duty Cycle Range			0		50	%
ILIM (pin 8)						
Threshold Voltage	Vth	TA=25°C	1.45	1.65	1.75	V
SS Voltage Hi		TA=25°C	0.95	1	1.05	V
SS Voltage Low		TA=25°C	1.31	1.64	1.97	V

ELECTRICAL CHARACTERISTICS

(V_{CC}=12V, R_T=43K±1%, C_T=820pF±1%, Freq. = 80 KHz, Duty Cycle=48% , Temp=-40 ~ 125°C, unless otherwise specified.)

Parameter	Symbol	Conditions	Min.	Typ.	Max.	Unit
CSS (pin 7)						
Soft Start Current	I _{SS}	TA=25°C	-8.7	-7.5	-6.3	uA
Enable Voltage	V _{EN}	TA=25°C	0.9	1.0	1.1	V
Enable Hysteresis	V _{HYST}	TA=25°C		100		mV
Auto-restart Upper Threshold	V _{UP}		4.85	5.0	5.15	V
Auto-restart Lower Threshold	V _{LOW}			1-V _{HYST}		V
FEAO Resonant Error Amplifier (pin 3)						
Input Voltage Range					6	V
Transconductance	G _m	V _{FB} ±50mV, TA=25°C	37	46.5	56	umho
Feedback Reference Voltage		TA=25°C	2.475	2.5	2.525	V
Input Bias Current			-1	-0.5		uA
Output High Voltage				5.5+V _{BE}		V
Output Low Voltage				0.1	0.4	V
Sink Current		V _{FB} =250mV , TA=25°C	-20.4	-17	-13.6	uA
Source Current		V _{FB} = -250mV , TA=25°C	12.4	15.6	18.8	uA
Open Loop Gain				60		dB
DEAO PWM Error Amplifier (pin 6)						
Input Voltage Range					6	V
Reference Voltage			0.96	1.01	1.06	V
Transconductance	G _m	TA=25°C	95	120	145	umho
Input Bias Current			-1.0	-0.5		uA
Output Voltage High				3+V _{BE}		V
Output Voltage Low				0.1	0.4	V
Sink Current				-5		uA
Source Current				7		uA
Open Loop Gain				60		dB

ELECTRICAL CHARACTERISTICS

(Vcc=12V, RT=43K±1%, CT=820pF±1%, Freq. = 80 KHz, Duty Cycle=48% , Temp=-40 ~ 125 °C, unless otherwise specified.)

Parameter	Symbol	Conditions	Min.	Typ.	Max.	Unit
RTCT Oscillator;RT=43K±1%;CT=820pF±1%, (pin 9)						
Initial Accuracy		TA=25°C	72	80	88	Khz
Voltage Stability		11.5V < Vcc < 16.5V		1		%
Temperature Stability				2		%
Ramp Valley to Peak Voltage				2		V
CT Discharge Time				350		nS
Maximum Duty cycle		DEAO > 3.0V		48		%
Minimum Duty Cycle		DEAO < 1.2V		0		%
SR Ideal Diode (pin12)						
Maximum Duty cycle		TA=25°C	35	40	45	%
Middle Duty cycle		TA=25°C	22	24.5	27	%
Minimum Duty cycle		TA=25°C	2.5	4.65	6.8	%
Frequency at Minimum Duty cycle		TA=25°C	36	39	42	KHz

Timing Diagram

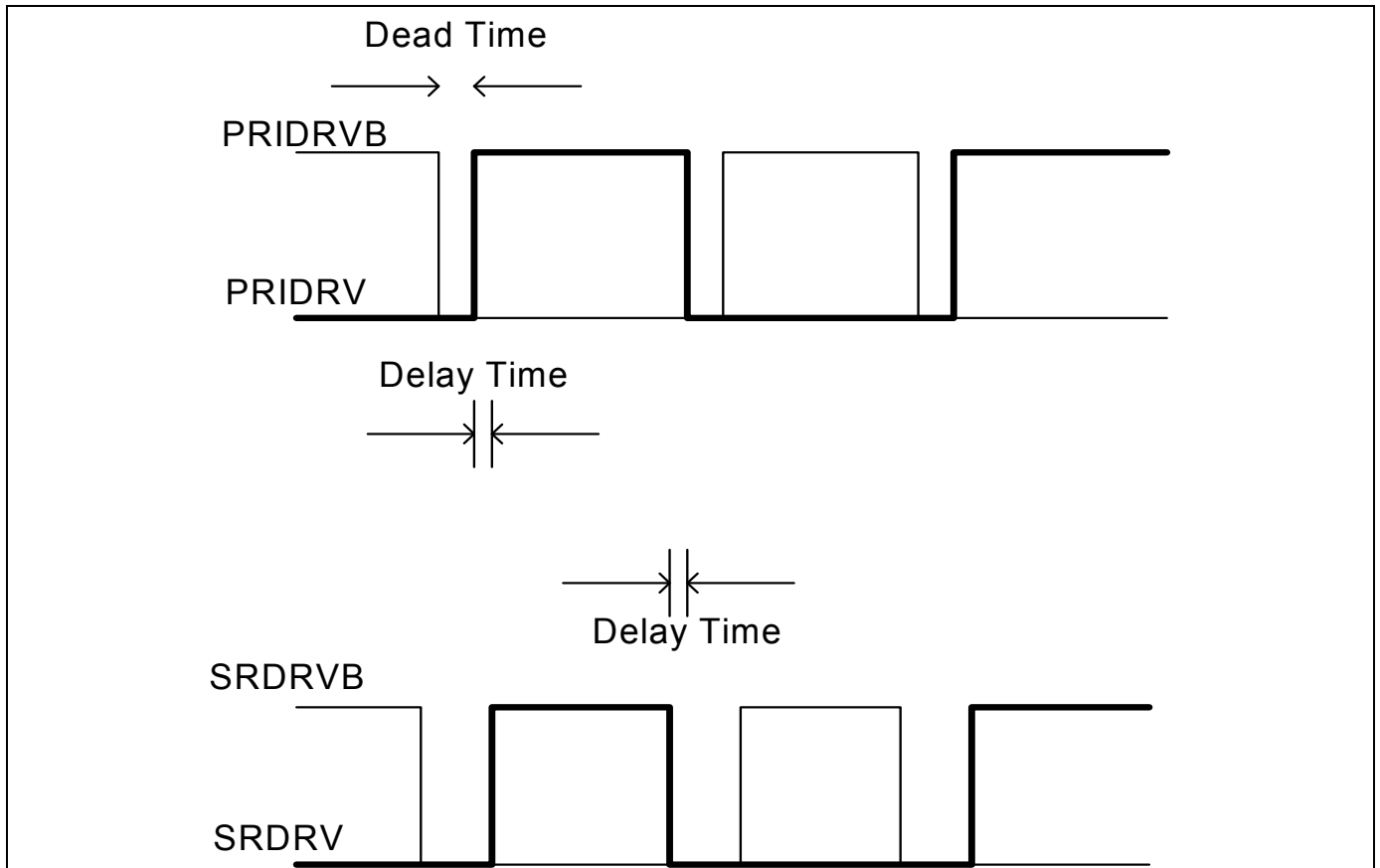

Oscillator

The oscillator frequency is determined by the values of RT and CT.

$$f_{osc} = 1 / (t_{RAMP} + t_{DEADTIME})$$

$$t_{RAMP} = RT * CT * \ln((V_{REF} + I_{CHG} * RT - 1.25) / (V_{REF} + I_{CHG} * RT - 3)) \text{ where } I_{CHG} = 4 * (FEAO - V_{BE}) / R_{SET}$$

$$t_{DEADTIME} = 2.5V / 2.5mA * CT = 850 * CT$$

Resonant Section

FM Modulator

Frequency modulation of the resonant controller section is accomplished by controlling the charging current of the oscillator through resonant error amplifier. The frequency of the resonant section is $\frac{1}{2}$ of the oscillator frequency. Compensation is accomplished by connecting R and C in series to the FEAO pin.

$$I_{CHG} = 4 * (FEAO - V_{BE}) / R_{SET}$$

$$I_{CHG(max)} = 20V / R_{SET}$$

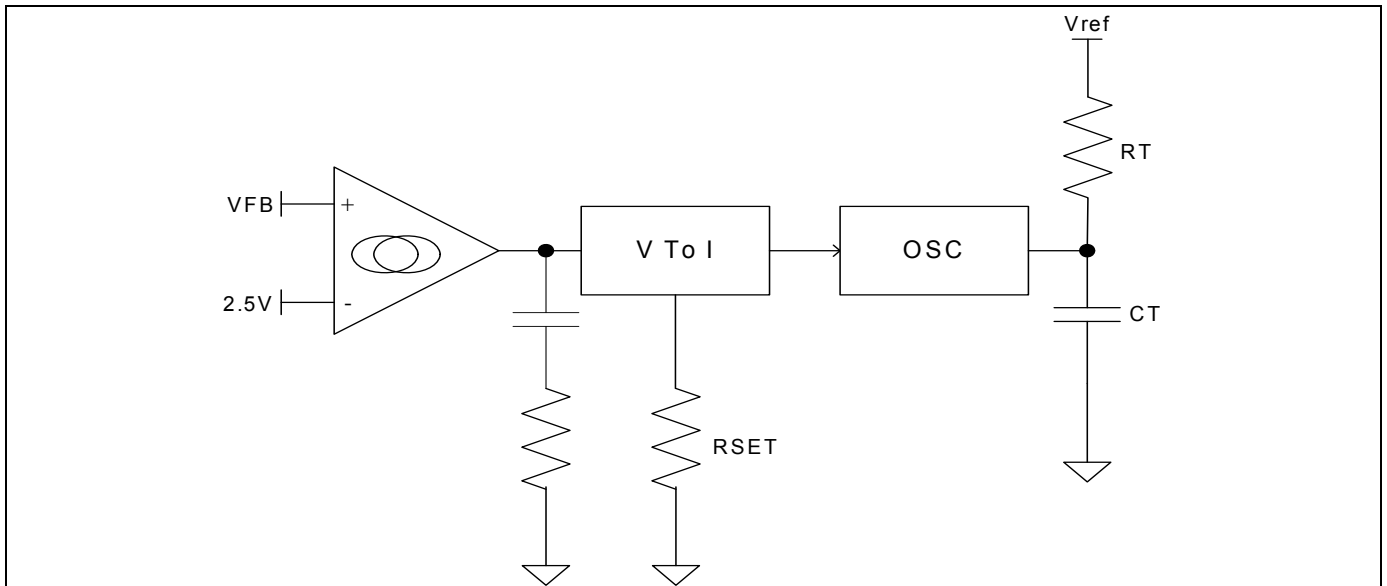

2 PWMings:

SR Ideal Diode PWMing (Synchronous Outputs)

SR Ideal Diode PWMing for synchronous drivers is accomplished by comparing the voltage signal at the RSET pin to RTCT ramp. The pulse-width reduction happens when the voltage at the RSET is lower than 1.5V. This allows safe operation of the power converter with synchronous rectification when the switching frequency is below the highest resonant point frequency f_{r1} .

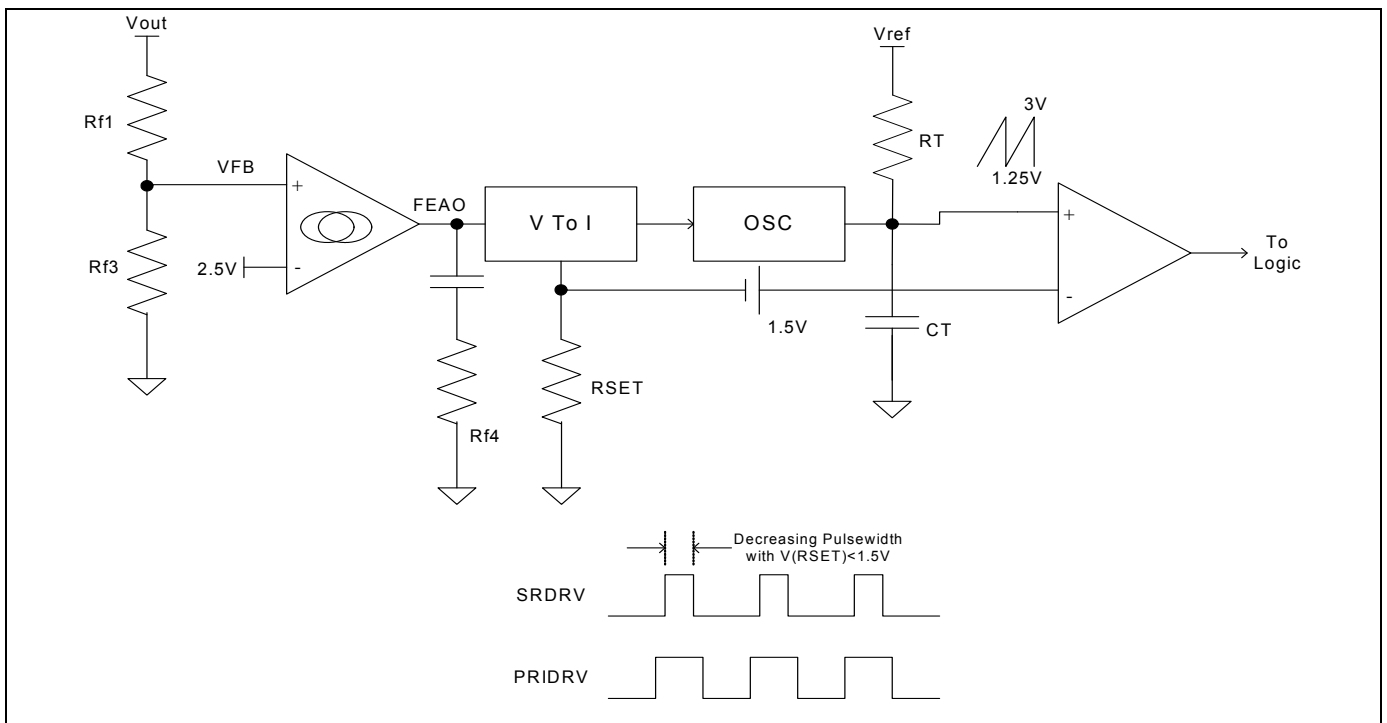

Light Load PWMING

Light Load PWMING control is used in voltage mode. In Application 1, when FEAO is equal to the external reference voltage at D_IN+ due to light load, the frequency of the oscillator is fixed at a value determined by the voltage at FEAO, and the controller enters into PWM mode. In this mode, both frequency modulator and pulse width modulator are active.

In Application 2, the offset voltage V_{os} is externally generated between the V_{FB} pin and D_IN- through a resistor network R_{f1} , R_{f2} and R_{f3} in order to separate the interaction between FM mode and PWM mode.

$$V_{os} = 2.5VXR_{f2}/R_{f3}$$

When the output load is reduced to a point where FEAO is railed to its maximum value of $5V + V_{BE}$, the frequency is fixed at a value determined by $5V + V_{BE}$. Further reduction in load will cause the controller to go into PWM mode when the voltage at the VFB pin is $2.5V + V_{os}$. During this light load operation, FM error amplifier is in open-loop mode while PWM is in closed-loop mode. Compensation is accomplished by connecting R and C in series to the DEAO pin.

In Application 3, low gain configuration accomplished by connecting R_{f4} and R_{f5} in the closed loop configuration. The gain for the PWM is determined by R_{f4} and R_{f5} where the gain is equal to $-R_{f5}/R_{f4}$. The voltage of VR_{set} at which the controller goes into FM and PWM simultaneously is equal to :

$$VR_{set} = D_IN+ \times (1 + R_{f4}/R_{f5}) - (R_{f4}/R_{f5}) \times 3 \text{ where 3 is the peak voltage of RTCT}$$

Varyin R_{set} from VR_{set} to $VR_{set} + 1.75 \times R_{f4}/R_{f5}$ will cause the duty cycle to vary from 50% to 0% while the frequency will vary propotionally according to $1.75 \times R_{f4}/R_{f5}$ where 1.75 is the peak-to-peak voltage of the RTCT ramp. For proper operation, select R_{f5} value so that the current through R_{f5} $\{((D_IN+) - 1.2)/R_{f5}\}$ should be less than 5uA.

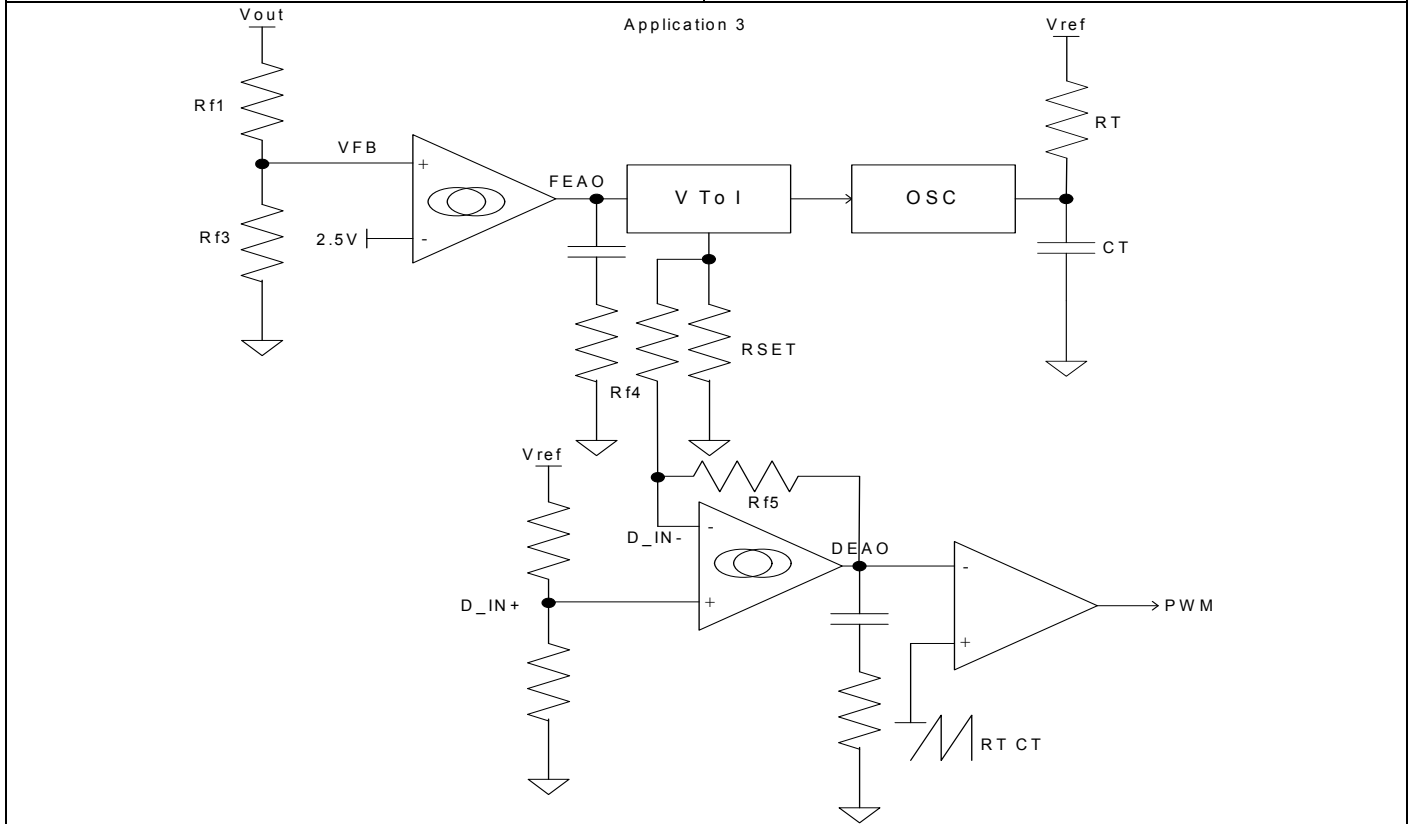
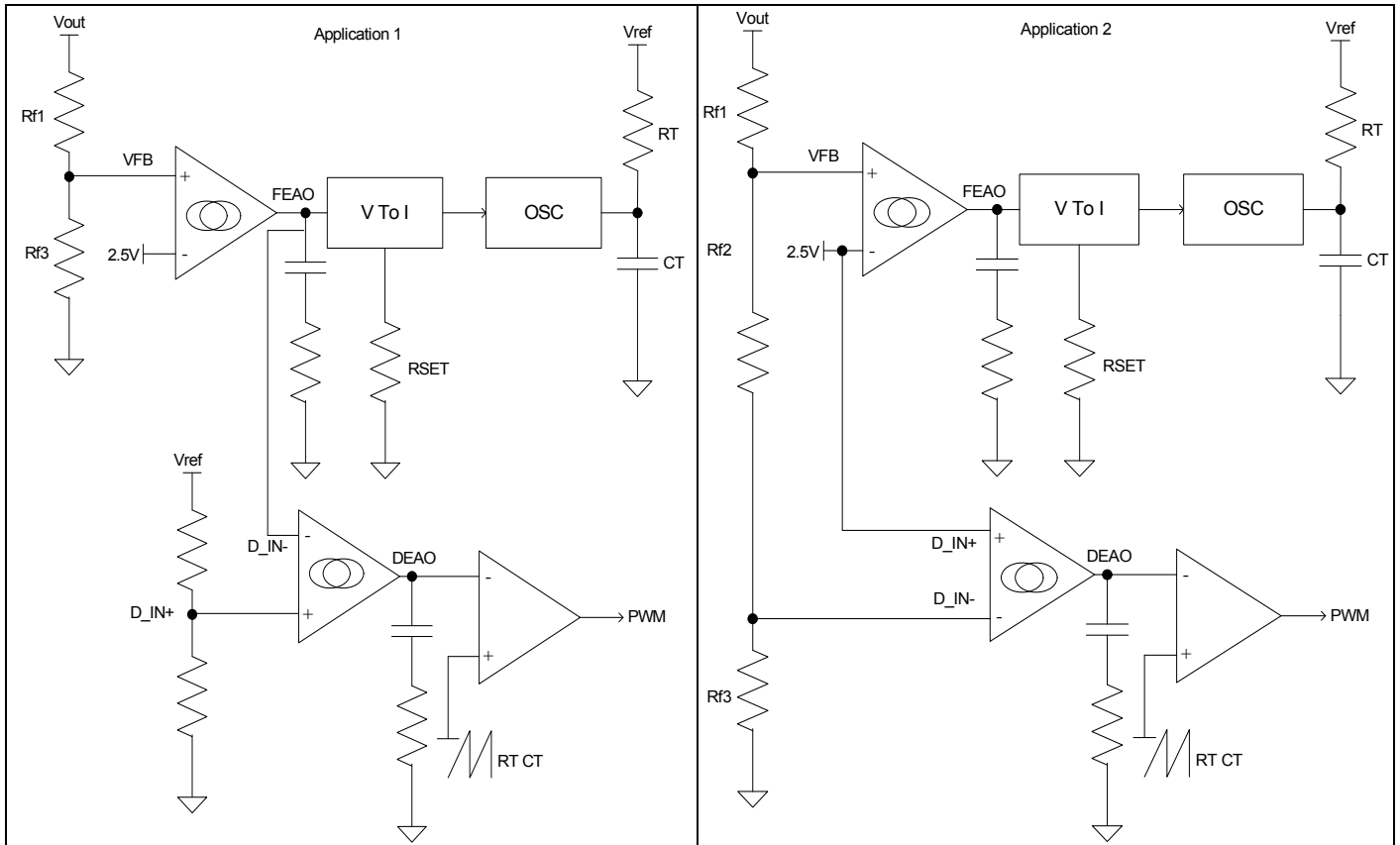

Soft Start and Enable

Soft start of the FM and PWM is controlled by the selection of the external capacitor at CSS pin. A current source of 7.5uA supplies the charging current for the capacitor. Soft start of the FM and PWM begins at 1.25V. The soft start pin CSS also serves as an enable function. The output drivers are enabled when CSS pin reached 1V.

Auto-retry Mode

During normal operation, CSS pin will be charged to $5.5V + V_{BE}$. When VFB exceeds 2.93V due to ILIM exceeds 1V due to over current condition, output drivers are immediate set to low, and CSS begins to discharge with 0.75uA current source. When CSS pin is below 0.9V, 7.5uA current source start charging the CSS pin. When CSS pin reaches 1V, the output drivers are re-enable and the controller goes into soft start mode. If over current condition still exists then, the outputs are immediately disabled, but CSS continues to charge toward 5V. When CSS reaches 5V, 7.5uA charging current is disabled and 0.75uA current source begins to discharge the CSS, and the cycle repeat until over current condition is removed.

OCP Setting

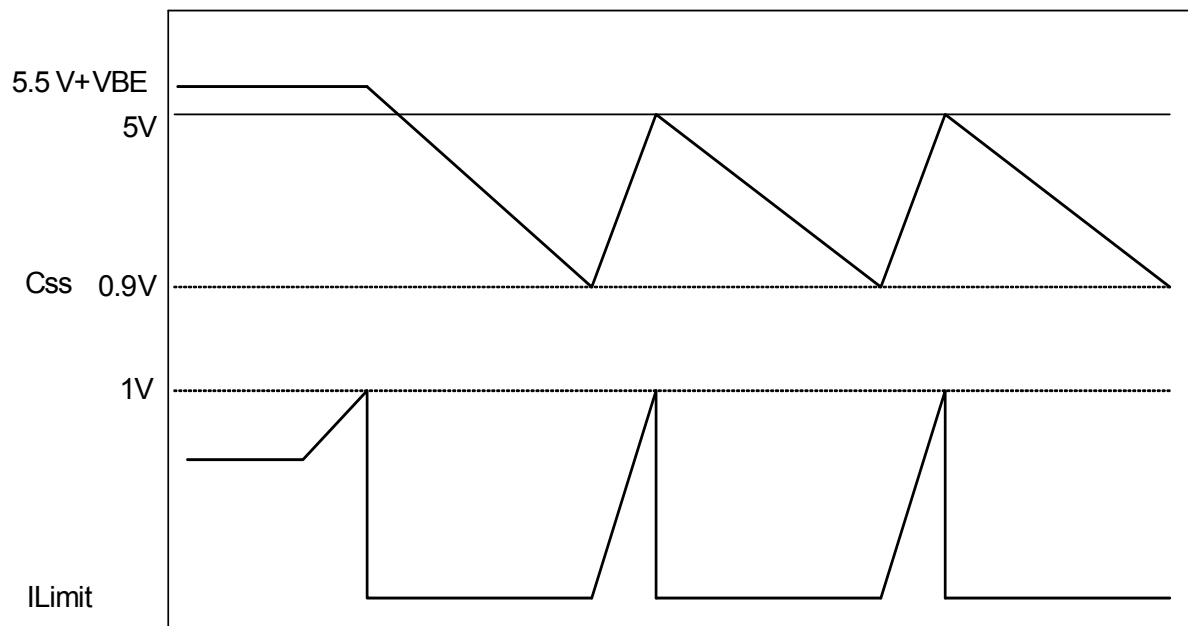

TYPICAL APPLICATION CIRCUIT

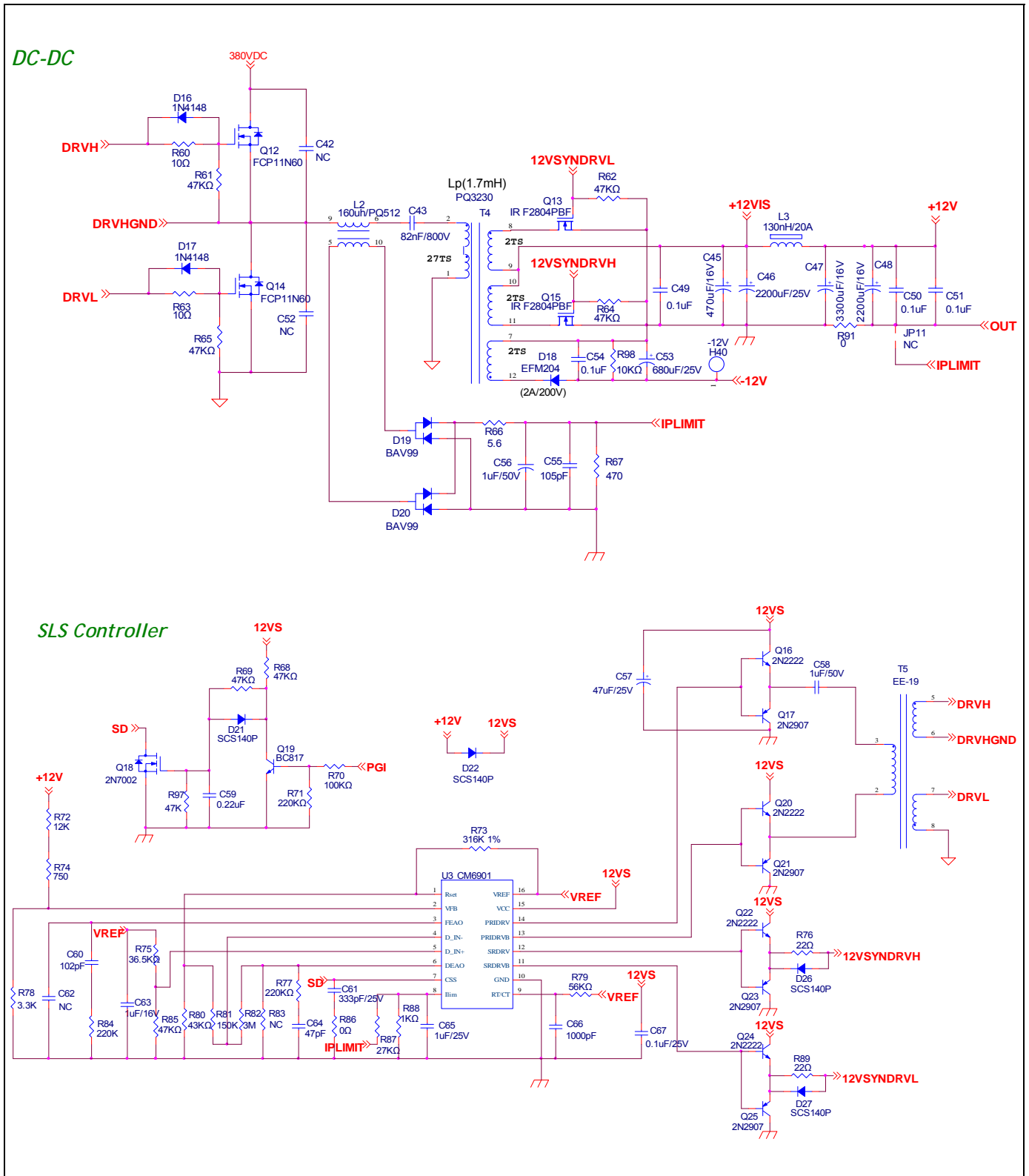

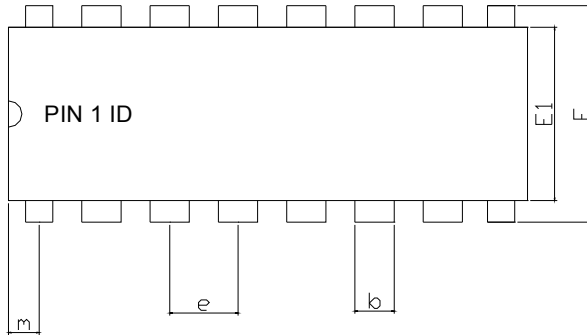
PACKAGE DIMENSION
16-PIN PDIP (P16)

SYMBOLS	DIMENSIONS IN MILLIMETERS			DIMENSIONS IN INCHS		
	MIN	NOM	MAX	MIN	NOM	MAX
A	---	---	4.32	---	---	0.170
A1	0.38	---	---	0.015	---	---
b	1.40	---	1.65	0.055	---	0.065
b1	0.40	---	0.66	0.016	---	0.022
C	0.20	---	0.31	0.008	---	0.012
D	18.79	---	19.31	0.740	---	0.760
E	7.49	---	8.26	0.295	---	0.325
E1	6.09	---	6.61	0.240	---	0.260
e	---	2.54	---	---	0.100	---
L	3.18	---	---	0.125	---	---
m	0.50	---	---	0.02	---	---
θ	0°	---	15°	0°	---	15°

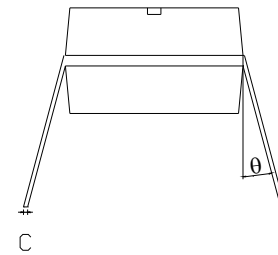
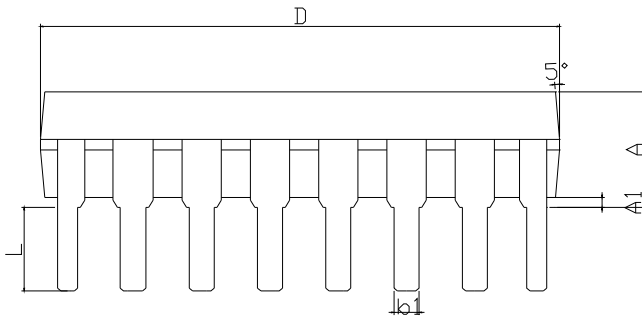
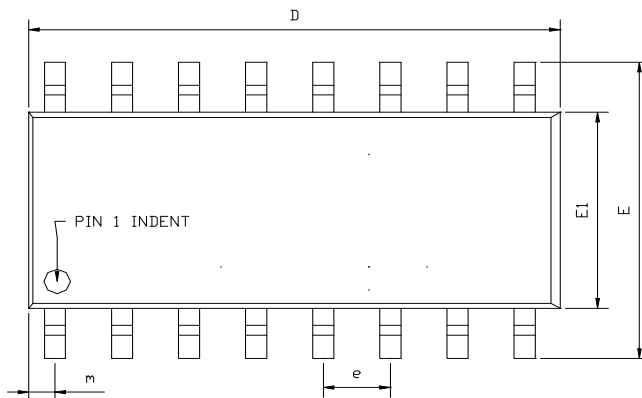
16-PIN SOP (S16)

SYMBOLS	DIMENSIONS IN MILLIMETERS			DIMENSIONS IN INCHS		
	MIN	NOM	MAX	MIN	NOM	MAX
A1	0.05	---	0.15	0.002	---	0.006
A2	1.40	---	1.55	0.055	---	0.061
b	0.30	---	0.51	0.012	---	0.020
C	0.15	---	0.26	0.006	---	0.010
D	9.80	---	10.06	0.386	---	0.396
E	5.79	---	6.20	0.228	---	0.244
E1	3.76	---	4.01	0.148	---	0.158
e	---	1.27	---	---	0.050	---
L	0.38	---	0.69	0.015	---	0.035
m	0.43	---	0.69	0.017	---	0.027
θ	0°	---	8°	0°	---	8°

EXPOSED PAD DIMENSION : (mm)
PAD SIZE: X=2.3 ; Y=2.8

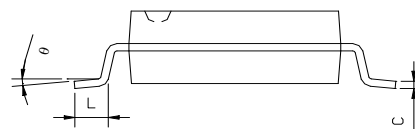
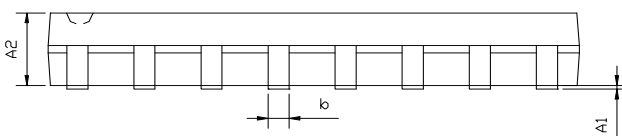

IMPORTANT NOTICE

Champion Microelectronic Corporation (CMC) reserves the right to make changes to its products or to discontinue any integrated circuit product or service without notice, and advises its customers to obtain the latest version of relevant information to verify, before placing orders, that the information being relied on is current.

A few applications using integrated circuit products may involve potential risks of death, personal injury, or severe property or environmental damage. CMC integrated circuit products are not designed, intended, authorized, or warranted to be suitable for use in life-support applications, devices or systems or other critical applications. Use of CMC products in such applications is understood to be fully at the risk of the customer. In order to minimize risks associated with the customer's applications, the customer should provide adequate design and operating safeguards.

CMC assumes no liability to customer product design or application support. CMC warrants the performance of its products to the specifications applicable at the time of sale.

HsinChu Headquarter

5F, No. 11, Park Avenue II,
Science-Based Industrial Park,
HsinChu City, Taiwan
TEL: +886-3-5679979
FAX: +886-3-5679909

Sales & Marketing

21F., No. 96, Sec. 1, Sintai 5th Rd., Sijhih City,
Taipei County 22102,
Taiwan, R.O.C.
TEL: +886-2-2696 3558
FAX: +886-2-2696 3559
