



LC3300

Max. 3MHz, Variable Frequency Step-up DC/DC Converter

DESCRIPTION

The LC3300 variable frequency step-up Converter drives white LEDs with a constant current to provide backlight in cell phones, PDAs, and other hand-held devices. It features allowing series connection of the white LEDs so that the LED currents are identical for uniform brightness. An enable input can be pulsed repeatedly to adjust LEDs brightness. The fast 3MHz operation frequency allows for smaller capacitor and inductor. Fault condition protection uses cycle-by cycle current limiting to sense maximum inductor current and over-voltage protection. The 0.2V low reference voltage minimized the power loss across the current sense resistor.

The converter can operate from 2V to 6V, and capable of delivering maximum 200mA output current at 4-LEDs application with 3V input voltage. Quiescent current drawn from power source is as low as 120uA. All of these features make LC3300 be suitable for the portable devices, which are supplied by a single battery.

LC3300 is available in SOT23-6 package that is PB free.

FEATURES

- Up to 24V Output Voltage
- Wide Operation Range: 2V to 6V
- Maximum 3MHz Operating Frequency
- PWM Dimming Control
- Shutdown Current <1uA
- Current Limit Cycle-by-Cycle
- Low Current Sense Threshold: 200mV
- 24V Over Output Voltage Protection
- Compact SOT23-6 Package

APPLICATIONS

- Compact Back Light Module
- Power Source for LED
- Constant Current Source

TYPICAL APPLICATION

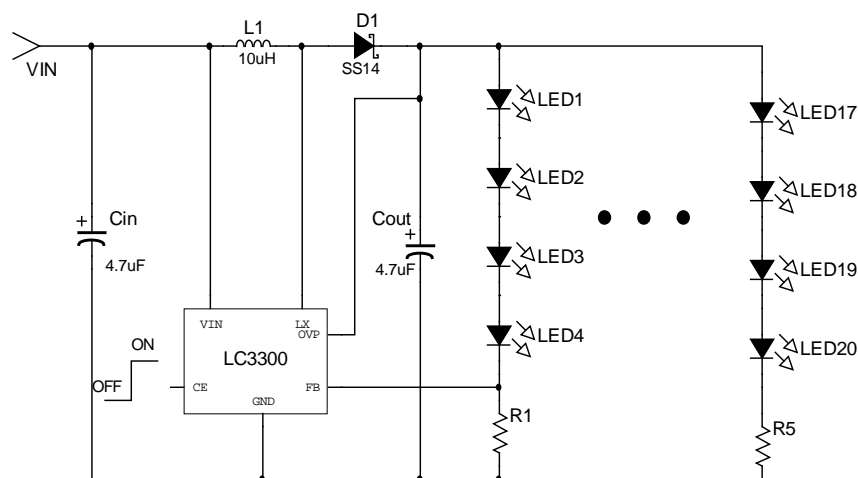

Figure1. LC3300 Typical Application Circuit

ORDERING INFORMATION

LC2316 [1](#) [2](#) [3](#)

Code	Description
1	Temperature & RoHS: C: -40~85°C, Pb Free RoHS Std.
2	Package Type: B6: SOT-23-6
3	Packing Type: TR: Tape & Reel (Standard)

MARKING INFORMATION

Product Classification		LC3300CB6TR
Marking		
LEBZZ	LE: Product Code	
	B: FAB Code	
		ZZ: Date Code

PIN DESCRIPTION

Pin No.	Symbol	Description
1	LX	Switching node
2	GND	Ground
3	FB	Pin for Feedback Voltage
4	CE	Chip Enable Pin (Active with "H"), connect to VIN if not used.
5	OVP	Over Voltage Protection
6	VIN	Power Supply

BLOCK DIAGRAM

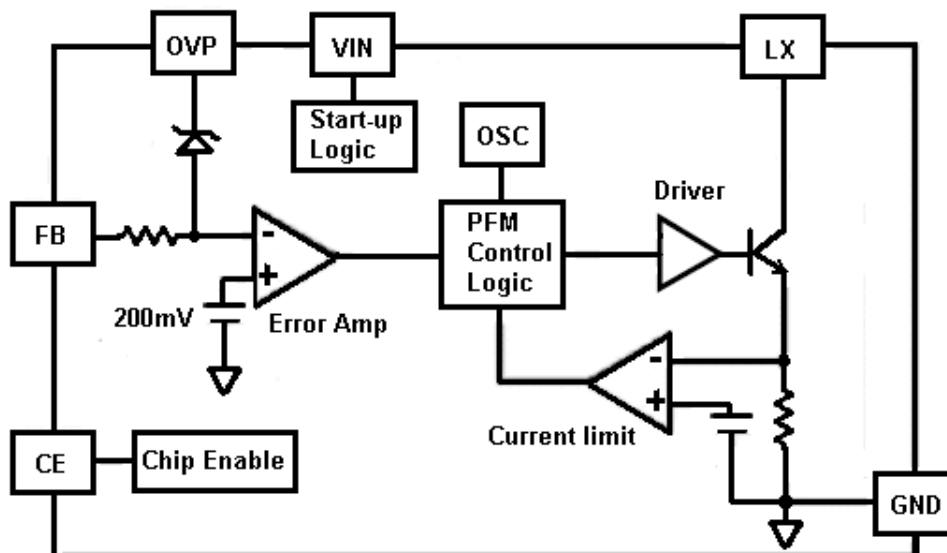

ABSOLUTE MAXIMUM RATING

Parameter	Value
Max Input Voltage	-0.3V to 8V
CE Pin Voltage	-0.3V to (Vin+0.3V)
LX Pin Output Current	1.6A
LX Pin Voltage	24V
Operating Junction Temperature (T _J)	125°C
Ambient Temperature (T _A)	-40°C to 85°C
Power Dissipation SOT-23-6	250mW
Storage Temperature (T _S)	-40°C to 150°C
Lead Temperature & Time	260°C, 10Sec

ELECTRICAL CHARACTERISTICS

(T_a=25°C, V_{IN}=3V, V_{CE}=3V, unless otherwise noted)

Symbol	Item	Conditions	Min.	Typ.	Max.	Unit
V _{IN}	Operating Input Voltage		2		6	V
V _{FB}	Feedback Voltage		0.190	0.200	0.210	V
I _{FB}	FB Pin Bias Current		10	45	100	nA
I _Q	Quiescent Current	V _{FB} =0.3V		93	120	uA
		V _{CE} =0V		0.4	1.0	uA
F _{MAX}	Maximum switching Frequency	V _{FB} =0V, Floating OVP Pin		3		MHz
I _{LIMIT}	Switching Current Limit			1.6		A
V _{CESAT}	Switching Saturation Voltage	I _{LX} =300mA		260		mV
I _{LX}	Switching pin Leak Current	V _{LX} =5V		0.11		uA
V _{CEH}	CE Voltage High	V _{CE} =0 to 3V	1.5			V
V _{CEL}	CE Voltage Low	V _{CE} =3 to 0V			0.4	V
I _{CE}	CE Pin Bias Current	V _{IN} =V _{CE} =3V		18		uA
V _{OVP}	Over Voltage Protection			24		V

TYPICAL PERFORMANCE CHARACTERISTICS

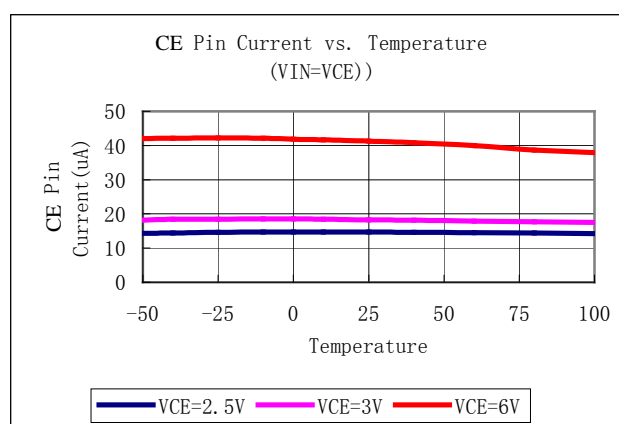
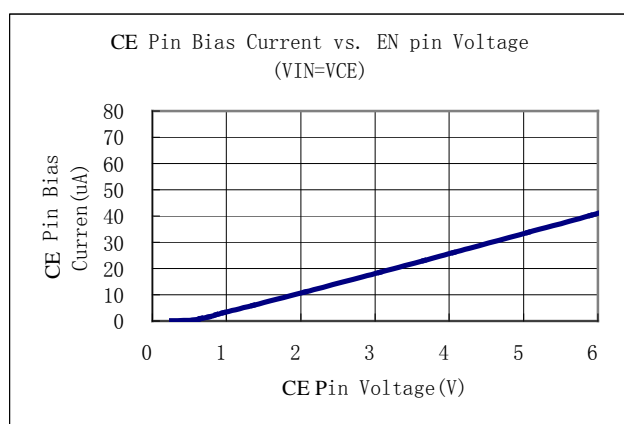

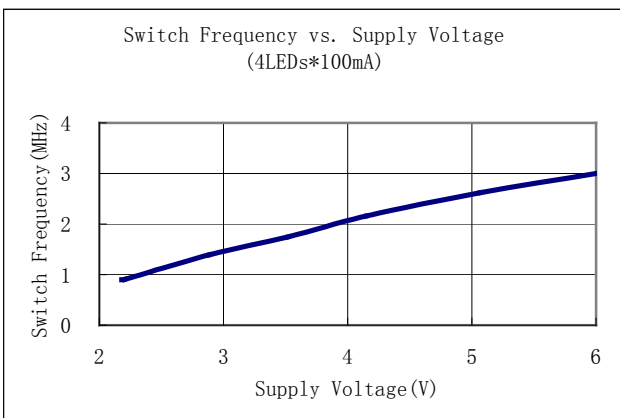
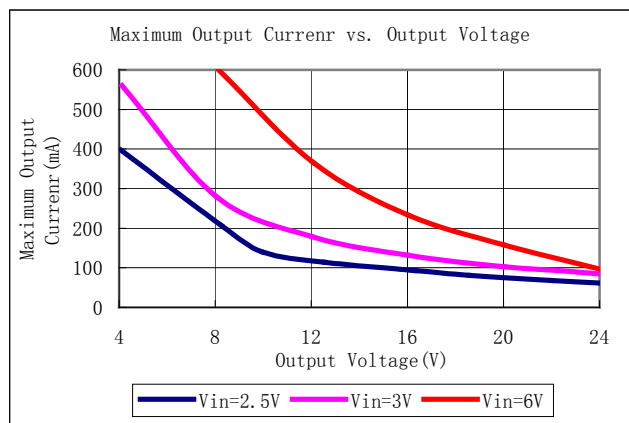
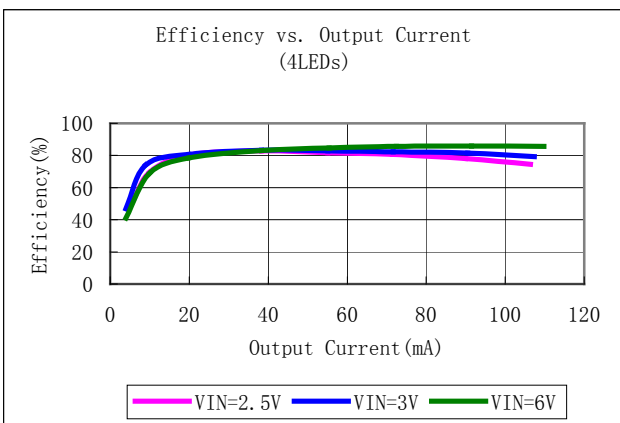
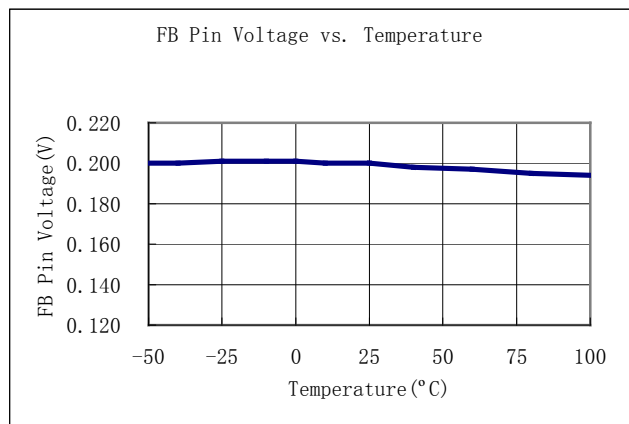
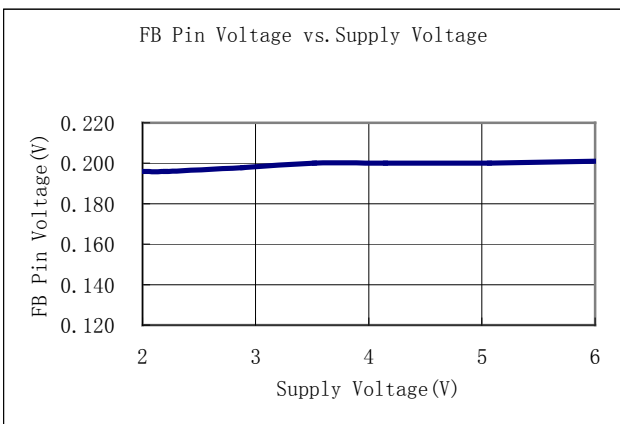
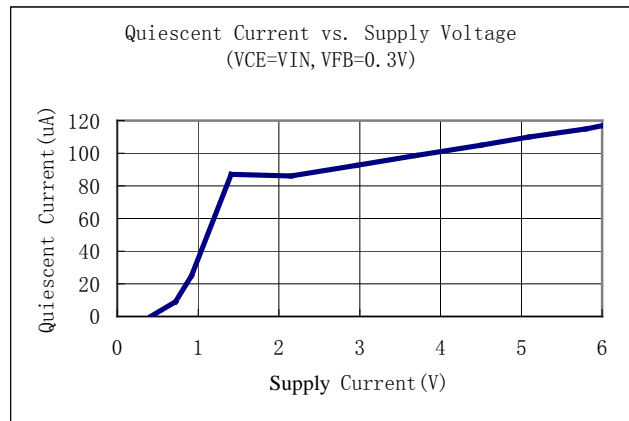
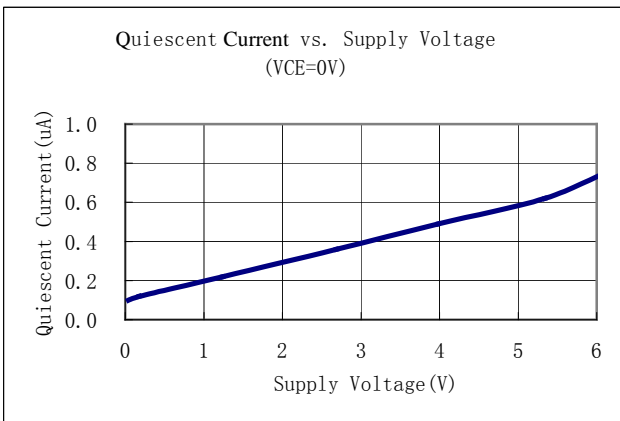

APPLICATION INFORMATION

Dimming Control

1. Using a PWM Signal to CE Pin

When adding the PWM signal to CE pin, the LC3300 is turned on or off by the PWM signal, so the LEDs operate at either zero or full current. The average LED current increase proportionally with the duty cycle of the PWM signal.

2. Using a DC Voltage to FB Pin

From the Figure 2, we can add a DC voltage to FB pin, we adjust the LED current by Changing the DC voltage, which control the brightness, DC voltage range is from 0V to 2V.

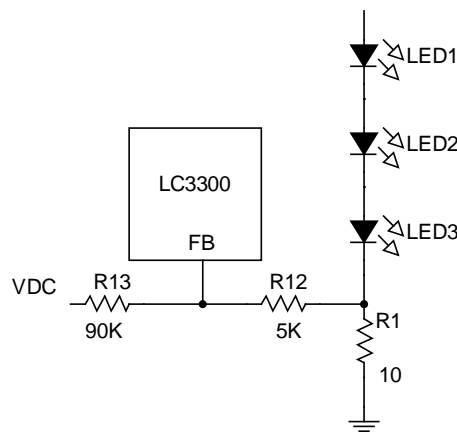

Figure 2. Dimming Control Using a DC Voltage

3. Using a Filtered PWM Signal to FB Pin

The filtered PWM signal can be considered as an adjustable DC voltage. It can be used to replace the variable DC voltage source in dimming control. The circuit is shown in Figure 3.

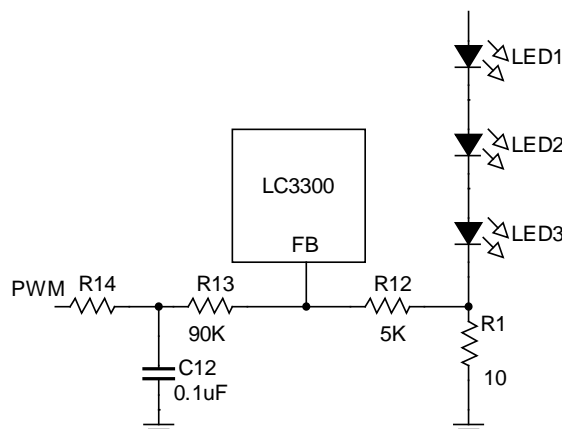

Figure 3. Dimming Control Using a Filtered PWM Signal

PACKAGE INFORMATION

