



**Description**

The SE809 is a cost-effective system supervisor Integrated Circuit (IC) designed to monitor  $V_{CC}$  in digital and mixed signal systems and provide a warning signal when the system power supply is out of working range, and a reset signal to the host processor when necessary. No external components are required.

The reset output is driven active within 20 $\mu$ sec of  $V_{CC}$  falling through the reset voltage threshold. Reset is maintained active after  $V_{CC}$  rises above the reset threshold. The SE809 has an active-low  $\overline{\text{RESET}}$  output. The output of the SE809 is guaranteed valid down to  $V_{CC}=1V$ .

The SE809 is characterized for operation from -40°C to 85°C, junction temperature. The SE809 is optimized to reject fast transient glitches on the  $V_{CC}$  line. Low supply current of 7 $\mu$ A ( $V_{CC}=3.3V$ ) makes these devices suitable for battery powered applications. The output voltages range from 1.7V to 4.5V in 100mV increments. Standard voltage versions are 2.30, 2.63, 2.93, 3.08, 4.0, 4.38, and

**Features**

- Precision  $V_{CC}$  Monitor for 2.8V, 3.0V, 3.3V, and 5.0V Supplies
- 150mSec typical  $\overline{\text{RESET}}$  Output Delay.
- $\overline{\text{RESET}}$  Output Guaranteed to  $V_{CC}=1.0V$
- Low 7 $\mu$ A Supply Current typical.
- $V_{CC}$  Transient Immunity
- Small SOT-23 Package and TO-92 Package
- No External Components
- ESD rating is 7KV(HBM).
- Wide Operating Temperature: -40°C to 85°C
- 100% Lead (Pb)-Free

**Application**

- Computers
- Embedded systems
- Battery powered equipment
- Critical  $\mu$ P power supply monitoring

**Pin Configuration**

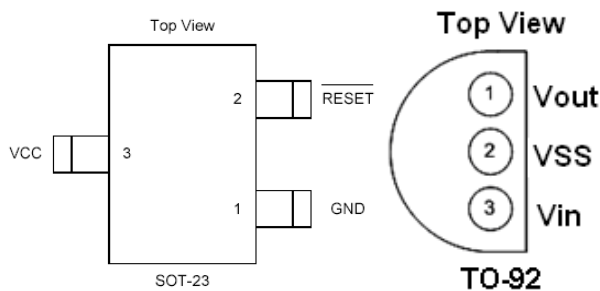

**Application Diagram**

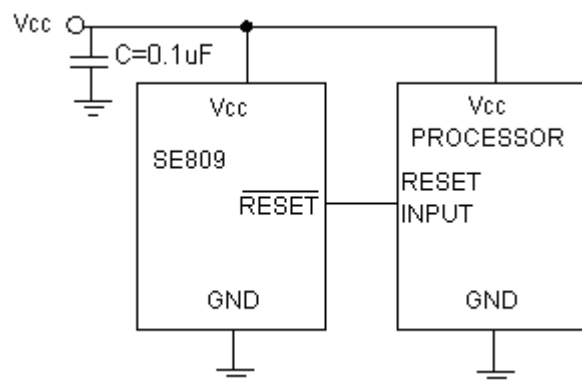



**Ordering/Marking Information (SOT23)**

Ordering Information	Marking Information	The "x" denotes a suffix for V <sub>CC</sub> threshold. The last character is the batch number. A dot on top right corner is for lead-free process.
SE809xS	S809xa*	
<b>Suffix</b>	<b>Reset V<sub>CC</sub> threshold(V)</b>	
L	4.63	
M	4.38	
J	4.00	
T	3.08	
S	2.93	
R	2.63	

**Ordering/Marking Information (TO92)**

Ordering Information	Marking Information	XXXX is the batch number. Lead-free package is indicated by LF after XXXX.
SE809Z	SE809Z XXXX-LF	
<b>Suffix</b>	<b>Reset V<sub>CC</sub> threshold(V)</b>	
Z	2.30	

**Absolute Maximum Ratings<sup>(1)</sup>**

Parameter	Symbol	Value	Units
Input Voltage	V <sub>CC</sub>	5.5	V
Output Voltage	RESET	-0.3 to (V <sub>CC</sub> + 0.3)	V
Input Current		20	mA
Output Current	I <sub>OUT</sub>	20	mA
Power Dissipation	P <sub>D</sub>	Internally Limited <sup>(3)</sup>	
Output Short Circuit Duration		Infinite	
Thermal Resistance, Junction-to-Ambient	Θ <sub>JA</sub>	230	°C/W
Operating Temperature Range	T <sub>A</sub>	-40~ 85	°C
Lead Temperature (Soldering, 10 sec.)		260	°C
Junction Temperature	T <sub>J</sub>	0 to +125	°C
Storage Temperature	T <sub>S</sub>	-60 to +150	°C

**Operating Rating<sup>(2)</sup>**

Parameter	Symbol	Value	Units
Supply Input Voltage	V <sub>CC</sub>	+2.0V to +5.5	V
Junction Temperature	T <sub>J</sub>	0 to +125	°C



**Electrical Characteristics**

V<sub>CC</sub>=5V for L/M/J ;3.3V for T/S ;3.0V for R ,T<sub>A</sub> = 25°C, unless otherwise specified.

Symbol	Parameter	Condition	Min	Typ	Max	Unit
V <sub>CC</sub>	Input Voltage		2.0		5.5	V
I <sub>CC</sub>	Supply Current		--	7	10	μA
V <sub>TH</sub>	Reset Threshold	SE809L-4.63V	4.51	4.63	4.75	V
		SE809M-4.38V	4.27	4.38	4.49	
		SE809J-4.00V	3.90	4.00	4.10	
		SE809T-3.08V	3.00	3.08	3.16	
		SE809S-2.93V	2.85	2.93	3.00	
		SE809R-2.63V	2.56	2.63	2.70	
		SE809R-2.30V	2.18	2.25	2.33	
	Reset Threshold Temperature Coefficient <sup>(4)</sup>		--	30	--	ppm/°C
	V <sub>CC</sub> to Reset Delay V <sub>CC</sub> = V <sub>TH</sub> to (V <sub>TH</sub> – 100mV)		--	20	--	μsec
	Reset Active Timeout Period		--	150		msec
V <sub>OL</sub>	RESET Output Voltage Low	I <sub>SINK</sub> = 3mA	--	--	0.4	V
V <sub>OH</sub>	RESET Output Voltage High	I <sub>SOURCE</sub> = 800μA	0.8V <sub>CC</sub>	--	--	V

**PIN DESCRIPTION:**

Pin No.	Symbol	Description
1	GND	Ground
2	RESET	RESET output remains low while V <sub>CC</sub> is below the reset voltage threshold and for 150msec(typ) after V <sub>CC</sub> rises above reset threshold
3	V <sub>CC</sub>	Supply Voltage (typ.)

**Note 1:** Exceeding the absolute maximum rating may damage the device.

**Note 2:** The device is not guaranteed to function outside its operating rating.

**Note 3:** The maximum allowable power dissipation at any T<sub>A</sub> (ambient temperature) is calculated using: P<sub>D(MAX)</sub> = (T<sub>J(MAX)</sub> – T<sub>A</sub>)/θ<sub>JA</sub>. Exceeding the maximum allowable power dissipation will result in excessive die temperature, and the regulator will go into thermal shutdown. See “Thermal Consideration” section for details

**Note 4:** RESET threshold temperature coefficient is the worst case voltage change divided by the total temperature range.



Typical Performance Characteristics

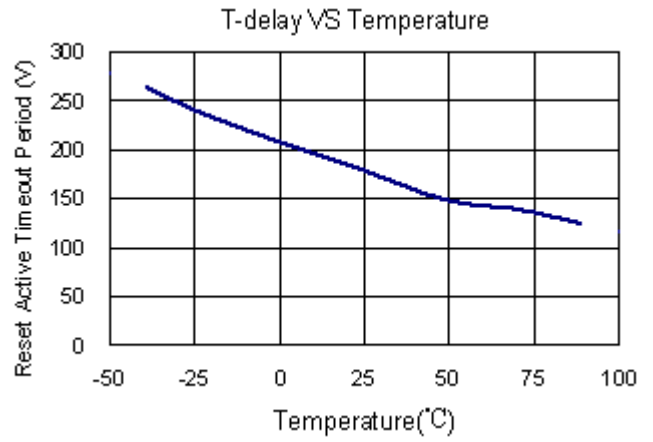
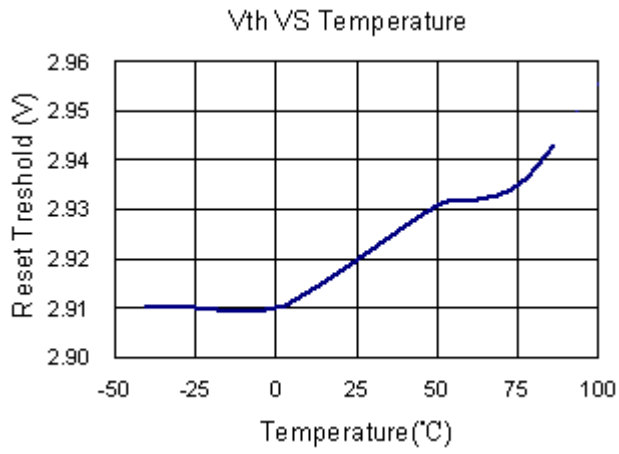



**OUTLINE DRAWING SOT-23**

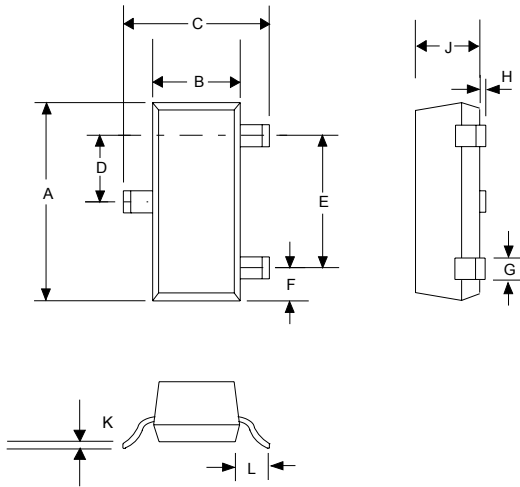

DIMENSIONS				
DIM <sup>N</sup>	INCHES		MM	
	MIN	MAX	MIN	MAX
A	0.110	0.120	2.80	3.04
B	0.047	0.055	1.20	1.40
C	0.083	0.104	2.10	2.64
D	0.035	0.040	0.89	1.03
E	0.070	0.080	1.78	2.05
F	0.018	0.024	0.45	0.60
G	0.015	0.020	0.37	0.51
H	0.0005	0.004	0.013	0.10
J	0.034	0.040	0.887	1.02
K	0.003	0.007	0.085	0.18
L	-	0.027	-	0.69

**OUTLINE DRAWING TO-92**

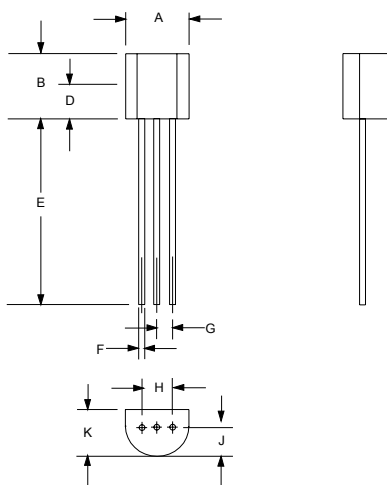

DIMENSIONS				
DIM <sup>N</sup>	INCHES		MM	
	MIN	MAX	MIN	MAX
A	0.175	0.205	4.445	5.207
B	0.170	0.210	4.318	5.334
E	0.500	0.610	12.70	15.50
F	0.016	0.021	0.407	0.533
G	0.045	0.055	1.143	1.397
H	0.095	0.105	2.413	2.667
J	0.080	0.105	2.032	2.667
K	0.125	0.165	3.175	4.191



### **Contact Information**

Seaward Electronics Incorporated – China

Section B, 2nd Floor, ShangDi Scientific Office Complex, #22 Shangdi Xinxu Rd

Haidian District, Beijing 100085, China

Tel: 86-10-8289-5700/01/05

Fax: 86-10-8289-5706

Email: [sales@seawardinc.com.cn](mailto:sales@seawardinc.com.cn)

Seaward Electronics Corporation – Taiwan

2F, #181, Sec. 3, Minguan East Rd,

Taipei, Taiwan R.O.C

Tel: 886-2-2712-0307

Fax: 886-2-2712-0191

Email: [sales@seawardinc.com.tw](mailto:sales@seawardinc.com.tw)

Seaward Electronics Incorporated – North America

1512 Centre Pointe Dr.

Milpitas, CA95035, USA

Tel: 1-408-821-6600

Last Updated - 9/4/2008