

Dimming Universal High Brightness LED Driver

Features

- Input voltage range from 5V to 450V
- Cascode topology for lower switching loss and surge voltage
- Constant off time control
- Line compensation of output current
- Enable pin
- Switch/PWM/Linear dimming function
- Leading-edge blanking
- Frequency modulation in short circuit protection and low output voltage condition
- Over-temperature protection
- Over-current protection
- SOP-8 package, with few external components needed

Application

- DC/DC or AC/DC LED driver application
- LED T Bar lighting
- Cabin light in car
- Both non-isolation and isolation lighting in high input voltage

General Description

The GR8210 is a high brightness LED driver with the cascode topology that patented by Greenergy. A high voltage power NMOSFET, BV_{DSS} is 600V, as the high side device and the power NMOSFET inside the GR8210 as the low side device in this cascode topology. A Zener voltage, was generated by ST pin of the GR8210, turn on the high side device all the time by connected to the gate terminal of the high side device. The source terminal and the drain terminal of the high side device are connected to the DRN pin of the GR8210 and the input voltage rail respectively to absorb the very large voltage potential. The current peak value was decided by the sensing resistor in the CS pin, the low side device was turned off by the current peak detection then delay a fixed off time that set by the resistor in the RT pin of GR8210.

There are PWM and liner dimming in GR8210 to adjust the LED brightness. In the abnormal operation, the inner OTP function could protect the IC damage.

* Refer to Feature List on page 2 for the switching dimming function

Ordering and Marking Information

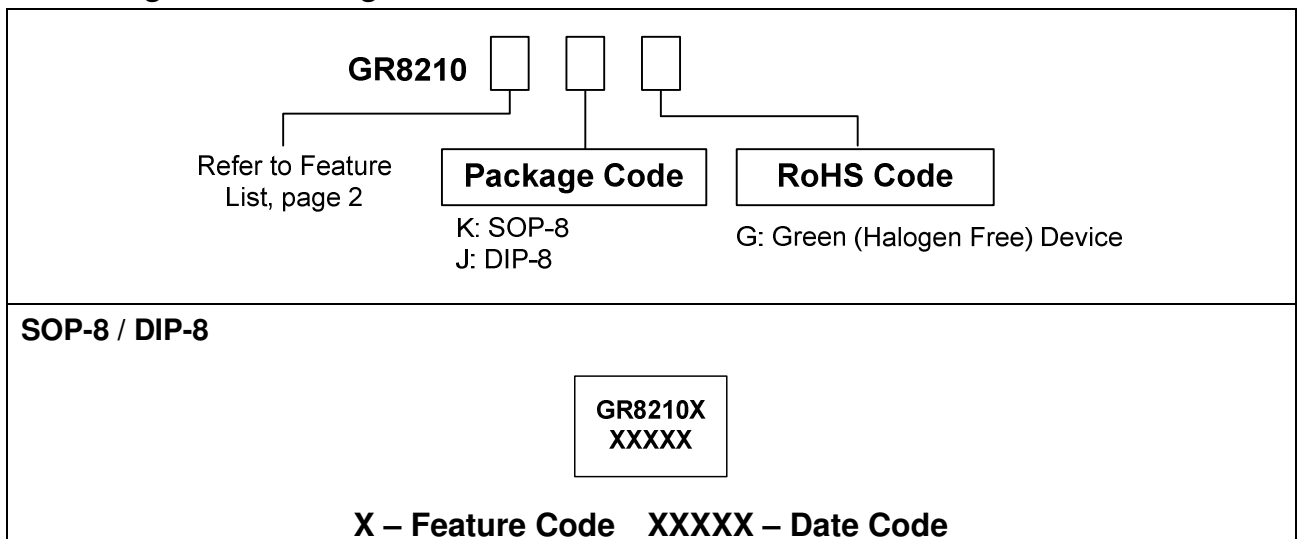

Greenergy OPTO Inc. reserves the right to make changes to improve reliability or manufacture ability without notice, and advise customers to obtain the latest version of relevant information to verify before placing orders.

Feature List

Part Name	Switching Dimming
GR8210N	No
GR8210D	Yes

Pin Configuration

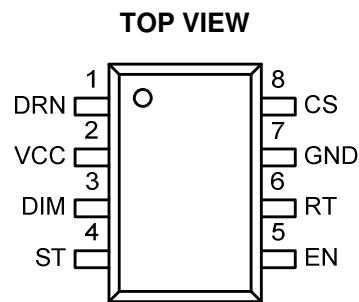

Pin Description

Pin No.	Name	Function
1	DRN	The drain terminal of the internal NMOSFET.
2	VCC	The output of the internal regulator.
3	DIM	The dimming signal input pin.
4	ST	The anode terminal of the internal Zener diode.
5	EN	The enable input terminal.
6	RT	An external resistor located from this pin to GND to generate a reference current to fix the off time in the switching operation.
7	GND	Ground of the circuit.
8	CS	Current sense voltage input terminal, the LED current also flows from this pin to the sense resistor outside.

Absolute Maximum Ratings

Supply voltage, V_{CC}	-----	5.5V
Drain voltage, V_{DRN}	-----	26V
DIM voltage to GND, V_{DIM}	-----	-0.3V ~ 6V
Zener voltage, V_{ST}	-----	18V
EN voltage to GND, V_{EN}	-----	-0.3V ~ 6V
RT voltage to GND, V_{RT}	-----	-0.3V ~ 6V
CS voltage to GND, V_{CS}	-----	-0.3V ~ 6V
Junction temperature	-----	150°C
Operating ambient temperature	-----	-20°C to 85°C
Storage temperature range	-----	-65°C to 150°C
Package thermal resistance (SOP-8), θ_{JA}	-----	160°C/W
Power dissipation (SOP-8, at ambient temperature = 85°C)	-----	400mW
Lead temperature (Soldering, 10sec)	-----	260°C
ESD voltage protection, human body model	-----	3.0KV
ESD voltage protection, machine model	-----	300V

Recommended Operating Conditions

Item	Min.	Max.	Unit
Input voltage, V_{IN}^*	5	450	V
Output current, I_{OUT}^*	0.1	0.8	A

* Refer to the Figure-1.

Block Diagram

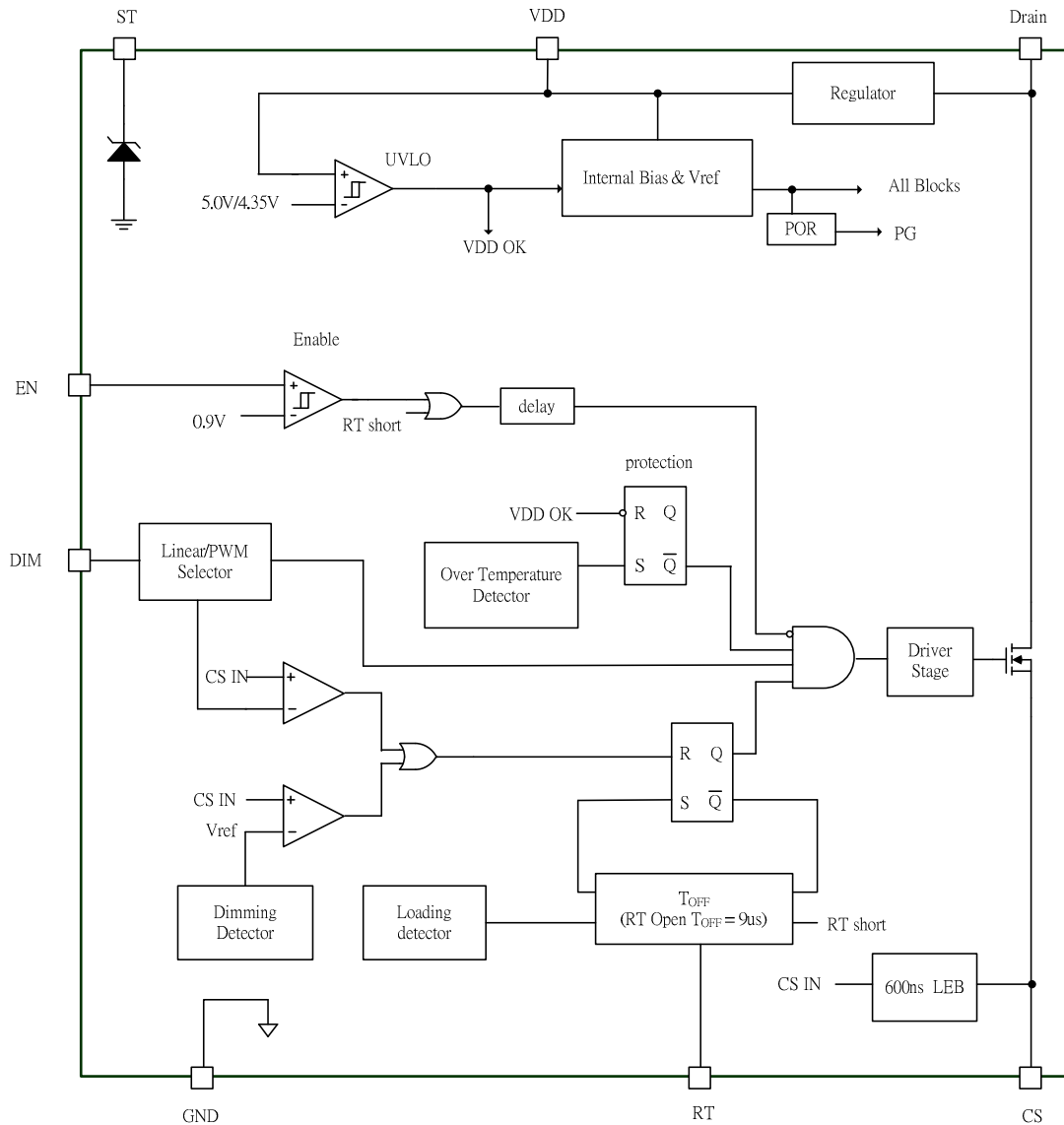

Electrical Characteristics ($V_{CC} = 5V$, $T_A = 25^\circ C$, unless otherwise specified.)

Parameter	Symbol	Test Conditions	Min	Typ	Max	Units
-----------	--------	-----------------	-----	-----	-----	-------

INPUT VOLTAGE

Input voltage range	V_{IN}	With Cascode NMOSFET	5	-	450	V
---------------------	----------	----------------------	---	---	-----	---

VCC SECTION

V_{CC} UVLO	V_{UVLO}		4.8	5.0	5.2	V
V_{CC} UVLO hysteresis	V_{UV_LOHY}			0.65		V
Operation current	I_{Q-OP}	Normal Operation	0.3	0.5	0.9	mA

ST SECTION

Start up voltage in normal operation	V_{ST}	$I_{ST} = 50\mu A$	12	15	18	V
Start up current at 156V	I_{ST}	$V_{IN} = 156V$, $R_{ST} = 2M\Omega$	50	70.5	90	μA

CURRENT SENSE SECTION

Peak current reference voltage	V_{CS1}	$V_{IN} = 312V$, $L = 4.7\mu H$, $R_{LOAD} = 10\Omega$, $R_{CS} = 0.3\Omega$, asynchronous rectifier: xxxx.	240	250	260	mV
Leading edge blanking time	T_{LEB}		500	600	700	ns

INTERNAL POWER NMOSFET SECTION

Turned on resistance	$R_{DS(ON)}$	$V_{CC} = 5V$, $V_{CS} = 0.1V$, $R_{DRN} = 10K\Omega$ from V_{IN} to DRN.	0.3	0.7	1.0	Ω
----------------------	--------------	---	-----	-----	-----	----------

EN SECTION

Enable threshold	V_{EN}		0.85	0.9	0.95	V
Enable function hysteresis	V_{EN_HYS}			0.1		V
Delay cycles of enable pin	T_{EN_D}			32		Cycles

RT SECTION

RT threshold voltage	V_{RT}	$V_{CC} = 5V$, $R_{RT} = 200K\Omega$.	1.14	1.2	1.26	V
Constant off time	T_{OFF}	$V_{CC} = 5V$, $R_{RT} = 200K\Omega$.	20.5	22.5	24.5	μs
Constant off time	$T_{OFF_default}$	$V_{CC} = 5V$, RT to V_{CC} .	9	10	11	μs

DIMMING FUNCTION (LD/PD)

PWM dimming input low voltage threshold	V_{OL}		-	-	0.9	V
PWM dimming input high voltage threshold	V_{OH}		2	-	-	V
Linear dimming voltage threshold of 100% current regulation	V_{L_MAX}	100% Output Current.	0.475	0.5	0.525	V

Electrical Characteristics (Cont.)

Parameter	Symbol	Test Conditions	Min	Typ	Max	Units
-----------	--------	-----------------	-----	-----	-----	-------

OVER TEMPERATURE PROTECTION SECTION

OTP trip level	T_{OTP}			150		°C
OTP hysteresis	T_{OTP_HYS}			25		°C

* Switching dimming is optional.

Application Information

Operation

GR8210 is a cascade topology constant current PWM converter for high brightness LED driving. In the Figure-1, after the V_{IN} ramps up, the V_{ST} also ramps up to the target with a delay time. This voltage turns on the M_1 when its level greater than the V_{TH_M1} , then the V_{CC} was created. M_2 was turned on in the on period of the first cycle. The current flows through LEDs, L_1 , M_1 , M_2 , R_S , and back to C_{IN} finally. In the end of this period, the M_2 might be to turn off when the V_{CS} reached 0.25V. A fixed off time was followed as the off period of the first cycle. During the off period, the current flows through LEDs, L_1 and D_1 . A new cycle will start when the fixed off time finish.

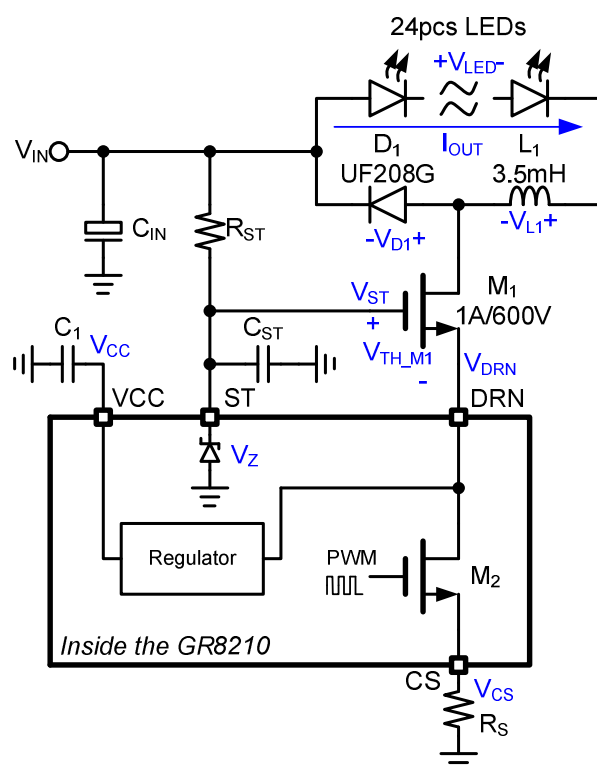

Figure-1 The brief schematic to explain the system operation.

Start Up Function

The waveforms of Figure-2 explain the power on procedure in the GR8210 application circuit. The V_{ST} created slowly due to the large time constant, T_{ST} , that formed by R_{ST} and C_{ST} . The reasonable ranges of R_{ST} and C_{ST} are $1M\Omega$ to $10M\Omega$ and $0.1\mu F$ to $1\mu F$ respectively. A large resistance could limit the dissipated current under hundreds microampere. These two sets of components value affect the T_{ST} in the range of hundreds millisecond to thousands millisecond. The T_{ST} order is available defined by the user. The ceramic type of capacitor is suitable for V_{ST} regulation.

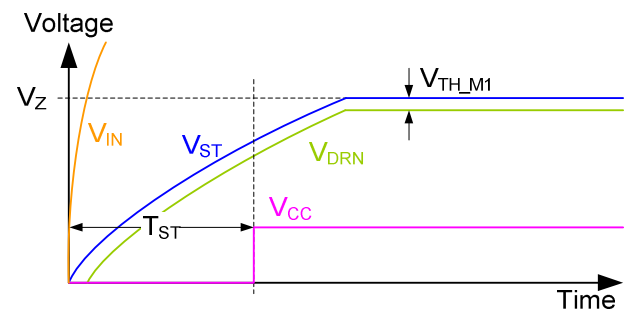

Figure-2 The start up waveforms, the voltage designators assigned in figure-1.

V_{CC} Regulator

An internal regulator in the GR8210 could generate a 5V voltage source to supply the operating current for control circuit. The input voltage of the internal regulator is the V_{DRN} . V_{CC} regulated in the M_2 off period due to the V_{DRN} is approximately zero volt in the M_2 on period. Therefore, a capacitor, shown in the Figure-1, located to the V_{CC} to hold on the V_{CC} during the M_2 on period is necessary. The ceramic type of capacitor is suitable for V_{CC} retaining, a $1\mu F$ capacitor could supply the operating current of the control circuit for tens microsecond with a very good voltage regulation.

Peak Current Detection and Line Voltage Compensation

In the Figure-3, a current flow through M_2 and R_S during the M_2 on period. This current caused the V_{CS} increasing, the comparator pass the peak current information to the control circuit to turn off M_2 while V_{CS} reach to 0.25V. The peak, I_{PK} , current could determine by (1):

$$I_{PK} = \frac{0.25}{R_S} \quad (1)$$

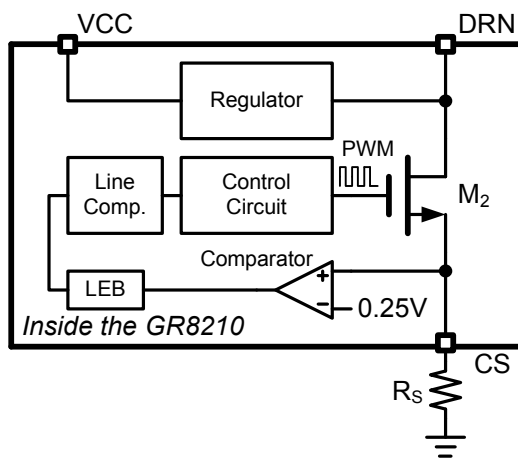

Figure-3 The brief schematic to explain the peak current detection and line voltage compensation.

In the Figure-4, there are large voltage spike in the turn on edge of V_{P1} to V_{P3} . These voltage spikes probably affect the wrong peak current detection. To prevent this fault, a LEB block applied in the GR8210 to generate a fixed period to blank the voltage spike in the CS.

The T_{pg} in the Figure-4 is the propagation delay of M_2 turned off. The T_{pg} was defined from the V_{CS} reaching 0.25V to M_2 turned off. In the T_{pg} period, the V_{CS} still ramps up from 0.25V due to the M_2 was not turned off yet. For that reason, the end of V_{CS} in the higher V_{IN} is greater than the end of V_{CS} in the lower V_{IN} .

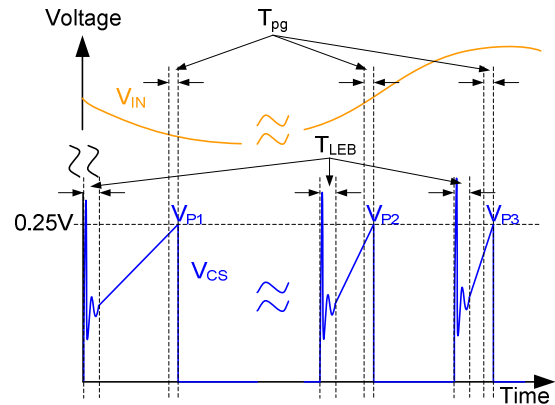
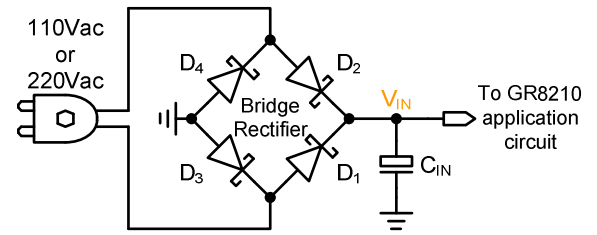

Figure-4 The waveforms of V_{IN} and V_{CS} to explain the operation of T_{LEB} and line voltage compensation. The sketch map explains the generation of V_{IN} and the line voltage change of V_{IN} due to the limited C_{IN} .

The different height of V_{CS} means the different I_{OUT} that shown in the Figure-1. The line voltage compensation function was applied in the GR8210 to improve the output current regulation. The V_{P1} to V_{P3} in the Figure-4 illustrates the compensation results by the line voltage compensation.

OFF Time Setting

GR8210 operates with the peak current sensing and the constant off time. The peak current sensing and the line voltage compensation align the peaks of V_{CS} identically to determine the same I_{PEAK} that shown in the Figure-5. The I_{VALLEY} was determined by the T_{OFF} . GR8210 provides an off time setting function via connect a resistor from R_T to GND. A simple way is connect R_T to VCC directly to use the default off time that the value is approximately 9.3 μ s.

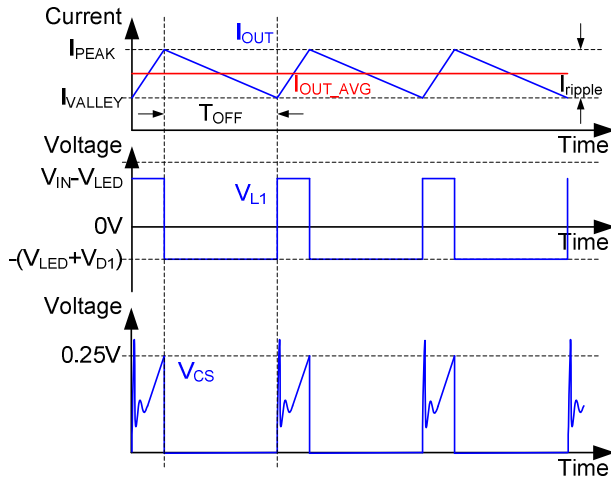

Figure-5 The waveforms of V_{CS} , V_{L1} and I_{OUT} that shown in the Figure-1.

Inductor Selection and Output Current Setting

The (2) and (3) were generated according to the Figure-5. They usually used to determine the inductance of the power inductor.

$$I_{ripple} = I_{OUT} \cdot K \quad (2)$$

$$L = \frac{(V_{LED} + V_{D1})}{I_{ripple}} \cdot T_{OFF} \quad (3)$$

Where, the I_{OUT} is output current that user defined, the K . is the percentage of I_{OUT} to estimate the worse case and the value usually is range of 20%~40%. Beside, the maximum rate current and saturation current of the inductor must greater than the I_{PEAK} that shown in the Figure-5.

R_s Selection

Base on the decision of L , we can calculate the R_s by (4).

$$R_s = \frac{0.5}{(2 + K) \cdot I_{OUT}} \quad (4)$$

Input Capacitor Selection

In the Figure-1, the C_{IN} retained the V_{IN} with ac part, the waveform was shown as Figure-6. Before the input capacitance decision, the users must define the input voltage ripple in the system. A useful rule

can find the valley voltage of the input voltage, add 5volts with the summation of the LED forward voltage and let the input valley voltage higher than this value.

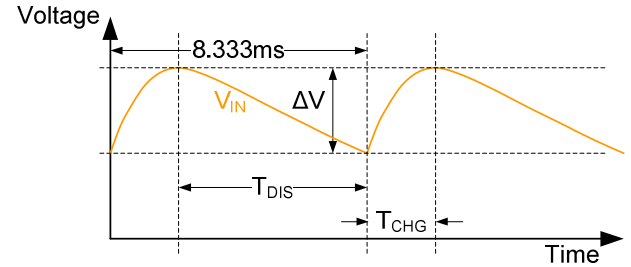

Figure-6 The waveform of input voltage in the C_{IN} .

The (5) to (7) could be used to estimate the capacitance of C_{IN} that shown in the Figure-1.

$$T_{CHG} = \frac{8.333m}{2} \cdot \left[1 - \frac{\sin^{-1}\left(1 - \frac{\Delta V}{V_{IN}}\right)}{90} \right] \quad (5)$$

$$T_{DIS} = 8.333m - T_{CHG} \quad (6)$$

$$C_{IN} = \frac{0.5 \cdot I_{OUT} \cdot T_{DIS}}{\Delta V} \quad (7)$$

Note that, the ΔV is the input voltage ripple that defined by the users, the T_{CHG} is the charging period and the T_{DIS} is the discharging period. In the other considerations, the maximum rate voltage of the C_{IN} must be greater than the peak value of V_{IN} , the maximum RMS current of C_{IN} must be greater than half I_{OUT} .

Freewheel Diode Selection

Two specifications of freewheel diode must be considered, the maximum reverse voltage must be greater than maximum voltage across the diode. The average rectified current also must be greater than I_{PEAK} that shown in the Figure-5. The ultra fast diode is recommended to use as the freewheel diode.

External NMOSFET Selection

The external NMOSFET in the Figure-1, M_1 , was connected to the DRN of the GR8210. Most of the input voltage was across the drain and source terminals of M_1 . The specifications of a suitable device are, the continuous current range of 1A to 2A, the maximum drain to source voltage is 600V and the maximum gate to source voltage is 20V. To choose an external NMOSFET with better specifications than above will not improve the efficiency significantly.

Zener Diode Selection

Users can select an external Zener diode to provide the gate voltage for the external NMOSFET. The range of the Zener voltage is 12V to 15V.

PWM Dimming Operation

The users could apply a digital duty modulation signal into DIM pin to use the PWM dimming. The I_{OUT} , shown in the Figure-1, would regulate in the high state of PWM signal and stop regulating in the low state of PWM signal.

Linear Dimming Operation

An analog dimming function was also applied in the GR8210. The users could apply an analog voltage that range from 0V to 0.5V into DIM pin to adjust the LED brightness. The DIM pin was a multi-function input. The GR8210 detects which dimming manner was applied after power on procedure. Therefore, the GR8210 can not alternate between PWM dimming and linear dimming during the operation.

Switching Dimming Operation

The GR8210 gives a very convenient switching dimming function for users without extra components and control signal input. The users could turn off the input power, shown as the V_{IN} in the Figure-7, right after that turn on the power again

during 1.5sec to dimming the brightness by the power switch. There are four current levels in the switching dimming operation. The level_1 to level_4 are determined by the V_{CS_SW1} to V_{CS_SW4} respectively.

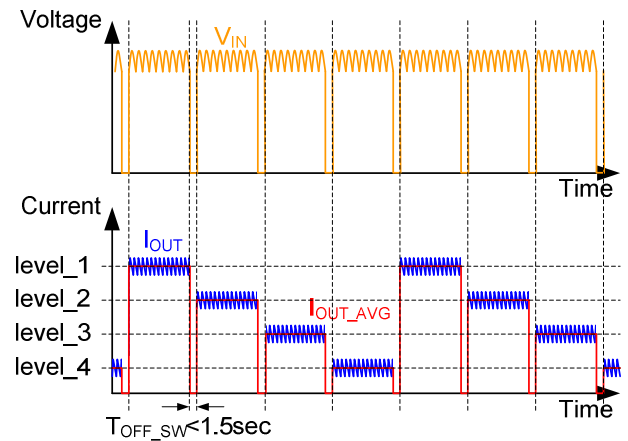

Figure-7 The waveforms of V_{IN} , I_{OUT} and I_{OUT_AVG} that shown in Figure-1. These waveforms illustrate the switching dimming procedure and behavior.

EN Function (Brown IN/OUT Operation)

The EN pin provides a control function to the users. The users can turn off the operation by apply a TTL logic signal via the EN pin.

Beside, EN pin can also used as a Brown IN/OUT function to make sure the operation under the suitable input voltage. In the lower input voltage, the GR8210 could stop operation via the brown in detection. The GR8210 detects the input voltage information by a voltage divider as shown in the Figure-8.

$$R_{BRN2} = \frac{0.9}{I_{BRN}} \quad (8)$$

$$R_{BRN1} = \frac{V_{IN_BRN} \cdot R_{BRN2}}{0.9} - R_{BRN2} \quad (9)$$

(8) and (9) can be used to estimate the resistance of the R_{BRN1} and R_{BRN2} . Note that, the I_{BRN} is the acceptable current by the users, the V_{IN_BRN} is the brown in voltage threshold set by the users.

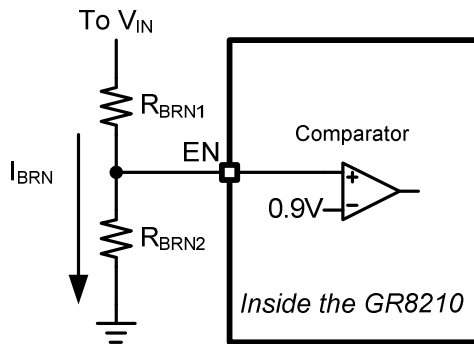

Figure-8 The sketch map of Brown In/Out setting.

Over Temperature Protection (OTP)

The GR8210 provides an inner over temperature protection function to prevent the system damage. In some abnormal situation, a high temperature could trip the OTP to latch off the GR8210. The users should power on again to reset this latch.

Short Circuit Protection

In the Figure-9, the I_{OUT} runs away due to the I_{VALLEY} always higher than I_{PEAK} in the short circuit conditions. To prevent this situation, the GR8210 could increase the T_{OFF} by product a multiplier to control the I_{VALLEY} stay below I_{PEAK} . The multiplier might be 2, 4 and 8 that decided by the GR8210 control scheme.

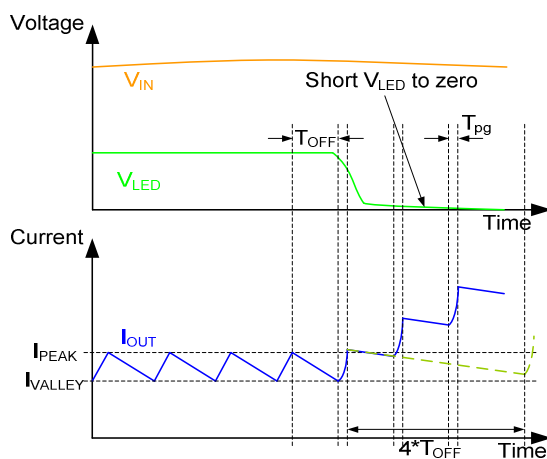
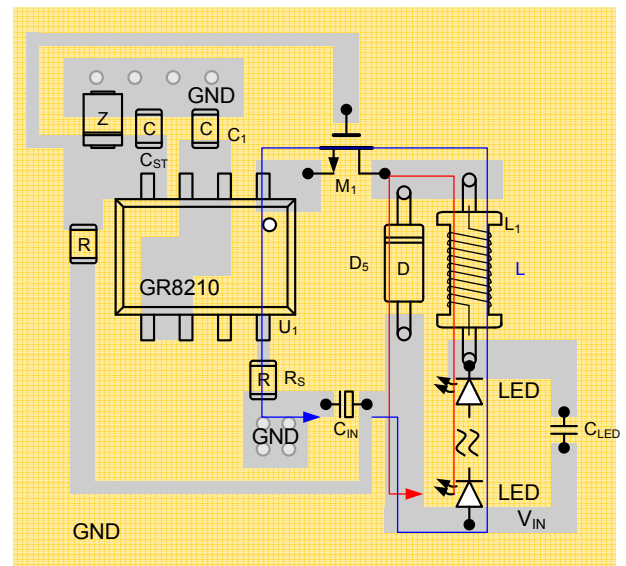

Figure-9 The sketch waveforms to illustrate the short circuits protection.

PCB Layout Consideration

Figure-10 shows the PCB layout considerations of GR8210. These guidelines detailed below.

- (1) Locate the U_1 , R_S , C_{IN} , D_5 , L_1 and M_1 closely each other to reduce the current loop of on period and off period.
- (2) Locate the R_S , C_1 and C_{ST} close to the GR8210 as possibly.
- (3) Locate the M_1 to the GR8210 close as possibly to reduce the distance between the source terminal of M_1 and pin1 of U_1 .



- Top Layer ■ Bottom Layer
- ON Period Current Loop
- OFF Period Current Loop

Figure-10 The PCB layout sketch map shown the layout considerations and the relative locations of the key components.

Typical Application Circuit

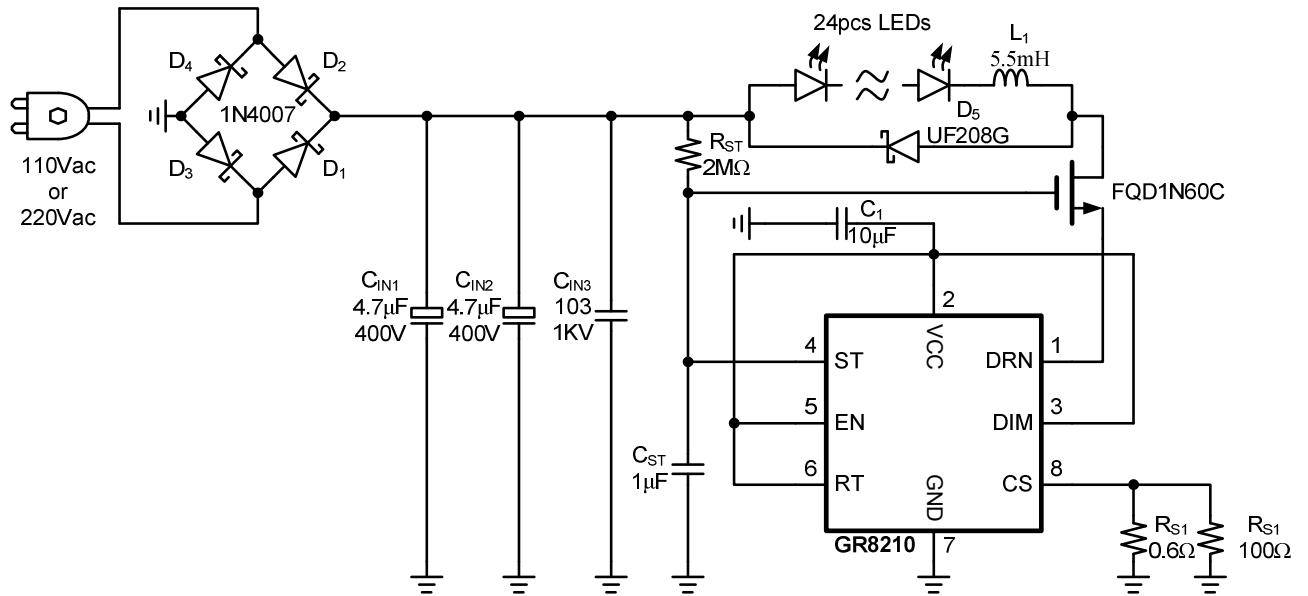
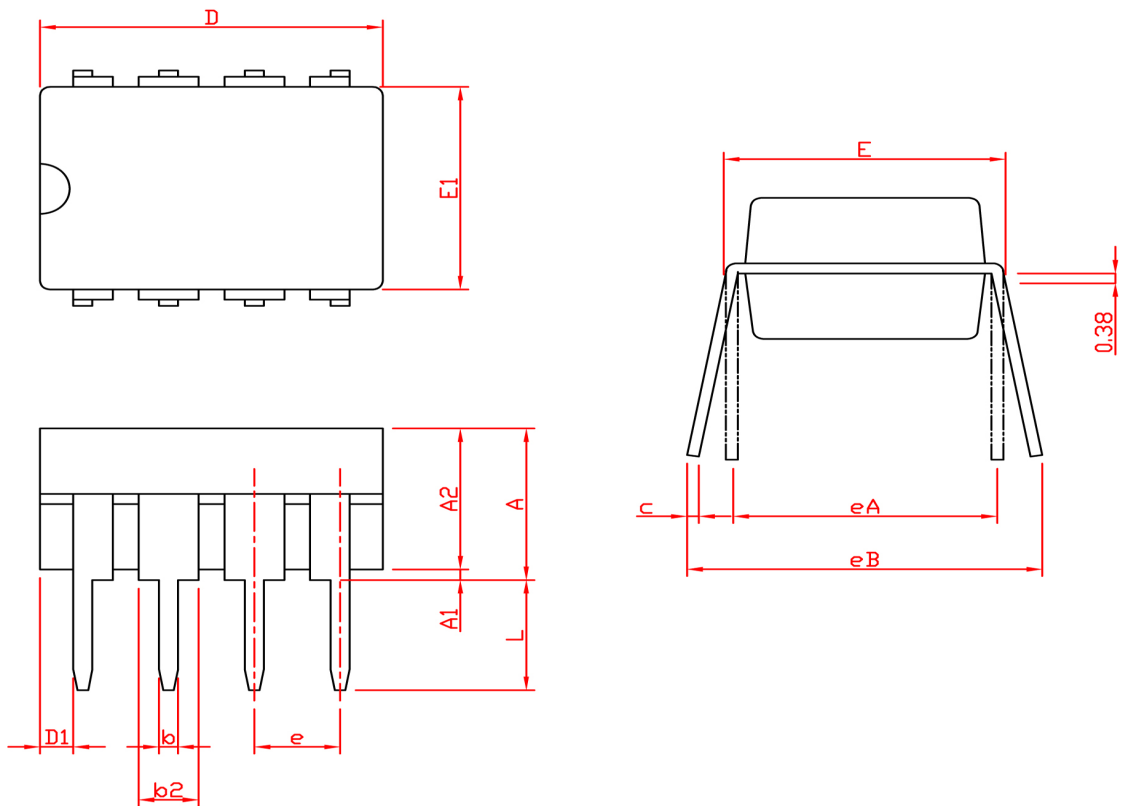
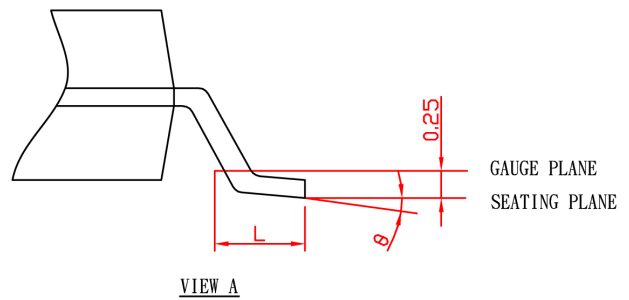
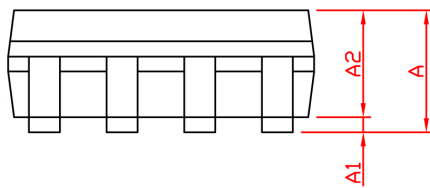
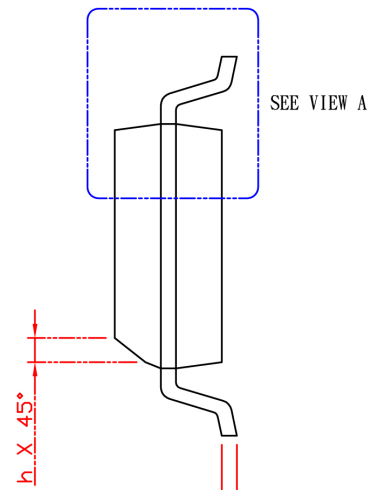
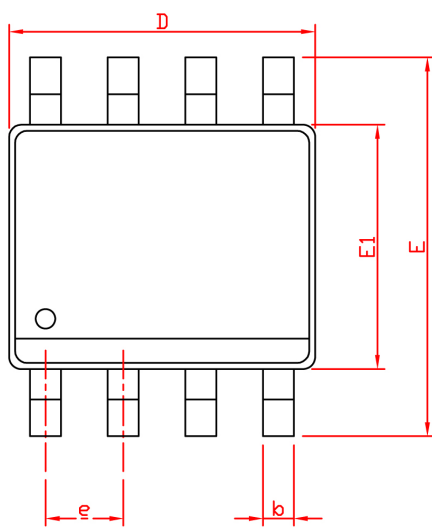

Figure-11 110Vac or 220Vac input voltage, default off time, 24pcs LEDs light bar, 350mA application circuit.

Package Information



SYMBOL	DIP-8			
	MILLIMETERS		INCHES	
	MIN.	MAX.	MIN.	MAX.
A		5.33		0.210
A1	0.38		0.015	
A2	2.92	4.95	0.115	0.195
b	0.36	0.56	0.014	0.022
b2	1.14	1.78	0.045	0.070
c	0.20	0.35	0.008	0.014
D	9.01	10.16	0.355	0.400
D1	0.13		0.005	
E	7.62	8.26	0.300	0.325
E1	6.10	7.11	0.240	0.280
e	2.54 BSC		0.100 BSC	
eA	7.62 BSC		0.300 BSC	
eB		10.92		0.430
L	2.92	3.81	0.115	0.150

Package Information

SYMBOL	SOP-8			
	MILLIMETERS		INCHES	
	MIN.	MAX.	MIN.	MAX.
A		1.75		0.069
A1	0.10	0.25	0.004	0.010
A2	1.25		0.049	
b	0.31	0.51	0.012	0.020
c	0.17	0.25	0.007	0.010
D	4.80	5.00	0.189	0.197
E	5.80	6.20	0.228	0.244
E1	3.80	4.00	0.150	0.157
e	1.27 BSC		0.050 BSC	
h	0.25	0.50	0.010	0.020
L	0.40	1.27	0.016	0.050
θ	0°	8°	0°	8°

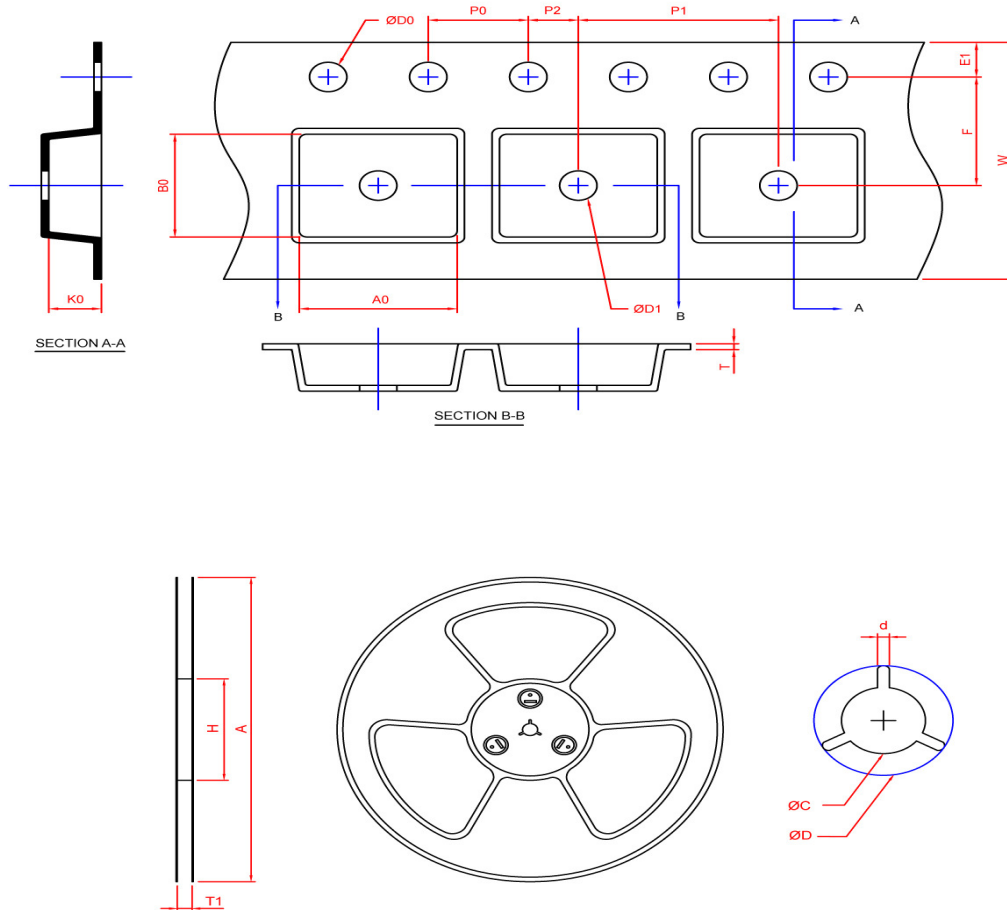
Carrier Tape & Reel Dimensions
SOP-8

Application	A	H	T1	C	d	D	W	E1	F
SOP-8	330.0±2.0	50 MIN.	12.4+2.00 -0.00	13.0+0.50 -0.20	1.5 MIN.	20.2 MIN.	12.0±0.30	1.75±0.10	5.5±0.05
	P0	P1	P2	D0	D1	T	A0	B0	K0
	4.0±0.10	8.0±0.10	2.0±0.05	1.5+0.10 -0.00	1.5 MIN.	0.6+0.00 -0.40	6.40±0.20	5.20±0.20	2.10±0.20

(mm)

Devices Per Unit

Application	Carrier Width	Cover Tape Width	Devices Per Reel
SOP-8	12	-	2500

Greenergy OPTO, Inc. reserves the right to make corrections, modifications, enhancements, improvements, and other changes to its products and services at any time and to discontinue any product or service without notice. Customers should obtain the latest relevant information before placing orders and should verify that such information is current and complete.