

M8 series



1-2W隔离稳压输出电源模块

1-2 Watt Isolated DC-DC Converter, Regulated Output

1、产品特点 Features

■ 2:1宽电压输入稳压单/双输出 Wide 2:1 InPut Voltage Range, Single/Double Output

■ 输入/输出隔离高压1.5KVdc Input/Output Isolation1.5KVdc

■ 低纹波系数和低噪音 Low Rippe and Noise

■ 转换效率:高达80%以上 Efficiency: up to 80%

■ 100%烧机老化测试 100% Burn-In

■ 符合ROSH指令要求 In line with RoHS codes

■ 可根据客户需求设计特殊规格产品 Custom Design Available

2、产品工作极限值 Absolute maximum ratings

(超出以下极限值使用,可能会损坏模块,模块不允许在极限值持续工作。)

(Exceeding these Values may damage the module. These are not continuous operating ratings)

项目 Parameter	条件 Condition	最小值 Min	标称值 Typ	最大值 Max	单位 Unit
输入电压范围 Input Absoute Voltage Range	12V输入模块 12V Input Model	-0.7	12	23	Vdc
	24V输入模块 24V Input Model	-0.7	24	45	
	48V输入模块 48V Input Model	-0.7	48	85	
输出短路情况 Output Short circuit duration	标称输入范围 Nominal Input Range	持续短路保护/过流保护(自恢复) Indefinite&Auto-restart			
工作温度范围 Operating temperature	输出为满载 Output Full Load	-40	---	+85	°C
存储温度 Storage temperature	---	-55	---	+105	

*请测试外壳的表面温度 To be measured at case plate temperature

3、产品输入/输出一般特性 Nominal Input/Out Electrical Specifications

(以下参数均在室温环境+25°C, 模块在标称输入电压下测试得到)

(Speci fications typical at Ta=+25°C, nominal input voltage, rated output current unless otherwise noted)

项目 Parameter	条件 Condition	最小值 Min	标称值 Typ	最大值 Max	单位 Unit
输入电压范围 Input Voltage Range	12V输入模块 12V Input Model	9	12	18	Vdc
	24V输入模块 24V Input Model	18	24	36	
	48V输入模块 48V Input Model	36	48	75	

负载调整率 Load Regulation	单输出模块 Single Output Model	---	---	±0.5	%
	双输出模块 Dual Output Model	---	---	±1.0	%
线性调整率 Line Regulation	输出为满载 Output Full Load	---	---	±0.5	%
交叉调整率 Load cross Regulation	双输出模块 Dual Output Model Load 20/100%	---	---	±5.0	%
输出电压精度 Output Voltage Accuracy	标称输入电压 Nominal Input	---	±1.0	±2.0	%
工作频率 Switching Frequency	标称输入电压 Nominal Input	---	200	230	KHz
温度漂移系数 Temperature Coefficient		---	±0.01	±0.02	%/°C
输入/输出隔离高压 Isolation Voltage	60Seconds/0.5mA	1500	---	---	Vdc
绝缘电阻 Isolation Resistance	500Vdc	1000	---	---	MΩ

4、模块选型指南 Selection Guide

(以下参数均在室温环境+25°C，模块在标称输入电压下测试得到)

(Specifications typical at Ta=+25°C, nominal input voltage, rated output current unless otherwise noted)

产品型号 Model No.	输入电压 Input Voltage (Vdc)	输出电压 Output Voltage (Vdc)	输出电流 Output Current (mA) Max	输入静态电流 Input Current @No Load (mA) Typ	满载输入 输入电流 @Max Load (mA) Typ	输出纹波 Output Ripple (mV) Typ	负载调整率 Load Regulation (%) Max	转换效率 Efficiency (%) typ
2W单输出系列 2W Single Output Series								
M8-123.3SS2L	12	3.3	606	5	214	36	±0.5	78
M8-1205SS2L		5	400	6	204	36	±0.5	82
M8-1209SS2L		9	222	7	208	36	±0.5	80
M8-1212SS2L		12	167	8	201	44	±0.5	83
M8-1215SS2L		15	133	9	204	56	±0.5	82
M8-1224SS2L		24	84	9	200	152	±0.5	84
M8-243.3SS2L	24	3.3	606	3	106	40	±0.5	80
M8-2405SS2L		5	400	3	101	40	±0.5	83
M8-2409SS2L		9	222	4	101	48	±0.5	83
M8-2412SS2L		12	167	4	103	36	±0.5	81
M8-2415SS2L		15	133	4	98	76	±0.5	85
M8-2424SS2L		24	84	5	98	192	±0.5	86
M8-483.3SS2L	48	3.3	606	2	53	40	±0.5	79
M8-4805SS2L		5	400	2	51	60	±0.5	82
M8-4809SS2L		9	222	3	51	56	±0.5	82

产品型号 Model No.	输入电压 Input Voltage (Vdc)	输出电压 Output Voltage (Vdc)	输出电流 Output Current (mA) Max	输入静态电流 Input Current @No Load (mA) Typ	满载输入 Input Current @Max Load (mA) Typ	输出纹波 Output Ripple (mV) Max	负载调整率 Load Regulation (%) Max	转换效率 Efficiency (%) typ
M8-4812SS2L	48	12	167	2	50	52	±0.5	84
M8-4815SS2L		15	133	3	49	88	±0.5	85
M8-4824SD2L		24	84	3	49	184	±0.5	86
2W双输出系列 2W dual Output Series								
M8-1205SD2L	12	±5	±100	8	207	±45	±0.5	81
M8-1209SD2L		±9	±112	10	207	±52	±0.5	81
M8-1212SD2L		±12	±84	10	203	±64	±0.5	82
M8-1215SD2L		±15	±67	10	202	±70	±0.5	82
M8-2405SD2L	24	±5	±100	5	104	±45	±0.5	80
M8-2409SD2L		±9	±112	6	102	±52	±0.5	81
M8-2412SD2L		±12	±84	5	100	±80	±0.5	84
M8-2415SD2L		±15	±67	6	98	±75	±0.5	84
M8-4805SD2L	48	±5	±100	3	52	±72	±0.5	81
M8-4809SD2L		±9	±112	4	51	±68	±0.5	81
M8-4812SD2L		±12	±84	4	51	±64	±0.5	82
M8-4815SD2L		±15	±67	4	50	±72	±0.5	83
M8-XXXXSXXL								

备注:

- 1、以上均为标准输出电压，即3.3V, 5V, 9V, 12V, 15V. M8-XXXXSXXL为根据客户需求设计产品。
- 2、负载调整率是指输出负载电流从满载输出电流的0到100%变化时，输出电压的变化情况。负载调整率是电源选型的重要指标之一，另外还有电源的转换效率，输出纹波等参数均是电源选型考虑的要素。
- 3、本系列产品具有逻辑电平控制电源开和关的功能,以降低系统静态损耗。

5、外观尺寸和引脚定义 Mechanical Dimension

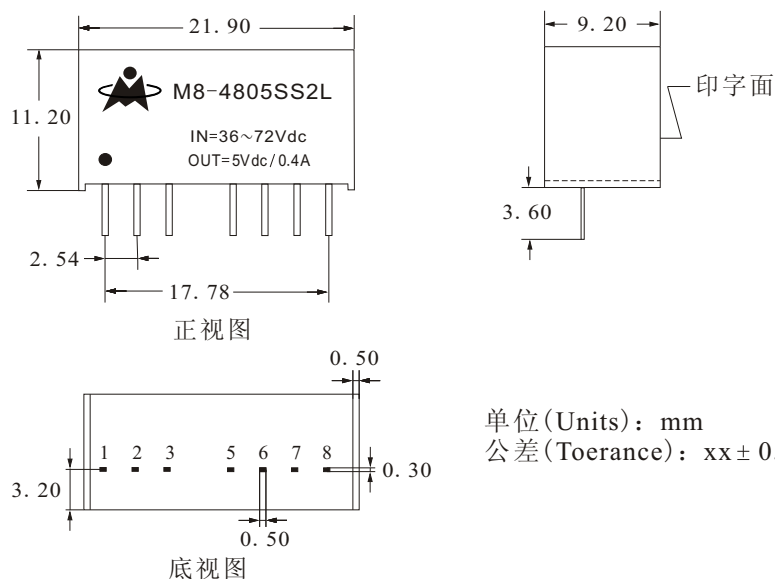

Pin	1.5KVdc-Single	1.5KVdc-Dual
1	-Vin	-Vin
2	+Vin	+Vin
3	Ve	Ve
4	---	---
5	NC	NC
6	+Vout	+Vout
7	-Vout	Com
8	Cext	+Vout

备注:
“---”表示没有此引脚
“Ve”即逻辑电平输入脚
“NC”表示此引脚没有电气输出
“Cext”表示此脚和6脚电气是连接的。

7、产品工作降额曲线图

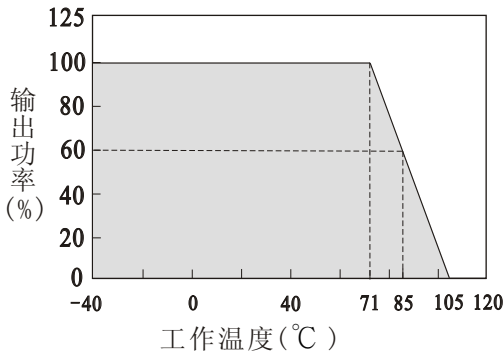

8、产品典型效率曲线图

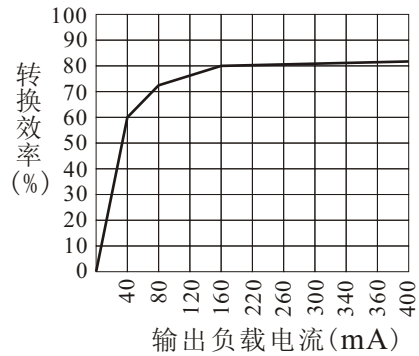

9、产品命名

举例：

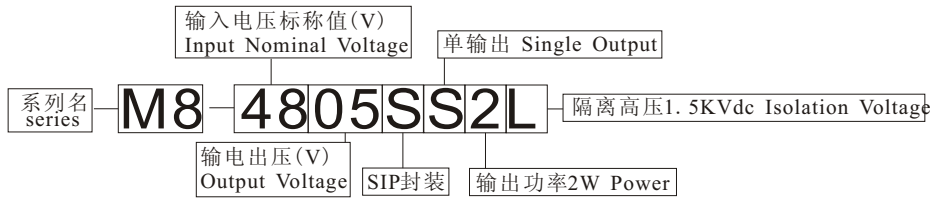

10、产品外围推荐电路

① 推荐电路

对于纹波要求较高的场合，可在输入端并联一颗滤波电容，输出端连接一个“LC”滤波网路，外接电路如下图所示，滤波电容和电感的选择要合适，滤波电容容值不能选得太大，否则可能会造成模块启动不良，其滤波电容电感的推荐值详见（表1）

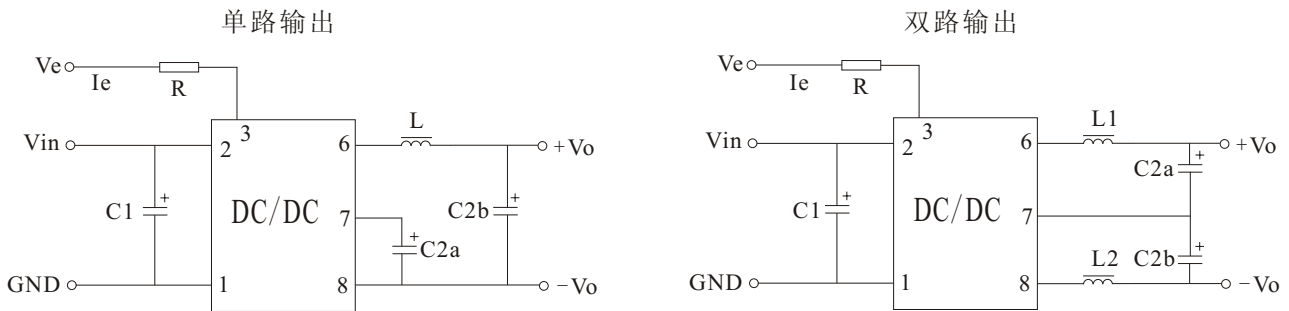

输出电压 Output Voltage (V)	C1 (uF/V)	C2a, C2b (uF/V)	L1, L2 (uH)
3, 3, 5	100/25	47/10	10-33
9, 12	47/50	10/25	10-33
15, 24	10/100	4.7/50	10-33

(表1)

② Ve端

② Ve端

悬空或接地时，模块正常输出；接高电平（相对于输入地），模块关断；注意流入该引脚的电流（Ie）在5-10mA为宜，电流超过其最大值（一般为20mA）会造成模块的永久损坏！其中R值可按 $R = \frac{V_e}{I_e}$ 公式得到。

③ 输入要求

确保供电电源的输出电压波动范围不要超出DC/DC模块本身的输入要求。输入电源的输出功率必须大于DC/DC模块的输出功率。