

Powder Cores

- Molypermalloy
- High Flux
- Kool Mu





MAGNETICS offers the confidence of over fifty years of expertise in the research, design, manufacture and support of high quality magnetic materials and components.

A major supplier of the highest performance materials in the industry including: MPP, High Flux, Kool M μ [®], power ferrites, high permeability ferrites and strip wound cores, Magnetics' products set the standard for providing consistent and reliable electrical properties for a comprehensive range of core materials and geometries. Magnetics is the best choice for a variety of applications ranging from simple chokes and transformers used in telephone equipment to sophisticated devices for aerospace electronics.

Magnetics backs its products with unsurpassed technical expertise and customer service. Magnetics' Application Engineering staff offers the experience necessary to assist the designer from the initial design phase through prototype approval. The knowledgeable Sales staff is available to help with all of your customer service needs. This support, combined with a global presence via a worldwide distribution network, including a Hong Kong distribution center, makes Magnetics a premier supplier to the international electronics industry.

LITERATURE AVAILABLE AT www.mag-inc.com

PRODUCT LITERATURE AND DESIGN SOFTWARE CD

CONTAINS

- All Product Literature
- Common Mode Filter Design Software
- Current Transformer Design Software
- Inductor Design Software
- Mag Amp Design Software

POWDER CORE LITERATURE

- MPP-T1 MPP THINZ Technical Bulletin
- KMC-S1 Kool M μ Application Notes
- KMC-E1 Kool M μ E Core Technical Bulletin
- CG-03 Cores For Flybacks

FERRITE LITERATURE

- FC-601 Design Manual
- FC-S1 Ferrite Material Selection Guide
- FC-S2 EMI/RFI Common Mode Filters
- FC-S3 Q Curves for Ferrite Cores
- FC-S4 Step Gap E-cores, Swinging Chokes
- FC-S5 Common Mode Inductors for EMI
- FC-S7 Curve Fit Equations for Ferrite Materials
- FC-S8 Designing with Planar Ferrite Cores
- CG-01 A Critical Comparison of Ferrites with other Magnetic Materials

TAPE WOUND CORE LITERATURE

- TWC-600 Design Manual
- TWC-S1 Fundamentals of Tape Wound Core Design
- TWC-S2 How to Select the Proper Core for Saturating Transformers
- TWC-S3 Inverter Transformer Core Design and Material Selection
- SR-4 Mag Amp Control in SMPS
- SR-6 Reduction of Control-loop Interactions in Mag Amps

BOBBIN CORE LITERATURE

- BCC-1.1 Design manual

GENERAL INFORMATION

- APB-2 All Products Bulletin
- CG-02 Material Selection Charts for Frequency, Temperature, Geometry, Stability
- CG-05 Frequently Asked Questions About MAGNETICS Materials
- CG-06 Designing With Magnetic Cores at High Temperature
- SR-1A Inductor Design in Switching Regulators
- PS-01 Cores for SMPS
- PS-02 Magnetic Cores for Switching Power Supplies
- HED-01 Cores for Hall Effect Devices
- RC-1 Cores for Ground Fault Interrupters



CONTENTS

SECTION 1

GENERAL INFORMATION

- 1-1 Introduction
- 1-2 Applications
- 1-3 Core Identification
- 1-4 General Powder Core Information

SECTION 2

CORE SELECTION

- 2-1 Core Selection Procedure
- 2-2 Core Selection Example
- 2-3 Core Selector Charts

SECTION 3

TECHNICAL DATA

- 3-1 Material Properties
- 3-2 Conversion Tables
- 3-3 Normal Magnetization Curves
- 3-5 Core Loss Density Curves
- 3-12 Permeability versus Temperature Curves
- 3-15 Permeability versus DC Bias Curves
- 3-17 Permeability versus AC Flux Curves
- 3-19 Permeability versus Frequency Curves
- 3-21 Wire Table

SECTION 4

CORE DATA

- 4-1 Toroid Data
- 4-31 Kool M μ ® E Core Data
- 4-33 MPP THINZ™ Data

SECTION 5

HARDWARE

- 5-1 Toroid Mounts
- 5-5 Kool M μ ® E Core Bobbins



MPP Core Locator & Unit Pack Quantity

P/N	PAGE	QTY	P/N	PAGE	QTY	P/N	PAGE	QTY	P/N	PAGE	QTY
55015	4-4	2500	55118	4-14	2500	55265	4-6	2500	55407	4-7	2500
55016	4-4	2500	55120	4-14	2500	55266	4-6	2500	55408	4-7	2500
55017	4-4	2500	55121	4-14	2500	55267	4-6	2500	55410	4-7	2500
55018	4-4	2500	55122	4-14	2500	55268	4-6	2500	55411	4-7	2500
55020	4-4	2500	55123	4-14	2500	55270	4-6	2500	55412	4-7	2500
55021	4-4	2500	55125	4-12	2500	55271	4-6	2500	55413	4-7	2500
55022	4-4	2500	55127	4-12	2500	55272	4-6	2500	55433	4-24	120
55023	4-4	2500	55128	4-12	2500	55273	4-6	2500	55435	4-24	120
55025	4-8	2500	55130	4-12	2500	55275	4-9	2500	55436	4-24	120
55026	4-8	2500	55131	4-12	2500	55276	4-9	2500	55438	4-24	120
55027	4-8	2500	55132	4-12	2500	55277	4-9	2500	55439	4-24	120
55028	4-8	2500	55133	4-12	2500	55278	4-9	2500	55440	4-24	120
55030	4-8	2500	55135	4-1	1550	55280	4-9	2500	55441	4-24	120
55031	4-8	2500	55137	4-1	1550	55281	4-9	2500	55543	4-20	300
55032	4-8	2500	55138	4-1	1550	55282	4-9	2500	55544	4-20	300
55033	4-8	2500	55140	4-1	1550	55283	4-9	2500	55545	4-20	300
55035	4-11	2500	55145	4-2	750	55285	4-10	2500	55546	4-20	300
55036	4-11	2500	55147	4-2	750	55286	4-10	2500	55548	4-20	300
55037	4-11	2500	55148	4-2	750	55287	4-10	2500	55550	4-20	300
55038	4-11	2500	55150	4-2	750	55288	4-10	2500	55551	4-20	300
55040	4-11	2500	55175	4-3	600	55290	4-10	2500	55580	4-21	300
55041	4-11	2500	55177	4-3	600	55291	4-10	2500	55581	4-21	300
55042	4-11	2500	55178	4-3	600	55292	4-10	2500	55582	4-21	300
55043	4-11	2500	55180	4-3	600	55293	4-10	2500	55583	4-21	300
55045	4-13	2500	55181	4-3	600	55305	4-17	1000	55585	4-21	300
55046	4-13	2500	55190	4-27	100	55306	4-17	1000	55586	4-21	300
55047	4-13	2500	55191	4-27	100	55307	4-17	1000	55587	4-21	300
55048	4-13	2500	55192	4-27	100	55308	4-17	1000	55588	4-21	300
55050	4-13	2500	55195	4-27	100	55310	4-17	1000	55710	4-26	100
55051	4-13	2500	55197	4-27	100	55312	4-17	1000	55712	4-26	100
55052	4-13	2500	55199	4-27	100	55313	4-17	1000	55713	4-26	100
55053	4-13	2500	55201	4-16	1000	55319	4-22	300	55715	4-26	100
55059	4-17	1000	55202	4-16	1000	55320	4-22	300	55716	4-26	100
55071	4-20	300	55203	4-16	1000	55321	4-22	300	55717	4-26	100
55076	4-22	300	55204	4-16	1000	55322	4-22	300	55718	4-26	100
55083	4-23	200	55206	4-16	1000	55324	4-22	300	55848	4-16	1000
55084	4-25	120	55208	4-16	1000	55326	4-22	300	55866	4-29	27
55086	4-25	120	55209	4-16	1000	55327	4-22	300	55867	4-29	27
55087	4-25	120	55235	4-5	2500	55345	4-18	500	55868	4-29	27
55089	4-25	120	55236	4-5	2500	55347	4-18	500	55869	4-29	27
55090	4-25	120	55237	4-5	2500	55348	4-18	500	55894	4-19	500
55091	4-25	120	55238	4-5	2500	55350	4-18	500	55906	4-30	27
55092	4-25	120	55240	4-5	2500	55351	4-18	500	55907	4-30	27
55104	4-28	100	55241	4-5	2500	55352	4-18	500	55908	4-30	27
55106	4-28	100	55242	4-5	2500	55353	4-18	500	55909	4-30	27
55107	4-28	100	55243	4-5	2500	55375	4-15	2500	55925	4-19	500
55109	4-28	100	55249	4-23	200	55377	4-15	2500	55926	4-19	500
55110	4-28	100	55250	4-23	200	55378	4-15	2500	55927	4-19	500
55111	4-28	100	55251	4-23	200	55380	4-15	2500	55928	4-19	500
55112	4-28	100	55252	4-23	200	55381	4-15	2500	55930	4-19	500
55115	4-14	2500	55254	4-23	200	55382	4-15	2500	55932	4-19	500
55116	4-14	2500	55256	4-23	200	55383	4-15	2500	55933	4-19	500
55117	4-14	2500	55257	4-23	200	55405	4-7	2500			

High Flux Core Locator & Unit Pack Quantity

P/N	PAGE	QTY	P/N	PAGE	QTY	P/N	PAGE	QTY
58018	4-4	2500	58191	4-27	100	58353	4-18	500
58020	4-4	2500	58192	4-27	100	58378	4-15	2500
58021	4-4	2500	58195	4-27	100	58380	4-15	2500
58022	4-4	2500	58204	4-16	1000	58381	4-15	2500
58023	4-4	2500	58206	4-16	1000	58382	4-15	2500
58028	4-8	2500	58208	4-16	1000	58383	4-15	2500
58030	4-8	2500	58209	4-16	1000	58408	4-7	2500
58031	4-8	2500	58238	4-5	2500	58410	4-7	2500
58032	4-8	2500	58240	4-5	2500	58411	4-7	2500
58033	4-8	2500	58241	4-5	2500	58412	4-7	2500
58038	4-11	2500	58242	4-5	2500	58413	4-7	2500
58040	4-11	2500	58243	4-5	2500	58438	4-24	120
58041	4-11	2500	58252	4-23	200	58439	4-24	120
58042	4-11	2500	58254	4-23	200	58440	4-24	120
58043	4-11	2500	58256	4-23	200	58441	4-24	120
58048	4-13	2500	58257	4-23	200	58546	4-20	300
58050	4-13	2500	58268	4-6	2500	58548	4-20	300
58051	4-13	2500	58270	4-6	2500	58550	4-20	300
58052	4-13	2500	58271	4-6	2500	58551	4-20	300
58053	4-13	2500	58272	4-6	2500	58583	4-21	300
58059	4-17	1000	58273	4-6	2500	58585	4-21	300
58071	4-20	300	58278	4-9	2500	58586	4-21	300
58076	4-22	300	58280	4-9	2500	58587	4-21	300
58083	4-23	200	58281	4-9	2500	58588	4-21	300
58089	4-25	120	58282	4-9	2500	58715	4-26	100
58090	4-25	120	58283	4-9	2500	58716	4-26	100
58091	4-25	120	58288	4-10	2500	58717	4-26	100
58092	4-25	120	58290	4-10	2500	58718	4-26	100
58109	4-28	100	58291	4-10	2500	58848	4-16	1000
58110	4-28	100	58292	4-10	2500	58866	4-29	27
58111	4-28	100	58293	4-10	2500	58867	4-29	27
58112	4-28	100	58308	4-17	1000	58868	4-29	27
58118	4-14	2500	58310	4-17	1000	58869	4-29	27
58120	4-14	2500	58312	4-17	1000	58894	4-19	500
58121	4-14	2500	58313	4-17	1000	58906	4-30	27
58122	4-14	2500	58322	4-22	100	58907	4-30	27
58123	4-14	2500	58324	4-22	300	58908	4-30	27
58128	4-12	2500	58326	4-22	300	58909	4-30	27
58130	4-12	2500	58327	4-22	300	58928	4-19	500
58131	4-12	2500	58349	4-18	500	58930	4-19	500
58132	4-12	2500	58350	4-18	500	58932	4-19	500
58133	4-12	2500	58351	4-18	500	58933	4-19	500
58190	4-27	100	58352	4-18	500			

Kool M μ [®] Core Locator & Unit Pack Quantity

P/N	PAGE	QTY	P/N	PAGE	QTY	P/N	PAGE	QTY
77020	4-4	2500	77210	4-16	1000	77411	4-7	2500
77021	4-4	2500	77211	4-16	1000	77414	4-7	2500
77030	4-8	2500	77213	4-28	100	77415	4-7	2500
77031	4-8	2500	77214	4-28	100	77438	4-24	120
77040	4-11	2500	77224	4-14	2500	77439	4-24	120
77041	4-11	2500	77225	4-14	2500	77440	4-24	120
77050	4-13	2500	77240	4-5	2500	77442	4-24	120
77051	4-13	2500	77241	4-5	2500	77443	4-24	120
77054	4-13	2500	77244	4-5	2500	77444	4-1	1550
77055	4-13	2500	77245	4-5	2500	77445	4-1	1550
77059	4-17	1000	77254	4-23	200	77548	4-20	300
77071	4-20	300	77256	4-23	200	77550	4-20	300
77076	4-22	300	77258	4-23	200	77552	4-20	300
77083	4-23	200	77259	4-23	200	77553	4-20	300
77089	4-25	120	77270	4-6	2500	77585	4-21	300
77090	4-25	120	77271	4-6	2500	77586	4-21	300
77091	4-25	120	77280	4-9	2500	77587	4-21	300
77093	4-25	120	77281	4-9	2500	77589	4-21	300
77094	4-25	120	77290	4-10	2500	77590	4-21	300
77109	4-28	100	77291	4-10	2500	77715	4-26	100
77110	4-28	100	77294	4-10	2500	77716	4-26	100
77111	4-28	100	77295	4-10	2500	77717	4-26	100
77120	4-14	2500	77310	4-17	1000	77719	4-26	100
77121	4-14	2500	77312	4-17	1000	77720	4-26	100
77130	4-12	2500	77314	4-17	1000	77824	4-4	2500
77131	4-12	2500	77315	4-17	1000	77825	4-4	2500
77140	4-1	1550	77324	4-22	300	77834	4-8	2500
77141	4-1	1550	77326	4-22	300	77835	4-8	2500
77150	4-2	750	77328	4-22	300	77844	4-11	2500
77151	4-2	750	77329	4-22	300	77845	4-11	2500
77154	4-2	750	77334	4-12	2500	77848	4-16	1000
77155	4-2	750	77335	4-12	2500	77868	4-29	27
77180	4-3	600	77350	4-18	500	77874	4-6	2500
77181	4-3	600	77351	4-18	500	77875	4-6	2500
77184	4-3	600	77352	4-18	500	77884	4-6	2500
77185	4-3	600	77354	4-18	500	77885	4-6	2500
77191	4-27	100	77355	4-18	500	77894	4-19	500
77192	4-27	100	77380	4-15	2500	77908	4-30	27
77193	4-27	100	77381	4-15	2500	77930	4-19	500
77194	4-27	100	77384	4-15	2500	77932	4-19	500
77195	4-27	100	77385	4-15	2500	77934	4-19	500
77206	4-16	1000	77410	4-7	2500	77935	4-19	500

Introduction

MAGNETICS Molypermalloy Powder (MPP) cores are distributed air gap toroidal cores made from a 79% nickel, 17% iron, and 4% molybdenum alloy powder for the lowest core losses of any powder core material.

MPP cores possess many outstanding magnetic characteristics, such as high resistivity, low hysteresis and eddy current losses, excellent inductance stability after high DC magnetization or under high DC bias conditions and minimal inductance shift up to 2,000 gauss under AC conditions.

MAGNETICS High Flux powder cores are distributed air gap toroidal cores made from a 50% nickel - 50% iron alloy powder for the highest available biasing capability of any powder core material.

High Flux cores have certain advantages that make them quite useful for applications involving high power, high dc bias, or high ac bias at high power frequencies. High Flux cores have a saturation flux density of 15,000 gauss, as compared to 7,500 gauss for standard MPP cores or 4,500 gauss for ferrites. The core loss of High Flux powder cores is significantly lower than that of powdered iron cores. It is possible that High Flux cores will offer a reduction in core size over powdered iron cores in most applications.

MAGNETICS Kool M μ [®] powder cores are distributed air gap cores made from a ferrous alloy powder for low losses at elevated frequencies. The near zero magnetostriction alloy makes Kool M μ ideal for eliminating audible frequency noise in filter inductors.

In high frequency applications, core losses of powdered iron, for instance, can be a major factor in contributing to undesirable temperature rises. Hence, Kool M μ cores are ideal because their losses are significantly less, resulting in lower temperature rises. It is possible that Kool M μ cores will offer a reduction in core size over powdered iron cores in a similar application.



Kool M μ E Cores have a distributed air gap which makes them ideally suited for switching regulator inductors, flyback transformers, and power factor correction (PFC) inductors. The 10,500 gauss saturation level of Kool M μ provides a higher energy storage capability than can be obtained with gapped ferrite E cores, resulting in smaller core size. Kool M μ E cores are competitively priced against gapped ferrite E cores and their distributed air gap eliminates gap loss problems associated with ferrites. Kool M μ E cores have significantly lower losses and substantially better thermal properties when compared to powdered iron E cores.

MPP THINZ™, or Molypermalloy Powder washer cores, are distributed air gapped toroidal cores made from an 81% nickel, 17% iron, and 2% molybdenum alloy powder having the highest permeability of any powder core material and significantly higher saturation flux density compared to discrete gapped ferrite. THINZ™ offer an extremely low height self shielded power inductor core allowing finished inductor heights in the 1.5 mm to 2 mm range. Excellent temperature stability, superior inductance under DC bias, and low core losses highlight this product line's outstanding magnetic properties.

Applications

MAGNETICS powder cores are primarily used in power inductor applications, specifically in switch-mode power supply (SMPS) output filters, also known as DC Inductors. Other power applications include differential inductors, boost inductors, buck inductors, and flyback transformers.

While all three materials are used in these applications, each has its own advantage. For the lowest loss inductor, MPP material should be used

since it has the lowest core loss. For the smallest core size in a dc bias dominated design, High Flux material should be used since it has the highest flux capacity. For reasonably low losses and reasonably high saturation at a low cost, Kool M μ [®] should be used since it has the lowest material costs.

Other specialty applications, such as High Q low level filters, load coils, and temperature stabilized inductors, MPP material is used.

	MPP	High Flux	Kool M μ
Permeability	14-550	14-160	26-125
Core Loss	Lowest	Moderate	Low
Perm vs. DC Bias	Better	Best	Good
Saturation (B_{sat})	7.5 Kilogauss	15 Kilogauss	10.5 Kilogauss
Nickel Content	80%	50%	0%
Relative Cost	High	Medium	Low

Core Identification

Magnetics toroids, E cores, and THINZ cores have unique part numbers that provide important information about the characteristics of the cores. A description of each type of part number is provided below.

TOROIDS C055206A2

Core Finish Code	Voltage Breakdown	Material Availability	O.D. Size Availability	Permeability Availability
A2	500 volts	MPP, High Flux	All	All
A5	1000 volts	MPP, High Flux	6.35 - 57.2 mm	60μ - 200μ
A7	500 volts	Kool Mμ	All	All
A9	4000 volts	MPP, High Flux	6.35 - 57.2 mm	60μ - 200μ
AY	300 volts	All	3.56 - 16.5 mm	14μ - 300μ
D4	500 volts	MPP	6.35 - 57.2 mm	60μ - 200μ
L6	500 volts	MPP	6.35 - 57.2 mm	60μ - 200μ
M4	500 volts	MPP	6.35 - 57.2 mm	60μ - 200μ
W4	500 volts	MPP	6.35 - 57.2 mm	60μ - 200μ

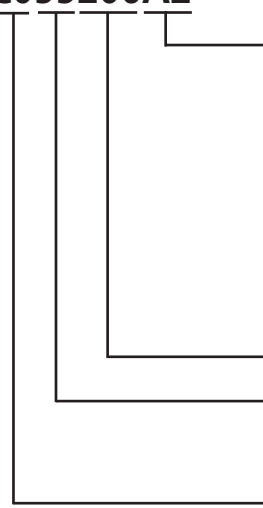

Catalog number (designates size and permeability)
 Material Code55 = MPP
 58 = High Flux
 77 = Kool Mμ
 Grading CodeC0 = Graded into 2% inductance bands
 00 = Not graded

POWDER CORE TOROID STAMPING SUMMARY

Size (O.D. mm)	6-digit Shop Order Number	2-digit Material Code	3-digit Catalog Number	2-digit Core Finish Code	Inductance Code	Example
6.35 - 6.86	✓		✓		✓	123456 020 +6
7.87 - 12.7	✓		✓	✓	✓	123456 050A2 +6
> 12.7	✓	✓	✓	✓	✓	123456 55120A2 +6

- Inductance Code is only stamped on MPP toroids with CO Grading Code
- Cores with O.D. less than 6.35 mm are not stamped

E CORES and THINZ 00K5528E060

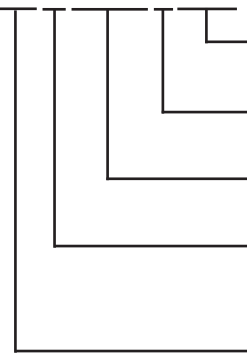

Permeability CodePermeability, e.g. 060 for 60μ
 Shape CodeE = E Core
 T = Toroid
 Size CodeFirst two digits equal approximate length or O.D. in mm
 Last two digits equal approximate height or I.D. in mm
 Material CodeM = MPP
 H = High Flux
 K = Kool Mμ
 Grading Code00 = Not graded

Core Finish

MAGNETICS powder cores are coated with a special finish that provides a tough, wax tight, moisture and chemical resistant barrier having excellent dielectric properties. Each material has a unique color coating:

Material	Color	Core Finish Codes
MPP	Gray	A2, A5, A9, D4 M4, W4, L6
HighFlux	Khaki	A2, A5, A9
Kool Mμ	Black	A7

The finish is tested for voltage breakdown by inserting the core between two weighted wire mesh pads. Force is adjusted to produce a uniform pressure of 10 psi, simulating winding pressure. The test condition to guarantee the minimum breakdown voltage (500 volts rms from wire to core) is a 60 Hz voltage equal to 2.5 times the minimum (or 1250 volts rms wire to wire). Higher minimum voltage breakdown finishes can be provided upon request for cores with greater than 5 mm O.D. There is no voltage breakdown guarantee on cores with less than 5 mm O.D.

Cores as large as 17.3 mm (0.680") O.D. can be coated with parylene to minimize the constriction of the inside diameter dimensions. The parylene coating has a minimum breakdown voltage guarantee of 300 volts rms from wire to core (tested at 750 volts rms wire to wire at 60 Hz). All finished dimensions in this catalog are for the color coating. When choosing a parylene coated core, the maximum O.D. and HT. are reduced by 0.18 mm (0.007"), and the minimum I.D. may be increased by 0.18 mm (0.007"). Use core finish code AY for parylene coating.

The maximum steady-state operating temperature for the coating is 200°C. The maximum steady-state operating temperature for the parylene coating is 130°C, but can be used as high as 200°C for short periods, such as during infrared solder reflow. High temperature operation of the cores does not affect the magnetic properties.

Core Inductance Tolerance/Grading

MAGNETICS powder cores are precision manufactured to an inductance tolerance of $\pm 8\%$ *, using standards obtained from Kelsall Permeameter Cup measurements and a precision series inductance bridge.

MPP cores with outside diameters greater than 5 mm are graded into 2% inductance bands as a standard practice at no additional charge. Grading into 1% bands is available on certain sizes by special request. Core grading minimizes winding adjustments, and thus reduces coil costs. When 1% bands are required, the wound cores must be processed for inductance stability (see Page 1-8).

Graded MAGNETICS MPP and High Flux cores are also available with tolerances less than the standard $\pm 8\%$. Please contact the plant for special pricing.

GRADE Stamped on Core O.D.	INDUCTANCE % Deviation from Nominal		TURNS % Deviation from Nominal	
	From	To	From	To
+8	+8	+7	-4.0	-3.5
+6	+7	+5	-3.5	-2.5
+4	+5	+3	-3.5	-1.5
+2	+3	+1	-0.5	+0.5
+0	+1	-1	-0.5	+0.5
-2	-1	-3	+0.5	+1.5
-4	-3	-5	+1.5	+2.5
-6	-5	-7	+2.5	+3.5
-8	-7	-8	+3.5	+4.0

14μ and 26μ cores are not graded.

* Kool Mμ cores with outside diameters less than 12 mm have wider tolerances.

Inductance versus Turns

MAGNETICS inductance standards are measured in a Kelsall Permeameter Cup. Actual wound inductance measured outside a Kelsall Cup is greater than the calculated value due to leakage flux and flux developed by the current in the winding. The difference depends on many variables — core size, permeability, core finish thickness, wire size, and number of turns, in addition to the way in which the windings are put on the core. This difference is negligible for permeabilities above 125 and turns greater than 500. However, the lower the permeability and/or number of turns, the more pronounced this deviation becomes.

The following table is presented as a guide to the differences that may be experienced with various numbers of turns on a 1-inch O.D. 125μ core:

Number of Turns	Actual Inductance
1000	+0.0%
500	+0.5%
300	+1.0%
100	+3.0%
50	+5.0%
25	+8.5%

The following formula can be used to approximate the leakage flux to add to the expected inductance. This formula was developed from historical data of cores tested at MAGNETICS. Be aware that this will only give an approximation based on evenly spaced windings. You may expect as much as a ±50% deviation from this result.

$$L_{LK} = \frac{292 N^{1.065} A_e}{l_e \times 10^5}$$

where : L_{LK} = leakage inductance (mH)
 N = number of turns
 A_e = core cross-section (cm²)
 l_e = core magnetic path length (cm)

A_L and Inductance Considerations

The inductance of a wound core can be calculated from the core geometry by using the following equation:

$$L = \frac{.4 \pi \mu N^2 A_e}{l_e \times 10^8}$$

where : L = inductance (Henries)
 μ = core permeability
 N = number of turns
 A_e = core cross section (cm²)
 l_e = core magnetic path length (cm)

The inductance for a given number of turns is related to the nominal inductance (as listed in the catalog as mH/1000 turns) by the following:

$$L_n = \frac{L_{1000} N^2}{10^6}$$

where : L_n = inductance for N turns (mH)
 L_{1000} = nominal inductance (mH/1000 turns)



MPP Temperature and Linear Stabilization

MAGNETICS MPP cores are provided in three basic temperature stabilizations; Standard, Controlled, and Linear. Typical and guaranteed inductance limits for these temperature stabilizations are illustrated on the following pages.

Standard cores are offered with three different finishes (A2, A5, or A9). Controlled and Linear cores are offered with a D4, M4, W4 and L6 finish, respectively. See page 1-3 for size and permeability availability.

The inductance of MPP cores is affected by temperature changes, which cause variations in the amount of distributed air gap (insulating material). The expansion characteristics of powdered metal, insulating material, and core finish all contribute to the inductance change arising from temperature changes.

The temperature coefficient of inductance can be controlled by the addition of a small percentage of special compensating alloys, which have curie points within the temperature range being controlled. When each curie point is exceeded, these particles become non-magnetic and act as additional air gaps; thus the change in inductance is minimized over a predetermined temperature range. MPP cores can thus be utilized in precision circuits requiring extremely high inductance stability over wide temperature ranges.

MAGNETICS standard cores (A2, A5, A9 Stabilization) offer the expected temperature performance shown on page 3-12. If guaranteed temperature performance is necessary, Controlled or Linear cores are recommended.

MAGNETICS MPP cores are offered in three controlled stabilizations, D4, W4, and M4 to provide high levels of inductance stability over temperature per the chart listed below. Stabilization is effective only to initial permeability or when cores are driven at low induction (<100 gauss).

MPP cores are also offered with linear temperature characteristics, L6. Linear cores provide a temperature coefficient, from -55°C to +85°C, which can be matched with a 100ppm polystyrene capacitor to yield extremely stable tuned circuits. Temperature coefficient values are referenced to 25°C.

The temperature stability of MPP cores can be affected by external factors such as moisture, winding stresses and potting compounds. These effects can be minimized by using suitable stability procedures during the coil fabrication process. Please see Inductor Stabilization Procedure on page 1-7.

Part No. Suffix	Stabilization Type	Inductance Stability Limits	Stabilized Temperature Range	Guaranteed Minimum Breakdown
D4	Controlled	±0.1%	0°C to +55°C +32°F to +130°F	500 volts
W4	Controlled	±.25%	-55°C to +85°C -67°F to +185°F	500 volts
M4	Controlled	±.25%	-65°C to +125°C -85°F to +257°F	500 volts
L6	Linear	See page 1-7	-55°C to +85°C -67°F to +185°F	500 volts

M4 cores meet the W4 core limits and may be substituted in place of W4.

Stabilized only available in 60-200 perm in O.D.s from 6.35 mm (0.25") - 57.2 mm (2.25").

MPP Linear Cores Guaranteed Limits

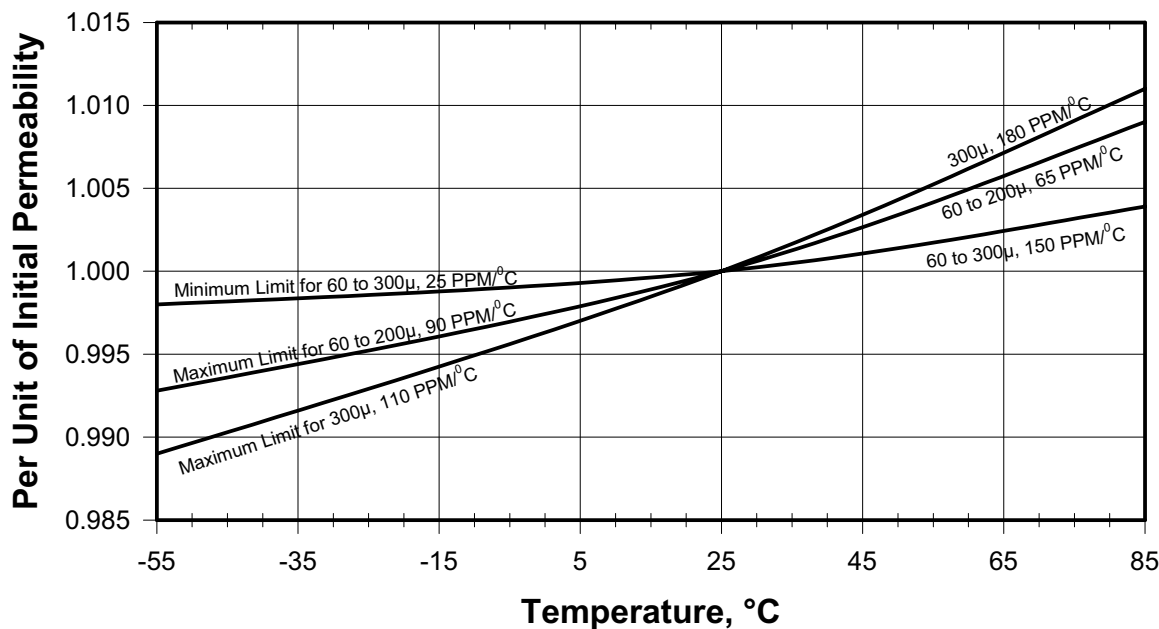

MPP Inductor Stabilization Procedure

MAGNETICS MPP cores possess excellent inductance/time stability. Under typical shelf life conditions the inductance of an unpotted core will shift less than 0.5%.

If maximum stability is desired, the following precautions and procedures will remove winding stresses and core moisture and provide inductance stabilities better than 0.05%.

1. Wind cores to the approximate specified inductance (slightly over the desired value).
2. Cool wound cores to -60°C . Maintain at temperature for 20 minutes to help relieve winding stresses caused by high winding tension, large wire, or many turns.
3. Heat cores slowly ($<2^{\circ}\text{C}/\text{minute}$) to 115°C . Maintain at temperature for 20 minutes.
4. Steps 2 and 3 should be repeated twice.
5. Bake at 115°C for 16 hours.
6. Cool to room temperature and adjust turns to obtain specified inductance.
7. Cores must be kept dry until potted or hermetically sealed.
8. If the cores are to be potted, they should be covered first with a cushioning material, such as silicone rubber. This material minimizes the possibility of the potting compound stressing the core and changing the inductance value.
9. Potting compounds should be chosen with care, as even semi-flexible resins can cause core stresses and reduce stability. Selection should be based on minimum shrinkage and minimum moisture absorption.

Winding Considerations

Winding Factors

MAGNETICS core winding factors can vary from 20% to 60%, a typical value in many applications being 40%.

MAGNETICS has chosen to normalize winding data by basing R_{dc} , ohm/mh, and winding-turn-length on unity winding factor. This approach provides the coil designer with a means of calculating realistic design parameters for his choice of winding factor.

Please note that unity values are theoretical values, not attainable in practice. The highest winding factor possible, even with hand winding, is 65% - 75%, due to the spacing between the turns of wire.

Winding Turn Length

Winding turn lengths have been computed, using empirical relationships, for five winding factors. This permits an estimate of the actual length/turn for any winding factor.

Wound Coil Dimensions

Wound coil dimensions are listed for unity winding factor, as these are the largest dimensions necessary for packaging the wound coil. These dimensions are attainable, as a 70% winding factor (no residual hole) yields the same overall coil dimensions as a 100% (unity) winding factor (no interstices).

Coil dimensions for coils wound to 40% winding factor can be estimated as follows:

$$O.D._{40\%} = .5 (O.D._{core} + O.D._{unity})$$

where : $O.D._{core}$ = core O.D. after finish

$O.D._{unity}$ = wound coil O.D.

$$HT_{40\%} = .45 (HT_{core} + HT_{unity})$$

where : HT_{core} = core O.D. after finish

HT_{unity} = wound coil O.D.

Temperature Rise Calculations

Temperature rise in a wound core depends on (1) wire resistance and current through the coil (P_{cu} , copper losses), and (2) core excitation (P_{fe} , core losses). Total power loss, defined as $P_{fe} + P_{cu}$ (milliwatts), is in the form of heat and is dissipated from exposed surfaces of a wound core.

The heat dissipated depends on the total exposed surface of the wound unit. Temperature rise cannot be predicted precisely, but can be approximated by the following formula:

$$\text{Temperature Rise (}^\circ\text{C)} = \left[\frac{\text{Total Power Loss (milliwatts)}}{\text{Surface Area (cm}^2\text{)}} \right]^{.833}$$

In this catalog, surface area is presented in two ways:

1. Unwound core (after insulation is added)
2. Wound core, assuming 40% winding factor

Nominal DC Resistance

Nominal DC Resistance, in ohms/millihenry, is useful in calculating DC winding resistance (R_{dc}) for any value of inductance. The value of nominal DC Resistance is essentially independent of wire size and the number of turns of wire. The value of Nominal DC Resistance for any given winding factor can be computed as follows:

$$\Omega/mh_{wf} = \frac{\Omega/mh_u}{wf} \times \frac{K_{wf}}{K_u}$$

where : Ω/mh_{wf} = Ω/mh for chosen winding factor
 Ω/mh_u = unity value, listed for each core size
 wf = chosen winding factor
 K_{wf} = length/turn for chosen wf*
 K_u = length/turn for unity (100%) wf*
 *see "Winding Turn Length" on core size pages

The value of R_{dc} for any given winding factor can be computed as follows:

$$R_{dcwf} = R_{dcu} \times wf \times \frac{K_{wf}}{K_u}$$

where : R_{dcwf} = R_{dc} for chosen winding factor
 R_{dcu} = unity value, listed for each size (ohms)
 wf = chosen winding factor
 K_{wf} = length/turn for chosen wf*
 K_u = length/turn for unity (100%) wf*

Sample Calculation

Using a 55930 core, we can calculate the value of R_{dc} for 50 mh and 40% winding factors as follows, using parameter values listed on page 4-19:

$$\Omega/mh_{40\%} = \frac{\Omega/mh_u}{wf} \times \frac{K_{40\%}}{K_u} = \frac{.0524}{.40} \times \frac{.1344}{.1714} = .103 \Omega/mh$$

The value of ohms/mh yields a value of R_{dc} at 50 mh, of 5.1 ohms (50mh x .103)

The value R_{dc} for the 55930 core can also be obtained by noting the unity values for No. 28 wire (i.e. 1400 turns and 15.67 ohms) can be converted to 40% winding factor values as follows:

$$\begin{aligned} N_{40\%} &= N_{unity} \times wf \\ &= 1400 \times .40 \\ &= 560 \text{ turns} \end{aligned}$$

$$\begin{aligned} R_{dc40\%} &= R_{dcu} \times wf \times \frac{K_{40\%}}{K_u} \\ &= 15.67 \times .40 \times \frac{.1344}{.1714} \\ &= 4.9 \text{ ohms} \end{aligned}$$

Core Selection Procedure

Only two parameters of the design application must be known: inductance required with dc bias and the dc current. Use the following procedure to determine the core size and number of turns.

1. Compute the product of LI^2 where:
 L = inductance required with dc bias (millihenrys)
 I = dc current (amperes)
2. Locate the LI^2 value on the Core Selector Chart (page 2-3 & 2-4). Follow this coordinate to the intersection with the first core size that lies above the diagonal permeability line. (Small core sizes are at the bottom; large core sizes are at the top.) This is the smallest core size that can be used.
3. The permeability line is sectioned into standard available core permeabilities. Selecting the permeability indicated will yield the smallest core that can be used. Lower or higher permeabilities can be used, but the resulting core size will be larger.
4. Inductance, core size, and permeability are now known. Calculate the number of turns by using the following procedure:
 - (a) The nominal inductance (A_L in mH / 1000 turns) for the core is obtained from the core data sheet. Determine the minimum nominal inductance by using the worst case negative tolerance (-8%, -12%, or -15%, depending on the core size). With this information, calculate the number of turns needed to obtain the required inductance (see A_L and Inductance Considerations, page 1-5).
 - (b) Calculate the bias in oersteds from:
 $H = 0.4\pi NI/le$
 - (c) From the Permeability vs. DC Bias curves (page 3-15, 3-16, 4-33, & 4-35), determine the rolloff in per unit of initial permeability (μ_{pu}) for the previously calculated bias level.
 - (d) Increase the number of turns by dividing the initial number of turns (from step 4a) by the per unit value of initial permeability. This will yield an inductance close to the required value. A final adjustment of turns may be necessary if a specific inductance is required.
5. Choose the correct wire size using the Wire Table (page 3-21). Duty cycles below 100% allow smaller wire sizes and lower winding factors, but do not allow smaller core sizes.
6. The core chosen will have an inductance equal to or greater than that required when biased with the specified dc current. The resulting winding factor will be between 25% and 45%.

Core Selection Example and Analysis

Choose a core with the following requirements:

- (a) minimum inductance with dc bias of 1.0 mH
- (b) dc current of 3.0 amperes

1. The product of $LI^2 = 1.0 \times 3.0^2 = 9.00$
2. This coordinate passes through the 60μ section of the permeability line and, proceeding upwards, intersects the horizontal 55586 core line. The part number for a 60μ core of this size is 55586.
3. The 55586 core data sheet shows the nominal inductance of this core to be 38 mH / 1000 turns, $\pm 8\%$. Therefore, the minimum inductance of this core is 34.96 mH / 1000 turns.
4. The number of turns needed to obtain 1.0 mH is 169.1 turns. The magnetizing force (dc bias) is 71.2 oersteds, yielding 68% of initial permeability. The adjusted turns are 249.
5. The wire table indicates that #20 wire is needed for 3.0 amperes. Therefore, a 55586 core with 249 turns of #20 wire will meet the requirements.

An analysis of the preceding result yields the following:

1. Calculate the dc bias level in oersteds:
 $H = 0.4\pi NI/le = 104.9$ oersteds
2. The permeability versus DC Bias curve shows a 48% initial permeability at 104.9 oersteds for 60μ material.
3. Multiply the minimum A_L 34.96 mH by 0.48 yields 16.78 mH.
4. The inductance of this core with 249 turns and with 104.9 oersteds of dc bias will be 1.04 mH. The minimum inductance requirement of 1.0 mH has been achieved with the dc bias.
5. 249 turns of #20 wire (0.00634 cm^2) equals 1.579 cm^2 , which is 39% winding factor on this core (total window area of 4.01 cm^2).

Core Selector Charts

The core selector charts will quickly yield optimum permeability and smallest core size for dc bias applications. These charts are based on a permeability reduction of not more than 50% with dc bias, typical winding factors of 25% to 40%, and an ac current, which is small relative to the dc current. These charts are based on the minimum inductance tolerance of the chosen core size and permeability.

If a core is being chosen for use with a large ac current relative to any dc current, such as a flyback inductor or

buck/boost inductor, select a core that is one or two sizes larger than indicated by the selector charts. This will assist in reducing the operating flux density of the ac current that generates core loss.

For additional power handling capability, LI^2 , multiple stacking of cores will yield an equivalent multiple power handling for a given core size. For example, double stacking of the 55908 core will result in a doubling of its power handling capability to about 1000 mH-amperes².

MPP Core Selector Chart

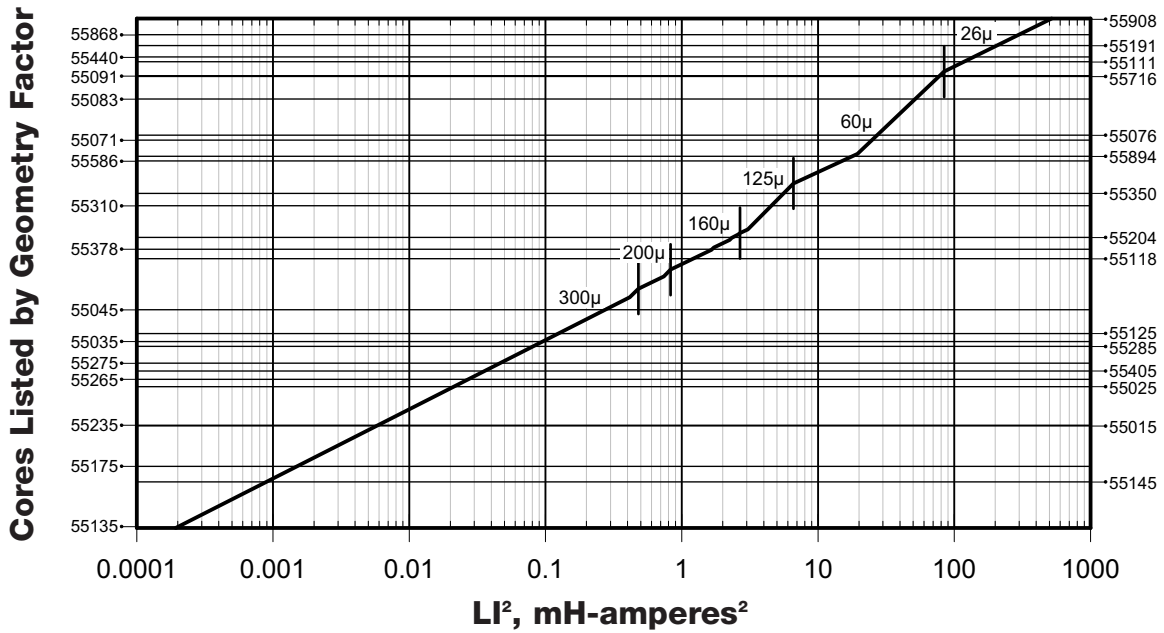

High Flux Core Selector Chart

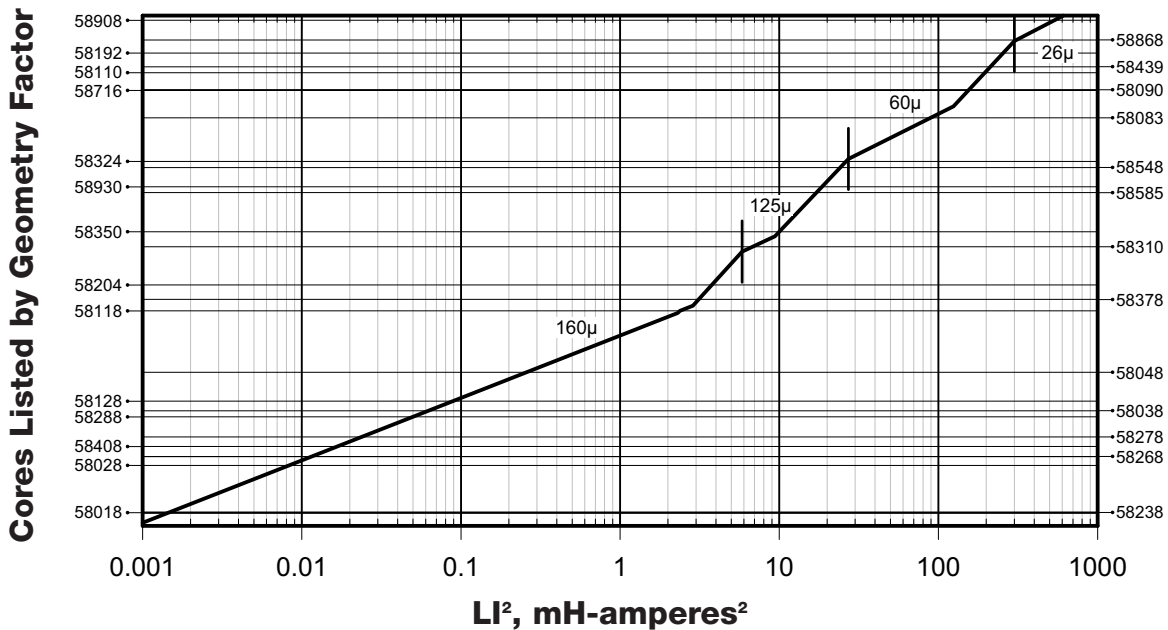

Kool M μ [®] Core Selector Chart

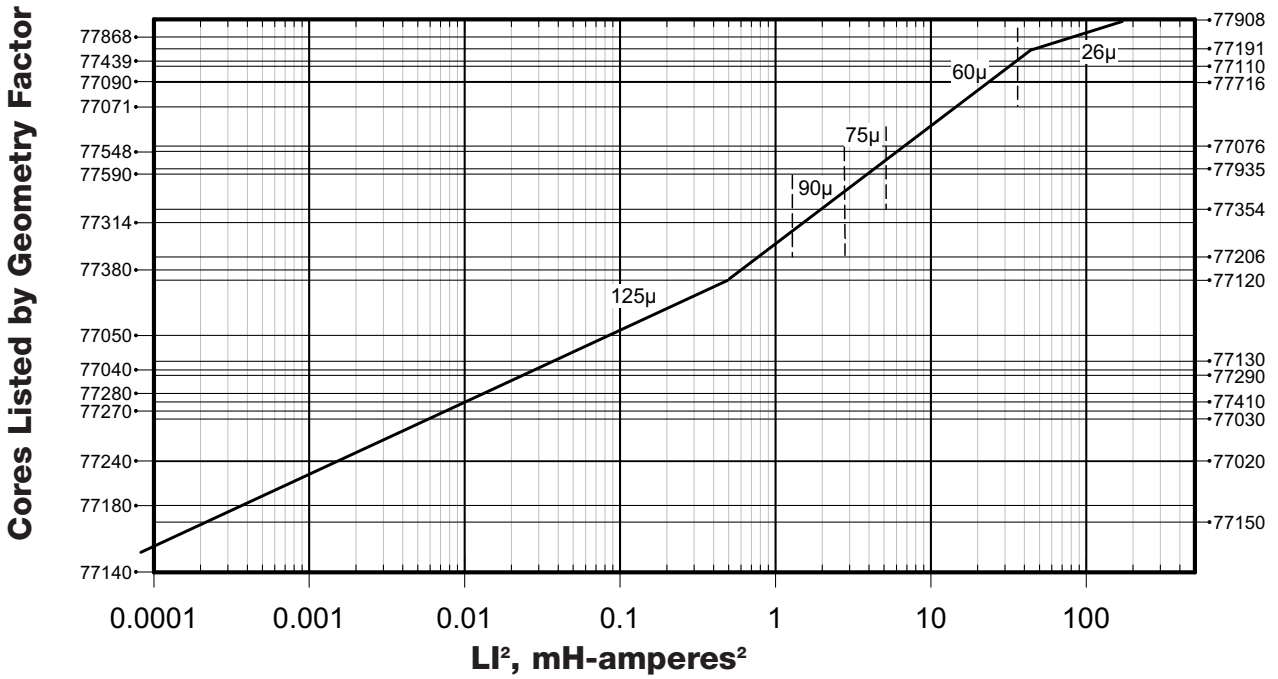

Core Selection

Kool M μ [®] E Core Selector Chart

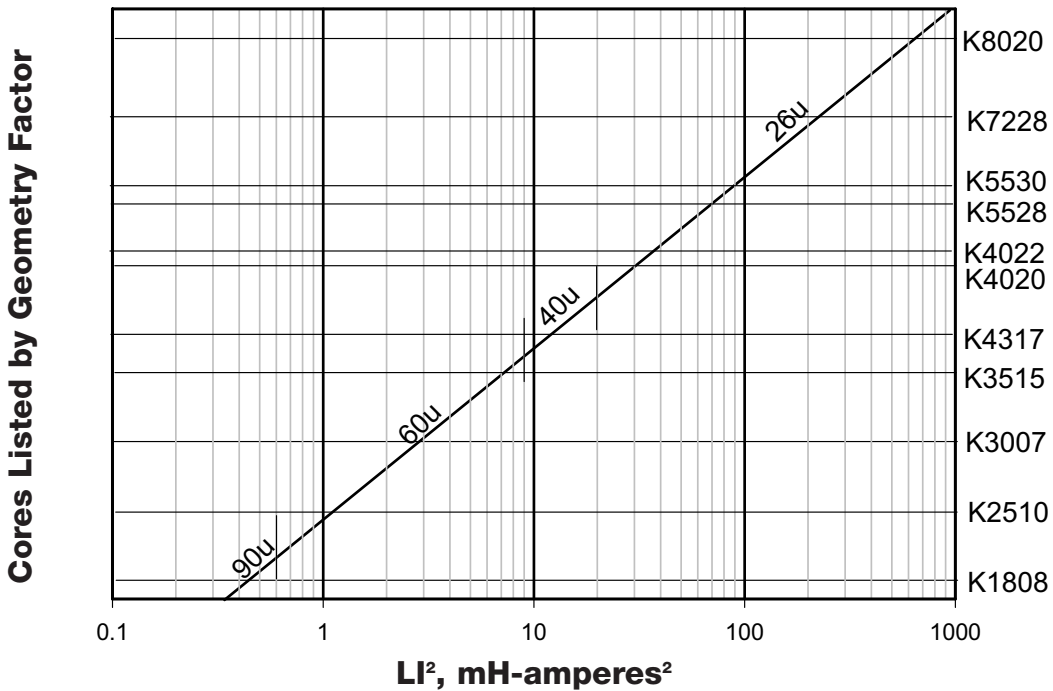

Material Properties

	PERMEABILITY VS. T, B, & F - TYPICAL			
	Permeability (μ)	μ vs. T dynamic range (-50° C to +100° C) Painted cores usable to 200° C	μ vs. B dynamic range 50 to 4000gauss (peak at 1000 gauss)	μ vs. F. flat to...
MPP	14 μ	0.6%	+0.4%	9 MHz
	26 μ	0.6%	+0.4%	5 MHz
	60 μ	0.6%	+0.8%	2.7 MHz
	125 μ	0.6%	+1.4%	1 MHz
	160 μ	0.6%	+1.9%	700 kHz
	200 μ	0.6%	+2.5%	500 kHz
	300 μ	0.6%	+4.0%	150 kHz
	550 μ	7.0%	+20.0%	90 kHz
High Flux	14 μ	0.8%	+5.0%	8 MHz
	26 μ	1.0%	+9.0%	2.5 MHz
	60 μ	1.4%	+13.5%	1.2 MHz
	125 μ	1.8%	+19.0%	600 kHz
	160 μ	2.8%	+25.5%	350 kHz
Kool Mμ	26 μ	4.0%	+1.0%	20 MHz
	60 μ	8.0%	+1.5%	8 MHz
	75 μ	10.0%	+2.0%	3 MHz
	90 μ	12.0%	+3.0%	2 MHz
	125 μ	15.0%	+3.5%	1 MHz

Material properties above only apply to toroids, not THINZ or E cores.

	Curie Temperature	Density	Coefficient of Thermal Expansion	Thermal Conductivity
MPP	460° C	8.7 grams/cm ³	12.9 x 10 ⁻⁶ /°C	0.8 Watts/(cm x °K)
High Flux	500° C	8.2 grams/cm ³	5.8 x 10 ⁻⁶ /°C	0.8 Watts/(cm x °K)
Kool M μ	500° C	7.0 grams/cm ³	10.8 x 10 ⁻⁶ /°C	0.8 Watts/(cm x °K)

Conversion Tables

	Multiply number of	by	to obtain number of
MPP, High Flux, Kool M μ	oersteds	.795	amp-turns / cm
MPP, High Flux, Kool M μ	gauss	.0001	tesla
MPP, High Flux, Kool M μ	in ²	6.425	cm ²
MPP, High Flux, Kool M μ	circular mils	5.07 x 10 ⁻⁶	cm ²
MPP	watts / lb.	19.17	mWatts / cm ³
High Flux	watts / lb.	18.07	mWatts / cm ³
Kool M μ	watts / lb.	15.42	mWatts / cm ³

Core weights listed in this catalog are for 125 μ cores. To determine weights for other permeabilities, multiply the 125 μ weight by the following factors:

Permeability	14 μ	26 μ	60 μ	75 μ	90 μ	125 μ	160 μ	200 μ 300 μ	550 μ
x Factor	0.80	0.86	0.94	0.96	0.97	1.00	1.02	1.03	1.04

Normal Magnetization Curves, MPP

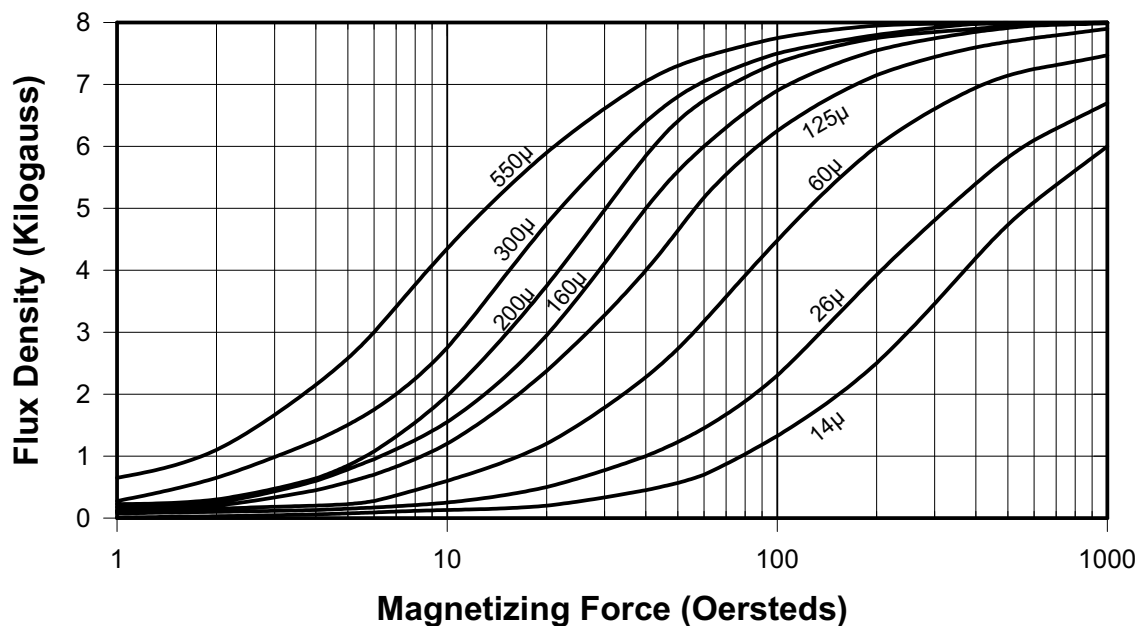

Normal Magnetization Curves, High Flux

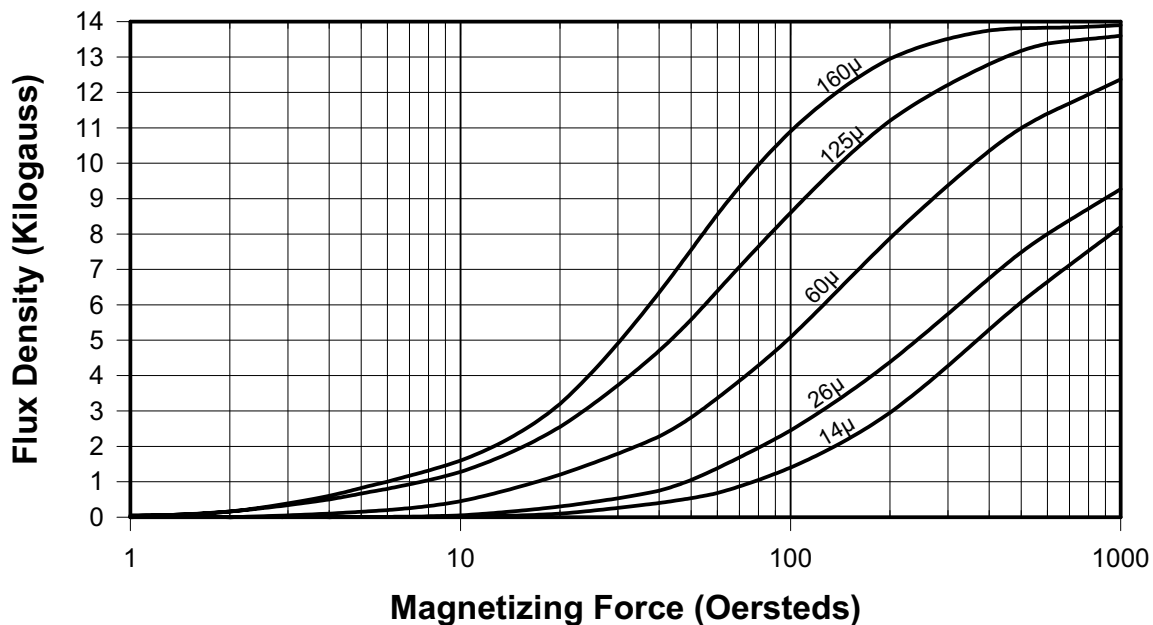

Normal Magnetization Curves, Kool M μ [®]

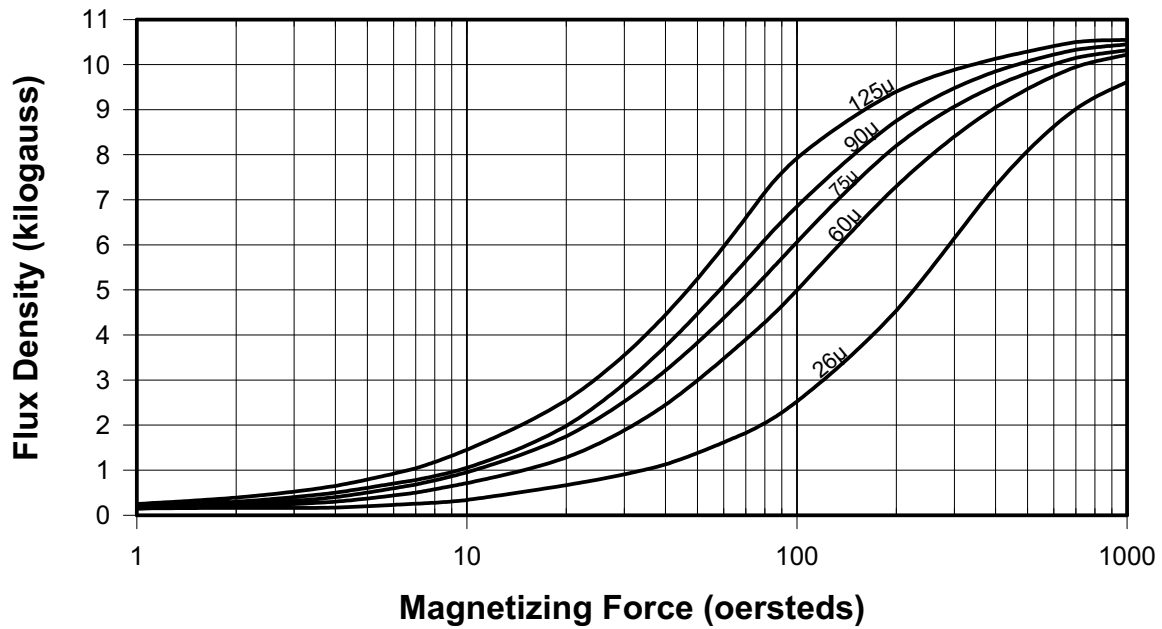

Normal Magnetization Curve Fit Formula

(refer to curves for units)

$$B = \left[\frac{a + bH + cH^2}{1 + dH + eH^2} \right]^x$$

where:

		a	b	c	d	e	x
MPP	14μ	-23.740	1.654E1	9.249E-1	6.189E1	3.158E-1	2
	26μ	0.2112	2.780E-2	-2.274E-5	8.849E-3	-7.810E-6	2
	60μ	0.2576	5.900E-2	1.208E-4	1.970E-2	4.780E-5	2
	125μ	0.0642	-4.990E-2	2.060E-2	7.879E-3	3.398E-4	0.5
	160μ	0.0447	-4.440E-2	3.300E-2	7.975E-3	5.170E-4	0.5
	200μ	0.1001	-1.154E-1	5.780E-2	4.820E-3	9.043E-4	0.5
	300μ	0.0940	-1.228E-1	1.260E-1	1.910E-2	1.946E-3	0.5
550μ	0.0730	-1.201E-1	4.105E-1	5.070E-2	6.290E-3	0.5	
High Flux	14μ	-1.880E-1	2.190E-2	7.255E-4	4.210E-2	2.200E-4	2
	26μ	-1.286E-1	4.120E-2	7.493E-4	4.230E-2	2.161E-4	2
	60μ	-5.360E-1	3.058E-1	2.430E-2	5.521E-1	6.434E-3	2
	125μ	5.320E-2	-5.420E-2	2.220E-2	8.372E-3	1.073E-4	0.5
	160μ	2.670E-2	-4.230E-2	2.980E-2	1.763E-3	1.556E-4	0.5
Kool Mμ	26μ	5.868E-3	7.450E-3	5.706E-4	-2.930E-4	5.539E-6	0.5
	60μ	1.658E-2	1.831E-3	4.621E-3	4.700E-3	3.833E-5	0.5
	75μ	1.433E-2	7.738E-3	8.376E-3	5.773E-3	7.159E-5	0.5
	90μ	5.660E-2	-9.675E-3	1.250E-2	5.792E-3	1.075E-4	0.5
	125μ	7.808E-3	4.049E-2	1.643E-2	3.121E-3	1.447E-4	0.5

Core Loss Density Curves, MPP 14 μ

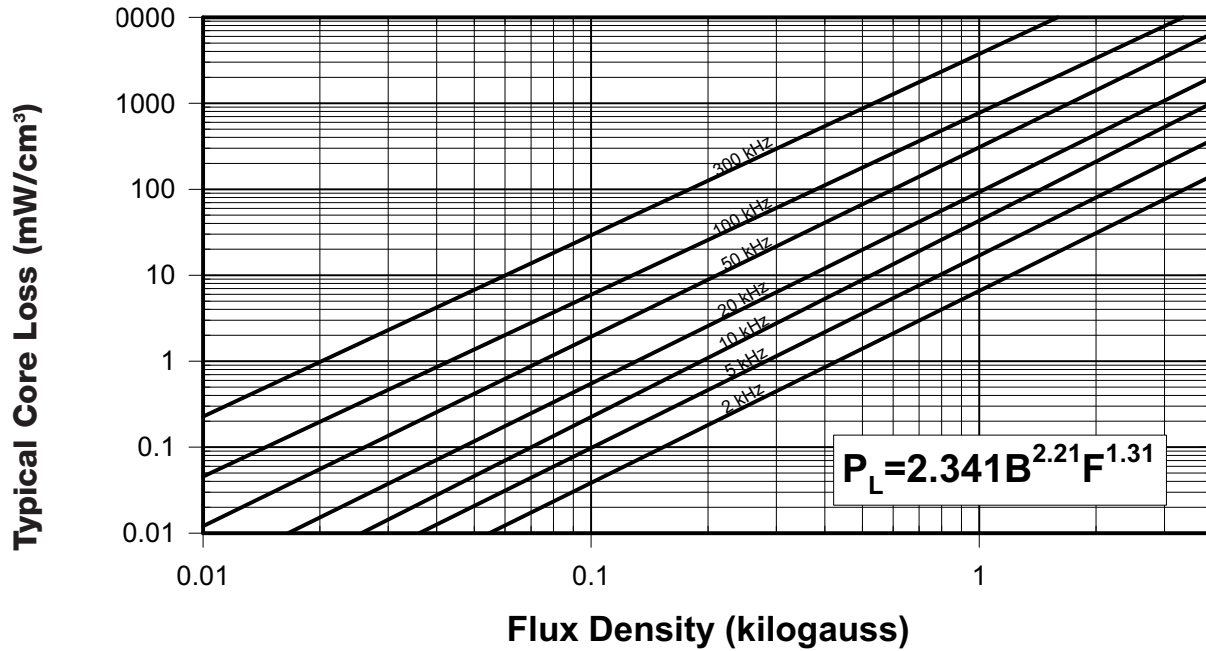

Core Loss Density Curves, High Flux 14 μ

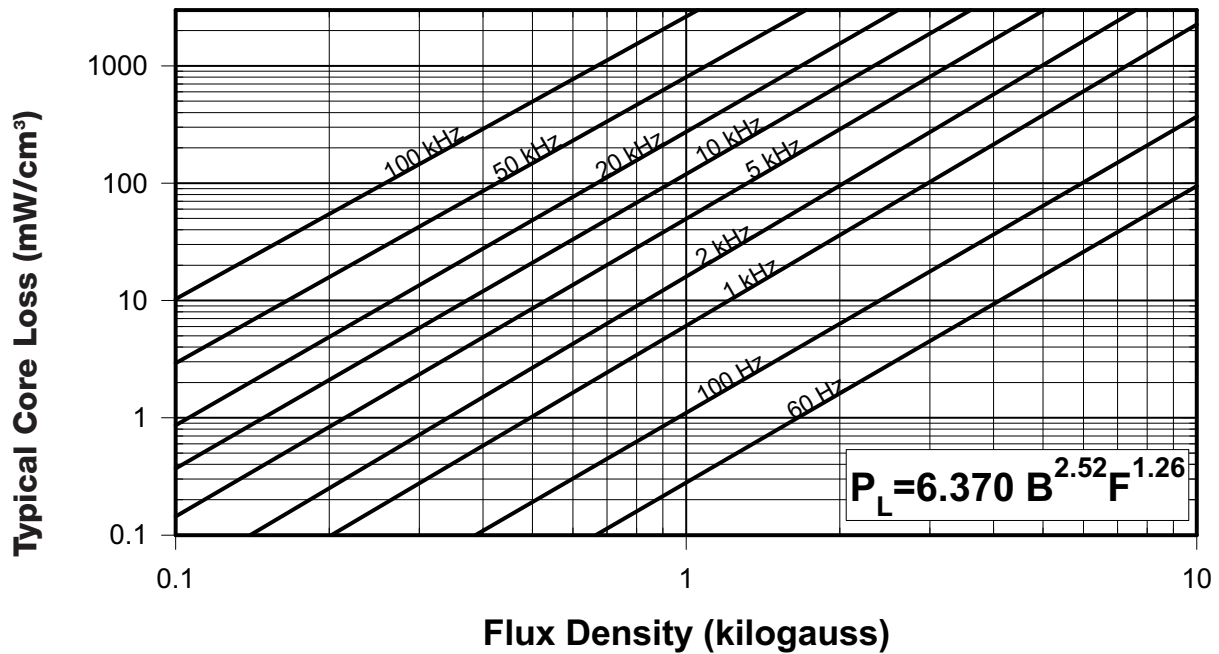

Core Loss Density Curves, MPP 26 μ

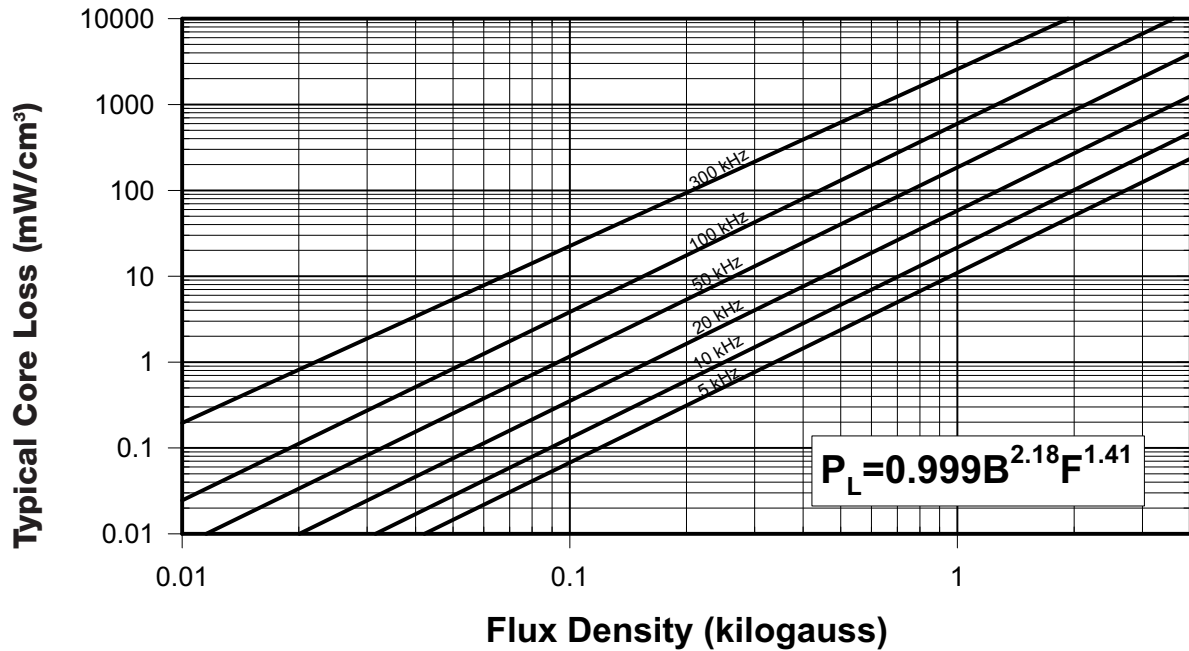

Core Loss Density Curves, High Flux 26 μ

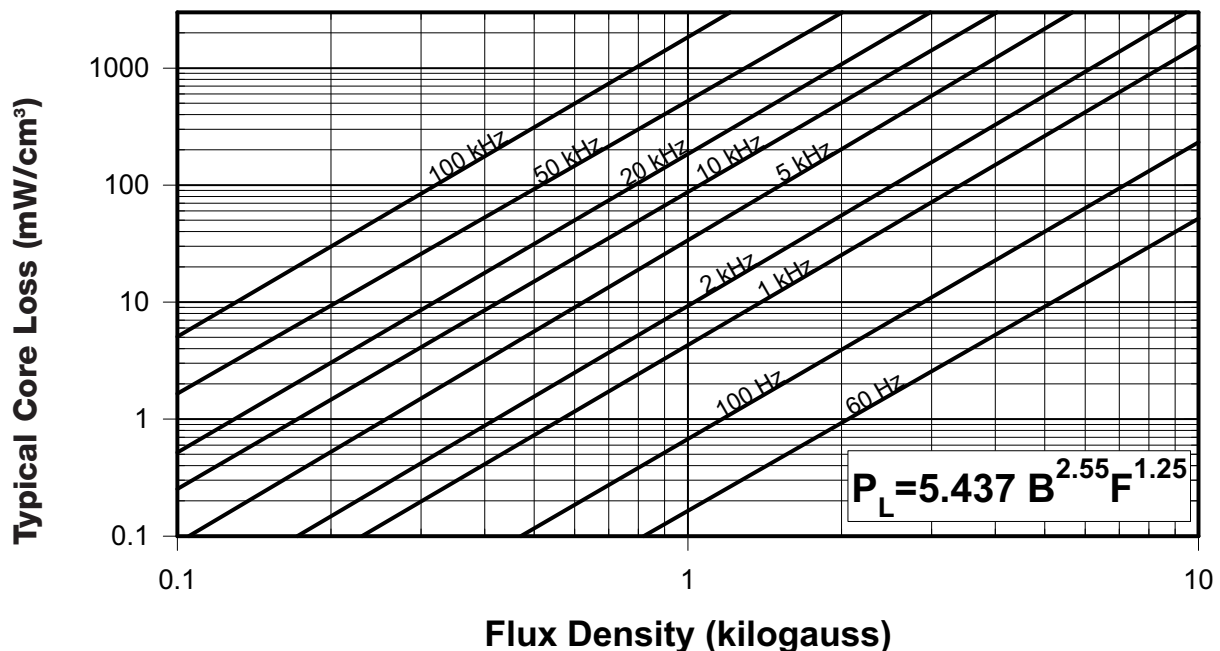

Core Loss Density Curves, MPP 60μ

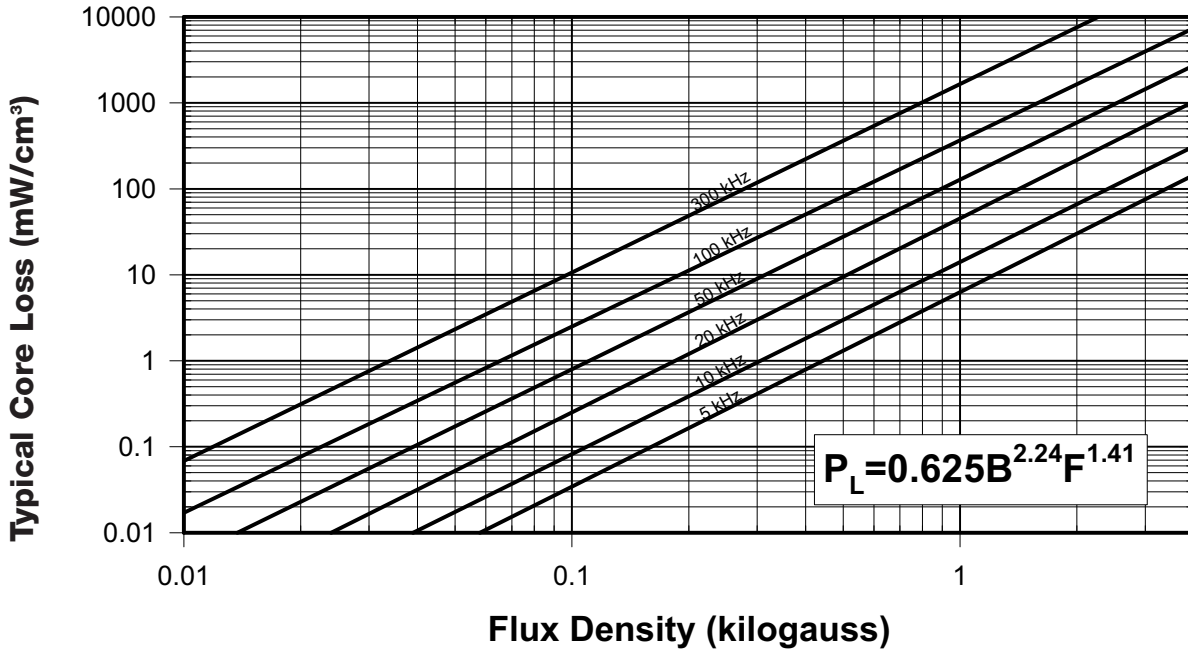

Core Loss Density Curves, High Flux 60μ

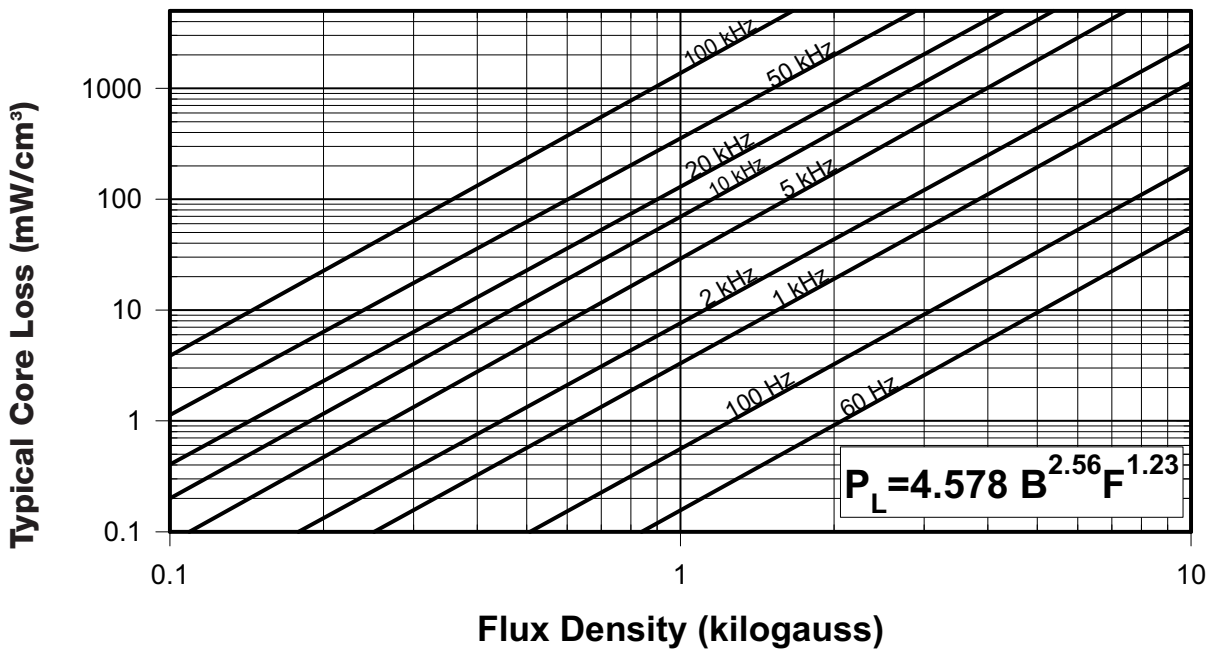

Core Loss Density Curves, MPP 125 μ

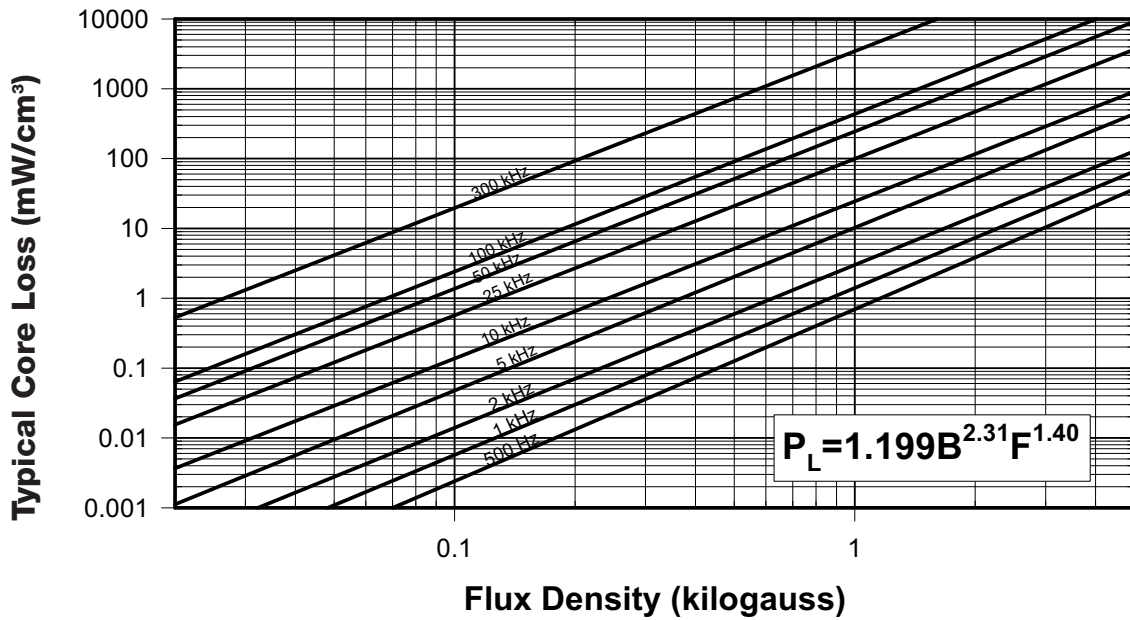

Core Loss Density Curves, High Flux 125 μ

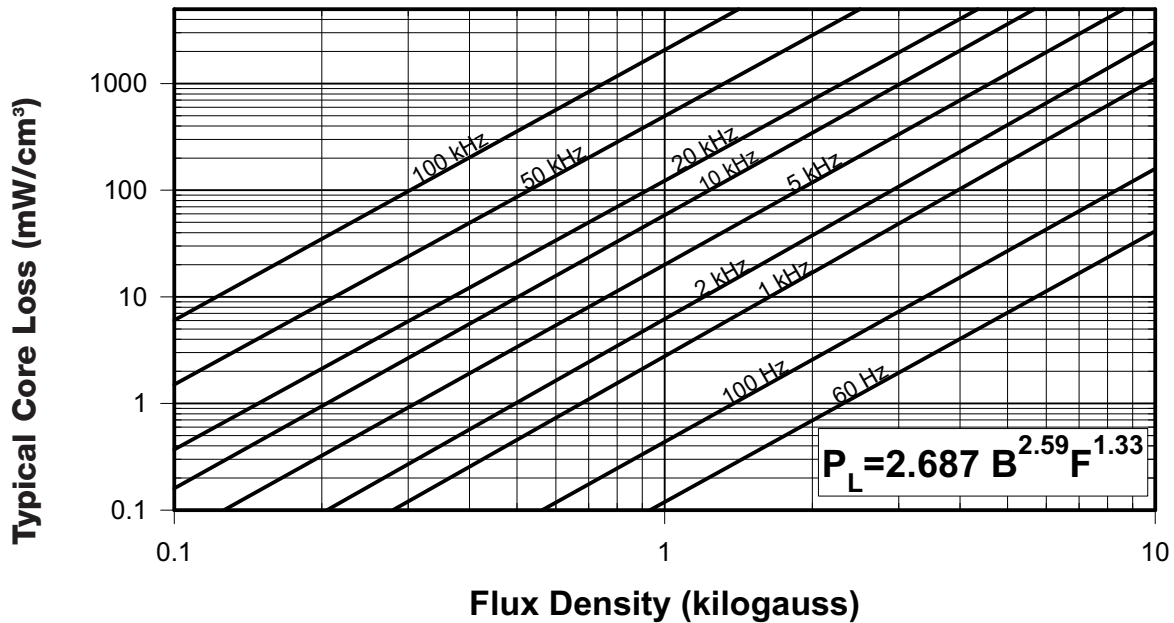

Core Loss Density Curves, MPP 160 μ

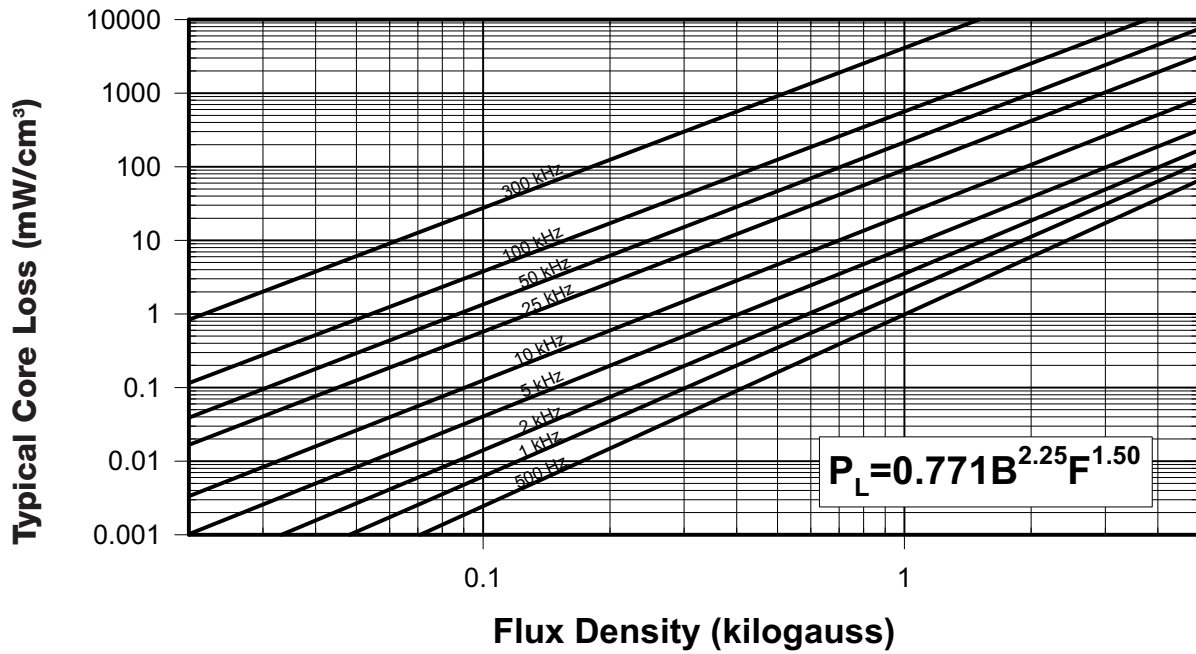

Core Loss Density Curves, High Flux 160 μ

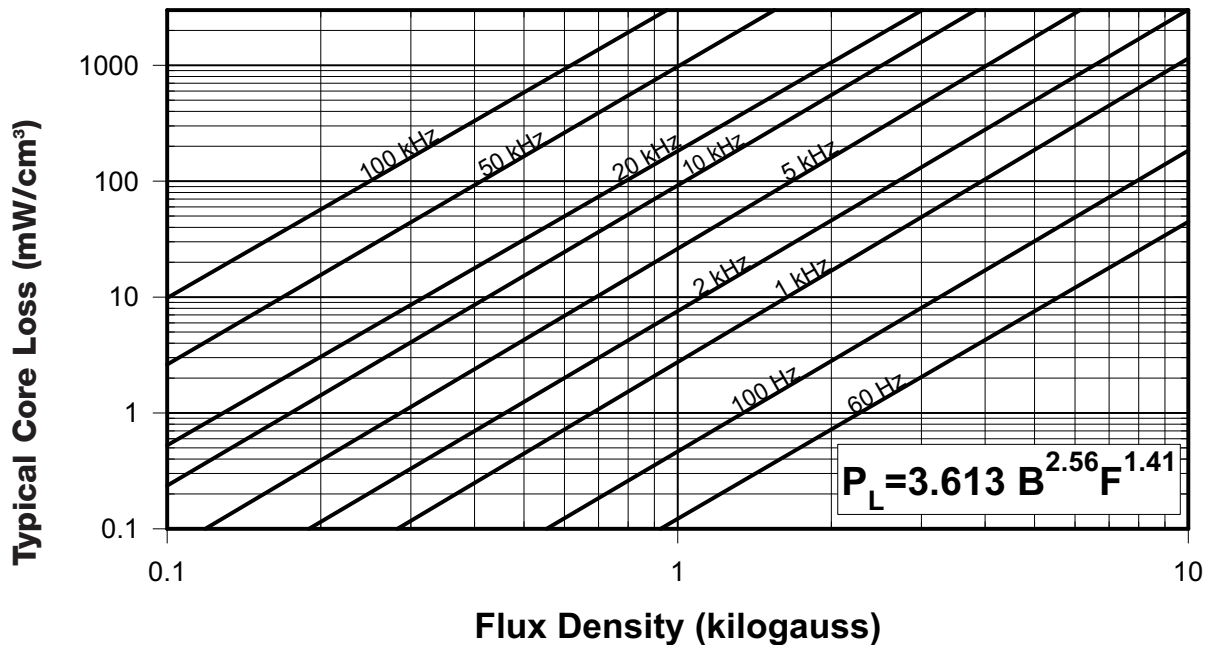

Core Loss Density Curves, MPP 200μ/300μ

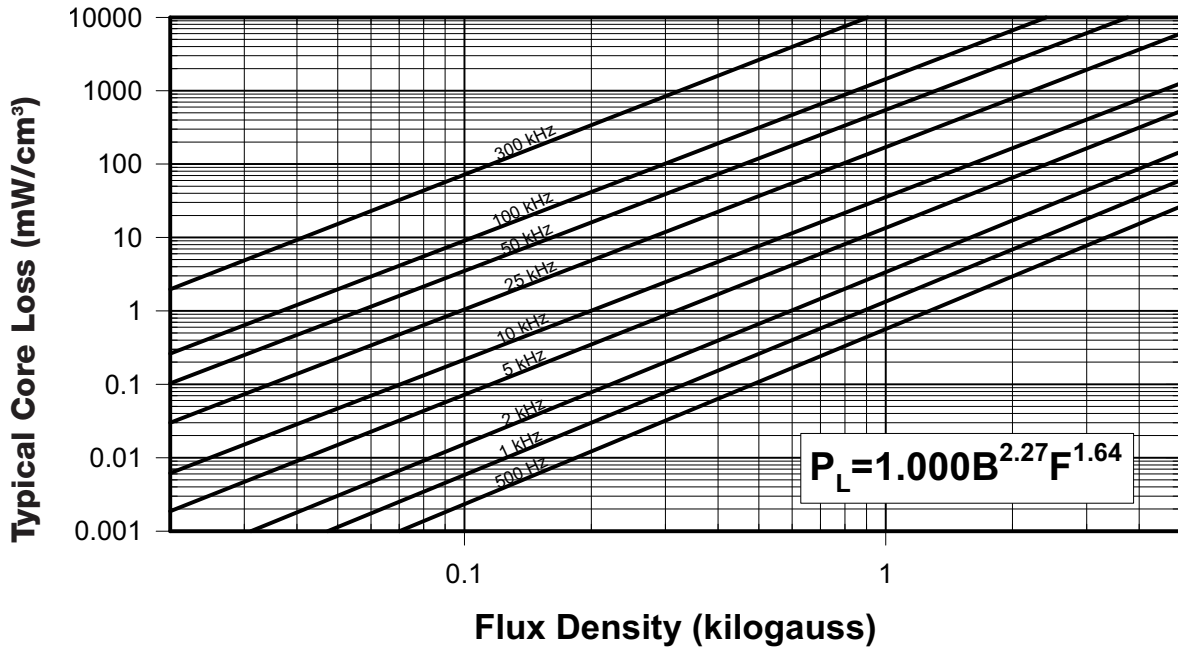

Core Loss Density Curves, MPP 550μ

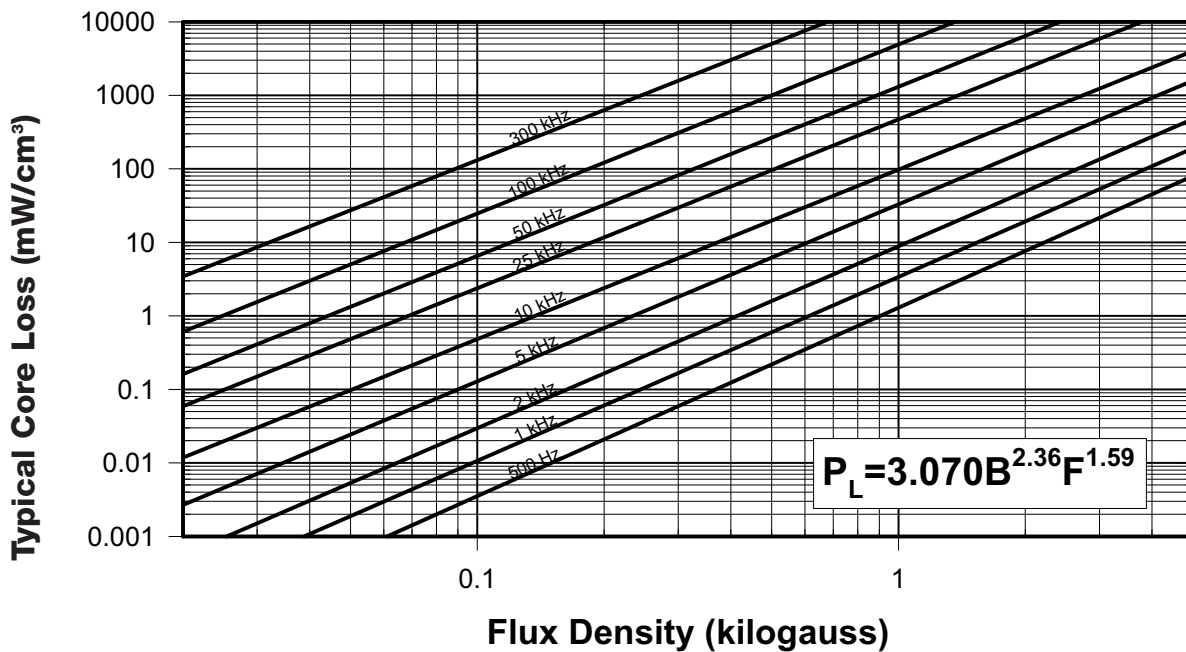

Core Loss Density Curves, Kool M μ [®] 26 μ

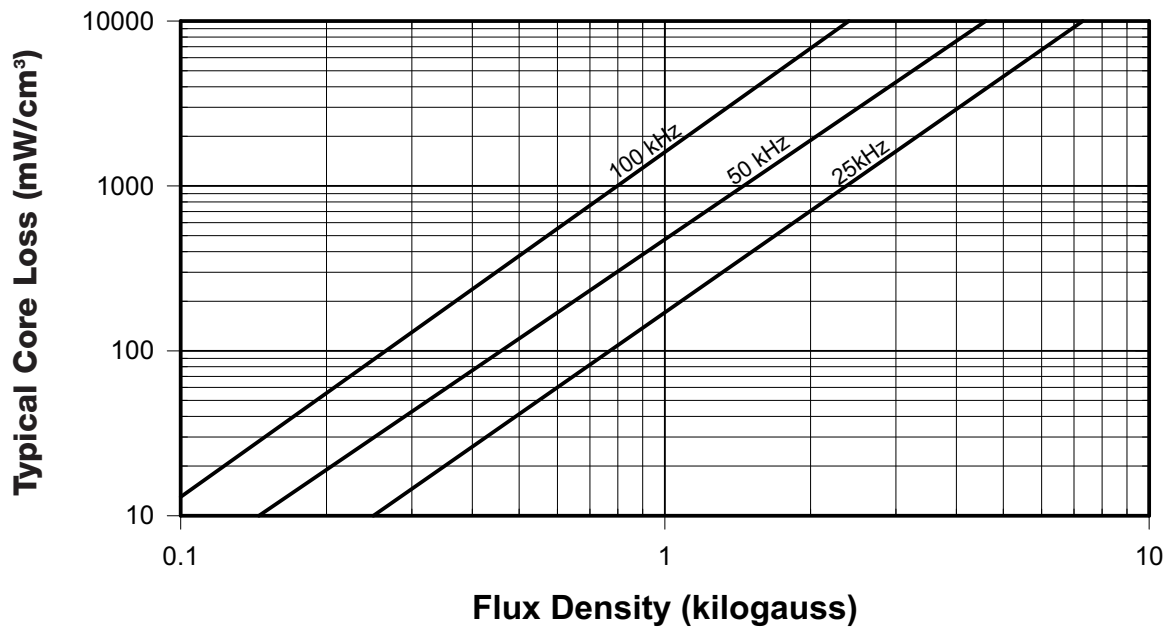

Core Loss Density Curves, Kool M μ [®] 60 μ - 125 μ

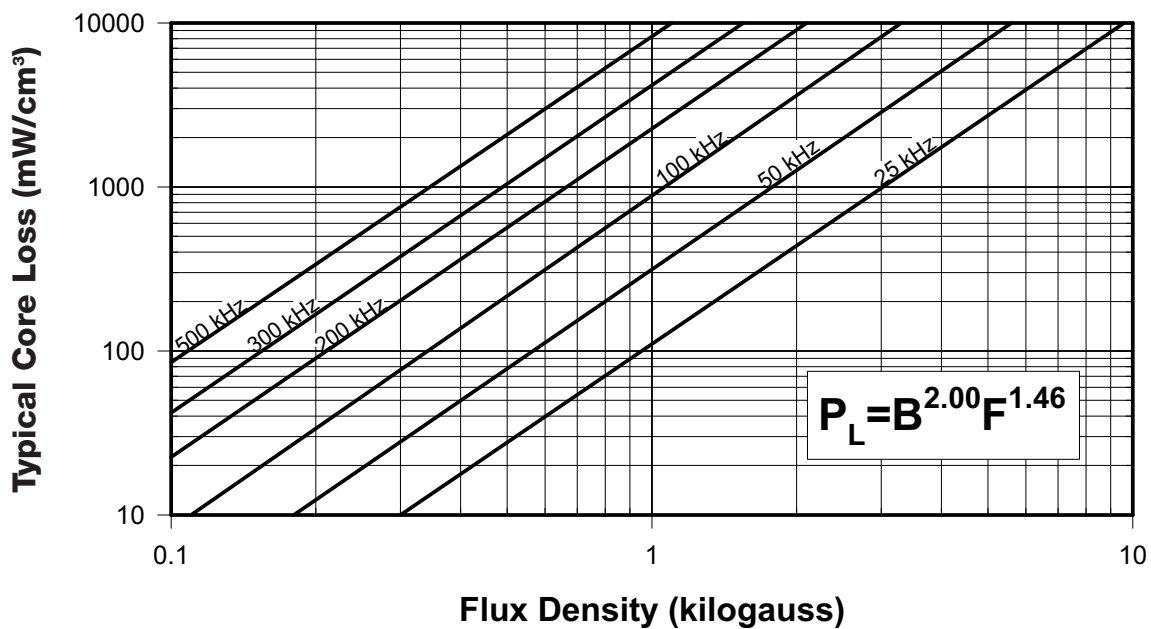

Permeability versus Temperature Curves, MPP (A2, AY, A5, A9)

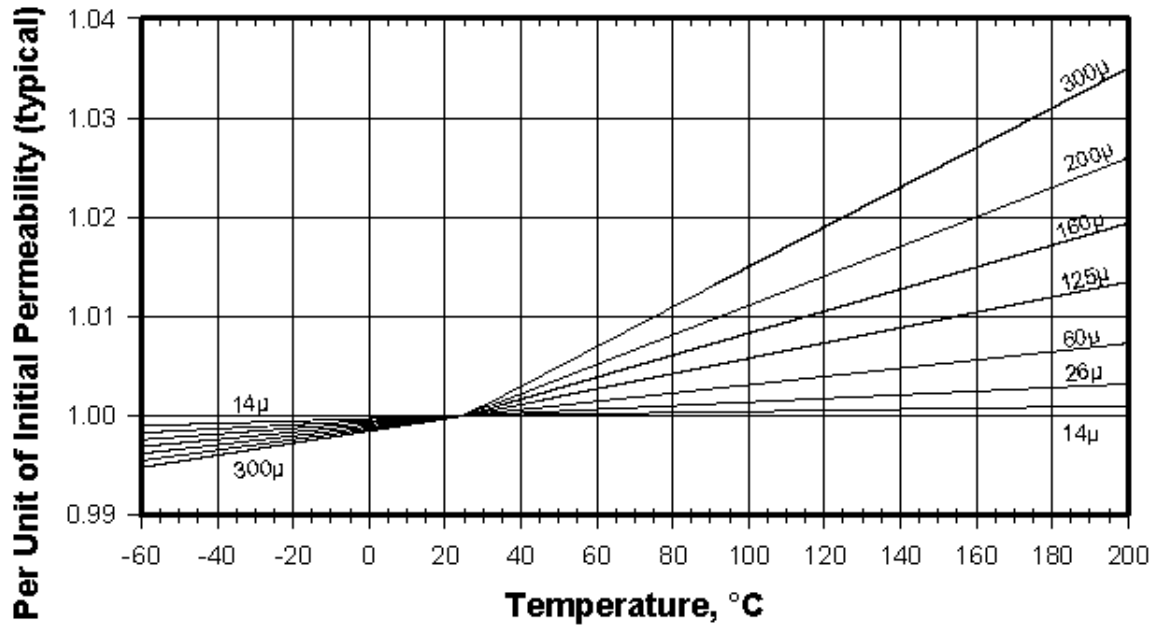

AY coating maximum steady-state operating temperature is 130° C.

Permeability versus Temperature Curves, MPP (A2, AY, A5, A9)

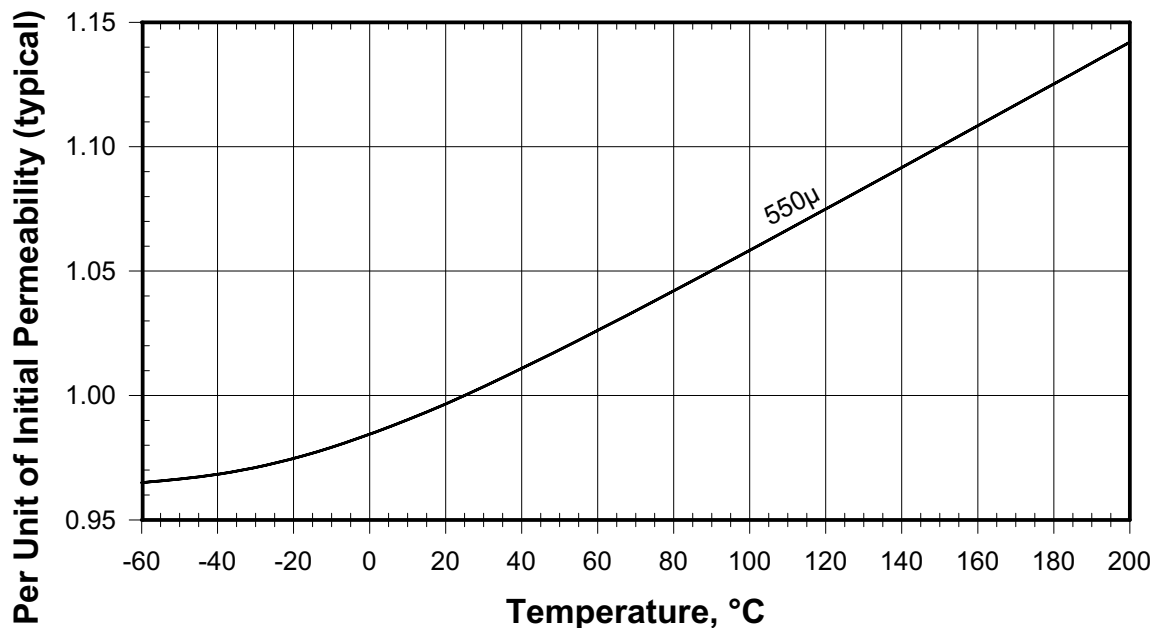

AY coating maximum steady-state operating temperature is 130° C.

Permeability versus Temperature Curves, High Flux

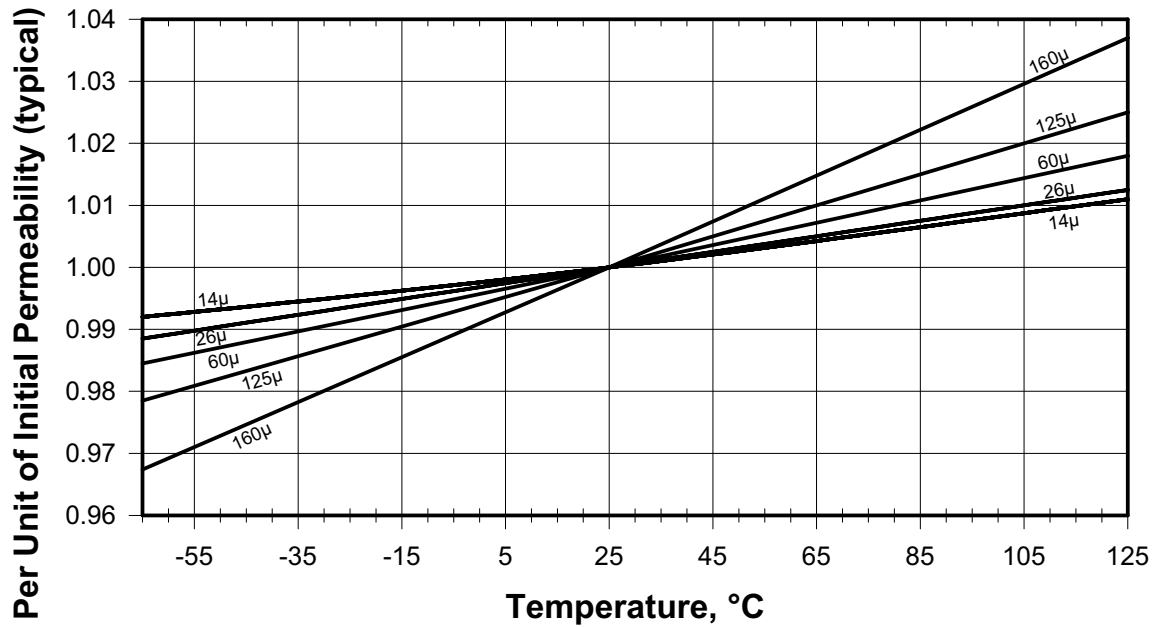

Permeability versus Temperature Curve Fit Formula (refer to curves for units)

$$\% \Delta \mu = a + bT + cT^2$$

where:

		a	b	c
High Flux	14μ	0.9975	9.667E-5	5.556E-8
	26μ	0.9967	1.293E-4	3.802E-8
	60μ	0.9956	1.739E-4	4.094E-8
	125μ	0.9940	2.402E-4	3.216E-8
	147μ	0.9921	3.140E-4	7.310E-8
	160μ	0.9908	3.674E-4	1.754E-8

Permeability versus Temperature Curves, Kool M μ

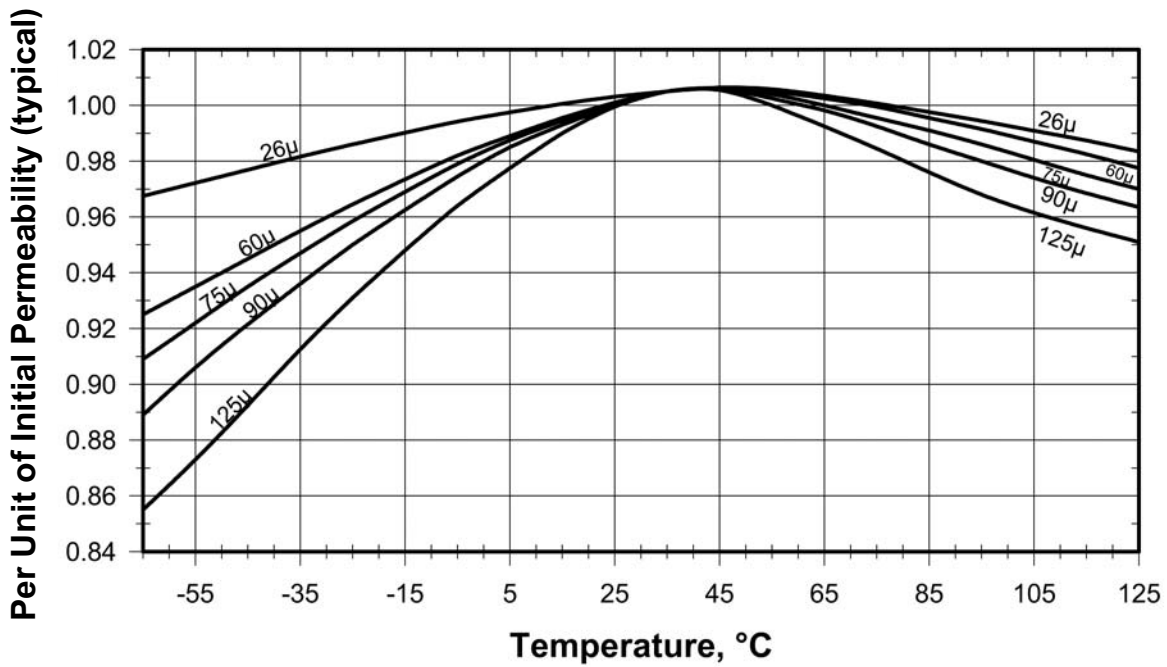

Permeability versus Temperature Curve Fit Formula (refer to curves for units)

$$\mu \text{ (per unit)} = a + bT + cT^2 + dT^3 + eT^4$$

where:

	a	b	c	d	e
Kool Mμ 26 μ	-0.3676	3.398E-2	-2.976E-4	-1.803E-6	1.079E-8
60 μ	-1.450	7.691E-2	-6.177E-4	-4.263E-6	3.108E-8
75 μ	-1.578	8.729E-2	-8.392E-4	-4.235E-6	3.749E-8
90 μ	-1.854	1.033E-1	-1.063E-3	-4.720E-6	4.539E-8
125 μ	-2.710	1.408E-1	-1.455E-3	-8.167E-6	7.764E-8

Permeability versus DC Bias Curves, MPP

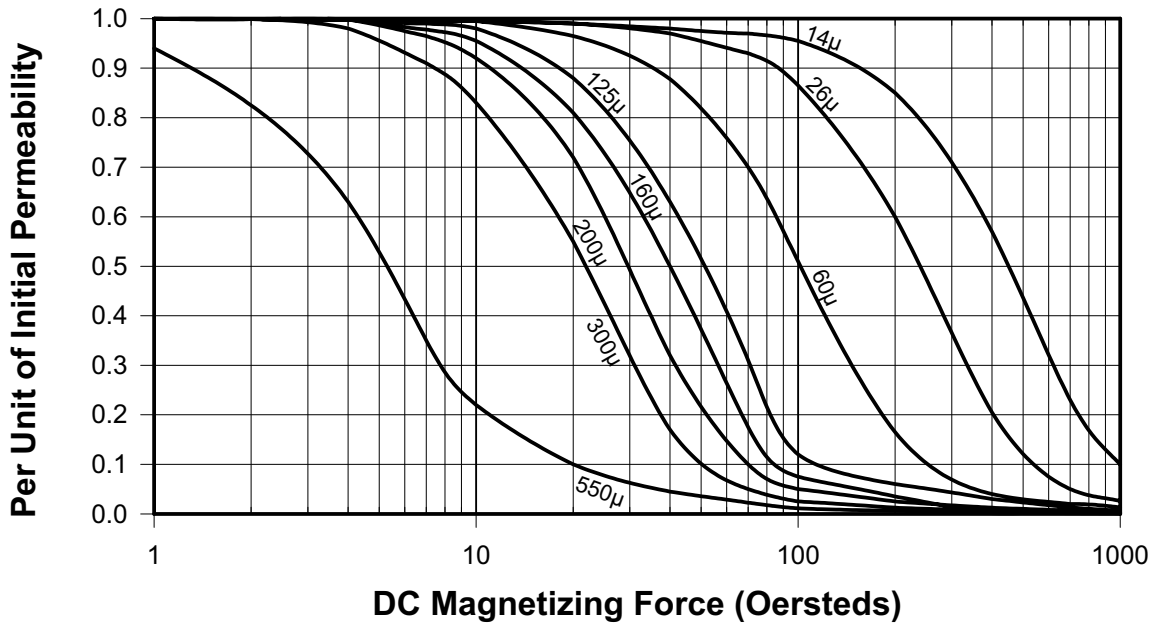

This curve only applies to MPP toroids. The MPP THINZ™ DC Bias curve can be found on page 4-35.

Permeability versus DC Bias Curves, High Flux

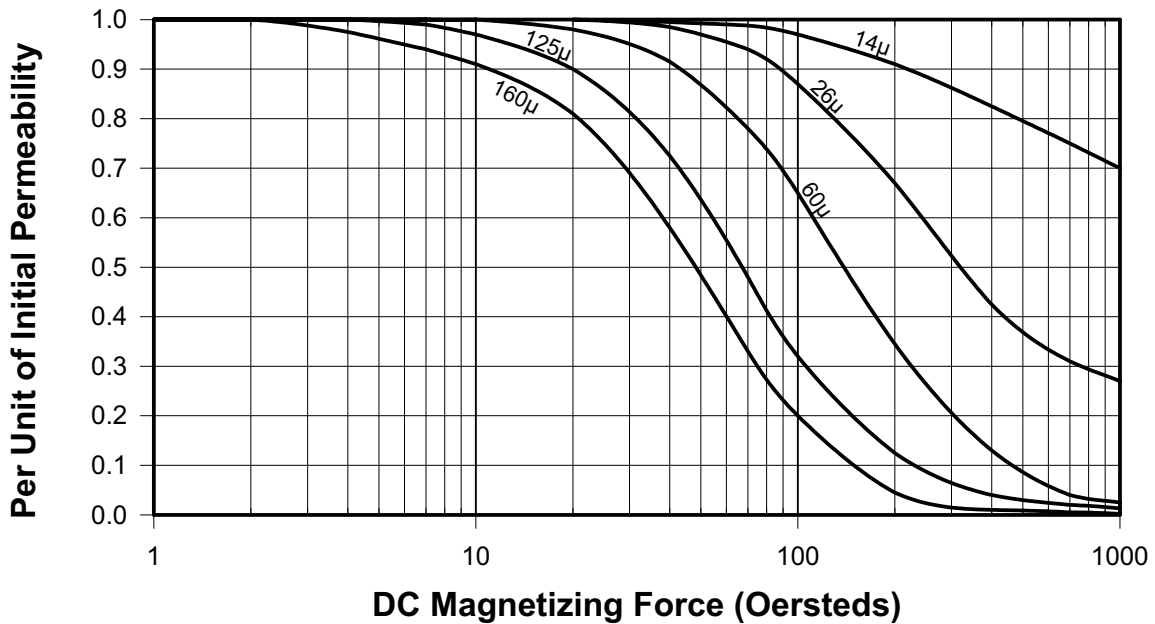

Permeability versus DC Bias Curves, Kool M μ [®]

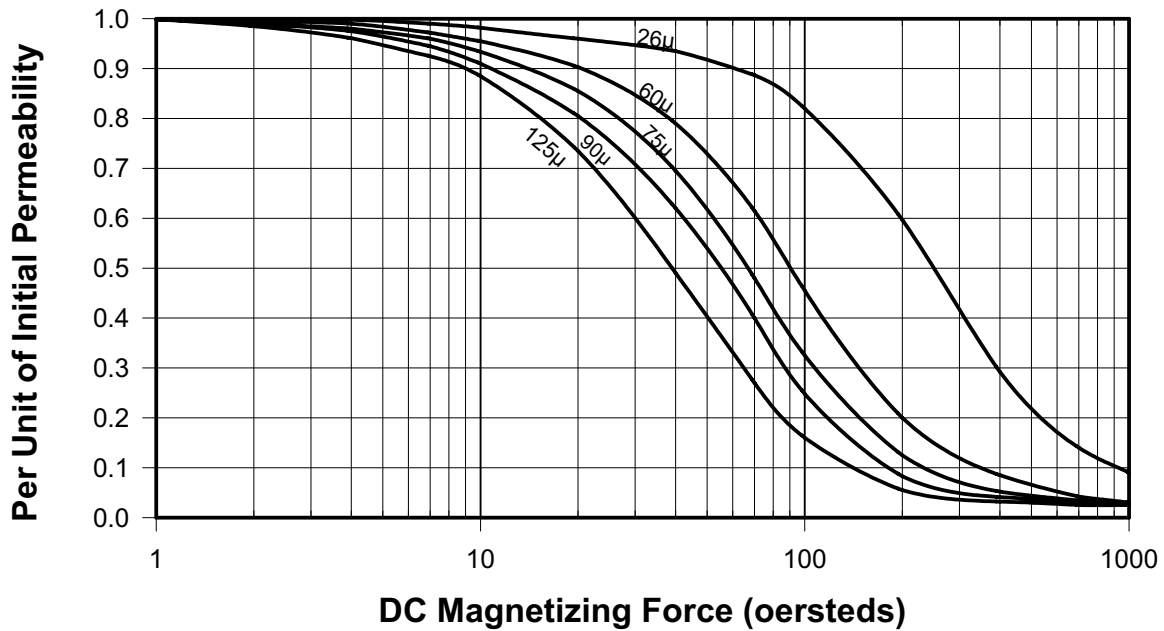

This curve only applies to Kool M μ toroids. The Kool M μ E core DC Bias curve can be found on page 4-33.

Permeability versus DC Bias Curve Fit Formula (refer to curves for units)

MPP*

$$\mu_{\text{eff}} = \sqrt{\frac{\mu_i^2 - 1.505 \times 10^{-4} \mu_i^3 H + 6.100 \times 10^{-9} \mu_i^4 H^2}{1 - 1.277 \times 10^{-4} \mu_i H + 2.740 \times 10^{-8} \mu_i^2 H^2}}$$

High Flux

$$\mu_{\text{eff}} = \sqrt{\frac{\mu_i^2 - 6.300 \times 10^{-5} \mu_i^3 H + 1.069 \times 10^{-9} \mu_i^4 H^2}{1 - 4.345 \times 10^{-6} \mu_i H + 1.922 \times 10^{-8} \mu_i^2 H^2}}$$

Kool M μ

$$\mu_{\text{eff}} = \sqrt{\frac{\mu_i^2 - 5.618 \times 10^{-5} \mu_i^3 H + 1.043 \times 10^{-10} \mu_i^4 H^2}{1 + 6.742 \times 10^{-5} \mu_i H + 6.210 \times 10^{-8} \mu_i^2 H^2}}$$

* The MPP Curve Fit formula is for permeability 14 - 300.

Permeability versus AC Flux Curves, MPP

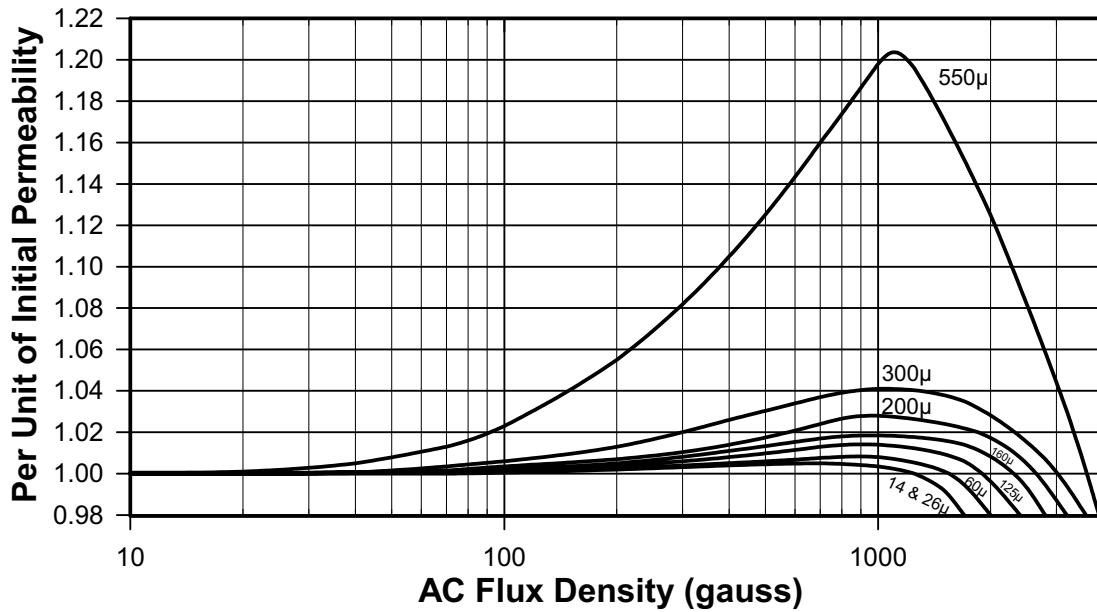

Permeability versus AC Flux Curves, High Flux

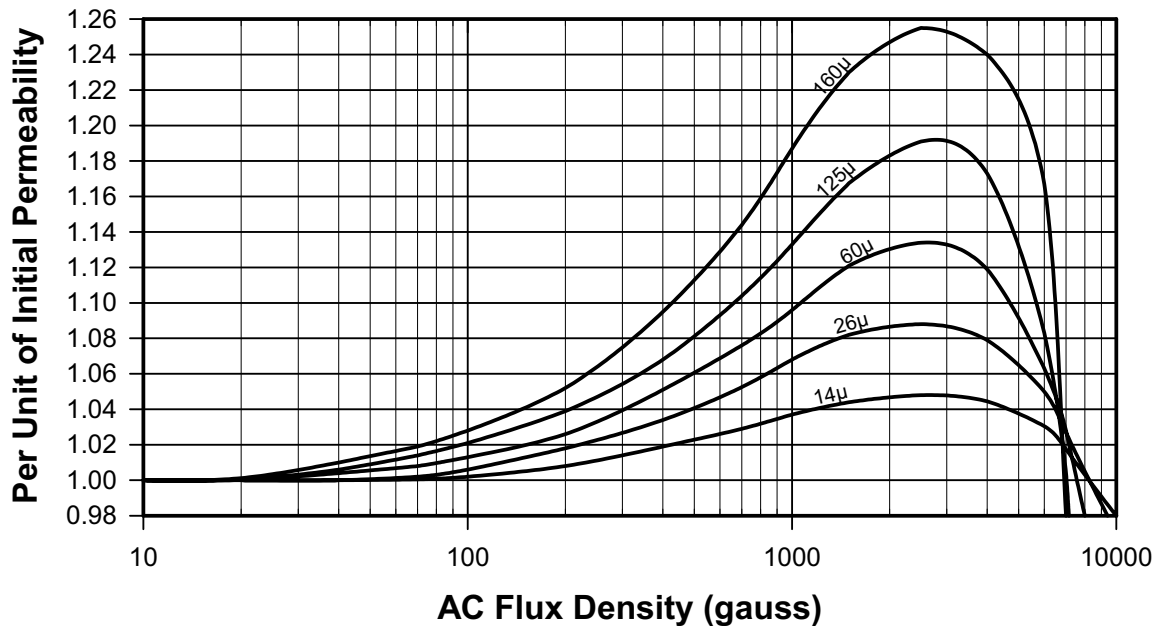

Permeability versus AC Flux Curves, Kool M μ [®]

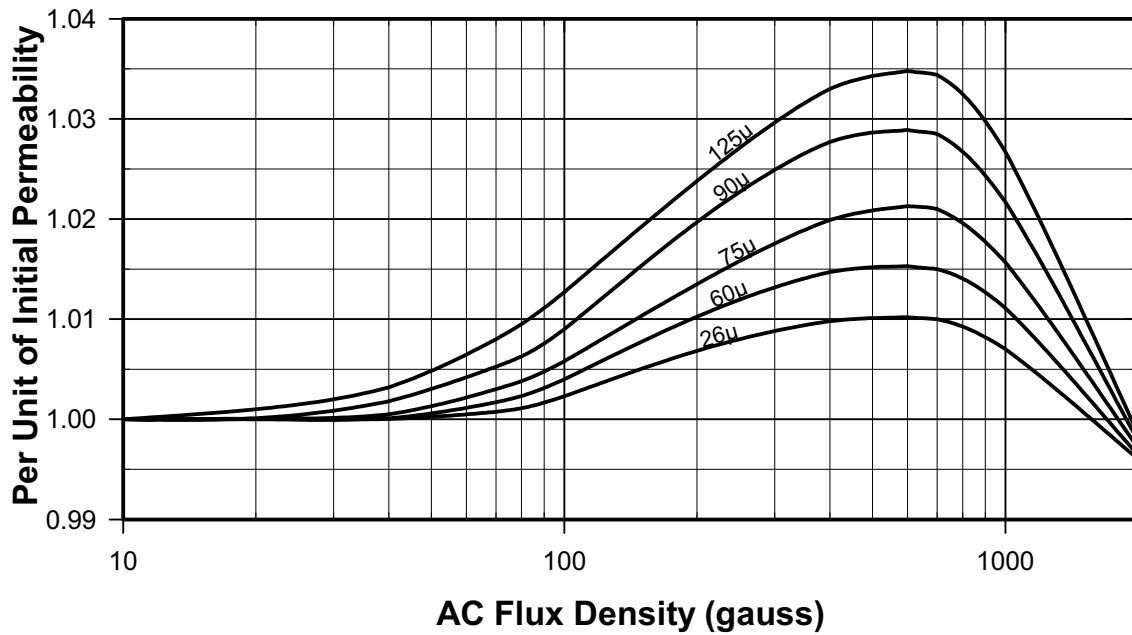

Permeability versus AC Flux Curve Fit Formula

(refer to curves for units)

MPP and High Flux

$$\mu_{\text{eff}}/\mu_i = (a + bB + cB^2 + dB^3 + eB^4)$$

where:

Kool M μ

$$\mu_{\text{eff}}/\mu_i = 1 + (a + bB + cB^2 + dB^3 + eB^4)$$

		a	b	c	d	e
MPP	14 μ	0.9995	1.186E-5	-5.096E-9	-2.727E-12	
	26 μ	0.9995	1.186E-5	-5.096E-9	-2.727E-12	
	60 μ	0.9990	1.708E-5	-6.675E-9	-1.792E-12	
	125 μ	0.9990	2.960E-5	-1.561E-8	8.254E-13	
	160 μ	0.9980	4.393E-5	-2.591E-8	3.446E-12	
	200 μ	0.9990	5.145E-5	-2.688E-8	3.308E-12	
	300 μ	0.9980	9.038E-5	-5.112E-8	7.055E-12	
	550 μ	0.9910	4.042E-4	-2.240E-7	3.123E-11	
High Flux	14 μ	0.999	5.458E-5	-1.930E-8	2.598E-12	-1.228E-16
	26 μ	0.998	1.020E-4	-3.696E-8	5.099E-12	-2.529E-16
	60 μ	1.000	1.476E-4	-5.695E-8	9.395E-12	-6.182E-16
	125 μ	1.000	1.934E-4	-6.792E-8	1.014E-11	-6.347E-16
	160 μ	0.998	2.910E-4	-1.224E-7	2.263E-11	-1.590E-15
Kool Mμ	26 μ	-1.291E-3	4.711E-5	-5.779E-8	2.102E-11	-2.121E-15
	60 μ	-1.850E-3	7.340E-5	-9.824E-8	4.486E-11	-7.157E-15
	75 μ	-2.135E-3	9.533E-5	-1.189E-7	4.847E-11	-6.242E-15
	90 μ	-2.769E-3	1.430E-4	-2.092E-7	1.115E-10	-2.135E-14
	125 μ	-2.421E-3	1.740E-4	-2.662E-7	1.531E-10	-3.170E-14

Permeability versus Frequency Curves, MPP

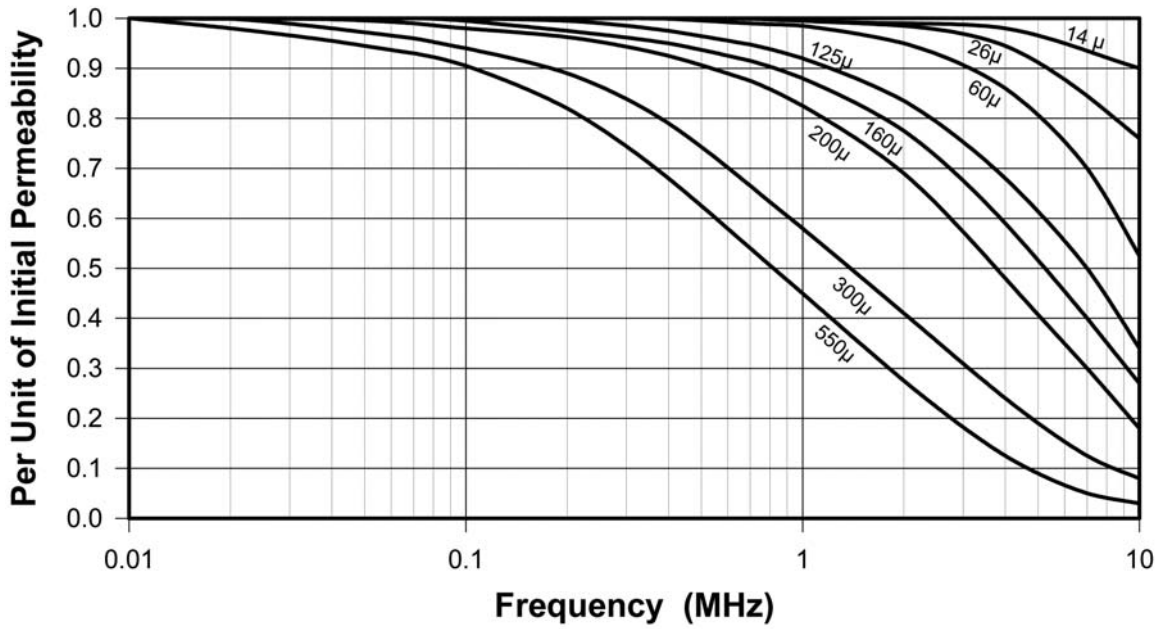

Permeability versus Frequency Curves, High Flux

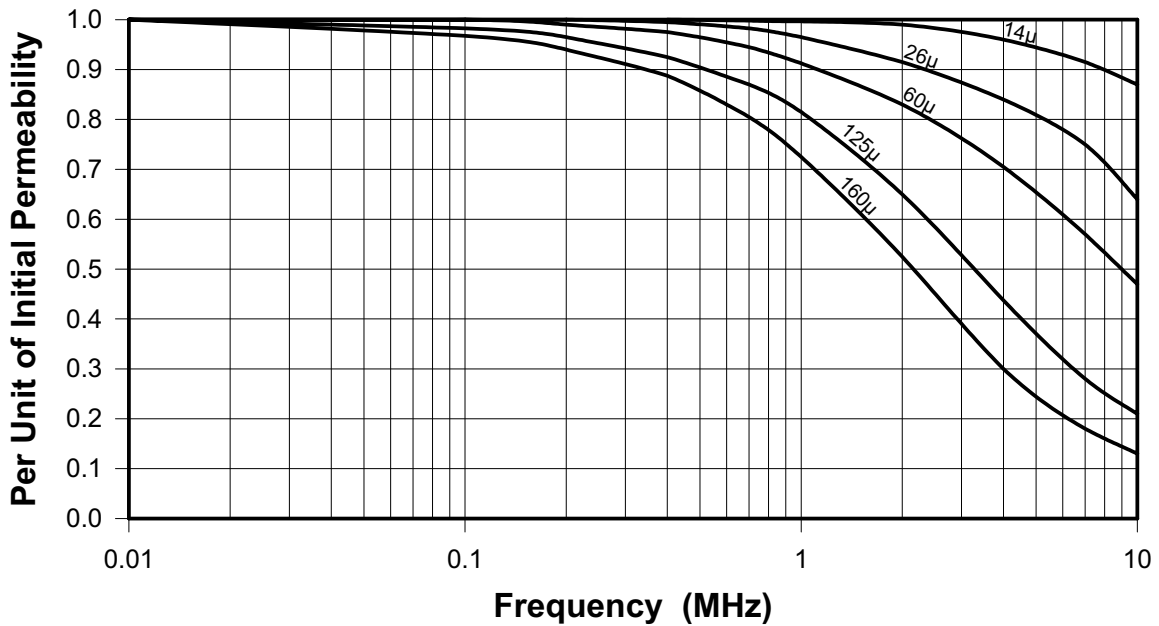

Permeability versus Frequency Curves, Kool M μ [®]

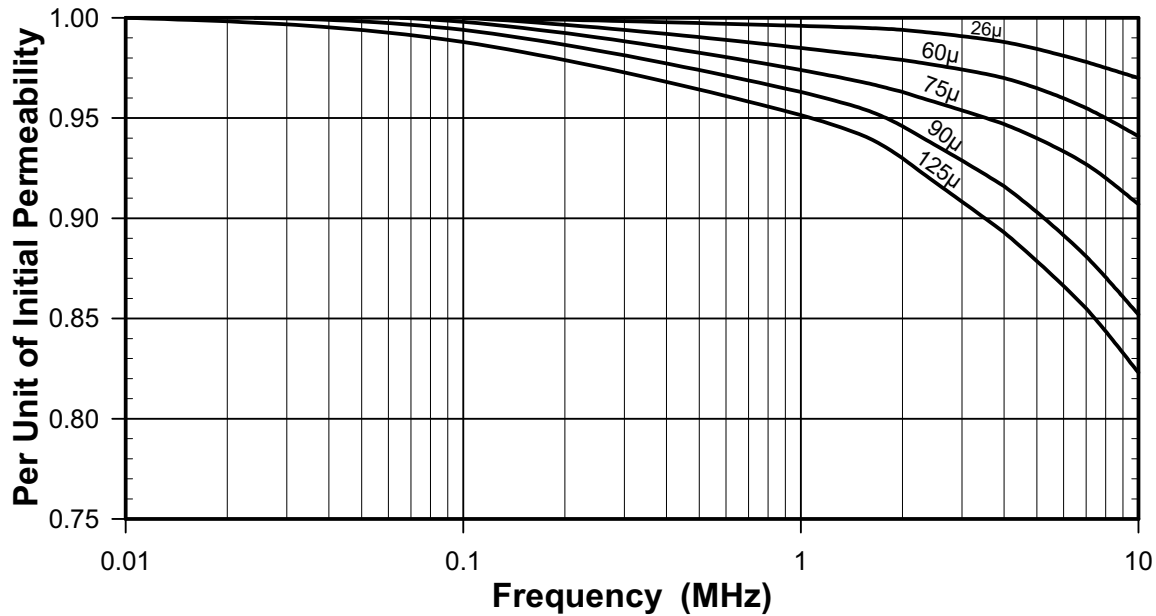

Permeability versus Frequency Curve Fit Formula

(refer to curves for units)

$$\mu_{\text{eff}} / \mu_i = \left[\frac{a + bf + cf^2}{a + df + ef^2} \right]^2$$

where:

		a	b	c	d	e
MPP	14 μ	-3.288	1.793E2	-9.742E-3	1.790E2	-9.218E-3
	26 μ	-7.930	1.823E2	-7.285E-3	1.817E2	-5.719E-3
	60 μ	-6.583	1.805E2	-1.010E-2	1.799E2	-6.944E-3
	125 μ	-3.676	1.818E2	-6.429E-3	1.812E2	2.624E-3
	160 μ	-10.544	1.816E2	7.382E-5	1.805E2	1.510E-2
	200 μ	5.551	1.809E2	-4.943E-3	1.810E2	1.400E-2
	300 μ	19.705	1.786E2	4.958E-3	1.794E2	6.160E-2
	550 μ	31.318	1.773E2	2.649E-3	1.792E2	9.260E-2
High Flux	14 μ	-3.514	180.3	-0.008689	180.0	-0.008005
	26 μ	-5.340	183.0	-0.003220	182.4	3.455E-4
	60 μ	-9.438	182.6	-4.248E-4	181.7	0.009010
	125 μ	-22.76	181.6	-0.001246	179.5	0.01970
	160 μ	-12.87	180.951	-0.001167	179.4	0.03110
Kool Mμ	26 μ	0.03919	180.6	0.01116	180.5	0.01159
	60 μ	4.182	180.4	0.01099	180.6	0.01183
	75 μ	7.559	177.4	0.01724	177.9	0.01890
	90 μ	12.80	181.2	0.008411	181.9	0.01048
	125 μ	19.18	179.2	0.01379	180.4	0.01677

Wire Table

AWG Wire Size	Resistance Ω/meter (x.305=Ω/ft)	Wire O.D. (cm) Heavy Build	Wire Area		Current Capacity, Amps (listed by columns of amps/sq.cm.)			
			Circ. Mils	sq. cm (x0.001)	200	400	600	800
8	.00207	.334	18,000	91.2	16.5	33.0	49.5	66.0
9	.00259	.298	14,350	72.7	13.1	26.2	39.3	52.4
10	.00328	.267	11,500	58.2	10.4	20.8	31.2	41.6
11	.00413	.238	9,160	46.4	8.23	16.4	24.6	32.8
12	.00522	.213	7,310	37.0	6.53	13.1	19.6	26.1
13	.00656	.1902	5,850	29.6	5.18	10.4	15.5	20.8
14	.00827	.1714	4,680	23.7	4.11	8.22	12.3	16.4
15	.01043	.1529	3,760	19.1	3.26	6.52	9.78	13.0
16	.01319	.1369	3,000	15.2	2.58	5.16	7.74	10.3
17	.01657	.1224	2,420	12.2	2.05	4.10	6.15	8.20
18	.0210	.1095	1,940	9.83	1.62	3.25	4.88	6.50
19	.0264	.0980	1,560	7.91	1.29	2.58	3.87	5.16
20	.0332	.0879	1,250	6.34	1.02	2.05	3.08	4.10
21	.0420	.0785	1,000	5.07	.812	1.63	2.44	3.25
22	.0531	.0701	810	4.11	.640	1.28	1.92	2.56
23	.0666	.0632	650	3.29	.511	1.02	1.53	2.04
24	.0843	.0566	525	2.66	.404	.808	1.21	1.62
25	.1063	.0505	425	2.15	.320	.641	.962	1.28
26	.1345	.0452	340	1.72	.253	.506	.759	1.01
27	.1686	.0409	270	1.37	.202	.403	.604	.806
28	.214	.0366	220	1.11	.159	.318	.477	.636
29	.266	.0330	180	.912	.128	.255	.382	.510
30	.341	.0295	144	.730	.100	.200	.300	.400
31	.430	.0267	117	.593	.0792	.158	.237	.316
32	.531	.0241	96.0	.487	.0640	.128	.192	.256
33	.676	.0216	77.4	.392	.0504	.101	.152	.202
34	.856	.01905	60.8	.308	.0397	.0794	.119	.159
35	1.086	.01702	49.0	.248	.0314	.0627	.0940	.125
36	1.362	.01524	39.7	.201	.0250	.0500	.0750	.100
37	1.680	.01397	32.5	.165	.0203	.0405	.0608	.0810
38	2.13	.01245	26.0	.132	.0160	.0320	.0480	.0640
39	2.78	.01092	20.2	.102	.0123	.0245	.0368	.0490
40	3.51	.00965	16.0	.081	.00961	.0192	.0288	.0384
41	4.33	.00864	13.0	.066	.00785	.0157	.0236	.0314
42	5.45	.00762	10.2	.052	.00625	.0125	.0188	.0250
43	7.02	.00686	8.40	.043	.00484	.00968	.0145	.0194
44	8.50	.00635	7.30	.037	.00400	.00800	.0120	.0160
45	10.99	.00546	5.30	.027	.00309	.00618	.00927	.0124
46	13.81	.00498	4.40	.022	.00248	.00496	.00744	.00992
47	17.36	.00452	3.60	.018	.00194	.00388	.00582	.00776
48	22.1	.00394	2.90	.015	.00175	.00350	.00525	.00700
49	27.6	.00353	2.25	.011	.00150	.00300	.00450	.00600

Notes



3.56 mm O.D.

1.78 mm I.D. x 1.52 mm HT.

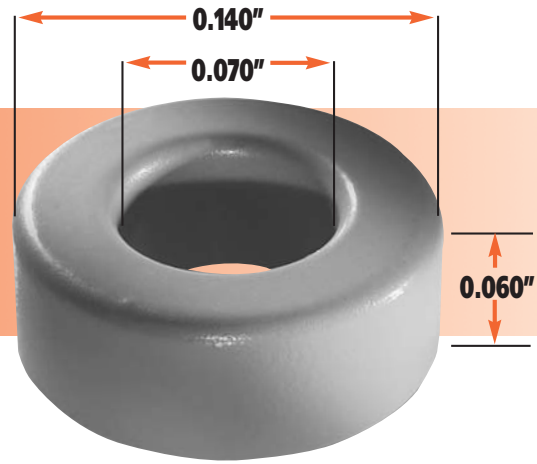

Core Dimensions (after finish)

O.D. (max.)	4.19 mm	0.165 in
I.D. (min.)	1.27 mm	0.050 in
HT. (max.)	2.16 mm	0.085 in

Permeability (μ)	$A_L \pm 8\%$ Kool M μ $A_L \pm 15\%$	Part Number			Nominal DC Resistance Ohms/mH*	B/NI Gauss per Amp. Turn*
		MPP	High Flux	Kool M μ		
60	13	-	-	77141	-	-
75	16	-	-	77445	-	-
90	19	-	-	77444	-	-
125	26	55140	-	77140	4.06	192 (< 1500 gauss)
160	33	55138	-	-	3.17	256 (<1500 gauss)
200	42	55137	-	-	2.54	296 (600 gauss)
300	62	55135	-	-	1.71	481 (<300 gauss)

Physical Characteristics

Window Area	0.018 cm ²	3,600 c.mils
Cross Section	0.0137 cm ²	0.0021 in ²
Path Length	0.817 cm	0.317 in
Volume	0.0112 cm ³	0.00067 in ³
Weight- MPP	0.094 gm	0.00019 lb
Weight- High Flux	-	-
Weight- Kool M μ	0.069 gm	0.00014 lb
Area Product	0.0002 cm ⁴	0.000006 in ⁴

Winding Turn Length

WINDING FACTOR	LENGTH/TURN	
100% (Unity)	0.698 cm	0.0229 ft
60%	0.658 cm	0.0216 ft
40%	0.619 cm	0.0203 ft
20%	0.600 cm	0.0197 ft
0%	0.594 cm	0.0195 ft

Wound Coil Dimensions

Max. O.D. (u.w.f.)	4.95 mm	0.195 in
Max. HT. (u.w.f.)	2.74 mm	0.108 in

Surface Area

Unwound Core	0.482 cm ²	0.075 in ²
40% Winding Factor	0.65 cm ²	0.101 in ²

AWG Wire Size	Turns (u.w.f.)	Rdc (Ohms, Ω) (u.w.f.)	Single Layer Turns	Single Layer Rdc. (Ohms, Ω)
29	20	0.0373	11	0.0174
30	25	0.0595	13	0.0263
31	31	0.093	14	0.0357
32	37	0.137	16	0.0506
33	46	0.217	18	0.0723
34	59	0.353	21	0.107
35	73	0.553	24	0.155
36	91	0.865	28	0.227
37	111	1.3	31	0.31
38	138	2.05	35	0.442
39	178	3.45	40	0.661
40	225	5.51	46	0.96
41	277	8.37	52	1.34
42	353	13.4	59	1.91
43	428	21	66	2.76
44	493	29.2	72	3.64
45	679	52.1	84	4.78
46	818	78.9	92	7.55
47	947	114.7	102	10.5
48	1241	191.8	117	15.4

* These values are only applicable for MPP Cores.

3.94 mm O.D.

2.24 mm I.D. x 2.54 mm HT.

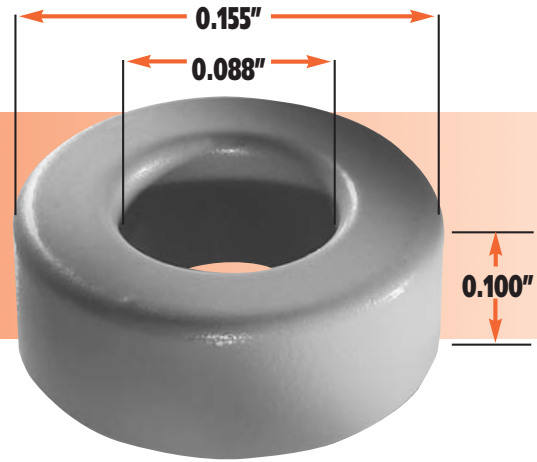

Core Dimensions (after finish)

O.D. (max.)	4.57 mm	0.180 in
I.D. (min.)	1.73 mm	0.068 in
HT. (max.)	3.18 mm	0.125 in

Permeability (μ)	$A_L \pm 8\%$ Kool M μ $A_L \pm 15\%$	Part Number			Nominal DC Resistance Ohms/mH*	B/NI Gauss per Amp. Turn*
		MPP	High Flux	Kool M μ		
60	17	-	-	77151	-	-
75	21	-	-	77155	-	-
90	25	-	-	77154	-	-
125	35	55150	-	77150	2.92	167 (<1500 gauss)
160	45	55148	-	-	2.27	213 (<1500 gauss)
200	56	55147	-	-	1.82	267 (<600 gauss)
300	84	55145	-	-	1.22	400 (<300 gauss)

Physical Characteristics

Window Area	0.0308 cm ²	6,080 c.mils
Cross Section	0.0211 cm ²	0.00327 in
Path Length	0.942 cm	0.371 in
Volume	0.0199 cm ³	0.00121 in ³
Weight- MPP	0.172 gm	0.00038 lb
Weight- High Flux	-	-
Weight- Kool M μ	0.122 gm	0.00027 lb
Area Product	0.0006 cm ⁴	0.000015 in ⁴

Winding Turn Length

WINDING FACTOR	LENGTH/TURN	
100% (Unity)	1.049 cm	0.0344 ft
60%	0.989 cm	0.0324 ft
40%	0.929 cm	0.0305 ft
20%	0.903 cm	0.0296 ft
0%	0.894 cm	0.0293 ft

Wound Coil Dimensions

Max. O.D. (u.w.f.)	5.77 mm	0.227 in
Max. HT. (u.w.f.)	4.75 mm	0.187 in

Surface Area

Unwound Core	0.76 cm ²	0.118 in ²
40% Winding Factor	1.2 cm ²	0.186 in ²

AWG Wire Size	Turns (u.w.f.)	Rdc (Ohms, Ω) (u.w.f.)	Single Layer Turns	Single Layer Rdc. (Ohms, Ω)
28	24	0.0544	13	0.0249
29	30	0.0837	15	0.0357
30	37	0.1324	17	0.0518
31	46	0.205	20	0.0768
32	56	0.309	22	0.104
33	69	0.488	25	0.151
34	88	0.787	29	0.222
35	109	1.229	33	0.32
36	134	1.916	37	0.45
37	164	2.89	41	0.615
38	205	4.57	46	0.873
39	264	7.69	53	1.32
40	333	12.31	61	1.91
41	410	18.61	68	2.63
42	522	29.8	78	3.79
43	634	46.7	87	5.46
44	730	65	94	7.13
45	1005	115.9	110	10.8
46	1221	175.4	121	14.9
47	1480	269	134	20.8

Core Data

* These values are only applicable for MPP Cores.



4.65 mm O.D.

2.36 mm I.D. x 2.54 mm HT.

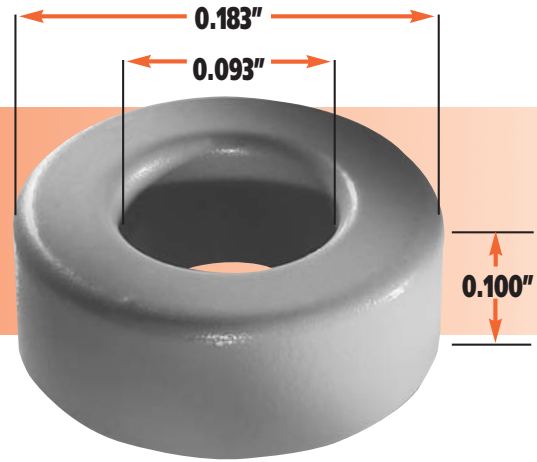

Core Dimensions (after finish)

O.D. (max.)	5.28 mm	0.208 in
I.D. (min.)	1.85 mm	0.073 in
HT. (max.)	3.18 mm	0.125 in

Permeability (μ)	$A_L \pm 8\%$ Kool M μ $A_L \pm 15\%$	Part Number			Nominal DC Resistance Ohms/mH*	B/NI Gauss per Amp. Turn*
		MPP	High Flux	Kool M μ		
60	20	55181	-	77181	5.17	71.2 (<gauss)
75	25	-	-	77185	-	-
90	30	-	-	77184	-	-
125	42	55180	-	77180	2.46	148 (<1500 gauss)
160	53	55178	-	-	1.95	190 (<1500 gauss)
200	67	55177	-	-	1.54	237 (<600 gauss)
300	99	55175	-	-	1.04	356 (<300 gauss)

Physical Characteristics

Window Area	0.029 cm ²	5,780 c.mils
Cross Section	0.0285 cm ²	0.00442 in ²
Path Length	1.062 cm	0.418 in
Volume	0.0303 cm ³	0.00185 in ³
Weight- MPP	0.25 gm	0.00056 lb
Weight- High Flux	-	-
Weight- Kool M μ	0.18 gm	0.00041 lb
Area Product	0.0008 cm ⁴	0.000020 in ⁴

Winding Turn Length

WINDING FACTOR	LENGTH/TURN	
100% (Unity)	1.143 cm	0.0375 ft
60%	1.083 cm	0.0355 ft
40%	1.024 cm	0.0336 ft
20%	0.998 cm	0.0327 ft
0%	0.988 cm	0.0324 ft

Wound Coil Dimensions

Max. O.D. (u.w.f.)	6.65 mm	0.262 in
Max. HT. (u.w.f.)	4.94 mm	0.195 in

Surface Area

Unwound Core	1.108 cm ²	0.172 in ²
40% Winding Factor	1.50 cm ²	0.233 in ²

AWG Wire Size	Turns (u.w.f.)	Rdc (Ohms, Ω) (u.w.f.)	Single Layer Turns	Single Layer Rdc. (Ohms, Ω)
27	21	0.0412	11	0.0183
28	26	0.0643	13	0.0275
29	32	0.0989	15	0.0395
30	40	0.156	17	0.0572
31	49	0.243	19	0.0807
32	60	0.366	22	0.115
33	75	0.577	24	0.16
34	95	0.93	28	0.237
35	118	1.46	32	0.343
36	145	2.26	36	0.484
37	178	3.41	40	0.664
38	222	5.4	45	0.944
39	286	9.08	52	1.43
40	361	14.5	59	2.05
41	444	22	67	2.86
42	566	35.3	76	4.08
43	688	55.2	85	5.9
44	791	76.8	92	7.72
45	1090	137	107	11.6
46	1313	207	118	16.1

* These values are only applicable for MPP Cores.

6.35 mm O.D.

2.79 mm I.D. x 2.79 mm HT.

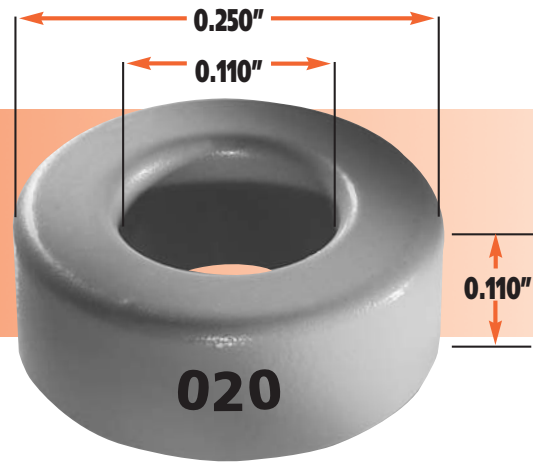

Core Dimensions (after finish)

O.D. (max.)	6.99 mm	0.275 in
I.D. (min.)	2.29 mm	0.090 in
HT. (max.)	3.43 mm	0.135 in

Permeability (μ)	$A_L \pm 8\%$ Kool M μ $A_L \pm 12\%$	Part Number			Nominal DC Resistance Ohms/mH*	B/NI Gauss per Amp. Turn*
		MPP	High Flux	Kool M μ		
14	6	55023	58023	-	14.4	12.9 (<1500 gauss)
26	10	55022	58022	-	8.65	24 (<1500 gauss)
60	24	55021	58021	77021	3.6	55.4 (<1500 gauss)
75	30	-	-	77825	-	-
90	36	-	-	77824	-	-
125	50	55020	58020	77020	1.73	116 (<1500 gauss)
160	64	55018	58018	-	1.35	148 (<1500 gauss)
200	80	55017	-	-	1.08	185 (<600 gauss)
300	120	55015	-	-	0.72	277 (<300 gauss)
550	220	55016	-	-	0.39	508 (<50 gauss)

Physical Characteristics

Window Area	0.0412 cm ²	8,100 c.mils
Cross Section	0.0470 cm ²	0.00729 in ²
Path Length	1.361 cm	0.536 in
Volume	0.0640 cm ³	0.00391 in ³
Weight- MPP	0.588 gm	0.0013 lb
Weight- High Flux	0.553 gm	0.0012 lb
Weight- Kool M μ	0.393 gm	0.0009 lb
Area Product	0.0019 cm ⁴	0.000046 in ⁴

Winding Turn Length

WINDING FACTOR	LENGTH/TURN	
100% (Unity)	1.348 cm	0.0442 ft
60%	1.273 cm	0.0417 ft
40%	1.200 cm	0.0394 ft
20%	1.168 cm	0.0383 ft
0%	1.156 cm	0.0379 ft

Wound Coil Dimensions

Max. O.D. (u.w.f.)	8.81 mm	0.347 in
Max. HT. (u.w.f.)	5.38 mm	0.212 in

Surface Area

Unwound Core	1.68 cm ²	0.260 in ²
40% Winding Factor	2.2 cm ²	0.341 in ²

AWG Wire Size	Turns (u.w.f.)	Rdc (Ohms, Ω) (u.w.f.)	Single Layer Turns	Single Layer Rdc. (Ohms, Ω)
26	24	0.0432	12	0.0186
27	30	0.0682	14	0.0273
28	37	0.1063	16	0.0395
29	45	0.1635	18	0.0554
30	56	0.259	21	0.0828
31	69	0.401	23	0.114
32	84	0.604	26	0.16
33	105	0.953	30	0.235
34	133	1.54	34	0.336
35	165	2.42	38	0.477
36	204	3.74	44	0.691
37	249	5.64	48	0.931
38	312	8.92	54	1.33
39	401	15.01	62	1.99
40	506	24	71	2.87
41	623	36.4	80	4
42	794	58.3	91	5.72
43	964	91.2	101	8.19
44	1110	127	110	10.8
45	1528	226	128	16.2

* These values are only applicable for MPP Cores.

6.60 mm O.D.

2.67 mm I.D. x 2.54 mm HT.

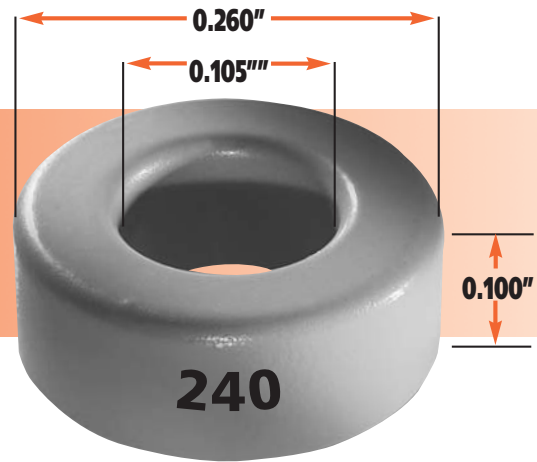

Core Dimensions (after finish)

O.D. (max.)	7.24 mm	0.285 in
I.D. (min.)	2.16 mm	0.085 in
HT. (max.)	3.18 mm	0.125 in

Permeability (μ)	$A_L \pm 8\%$ Kool M μ $A_L \pm 12\%$	Part Number			Nominal DC Resistance Ohms/mH*	B/NI Gauss per Amp. Turn*
		MPP	High Flux	Kool M μ		
14	6	55243	58243	-	14.22	12.9 (<1500 gauss)
26	11	55242	58242	-	7.76	24 (<1500 gauss)
60	26	55241	58241	77241	3.28	55.4 (<1500 gauss)
75	32	-	-	77245	-	-
90	39	-	-	77244	-	-
125	54	55240	58240	77240	1.58	116 (<1500 gauss)
160	69	55238	58238	-	1.24	148 (<1500 gauss)
200	86	55237	-	-	0.992	185 (<600 gauss)
300	130	55235	-	-	0.656	277 (<300 gauss)
550	242	55236	-	-	0.353	508 (<50 gauss)

Physical Characteristics

Window Area	0.0412 cm ²	8,100 c.mils
Cross Section	0.0476 cm ²	0.00738 in ²
Path Length	1.363 cm	0.537 in
Volume	0.0649 cm ³	0.00396 in ³
Weight- MPP	0.58 gm	0.0013 lb
Weight- High Flux	0.55 gm	0.0012 lb
Weight- Kool M μ	0.399 gm	0.00088 lb
Area Product	0.0020 cm ⁴	0.000047 in ⁴

Winding Turn Length

WINDING FACTOR	LENGTH/TURN	
100% (Unity)	1.327 cm	0.0435 ft
60%	1.251 cm	0.0410 ft
40%	1.176 cm	0.0386 ft
20%	1.144 cm	0.0375 ft
0%	1.132 cm	0.0371 ft

Wound Coil Dimensions

Max. O.D. (u.w.f.)	9.12 mm	0.359 in
Max. HT. (u.w.f.)	5.13 mm	0.202 in

Surface Area

Unwound Core	0.264 in ²	1.70 cm ²
40% Winding Factor	0.357 in ²	2.3 cm ²

AWG Wire Size	Turns (u.w.f.)	Rdc (Ohms, Ω) (u.w.f.)	Single Layer Turns	Single Layer Rdc. (Ohms, Ω)
26	24	0.0425	12	0.0183
27	30	0.0671	14	0.0267
28	37	0.1046	16	0.0388
29	45	0.1609	18	0.0542
30	56	0.255	21	0.81
31	69	0.395	23	0.112
32	84	0.595	26	0.156
33	105	0.938	30	0.229
34	133	1.513	34	0.329
35	165	2.38	39	0.479
36	204	3.68	44	0.677
37	249	5.55	48	0.912
38	312	8.78	54	1.3
39	401	14.8	62	1.95
40	506	23.7	71	2.82
41	623	35.8	80	3.92
42	794	57.3	91	5.6
43	964	89.8	101	8.02
44	1110	125	110	10.6
45	1528	223	128	15.9

* These values are only applicable for MPP Cores.

6.60 mm O.D.

2.67 mm I.D. x 4.78 mm HT.

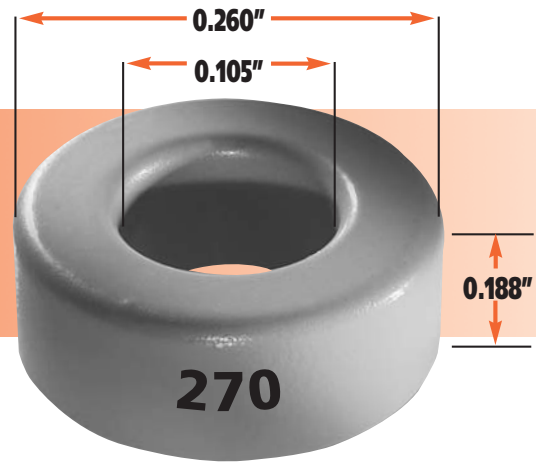

Core Dimensions (after finish)

O.D. (max.)	7.24 mm	0.285 in
I.D. (min.)	2.16 mm	0.085 in
HT. (max.)	5.54 mm	0.213 in

Permeability (μ)	$A_L \pm 8\%$ Kool M μ $A_L \pm 12\%$	Part Number			Nominal DC Resistance Ohms/mH*	B/NI Gauss per Amp. Turn*
		MPP	High Flux	Kool M μ		
14	12	55273	58273	-	10	12.9 (<1500 gauss)
26	21	55272	58272	-	5.74	24 (<1500 gauss)
60	50	55271	58271	77271	2.41	55.4 (<1500 gauss)
75	62	-	-	77875	-	-
90	74	-	-	77874	-	-
125	103	55270	58270	77270	1.17	116 (<1500 gauss)
160	132	55268	58268	-	0.913	148 (<1500 gauss)
200	165	55267	-	-	0.73	185 (<600 gauss)
300	247	55265	-	-	0.488	277 (<300 gauss)
550	466	55266	-	-	0.259	508 (50 gauss)

Physical Characteristics

Window Area	0.0384 cm ²	7,570 c.mils
Cross Section	0.0920 cm ²	0.01426 in ²
Path Length	1.363 cm	0.537 in
Volume	0.1254 cm ³	0.00765 in ³
Weight- MPP	1.09 gm	0.0024 lb
Weight- High Flux	1.03 gm	0.0023 lb
Weight- Kool M μ	0.771 gm	0.0017 lb
Area Product	0.0035 cm ⁴	0.000085 in ⁴

Winding Turn Length

WINDING FACTOR	LENGTH/TURN	
100% (Unity)	1.754 cm	0.0575 ft
60%	1.701 cm	0.0558 ft
40%	1.650 cm	0.0541 ft
20%	1.628 cm	0.0534 ft
0%	1.620 cm	0.0531 ft

Wound Coil Dimensions

Max. O.D. (u.w.f.)	9.17 mm	0.361 in
Max. HT. (u.w.f.)	7.42 mm	0.292 in

Surface Area

Unwound Core	2.41 cm ²	0.375 in ²
40% Winding Factor	2.9 cm ²	0.450 in ²

AWG Wire Size	Turns (u.w.f.)	Rdc (Ohms, Ω) (u.w.f.)	Single Layer Turns	Single Layer Rdc. (Ohms, Ω)
26	22	0.0525	12	0.0262
27	28	0.0828	13	0.0355
28	34	0.1292	16	0.0555
29	42	0.1988	17	0.0733
30	53	0.314	20	0.11
31	65	0.487	22	0.153
32	79	0.734	25	0.215
33	98	1.158	28	0.307
34	124	1.868	33	0.457
35	154	2.94	37	0.651
36	191	4.55	42	0.925
37	233	6.86	46	1.25
38	291	10.85	52	1.78
39	375	18.25	60	2.69
40	473	29.2	68	3.86
41	582	44.2	77	5.4
42	742	70.8	87	7.67
43	901	110.9	98	11.1
44	1037	154.4	106	14.6
45	1428	275	123	21.9

* These values are only applicable for MPP Cores.



6.86 mm O.D.
3.96 mm I.D. x 5.08 mm HT.

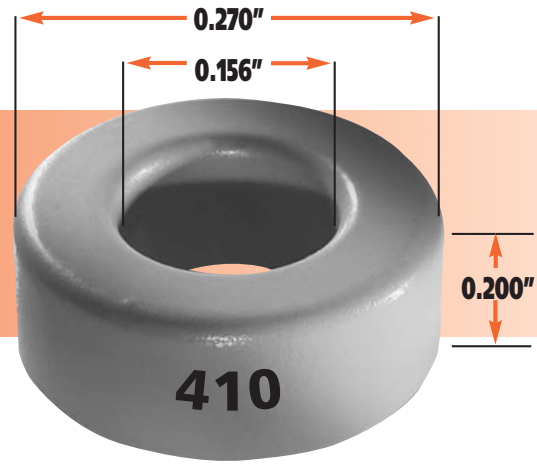

Core Dimensions (after finish)

O.D. (max.)	7.49 mm	0.295 in
I.D. (min.)	3.45 mm	0.136 in
HT. (max.)	5.71 mm	0.225 in

Permeability (μ)	$A_L \pm 8\%$ Kool M μ $A_L \pm 12\%$	Part Number			Nominal DC Resistance Ohms/mH*	B/NI Gauss per Amp. Turn*
		MPP	High Flux	Kool M μ		
14	8	55413	58413	-	-	-
26	14	55412	58412	-	-	-
60	33	55411	58411	77411	-	-
75	42	-	-	77415	-	-
90	50	-	-	77414	-	-
125	70	55410	58410	77410	-	-
160	89	55408	58408	-	-	-
200	112	55407	-	-	-	-
300	166	55405	-	-	-	-

Physical Characteristics

Window Area	0.0934 cm ²	18,500 c.mils
Cross Section	0.0725 cm ²	0.01124 in ²
Path Length	1.65 cm	0.650 in
Volume	0.1196 cm ³	0.00731in ³
Weight- MPP	1.0 gm	0.0022 lb
Weight- High Flux	0.94 gm	0.0021 lb
Weight- Kool M μ	0.736 gm	0.0016 lb
Area Product	0.0067 cm ⁴	0.000161 in ⁴

Winding Turn Length

WINDING FACTOR	LENGTH/TURN	
100% (Unity)	1.786 cm	0.0586 ft
60%	1.698 cm	0.0557 ft
40%	1.612 cm	0.0529 ft
20%	1.579 cm	0.0518 ft
0%	1.561 cm	0.0512 ft

Wound Coil Dimensions

Max. O.D. (u.w.f.)	9.60 mm	0.378 in
Max. HT. (u.w.f.)	10.0 mm	0.394 in

Surface Area

Unwound Core	2.7 cm ²	0.419 in ²
40% Winding Factor	3.2 cm ²	0.496 in ²

AWG Wire Size	Turns (u.w.f.)	Rdc (Ohms, Ω) (u.w.f.)	Single Layer Turns	Single Layer Rdc. (Ohms, Ω)
26	55	0.1321	20	0.042
27	69	0.208	23	0.0605
28	85	0.325	26	0.0869
29	103	0.49	29	0.121
30	129	0.786	33	0.176
31	159	1.221	37	0.248
32	193	1.832	41	0.34
33	239	2.89	46	0.485
34	305	4.66	53	0.708
35	378	7.33	60	1.02
36	466	11.33	67	1.42
37	570	17.1	73	1.91
38	712	27	83	2.75
39	916	45.5	95	4.12
40	1157	72.5	108	5.92
41	1424	110.1	121	8.18
42	1814	176.5	138	11.7
43	2203	276	153	16.8
44	2535	385	166	22
45	3491	685	195	33.4

* These values are only applicable for MPP Cores.

7.87 mm O.D.

3.96 mm I.D. x 3.18 mm HT.

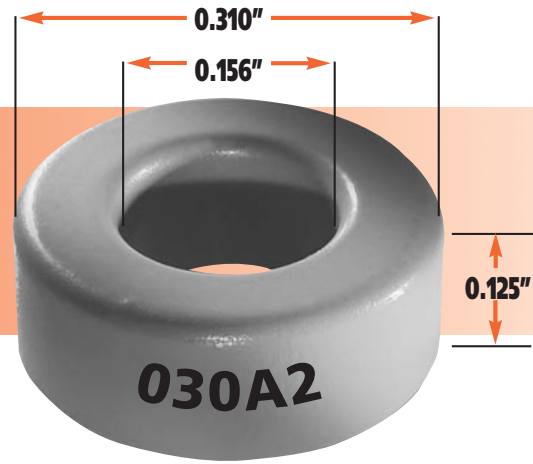

Core Dimensions (after finish)

O.D. (max.)	8.51 mm	0.335 in
I.D. (min.)	3.45 mm	0.136 in
HT. (max.)	3.81 mm	0.150 in

Permeability (μ)	$A_L \pm 8\%$ Kool M μ $A_L \pm 12\%$	Part Number			Nominal DC Resistance Ohms/mH*	B/NI Gauss per Amp. Turn*
		MPP	High Flux	Kool M μ		
14	6	55033	58033	-	7.61	9.83 (<1500 gauss)
26	11	55032	58032	-	4.15	18.3 (<1500 gauss)
60	25	55031	58031	77031	1.83	42.1 (<1500 gauss)
75	31	-	-	77835	-	-
90	37	-	-	77834	-	-
125	52	55030	58030	77030	0.878	87.8 (<1500 gauss)
160	66	55028	58028	-	0.692	112 (<1500 gauss)
200	83	55027	-	-	0.55	140 (<600 gauss)
300	124	55025	-	-	0.368	211 (<300 gauss)
550	229	55026	-	-	0.199	386 (<50 gauss)

Physical Characteristics

Window Area	0.0922 cm ²	18,200 c.mils
Cross Section	0.0615 cm ²	0.00953 in ²
Path Length	1.787 cm	0.704 in
Volume	0.1099 cm ³	0.00671 in ³
Weight- MPP	0.92 gm	0.0020 lb
Weight- High Flux	0.87 gm	0.0019 lb
Weight- Kool M μ	0.676 gm	0.0015 lb
Area Product	0.0057 cm ⁴	0.000136 in ⁴

Winding Turn Length

WINDING FACTOR	LENGTH/TURN	
100% (Unity)	1.598 cm	0.0524 ft
60%	1.471 cm	0.0482 ft
40%	1.347 cm	0.0442 ft
20%	1.292 cm	0.0424 ft
0%	1.272 cm	0.0417 ft

Wound Coil Dimensions

Max. O.D. (u.w.f.)	11.0 mm	0.433 in
Max. HT. (u.w.f.)	6.73 mm	0.265 in

Surface Area

Unwound Core	2.38 cm ²	0.369 in ²
40% Winding Factor	3.2 cm ²	0.496 in ²

AWG Wire Size	Turns (u.w.f.)	Rdc (Ohms, Ω) (u.w.f.)	Single Layer Turns	Single Layer Rdc. (Ohms, Ω)
22	23	0.0191	12	0.0082
23	28	0.0298	13	0.0109
24	35	0.0467	15	0.016
25	43	0.0728	18	0.0243
26	54	0.1152	20	0.0342
27	68	0.1818	23	0.0493
28	83	0.284	26	0.0707
29	101	0.436	29	0.0982
30	127	0.69	33	0.143
31	156	1.069	37	0.202
32	190	1.612	41	0.277
33	235	2.54	46	0.395
34	300	4.1	53	0.577
35	372	6.45	60	0.828
36	459	9.98	67	1.16
37	561	15.04	73	1.56
38	701	23.8	83	2.24
39	902	40	95	3.79
40	1139	64.1	108	4.82
41	1402	97	121	6.65

Core Data

* These values are only applicable for MPP Cores.



9.65 mm O.D.

4.78 mm I.D. x 3.18 mm HT.

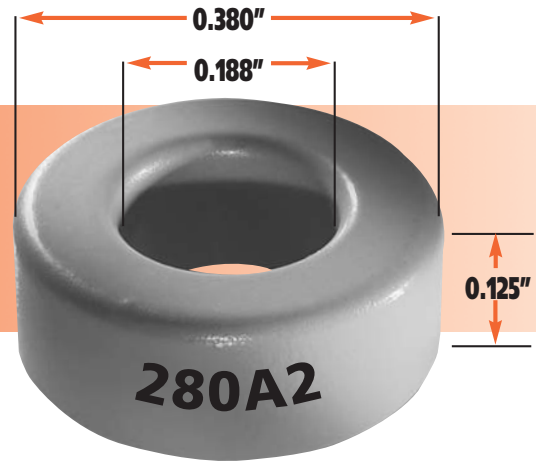

Core Dimensions (after finish)

O.D. (max.)	10.29 mm	0.405 in
I.D. (min.)	4.27 mm	0.168 in
HT. (max.)	3.81 mm	0.150 in

Permeability (μ)	$A_L \pm 8\%$ Kool M μ $A_L \pm 12\%$	Part Number			Nominal DC Resistance Ohms/mH*	B/NI Gauss per Amp. Turn*
		MPP	High Flux	Kool M μ		
14	6	55283	58283	-	5.51	8.08 (<1500 gauss)
26	11	55282	58282	-	3.01	15 (<1500 gauss)
60	25	55281	58281	77281	1.32	34.6 (<1500 gauss)
75	32	-	-	77885	-	-
90	38	-	-	77884	-	-
125	53	55280	58280	77280	0.624	72.1 (<1500 gauss)
160	68	55278	58278	-	0.486	92.3 (<1500 gauss)
200	84	55277	-	-	0.394	115 (<600 gauss)
300	128	55275	-	-	0.258	173 (<300 gauss)
550	232	55276	-	-	0.143	317 (<50 gauss)

Physical Characteristics

Window Area	0.1429 cm ²	28,200 c.mils
Cross Section	0.0752 cm ²	0.01166 in ²
Path Length	2.18 cm	0.858 in
Volume	0.1639 cm ³	0.0100 in ³
Weight- MPP	1.4 gm	0.0030 lb
Weight- High Flux	1.3 gm	0.0028 lb
Weight- Kool M μ	1.008 gm	0.00222 lb
Area Product	0.0107 cm ⁴	0.000258 in ⁴

Winding Turn Length

WINDING FACTOR	LENGTH/TURN	
100% (Unity)	1.793 cm	0.0588 ft
60%	1.627 cm	0.0533 ft
40%	1.465 cm	0.0480 ft
20%	1.393 cm	0.0457 ft
0%	1.366 cm	0.0448 ft

Wound Coil Dimensions

Max. O.D. (u.w.f.)	13.4 mm	0.526 in
Max. HT. (u.w.f.)	7.44 mm	0.293 in

Surface Area

Unwound Core	3.12 cm ²	0.483 in ²
40% Winding Factor	4.4 cm ²	0.682 in ²

AWG Wire Size	Turns (u.w.f.)	Rdc (Ohms, Ω) (u.w.f.)	Single Layer Turns	Single Layer Rdc. (Ohms, Ω)
20	23	0.01345	12	0.0054
21	28	0.0212	13	0.0074
22	35	0.0332	15	0.0108
23	43	0.0518	18	0.0164
24	54	0.0812	20	0.0231
25	66	0.1265	23	0.0334
26	83	0.2	26	0.0478
27	105	0.316	29	0.0668
28	128	0.493	33	0.0966
29	157	0.758	37	0.135
30	196	1.199	42	0.195
31	241	1.858	47	0.276
32	294	2.8	52	0.377
33	365	4.42	58	0.535
34	464	7.12	67	0.783
35	576	11.21	75	1.11
36	711	17.3	84	1.57
37	868	26.1	92	2.11
38	1086	41.4	104	3.02
39	1397	69.6	119	4.52

* These values are only applicable for MPP Cores.

9.65 mm O.D.

4.78 mm I.D. x 3.96 mm HT.

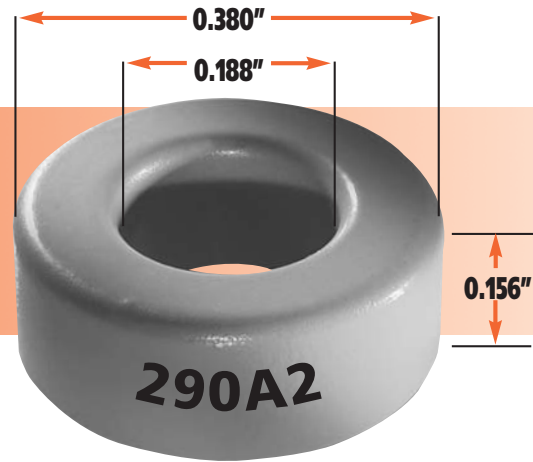

Core Dimensions (after finish)

O.D. (max.)	10.29 mm	0.405 in
I.D. (min.)	4.27 mm	0.168 in
HT. (max.)	4.60 mm	0.181 in

Permeability (μ)	$A_L \pm 8\%$ Kool M μ $A_L \pm 12\%$	Part Number			Nominal DC Resistance Ohms/mH*	B/NI Gauss per Amp. Turn*
		MPP	High Flux	Kool M μ		
14	7	55293	58293	-	5.07	8.08 (<1500 gauss)
26	14	55292	58292	-	2.54	15 (<1500 gauss)
60	32	55291	58291	77291	1.11	34.6 (<1500 gauss)
75	40	-	-	77295	-	-
90	48	-	-	77294	-	-
125	66	55290	58290	77290	0.538	72.1 (<1500 gauss)
160	84	55288	58288	-	0.423	92.3 (<1500 gauss)
200	105	55287	-	-	0.338	115 (<600 gauss)
300	159	55285	-	-	0.223	173 (<300 gauss)
550	290	55286	-	-	0.122	317 (<50 gauss)

Physical Characteristics

Window Area	0.1429 cm ²	28,200 c.mils
Cross Section	0.0945 cm ²	0.01465 in ²
Path Length	2.18 cm	0.859 in
Volume	0.206 cm ³	0.0126 in ³
Weight- MPP	1.8 gm	0.0039 lb
Weight- High Flux	1.7 gm	0.0037 lb
Weight- Kool M μ	1.44 gm	0.0032 lb
Area Product	0.0135 cm ⁴	0.000325 in ⁴

Winding Turn Length

WINDING FACTOR	LENGTH/TURN	
100% (Unity)	1.928 cm	0.0632 ft
60%	1.768 cm	0.0580 ft
40%	1.613 cm	0.0529 ft
20%	1.545 cm	0.0506 ft
0%	1.519 cm	0.0498 ft

Wound Coil Dimensions

Max. O.D. (u.w.f.)	13.4 mm	0.526 in
Max. HT. (u.w.f.)	8.20 mm	0.323 in

Surface Area

Unwound Core	3.46 cm ²	0.537 in ²
40% Winding Factor	4.7 cm ²	0.729 in ²

AWG Wire Size	Turns (u.w.f.)	Rdc (Ohms, Ω) (u.w.f.)	Single Layer Turns	Single Layer Rdc. (Ohms, Ω)
20	23	0.01446	12	0.00605
21	28	0.0228	13	0.00826
22	35	0.0357	15	0.012
23	43	0.0557	18	0.0182
24	54	0.0873	20	0.0256
25	66	0.136	23	0.0371
26	83	0.215	26	0.0531
27	105	0.34	29	0.0743
28	128	0.529	33	0.107
29	157	0.815	37	0.15
30	196	1.288	42	0.217
31	241	1.997	47	0.307
32	294	3.01	52	0.42
33	365	4.75	58	0.594
34	464	7.66	67	0.871
35	576	12.05	75	1.24
36	711	18.65	84	1.74
37	868	28.1	92	2.34
38	1086	44.5	104	3.35
39	1397	74.8	119	5.02

* These values are only applicable for MPP Cores.



10.2 mm O.D.

5.08 mm I.D. x 3.96 mm HT.

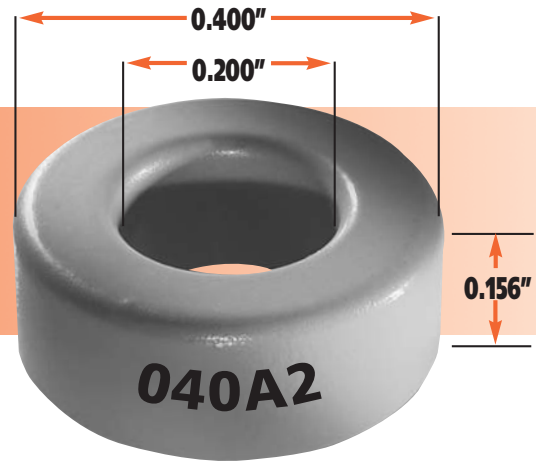

Core Dimensions (after finish)

O.D. (max.)	10.80 mm	0.425 in
I.D. (min.)	4.57 mm	0.180 in
HT. (max.)	4.60 mm	0.181 in

Permeability (μ)	$A_L \pm 8\%$ Kool $M\mu$ $A_L \pm 12\%$	Part Number			Nominal DC Resistance Ohms/mH*	B/NI Gauss per Amp. Turn*
		MPP	High Flux	Kool $M\mu$		
14	7	55043	58043	-	4.55	7.39 (<1500 gauss)
26	14	55042	58042	-	2.28	13.7 (<1500 gauss)
60	32	55041	58041	77041	0.996	31.7 (<1500 gauss)
75	40	-	-	77845	-	-
90	48	-	-	77844	-	-
125	66	55040	58040	77040	0.483	66 (<1500 gauss)
160	84	55038	58038	-	0.38	84.5 (<1500 gauss)
200	105	55037	-	-	0.304	106 (<600 gauss)
300	159	55035	-	-	0.200	158 (<300 gauss)
550	290	55036	-	-	0.11	290 (<50 gauss)

Physical Characteristics

Window Area	0.164 cm ²	32,400 c.mils
Cross Section	0.1000 cm ²	0.01550 in ²
Path Length	2.38 cm	0.906 in
Volume	0.238 cm ³	0.014 in ³
Weight- MPP	1.91 gm.	0.0041 lb
Weight- High Flux	1.80 gm	0.0039 lb
Weight- Kool $M\mu$	1.46 gm	0.0032 lb
Area Product	0.0164 cm ⁴	0.000395 in ⁴

Winding Turn Length

WINDING FACTOR	LENGTH/TURN	
100% (Unity)	1.986 cm	0.0651 ft
60%	1.811 cm	0.0594 ft
40%	1.640 cm	0.0538 ft
20%	1.566 cm	0.0513 ft
0%	1.537 cm	0.0504 ft

Wound Coil Dimensions

Max. O.D. (u.w.f.)	14.1 mm	0.554 in
Max. HT. (u.w.f.)	8.46 mm	0.333 in

Surface Area

Unwound Core	3.703 cm ²	0.574 in ²
40% Winding Factor	5.1 cm ²	0.791 in ²

AWG Wire Size	Turns (u.w.f.)	Rdc (Ohms, Ω) (u.w.f.)	Single Layer Turns	Single Layer Rdc. (Ohms, Ω)
20	26	0.01709	13	0.00663
21	32	0.0267	15	0.00968
22	40	0.0422	17	0.0139
23	50	0.0659	19	0.0195
24	62	0.1032	22	0.0285
25	76	0.1608	25	0.0408
26	95	0.254	28	0.0579
27	120	0.402	31	0.0804
28	147	0.626	36	0.119
29	180	0.963	40	0.164
30	225	1.523	45	0.236
31	277	2.36	50	0.33
32	338	3.56	56	0.457
33	419	5.61	63	0.654
34	533	9.05	72	0.947
35	661	14.25	81	1.35
36	816	22	91	1.9
37	1000	33.3	99	2.56
38	1246	52.6	112	3.66
39	1604	88.4	128	5.46

* These values are only applicable for MPP Cores.

11.2 mm O.D.

6.35 mm I.D. x 3.96 mm HT.

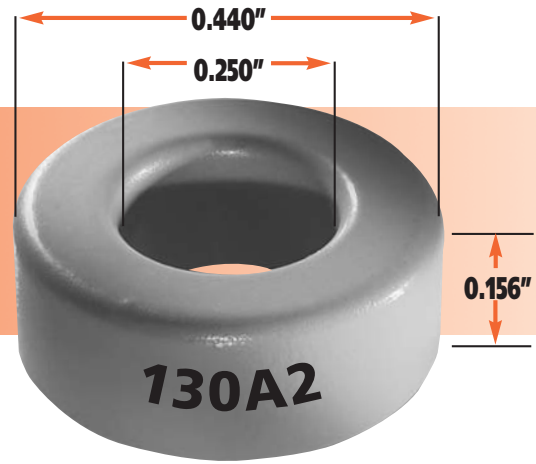

Core Dimensions (after finish)

O.D. (max.)	11.81 mm	0.465 in
I.D. (min.)	5.84 mm	0.230 in
HT. (max.)	4.60 mm	0.181 in

Permeability (μ)	$A_L \pm 8\%$ Kool M μ $A_L \pm 12\%$	Part Number			Nominal DC Resistance Ohms/mH*	B/NI Gauss per Amp. Turn*
		MPP	High Flux	Kool M μ		
14	6	55133	58133	-	4.1	6.54 (<1500 gauss)
26	11	55132	58132	-	2.23	12.1 (<1500 gauss)
60	26	55131	58131	77131	0.945	28.0 (<1500 gauss)
75	32	-	-	77335	-	-
90	38	-	-	77334	-	-
125	53	55130	58130	77130	0.464	58.4 (<1500 gauss)
160	68	55128	58128	-	0.361	74.7 (<1500 gauss)
200	85	55127	-	-	0.289	93.4 (<600 gauss)
300	127	55125	-	-	0.194	140 (<300 gauss)

Physical Characteristics

Window Area	0.273 cm ²	53,800 c.mils
Cross Section	0.0906 cm ²	0.0140 in ²
Path Length	2.69 cm	1.08 in
Volume	0.2437 cm ³	0.01487 in ³
Weight- MPP	2.12 gm	0.0046 lb
Weight- High Flux	1.99 gm	0.0043 lb
Weight- Kool M μ	1.499 gm	0.0033 lb
Area Product	0.0247 cm ⁴	0.000592 in ⁴

Winding Turn Length

WINDING FACTOR	LENGTH/TURN	
100% (Unity)	2.195 cm	0.0720 ft
60%	1.942 cm	0.0637 ft
40%	1.695 cm	0.0556 ft
20%	1.585 cm	0.0520 ft
0%	1.545 cm	0.0507 ft

Wound Coil Dimensions

Max. O.D. (u.w.f.)	15.7 mm	0.618 in
Max. HT. (u.w.f.)	9.0 mm	0.353 in

Surface Area

Unwound Core	4.31 cm ²	0.669 in ²
40% Winding Factor	6.0 cm ²	0.936 in ²

AWG Wire Size	Turns (u.w.f.)	Rdc (Ohms, Ω) (u.w.f.)	Single Layer Turns	Single Layer Rdc. (Ohms, Ω)
16	17	0.00533	10	0.00203
17	22	0.00808	11	0.00282
18	28	0.01276	13	0.00422
19	34	0.02	15	0.00612
20	43	0.03192	17	0.00873
21	54	0.04958	20	0.013
22	66	0.07747	23	0.0188
23	83	0.121	26	0.0268
24	102	0.1896	29	0.0378
25	127	0.295	33	0.0543
26	158	0.467	37	0.077
27	199	0.737	42	0.109
28	245	1.15	47	0.155
29	299	1.747	52	0.214
30	374	2.8	59	0.311
31	460	4.34	66	0.438
32	560	6.54	73	0.6
33	695	10.31	82	0.856
34	885	16.63	93	1.23
35	1098	26.2	105	1.76

* These values are only applicable for MPP Cores.



12.7 mm O.D.

7.62 mm I.D. x 4.75 mm HT.

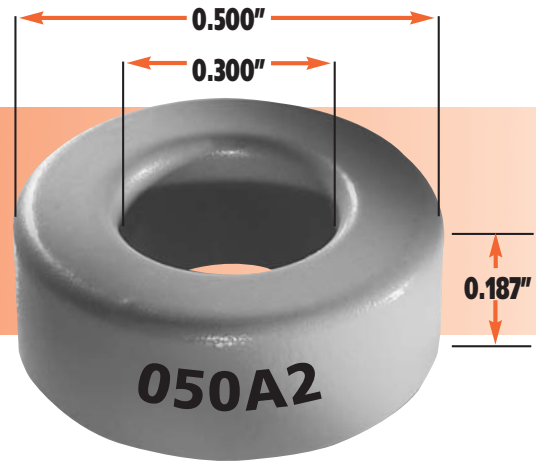

Core Dimensions (after finish)

O.D. (max.)	13.46 mm	0.530 in
I.D. (min.)	6.99 mm	0.275 in
HT. (max.)	5.51 mm	0.217 in

Permeability (μ)	$A_L \pm 8\%$	Part Number			Nominal DC Resistance Ohms/mH*	B/NI Gauss per Amp. Turn*
		MPP	High Flux	Kool M μ		
14	6.4	55053	58053	-	2.67	5.64 (<1500 gauss)
26	12	55052	58052	-	1.42	10.5 (<1500 gauss)
60	27	55051	58051	77051	0.633	24.2 (<1500 gauss)
75	34	-	-	77055	-	-
90	40	-	-	77054	-	-
125	56	55050	58050	77050	0.305	50.4 (<1500 gauss)
160	72	55048	58048	-	0.237	64.5 (<1500 gauss)
200	90	55047	-	-	0.189	80.6 (<600 gauss)
300	134	55045	-	-	0.127	121 (<300 gauss)
550	255	55046	-	-	0.067	222 (<50 gauss)

Physical Characteristics

Window Area	0.383 cm ²	75,600 c.mils
Cross Section	0.1140 cm ²	0.01767 in ²
Path Length	3.12 cm	1.229 in
Volume	0.356 cm ³	0.0217 in ³
Weight- MPP	3.07 gm	0.0064 lb
Weight- High Flux	2.90 gm	0.0060 lb
Weight- Kool M μ	2.20 gm.	0.0049 lb
Area Product	0.0437 cm ⁴	0.001049 in ⁴

Winding Turn Length

WINDING FACTOR	LENGTH/TURN	
100% (Unity)	2.49 cm	0.0815 ft
60%	2.20 cm	0.0721 ft
40%	1.920 cm	0.0629 ft
20%	1.797 cm	0.0589 ft
0%	1.751 cm	0.0574 ft

Wound Coil Dimensions

Max. O.D. (u.w.f.)	18.2 mm	0.717 in
Max. HT. (u.w.f.)	11.5 mm	0.451 in

Surface Area

Unwound Core	5.60 cm ²	0.870 in ²
40% Winding Factor	8.1 cm ²	1.26 in ²

AWG Wire Size	Turns (u.w.f.)	Rdc (Ohms, Ω) (u.w.f.)	Single Layer Turns	Single Layer Rdc. (Ohms, Ω)
16	25	0.00826	12	0.00276
17	31	0.0129	14	0.00406
18	39	0.0203	16	0.00587
19	48	0.0318	19	0.00877
20	61	0.05	21	0.0122
21	76	0.0789	24	0.0176
22	93	0.1233	28	0.026
23	116	0.1925	31	0.0362
24	144	0.302	35	0.0516
25	178	0.47	40	0.0744
26	222	0.743	45	0.106
27	280	1.173	50	0.148
28	344	1.829	56	0.21
29	420	2.81	63	0.293
30	525	4.45	71	0.434
31	646	6.9	79	0.594
32	788	10.4	87	0.809
33	977	16.4	98	1.16
34	1244	26.5	112	1.68
35	1543	41.6	125	2.37

* These values are only applicable for MPP Cores.

16.5 mm O.D.

10.2 mm I.D. x 6.35 mm HT.

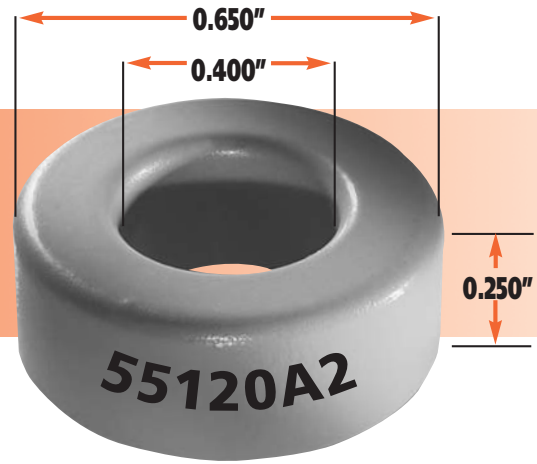

Core Dimensions (after finish)

O.D. (max.)	17.40 mm	0.680 in
I.D. (min.)	9.53 mm	0.375 in
HT. (max.)	7.11 mm	0.280 in

Permeability (μ)	$A_L \pm 8\%$	Part Number			Nominal DC Resistance Ohms/mH*	B/NI Gauss per Amp. Turn*
		MPP	High Flux	Kool M μ		
14	8	55123	58123	-	1.458	4.28 (<1500 gauss)
26	15	55122	58122	-	0.778	7.96 (<1500 gauss)
60	35	55121	58121	77121	0.333	18.4 (<1500 gauss)
75	43	-	-	77225	-	-
90	52	-	-	77224	-	-
125	72	55120	58120	77120	0.162	38.3 (<1500 gauss)
160	92	55118	58118	-	0.127	49 (<1500 gauss)
200	115	55117	-	-	0.101	61.2 (<600 gauss)
300	173	55115	-	-	0.674	91.8 (<300 gauss)
550	317	55116	-	-	0.367	169 (<50 gauss)

Physical Characteristics

Window Area	0.713 cm ²	140,600 c.mils
Cross Section	0.1920 cm ²	0.0298 in ²
Path Length	4.11 cm	1.619 in
Volume	0.789 cm ³	0.048 in ³
Weight- MPP	6.78 gm	0.015 lb
Weight- High Flux	6.34 gm	0.014 lb
Weight- Kool M μ	4.98 gm	0.011 lb
Area Product	0.1369 cm ⁴	0.0029 in ⁴

Winding Turn Length

WINDING FACTOR	LENGTH/TURN	
100% (Unity)	3.22 cm	0.1057 ft
60%	2.82 cm	0.0926 ft
40%	2.44 cm	0.0798 ft
20%	2.26 cm	0.0742 ft
0%	2.20 cm	0.0721 ft

Wound Coil Dimensions

Max. O.D. (u.w.f.)	23.7 mm	0.932 in
Max. HT. (u.w.f.)	15.2 mm	0.599 in

Surface Area

Unwound Core	9.2 cm ²	1.43 in ²
40% Winding Factor	13.6 cm ²	2.11 in ²

AWG Wire Size	Turns (u.w.f.)	Rdc (Ohms, Ω) (u.w.f.)	Single Layer Turns	Single Layer Rdc. (Ohms, Ω)
13	24	0.00508	12	0.00174
14	30	0.008	14	0.00254
15	37	0.01257	16	0.00366
16	47	0.01992	18	0.00522
17	58	0.031	21	0.00765
18	72	0.049	24	0.0111
19	90	0.0767	27	0.0157
20	113	0.1205	30	0.0219
21	141	0.1903	34	0.0314
22	174	0.297	39	0.0455
23	216	0.464	44	0.0644
24	268	0.728	49	0.0906
25	331	1.133	56	0.131
26	414	1.792	63	0.189
27	521	2.83	70	0.26
28	639	4.41	78	0.368
29	781	6.79	87	0.51
30	977	10.74	98	0.735
31	1202	16.64	108	1.02
32	1465	25.1	121	1.41

* These values are only applicable for MPP Cores.

17.3 mm O.D.

9.65 mm I.D. x 6.35 mm HT.

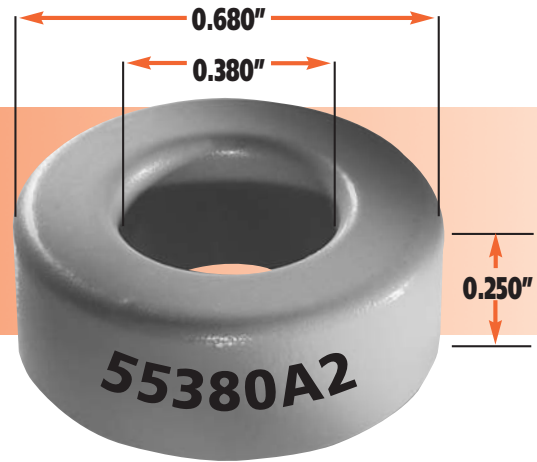

Core Dimensions (after finish)

O.D. (max.)	18.03 mm	0.710 in
I.D. (min.)	9.02 mm	0.355 in
HT. (max.)	7.11 mm	0.280 in

Permeability (μ)	$A_L \pm 8\%$	Part Number			Nominal DC Resistance Ohms/mH*	B/NI Gauss per Amp. Turn*
		MPP	High Flux	Kool M μ		
14	10	55383	58383	-	1.486	4.25 (<1500 gauss)
26	19	55382	58382	-	0.782	7.89 (<1500 gauss)
60	43	55381	58381	77381	0.346	18.2 (<1500 gauss)
75	53	-	-	77385	-	-
90	64	-	-	77384	-	-
125	89	55380	58380	77380	0.167	37.9 (<1500 gauss)
160	114	55378	58378	-	0.13	48.5 (<1500 gauss)
200	142	55377	-	-	0.105	60.7 (<600 gauss)
300	214	55375	-	-	0.069	91 (<300 gauss)

Physical Characteristics

Window Area	0.576 cm ²	126,000 c.mils
Cross Section	0.232 cm ²	0.0360 in ²
Path Length	4.14 cm	1.63 in
Volume	0.960 cm ³	0.059 in ³
Weight- MPP	8.16 gm	0.018 lb
Weight- High Flux	7.7 gm	0.017 lb
Weight- Kool M μ	5.9 gm	0.013 lb
Area Product	0.134 cm ⁴	0.00321 in ⁴

Winding Turn Length

WINDING FACTOR	LENGTH/TURN	
100% (Unity)	3.67 cm	0.1204 ft
60%	3.15 cm	0.1032 ft
40%	2.64 cm	0.0864 ft
20%	2.41 cm	0.0791 ft
0%	2.33 cm	0.0763 ft

Wound Coil Dimensions

Max. O.D. (u.w.f.)	24.9 mm	0.980 in
Max. HT. (u.w.f.)	16.3 mm	0.641 in

Surface Area

Unwound Core	9.9 cm ²	1.53 in ²
40% Winding Factor	14.7 cm ²	2.28 in ²

AWG Wire Size	Turns (u.w.f.)	Rdc (Ohms, Ω) (u.w.f.)	Single Layer Turns	Single Layer Rdc. (Ohms, Ω)
13	21	0.00506	11	0.00167
14	26	0.00789	13	0.0025
15	33	0.0126	15	0.00364
16	42	0.0203	17	0.00521
17	52	0.0316	19	0.00732
18	64	0.0492	22	0.0107
19	80	0.0775	25	0.0154
20	100	0.122	29	0.0224
21	126	0.194	32	0.0215
22	155	0.302	37	0.0313
23	193	0.472	41	0.0457
24	240	0.743	46	0.0635
25	296	1.15	52	0.0902
26	370	1.83	59	0.129
27	466	2.88	66	0.185
28	572	4.49	74	0.259
29	700	6.84	82	0.369
30	875	10.96	92	0.508
31	1076	16.97	102	0.73
32	1312	25.6	114	1.02

* These values are only applicable for MPP Cores.

20.3 mm O.D.

12.7 mm I.D. x 6.35 mm HT.

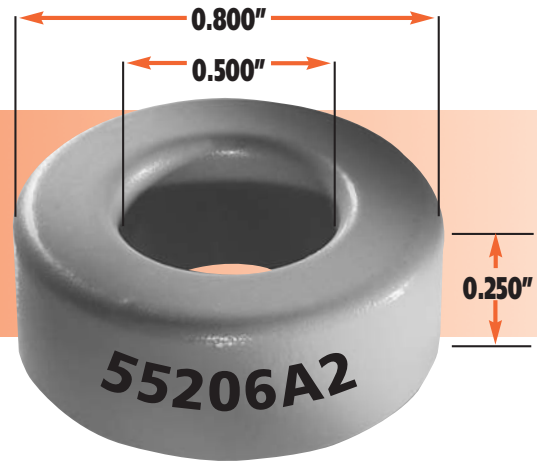

Core Dimensions (after finish)

O.D. (max.)	21.1 mm	0.830 in
I.D. (min.)	12.07 mm	0.475 in
HT. (max.)	7.11 mm	0.280 in

Permeability (μ)	$A_L \pm 8\%$	Part Number			Nominal DC Resistance Ohms/mH*	B/NI Gauss per Amp. Turn*
		MPP	High Flux	Kool M μ		
14	7.8	55209	58209	-	1.03	3.46 (<1500 gauss)
26	14	55208	58208	-	0.573	6.42 (<1500 gauss)
60	32	55848	58848	77848	0.251	14.8 (<1500 gauss)
75	41	-	-	77211	-	-
90	49	-	-	77210	-	-
125	68	55206	58206	77206	0.118	30.9 (<1500 gauss)
160	87	55204	58204	-	0.0922	39.5 (<1500 gauss)
200	109	55203	-	-	0.0736	49.4 (<600 gauss)
300	163	55201	-	-	0.0492	74.1 (<300 gauss)
550	320	55202	-	-	0.025	136 (<50 gauss)

Physical Characteristics

Window Area	1.14 cm ²	225,600 c.mils
Cross Section	0.226 cm ²	0.0350 in ²
Path Length	5.09 cm	2.01 in
Volume	1.15 cm ³	0.0703 in ³
Weight- MPP	9.4 gm	0.023 lb
Weight- High Flux	8.9 gm	0.022 lb
Weight- Kool M μ	7.1 gm	0.016 lb
Area Product	0.258 cm ⁴	0.00620 in ⁴

Winding Turn Length

WINDING FACTOR	LENGTH/TURN	
100% (Unity)	3.67 cm	0.1204 ft
60%	3.15 cm	0.1032 ft
40%	2.64 cm	0.0864 ft
20%	2.41 cm	0.0791 ft
0%	2.33 cm	0.0763 ft

Wound Coil Dimensions

Max. O.D. (u.w.f.)	29.2 mm	1.148 in
Max. HT. (u.w.f.)	17.4 mm	0.648 in

Surface Area

Unwound Core	12.1 cm ²	1.88 in ²
40% Winding Factor	18.9 cm ²	2.93 in ²

AWG Wire Size	Turns (u.w.f.)	Rdc (Ohms, Ω) (u.w.f.)	Single Layer Turns	Single Layer Rdc. (Ohms, Ω)
11	25	0.00374	12	0.001354
12	31	0.00591	14	0.0017
13	39	0.00929	16	0.00245
14	48	0.01463	18	0.00347
15	60	0.023	21	0.0051
16	75	0.0364	24	0.00736
17	93	0.0567	27	0.0104
18	116	0.0895	31	0.0151
19	145	0.1402	35	0.0215
20	181	0.22	39	0.0301
21	226	0.348	45	0.0439
22	279	0.543	50	0.0618
23	347	0.848	56	0.0867
24	430	1.33	63	0.124
25	531	2.07	71	0.176
26	664	3.28	80	0.25
27	836	5.17	89	0.349
28	1026	8.06	100	0.498
29	1253	12.41	111	0.688
30	1567	19.62	125	0.992

* These values are only applicable for MPP Cores.

22.9 mm O.D.

14.0 mm I.D. x 7.62 mm HT.

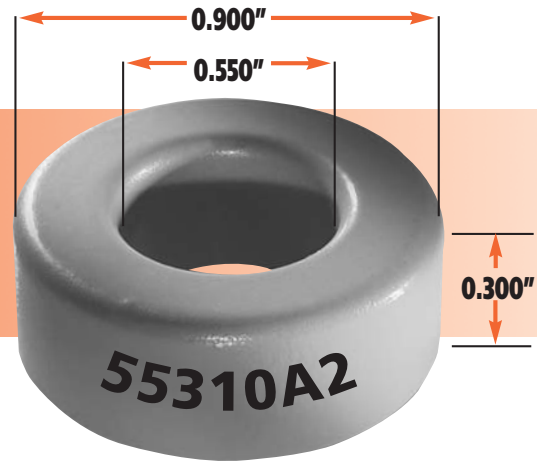

Core Dimensions (after finish)

O.D. (max.)	23.6 mm	0.930 in
I.D. (min.)	13.34 mm	0.525 in
HT. (max.)	8.38 mm	0.330 in

Permeability (μ)	$A_L \pm 8\%$	Part Number			Nominal DC Resistance Ohms/mH*	B/NI Gauss per Amp. Turn*
		MPP	High Flux	Kool M μ		
14	9.9	55313	58313	-	0.754	3.11 (<1500 gauss)
26	19	55312	58312	77312	0.393	5.77 (<1500 gauss)
60	43	55059	58059	77059	0.174	13.3 (<1500 gauss)
75	54	-	-	77315	-	-
90	65	-	-	77314	-	-
125	90	55310	58310	77310	0.083	27.8 (<1500 gauss)
160	115	55308	58308	-	0.0649	35.5 (<1500 gauss)
200	144	55307	-	-	0.0518	44.4 (<600 gauss)
300	216	55305	-	-	0.0345	66.6 (<300 gauss)
550	396	55306	-	-	0.0188	122 (< 50 gauss)

Physical Characteristics

Window Area	1.41 cm ²	277,700 c.mils
Cross Section	0.331 cm ²	0.0513 in ²
Path Length	5.67 cm	2.23 in
Volume	1.88 cm ³	0.114 in ³
Weight- MPP	15.9 gm	0.034 lb
Weight- High Flux	15.0 gm	0.032 lb
Weight- Kool M μ	11.5 gm	0.025 lb
Area Product	0.467 cm ⁴	0.01119 in ⁴

Winding Turn Length

WINDING FACTOR	LENGTH/TURN	
100% (Unity)	4.29 cm	0.1405 ft
60%	3.67 cm	0.1203 ft
40%	3.07 cm	0.1005 ft
20%	2.80 cm	0.0919 ft
0%	2.70 cm	0.0886 ft

Wound Coil Dimensions

Max. O.D. (u.w.f.)	32.6 mm	1.283 in
Max. HT. (u.w.f.)	19.8 mm	0.778 in

Surface Area

Unwound Core	15.7 cm ²	2.43 in ²
40% Winding Factor	23.8 cm ²	3.69 in ²

AWG Wire Size	Turns (u.w.f.)	Rdc (Ohms, Ω) (u.w.f.)	Single Layer Turns	Single Layer Rdc. (Ohms, Ω)
10	24	0.00339	12	0.00106
11	30	0.00537	14	0.00156
12	38	0.00849	16	0.00226
13	47	0.01334	18	0.0032
14	59	0.0211	21	0.0047
15	74	0.033	24	0.00676
16	93	0.0523	27	0.00961
17	115	0.0814	31	0.0138
18	143	0.1285	35	0.0198
19	178	0.201	39	0.0278
20	222	0.316	44	0.0395
21	278	0.499	50	0.0565
22	343	0.78	56	0.0804
23	427	1.219	63	0.113
24	529	1.91	71	0.161
25	653	2.97	80	0.229
26	817	4.71	89	0.324
27	1029	7.43	99	0.45
28	1262	11.58	111	0.642
29	1543	17.82	124	0.892

* These values are only applicable for MPP Cores.

23.6 mm O.D.

14.4 mm I.D. x 8.89 mm HT.

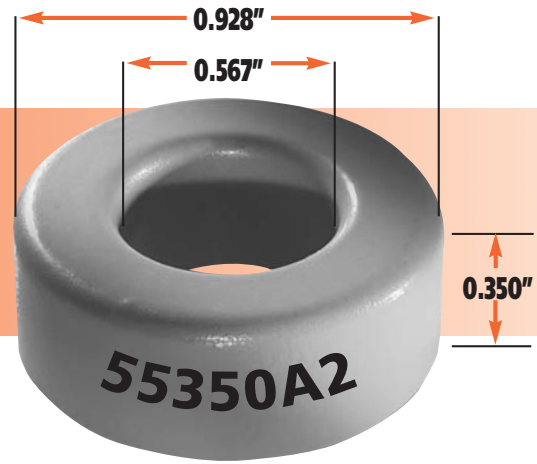

Core Dimensions (after finish)

O.D. (max.)	24.3 mm	0.958 in
I.D. (min.)	13.77 mm	0.542 in
HT. (max.)	9.65 mm	0.380 in

Permeability (μ)	$A_L \pm 8\%$	Part Number			Nominal DC Resistance Ohms/mH*	B/NI Gauss per Amp. Turn*
		MPP	High Flux	Kool M μ		
14	12	55353	58353	-	0.618	5 (<1500 gauss)
26	22	55352	58352	77352	0.337	5.56 (<1500 gauss)
60	51	55351	58351	77351	0.1453	12.8 (< 1500 gauss)
75	63	-	-	77355	-	-
90	76	-	-	77354	-	-
125	105	55350	58350	77350	0.0706	26.8 (<1500 gauss)
160	135	55348	58348	-	0.0549	34.2 (<1500 gauss)
200	169	55347	-	-	0.0438	42.8 (<600 gauss)
300	253	55345	-	-	0.0293	64.2 (<300 gauss)

Physical Characteristics

Window Area	1.49 cm ²	293,800 c.mils
Cross Section	0.388 cm ²	0.061 in ²
Path Length	5.88 cm	2.32 in
Volume	2.28 cm ³	0.142 in ³
Weight- MPP	19.9 gm	0.042 lb
Weight- High Flux	18.8 gm	0.040 lb
Weight- Kool M μ	14.0 gm	0.031 lb
Area Product	0.578 cm ⁴	0.0139 in ⁴

Winding Turn Length

WINDING FACTOR	LENGTH/TURN	
100% (Unity)	4.49 cm	0.1473 ft
60%	3.91 cm	0.1282 ft
40%	3.34 cm	0.1095 ft
20%	3.09 cm	0.1013 ft
0%	3.00 cm	0.0982 ft

Wound Coil Dimensions

Max. O.D. (u.w.f.)	33.5 mm	1.319 in
Max. HT. (u.w.f.)	21.4 mm	0.843 in

Surface Area

Unwound Core	17.9 cm ²	2.78 in ²
40% Winding Factor	26.3 cm ²	4.08 in ²

AWG Wire Size	Turns (u.w.f.)	Rdc (Ohms, Ω) (u.w.f.)	Single Layer Turns	Single Layer Rdc. (Ohms, Ω)
9	20	0.00238	11	0.000853
10	26	0.00376	13	0.00127
11	32	0.00595	15	0.00186
12	40	0.00941	17	0.00265
13	50	0.0148	19	0.00373
14	63	0.0233	22	0.00544
15	78	0.0366	25	0.00781
16	98	0.058	28	0.0111
17	121	0.0903	32	0.0159
18	157	0.1425	36	0.0226
19	188	0.223	40	0.0316
20	235	0.351	46	0.0458
21	294	0.554	51	0.0691
22	363	0.865	58	0.0923
23	452	1.351	65	0.13
24	560	2.12	73	0.184
25	691	3.3	82	0.261
26	864	5.22	92	0.37
27	1088	8.24	102	0.515
28	1335	12.84	114	0.731

Core Data

* These values are only applicable for MPP Cores.



26.9 mm O.D.

14.7 mm I.D. x 11.2 mm HT.

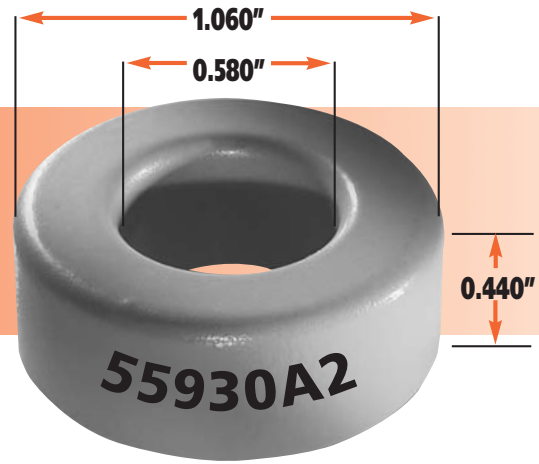

Core Dimensions (after finish)

O.D. (max.)	27.7 mm	1.090 in
I.D. (min.)	14.10 mm	0.555 in
HT. (max.)	11.94 mm	0.470 in

Permeability (μ)	$A_L \pm 8\%$	Part Number			Nominal DC Resistance Ohms/mH*	B/NI Gauss per Amp. Turn*
		MPP	High Flux	Kool M μ		
14	18	55933	58933	-	0.457	2.77 (<1500 gauss)
26	32	55932	58932	77932	0.257	5.15 (<1500 gauss)
60	75	55894	58894	77894	0.110	11.9 (<1500 gauss)
75	94	-	-	77935	-	-
90	113	-	-	77934	-	-
125	157	55930	58930	77930	0.0524	24.8 (<1500 gauss)
160	201	55928	58928	-	0.0409	31.7 (<1500 gauss)
200	251	55927	-	-	0.0327	39.6 (<1500 gauss)
300	377	55925	-	-	0.0218	59.4 (<300 gauss)
550	740	55926	-	-	0.0111	109 (<50 gauss)

Physical Characteristics

Window Area	1.56 cm ²	308,000 c.mils
Cross Section	0.654 cm ²	0.1014 in ²
Path Length	6.35 cm	2.50 in
Volume	4.15 cm ³	0.254 in ³
Weight- MPP	35.8 gm	0.080 lb
Weight- High Flux	33.8 gm	0.075 lb
Weight- Kool M μ	25.5 gm	0.056 lb
Area Product	1.020 cm ⁴	0.0245 in ⁴

Winding Turn Length

WINDING FACTOR	LENGTH/TURN	
100% (Unity)	5.23 cm	0.1714 ft
60%	4.66 cm	0.1526 ft
40%	4.10 cm	0.1344 ft
20%	3.85 cm	0.1263 ft
0%	3.76 cm	0.1233 ft

Wound Coil Dimensions

Max. O.D. (u.w.f.)	37.3 mm	1.468 in
Max. HT. (u.w.f.)	24.0 mm	0.944 in

Surface Area

Uwound Core	24.7 cm ²	3.83 in ²
40% Winding Factor	33.8 cm ²	5.24 in ²

AWG Wire Size	Turns (u.w.f.)	Rdc (Ohms, Ω) (u.w.f.)	Single Layer Turns	Single Layer Rdc. (Ohms, Ω)
9	21	0.00291	11	0.00107
10	27	0.00459	13	0.0016
11	34	0.00726	15	0.00233
12	42	0.01148	17	0.00333
13	53	0.01805	20	0.00494
14	66	0.0284	22	0.00685
15	82	0.0447	25	0.0098
16	103	0.0707	29	0.0144
17	127	0.1102	33	0.0203
18	159	0.1739	37	0.0291
19	197	0.272	42	0.0416
20	246	0.428	47	0.0587
21	308	0.676	53	0.0835
22	380	1.056	60	0.12
23	474	1.649	66	0.165
24	587	2.58	75	0.237
25	725	4.02	84	0.335
26	906	6.37	94	0.476
27	1141	10.05	105	0.744
28	1400	15.67	117	0.942

* These values are only applicable for MPP Cores.

33.0 mm O.D.

19.9 mm I.D. x 10.7 mm HT.

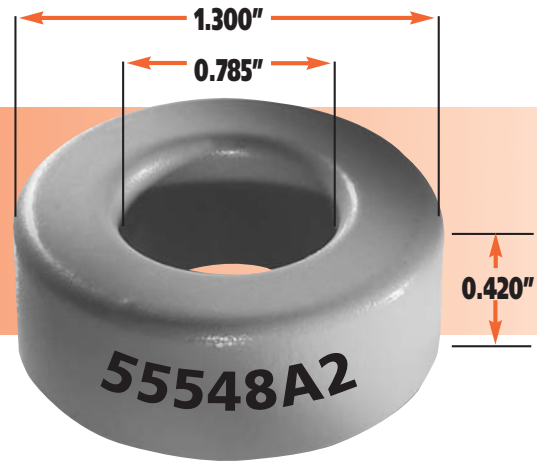

Core Dimensions (after finish)

O.D. (max.)	33.8 mm	1.330 in
I.D. (min.)	19.30 mm	0.760 in
HT. (max.)	11.43 mm	0.450 in

Permeability (μ)	$A_L \pm 8\%$	Part Number			Nominal DC Resistance Ohms/mH*	B/NI Gauss per Amp. Turn*
		MPP	High Flux	Kool M μ		
14	14	55551	58551	-	0.335	2.16 (<1500 gauss)
26	28	55550	58550	77550	0.167	4.00 (<1500 gauss)
60	61	55071	58071	77071	0.0768	9.24 (<1500 gauss)
75	76	-	-	77553	-	-
90	91	-	-	77552	-	-
125	127	55548	58548	77548	0.0369	19.3 (<1500 gauss)
160	163	55546	58546	-	0.0287	24.6 (<1500 gauss)
200	203	55545	-	-	0.0230	30.8 (<600 gauss)
300	305	55543	-	-	0.0153	46.2 (<300 gauss)
550	559	55544	-	-	0.0083	84.7 (<50 gauss)

Physical Characteristics

Window Area	2.93 cm ²	577,600 c.mils
Cross Section	0.672 cm ²	0.1042 in ²
Path Length	8.15 cm	3.21 in
Volume	5.48 cm ³	0.334 in ³
Weight- MPP	46.9 gm	0.106 lb
Weight- High Flux	44.2 gm	0.100 lb
Weight- Kool M μ	33.7 gm	0.074 lb
Area Product	1.969 cm ⁴	0.0473 in ⁴

Winding Turn Length

WINDING FACTOR	LENGTH/TURN	
100% (Unity)	5.93 cm	0.1943 ft
60%	5.09 cm	0.1668 ft
40%	4.27 cm	0.1400 ft
20%	3.91 cm	0.1282 ft
0%	3.78 cm	0.1238 ft

Wound Coil Dimensions

Max. O.D. (u.w.f.)	46.7 mm	1.840 in
Max. HT. (u.w.f.)	28.0 mm	1.103 in

Surface Area

Unwound Core	31.5 cm ²	4.88 in ²
40% Winding Factor	48.0 cm ²	7.44 in ²

AWG Wire Size	Turns (u.w.f.)	Rdc (Ohms, Ω) (u.w.f.)	Single Layer Turns	Single Layer Rdc. (Ohms, Ω)
8	32	0.00393	15	0.00117
9	40	0.00618	17	0.00166
10	50	0.00976	19	0.00236
11	63	0.01544	22	0.00343
12	79	0.0244	25	0.0055
13	99	0.0384	28	0.00693
14	123	0.0604	32	0.00999
15	154	0.0949	36	0.0142
16	193	0.1504	41	0.0204
17	239	0.234	46	0.0288
18	298	0.37	52	0.0411
19	370	0.579	58	0.0578
20	462	0.909	65	0.0815
21	578	1.437	74	0.118
22	713	2.24	83	0.166
23	889	3.5	92	0.231
24	1100	5.49	103	0.328
25	1359	8.56	116	0.465
26	1699	13.53	130	0.66
27	2139	21.4	145	0.922

Core Data

* These values are only applicable for MPP Cores.



34.3 mm O.D.

23.4 mm I.D. x 8.89 mm HT.

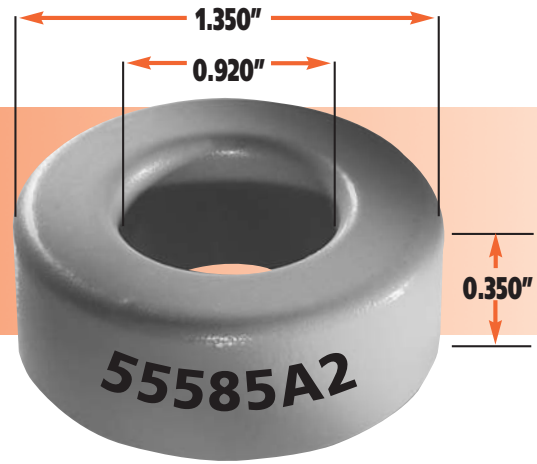

Core Dimensions (after finish)

O.D. (max.)	35.2 mm	1.385 in
I.D. (min.)	22.6 mm	0.888 in
HT. (max.)	9.78 mm	0.385 in

Permeability (μ)	$A_L \pm 8\%$	Part Number			Nominal DC Resistance Ohms/mH*	B/NI Gauss per Amp. Turn*
		MPP	High Flux	Kool M μ		
14	9	55588	58588	-	0.366	1.96 (<1500 gauss)
26	16	55587	58587	77587	0.206	3.64 (<1500 gauss)
60	38	55586	58586	77586	0.0866	8.40 (<1500 gauss)
75	47	-	-	77590	-	-
90	57	-	-	77589	-	-
125	79	55585	58585	77585	0.0417	17.5 (<1500 gauss)
160	101	55583	58583	-	0.0326	24.2 (<1500 gauss)
200	126	55582	-	-	0.0261	28 (<600 gauss)
300	190	55580	-	-	0.0173	42 (<300 gauss)
550	348	55581	-	-	0.0094	77(<50 gauss)

Physical Characteristics

Window Area	4.01 cm ²	788,500 c.mils
Cross Section	0.454 cm ²	0.0704 in ²
Path Length	8.95 cm	3.53 in
Volume	4.06 cm ³	0.249 in ³
Weight- MPP	34.9 gm	0.081 lb
Weight- High Flux	32.9 gm	0.076 lb
Weight- Kool M μ	25.0 gm	0.055 lb
Area Product	1.821 cm ⁴	0.0436 in ⁴

Winding Turn Length

WINDING FACTOR	LENGTH/TURN	
100% (Unity)	5.87 cm	0.1923 ft
60%	4.84 cm	0.1586 ft
40%	3.84 cm	0.1258 ft
20%	3.39 cm	0.1113 ft
0%	3.23 cm	0.1059 ft

Wound Coil Dimensions

Max. O.D. (u.w.f.)	50.1 mm	1.974 in
Max. HT. (u.w.f.)	29.0 mm	1.142 in

Surface Area

Unwound Core	29.3 cm ²	4.537 in ²
40% Winding Factor	51.3 cm ²	7.95 in ²

AWG Wire Size	Turns (u.w.f.)	Rdc (Ohms, Ω) (u.w.f.)	Single Layer Turns	Single Layer Rdc. (Ohms, Ω)
8	44	0.00531	18	0.0012
9	55	0.00835	20	0.00168
10	69	0.01319	23	0.00243
11	86	0.0209	26	0.00348
12	108	0.033	30	0.00505
13	135	0.0518	34	0.0072
14	168	0.0817	38	0.0101
15	210	0.1283	43	0.0145
16	263	0.203	48	0.0205
17	326	0.316	54	0.0288
18	406	0.499	61	0.0413
19	505	0.782	69	0.0665
20	631	1.229	77	0.0826
21	789	1.941	87	0.118
22	974	3.03	98	0.168
23	1213	4.74	109	0.234
24	1502	7.43	122	0.322
25	1855	11.56	137	0.47
26	2319	18.29	153	0.665
27	2921	28.9	170	0.925

* These values are only applicable for MPP Cores.

35.8 mm O.D.

22.4 mm I.D. x 10.5 mm HT.

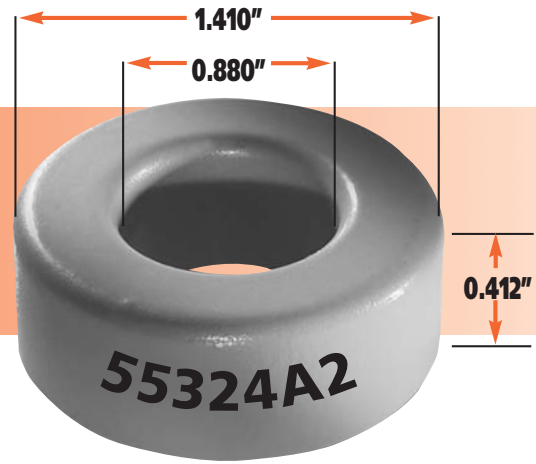

Core Dimensions (after finish)

O.D. (max.)	36.7 mm	1.445 in
I.D. (min.)	21.5 mm	0.848 in
HT. (max.)	11.35 mm	0.447 in

Permeability (μ)	$A_L \pm 8\%$	Part Number			Nominal DC Resistance Ohms/mH*	B/NI Gauss per Amp. Turn*
		MPP	High Flux	Kool M μ		
14	13	55327	58327	-	0.301	1.96 (<1500 gauss)
26	24	55326	58326	77326	0.163	3.64 (<1500 gauss)
60	56	55076	58076	77076	0.0697	8.40 (<1500 gauss)
75	70	-	-	77329	-	-
90	84	-	-	77328	-	-
125	117	55324	58324	77324	0.0334	17.5 (<1500 gauss)
160	150	55322	58322	-	0.026	22.4 (<1500 gauss)
200	187	55321	-	-	0.0208	28 (<600 gauss)
300	281	55319	-	-	0.0139	42 (<300 gauss)
550	515	55320	-	-	0.0075	77 (<50 gauss)

Physical Characteristics

Window Area	3.64 cm ²	719,100 c.mils
Cross Section	0.678 cm ²	0.1051 in ²
Path Length	8.98 cm	3.54 in
Volume	6.088 cm ³	0.372 in ³
Weight- MPP	51.8 gm	0.112 lb
Weight- High Flux	48.9 gm	0.106 lb
Weight- Kool M μ	37.4 gm	0.082 lb
Area Product	2.47 cm ⁴	0.0594 in ⁴

Winding Turn Length

WINDING FACTOR	LENGTH/TURN	
100% (Unity)	6.22 cm	0.2040 ft
60%	5.27 cm	0.1727 ft
40%	4.34 cm	0.1422 ft
20%	3.93 cm	0.1288 ft
0%	3.78 cm	0.1238 ft

Wound Coil Dimensions

Max. O.D. (u.w.f.)	51.1 mm	2.01 in
Max. HT. (u.w.f.)	29.6 mm	1.165 in

Surface Area

Unwound Core	34.5 cm ²	5.35 in ²
40% Winding Factor	55.1 cm ²	8.54 in ²

AWG Wire Size	Turns (u.w.f.)	Rdc (Ohms, Ω) (u.w.f.)	Single Layer Turns	Single Layer Rdc. (Ohms, Ω)
8	40	0.00513	17	0.00133
9	50	0.00807	19	0.00185
10	63	0.01275	22	0.00273
11	79	0.0202	25	0.0039
12	98	0.0319	28	0.00551
13	123	0.0501	32	0.00792
14	154	0.079	36	0.0112
15	191	0.124	41	0.0162
16	240	0.1965	46	0.0229
17	297	0.306	52	0.0325
18	371	0.483	58	0.0458
19	461	0.757	65	0.0648
20	575	1.188	73	0.0915
21	719	1.877	82	0.13
22	888	2.93	93	0.187
23	1106	4.58	103	0.259
24	1370	7.18	116	0.368
25	1692	11.18	130	0.521
26	2115	17.68	146	0.741
27	2663	27.9	161	1.02

Core Data

* These values are only applicable for MPP Cores.



39.9 mm O.D.

24.1 mm I.D. x 14.5 mm HT.

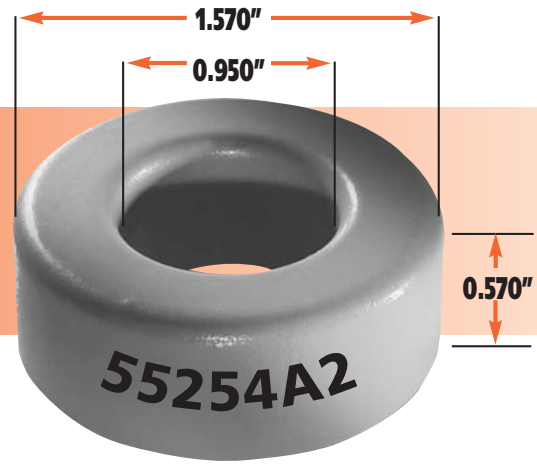

Core Dimensions (after finish)

O.D. (max.)	40.8 mm	1.605 in
I.D. (min.)	23.3 mm	0.918 in
HT. (max.)	15.37 mm	0.605 in

Permeability (μ)	$A_L \pm 8\%$	Part Number			Nominal DC Resistance Ohms/mH*	B/NI Gauss per Amp. Turn*
		MPP	High Flux	Kool M μ		
14	19	55257	58257	-	0.203	1.79 (<1500 gauss)
26	35	55256	58256	77256	0.11	3.33 (<1500 gauss)
60	81	55083	58083	77083	0.0477	7.68 (<1500 gauss)
75	101	-	-	77259	-	-
90	121	-	-	77258	-	-
125	168	55254	58254	77254	0.023	16 (<1500 gauss)
160	215	55252	58252	-	0.0179	20.5 (<1500 gauss)
200	269	55251	-	-	0.0143	25.6 (<600 gauss)
300	403	55249	-	-	0.0095	38.4 (<300 gauss)
550	740	55250	-	-	0.0052	70.4 (<50 gauss)

Physical Characteristics

Window Area	4.27 cm ²	842,700 c.mils
Cross Section	1.072 cm ²	0.1662 in ²
Path Length	9.84 cm	3.88 in
Volume	10.5 cm ³	0.645 in ³
Weight- MPP	91.7 gm	0.206 lb
Weight- High Flux	86.5 gm	0.194 lb
Weight- Kool M μ	64.9 gm	0.143 lb
Area Product	4.58 cm ⁴	0.1100 in ⁴

Winding Turn Length

WINDING FACTOR	LENGTH/TURN	
100% (Unity)	7.38 cm	0.242 ft
60%	6.38 cm	0.209 ft
40%	5.40 cm	0.1772 ft
20%	4.97 cm	0.1631 ft
0%	4.81 cm	0.1578 ft

Wound Coil Dimensions

Max. O.D. (u.w.f.)	56.4 mm	2.22 in
Max. HT. (u.w.f.)	35.2 mm	1.385 in

Surface Area

Unwound Core	48.4 cm ²	7.5 in ²
40% Winding Factor	71.7 cm ²	11.1 in ²

AWG Wire Size	Turns (u.w.f.)	Rdc (Ohms, Ω) (u.w.f.)	Single Layer Turns	Single Layer Rdc. (Ohms, Ω)
8	47	0.00714	18	0.00179
9	59	0.01123	21	0.00263
10	73	0.01774	24	0.00378
11	92	0.0281	27	0.00537
12	115	0.0444	31	0.00778
13	144	0.0698	35	0.0111
14	180	0.1099	39	0.0155
15	224	0.1726	44	0.0221
16	281	0.273	50	0.0317
17	348	0.426	56	0.0446
18	434	0.672	63	0.0636
19	540	1.053	71	0.0902
20	674	1.653	80	0.128
21	843	2.61	90	0.182
22	1040	4.08	101	0.259
23	1297	6.37	112	0.359
24	1605	9.99	126	0.511
25	1983	15.55	141	0.721
26	2479	24.6	158	1.02
27	3121	38.8	175	1.42

* These values are only applicable for MPP Cores.

46.7 mm O.D.

24.1 mm I.D. x 18.0 mm HT.

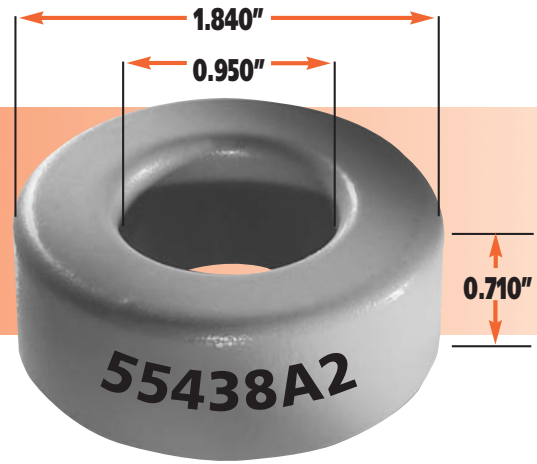

Core Dimensions (after finish)

O.D. (max.)	47.6 mm	1.875 in
I.D. (min.)	23.3 mm	0.918 in
HT. (max.)	18.92 mm	0.745 in

Permeability (μ)	$A_L \pm 8\%$	Part Number			Nominal DC Resistance Ohms/mH*	B/NI Gauss per Amp. Turn*
		MPP	High Flux	Kool μ		
14	32	55441	58441	-	0.141	1.64 (<1500 gauss)
26	59	55440	58440	77440	0.0766	3.04 (<1500 gauss)
60	135	55439	58439	77439	0.0335	7.02 (<1500 gauss)
75	169	-	-	77443	-	-
90	202	-	-	77442	-	-
125	281	55438	58438	77438	0.0161	14.6 (<1500 gauss)
160	360	55436	-	-	0.0125	18.7 (<1500 gauss)
200	450	55435	-	-	0.0100	23.4 (<600 gauss)
300	674	55433	-	-	0.0067	35.1 (<300 gauss)

Physical Characteristics

Window Area	4.27 cm ²	842,700 c.mils
Cross Section	1.990 cm ²	0.308 in ²
Path Length	10.74 cm	4.23 in
Volume	21.3 cm ³	1.30 in ³
Weight- MPP	181 gm	0.399 lb
Weight- High Flux	171 gm	0.378 lb
Weight- Kool μ	131.4 gm	0.29 lb
Area Product	8.50 cm ⁴	0.204 in ⁴

Winding Turn Length

WINDING FACTOR	LENGTH/TURN	
100% (Unity)	8.66 cm	0.284 ft
60%	7.71 cm	0.253 ft
40%	6.78 cm	0.222 ft
20%	6.37 cm	0.209 ft
0%	6.22 cm	0.204 ft

Wound Coil Dimensions

Max. O.D. (u.w.f.)	63.8 mm	2.51 in
Max. HT. (u.w.f.)	38.7 mm	1.525 in

Surface Area

Unwound Core	69.3 cm ²	10.7 in ²
40% Winding Factor	94.3 cm ²	14.6 in ²

AWG Wire Size	Turns (u.w.f.)	Rdc (Ohms, Ω) (u.w.f.)	Single Layer Turns	Single Layer Rdc. (Ohms, Ω)
8	47	0.00837	18	0.00231
9	59	0.01317	21	0.00339
10	73	0.0208	24	0.0049
11	92	0.0329	27	0.00694
12	115	0.052	31	0.01
13	144	0.0818	35	0.0143
14	180	0.1288	39	0.0201
15	224	0.202	44	0.0285
16	281	0.32	50	0.041
17	348	0.499	56	0.0577
18	434	0.788	63	0.0821
19	540	1.234	71	0.116
20	674	1.938	80	0.166
21	843	3.06	90	0.236
22	1040	4.78	101	0.334
23	1297	7.47	112	0.464
24	1605	11.71	126	0.66
25	1983	18.23	141	0.932
26	2479	28.8	158	1.32
27	3121	45.5	175	1.83

Core Data

* These values are only applicable for MPP Cores.



46.7 mm O.D.

28.7 mm I.D. x 15.2 mm HT.

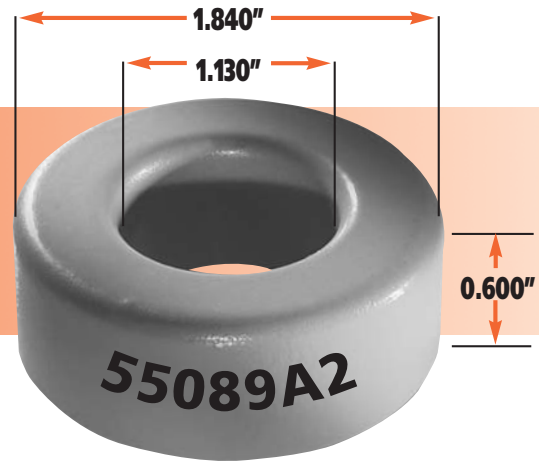

Core Dimensions (after finish)

O.D. (max.)	47.6 mm	1.875 in
I.D. (min.)	27.9 mm	1.098 in
HT. (max.)	16.13 mm	0.635 in

Permeability (μ)	$A_L \pm 8\%$	Part Number			Nominal DC Resistance Ohms/mH*	B/NI Gauss per Amp. Turn*
		MPP	High Flux	Kool M μ		
14	20	55092	58092	-	0.149	1.51 (<1500 gauss)
26	37	55091	58091	77091	0.0803	2.81 (<1500 gauss)
60	86	55090	58090	77090	0.0345	6.48 (<1500 gauss)
75	107	-	-	77094	-	-
90	128	-	-	77093	-	-
125	178	55089	58089	77089	0.0167	13.5 (<1500 gauss)
160	228	55087	-	-	0.013	17.3 (<1500 gauss)
200	285	55086	-	-	0.0104	21.6 (<600 gauss)
300	427	55084	-	-	0.0069	32.4 (<300 gauss)

Physical Characteristics

Window Area	6.11 cm ²	1,206,000 c.mils
Cross Section	1.340 cm ²	0.208 in ²
Path Length	11.63 cm	4.58 in
Volume	15.58 cm ³	0.953 in ³
Weight- MPP	130.4 gm	0.287 lb
Weight- High Flux	123 gm	0.271 lb
Weight- Kool M μ	95.8 gm	0.211 lb
Area Product	8.19 cm ⁴	0.1971 in ⁴

Winding Turn Length

WINDING FACTOR	LENGTH/TURN	
100% (Unity)	8.34 cm	0.273 ft
60%	7.12 cm	0.233 ft
40%	5.92 cm	0.194 ft
20%	5.40 cm	0.177 ft
0%	5.20 cm	0.171 ft

Wound Coil Dimensions

Max. O.D. (u.w.f.)	66.3 mm	2.61 in
Max. HT. (u.w.f.)	39.8 mm	1.568 in

Surface Area

Unwound Core	61.7 cm ²	9.56 in ²
40% Winding Factor	95.1 cm ²	14.74 in ²

AWG Wire Size	Turns (u.w.f.)	Rdc (Ohms, Ω) (u.w.f.)	Single Layer Turns	Single Layer Rdc. (Ohms, Ω)
8	67	0.01153	23	0.00247
9	84	0.01814	26	0.0035
10	105	0.0287	29	0.00494
11	132	0.0453	33	0.00709
12	165	0.0717	37	0.01
13	206	0.1127	42	0.0143
14	258	0.1774	47	0.0202
15	321	0.279	54	0.0293
16	402	0.442	60	0.0411
17	498	0.688	68	0.0664
18	621	1.085	76	0.0828
19	773	1.7	86	0.118
20	964	2.67	96	0.166
21	1206	4.22	108	0.236
22	1488	6.59	121	0.335
23	1855	10.29	135	0.468
24	2296	16.13	152	0.666
25	2837	25.1	170	0.939
26	3546	39.7	190	1.33
27	4465	62.7	211	1.86

* These values are only applicable for MPP Cores.

50.8 mm O.D.

31.8 mm I.D. x 13.5 mm HT.

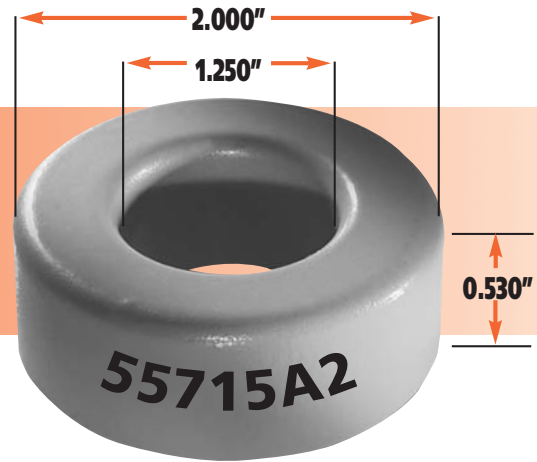

Core Dimensions (after finish)

O.D. (max.)	51.7 mm	2.035 in
I.D. (min.)	30.9 mm	1.218 in
HT. (max.)	14.35 mm	0.565 in

Permeability (μ)	$A_L \pm 8\%$	Part Number			Nominal DC Resistance Ohms/mH*	B/NI Gauss per Amp. Turn*
		MPP	High Flux	Kool M μ		
14	17	55718	58718	-	0.141	1.39 (<1500 gauss)
26	32	55717	58717	77717	0.075	2.57(<1500 gauss)
60	73	55716	58716	77716	0.0328	5.94 (<1500 gauss)
75	91	-	-	77720	-	-
90	109	-	-	77719	-	-
125	152	55715	58715	77715	0.0158	12.4 (<1500 gauss)
160	195	55713	-	-	0.0123	15.8 (<1500 gauss)
200	243	55712	-	-	0.0098	19.8 (<600 gauss)
300	365	55710	-	-	0.0065	29.7 (<300 gauss)

Physical Characteristics

Window Area	7.50 cm ²	1,484,000 c.mils
Cross Section	1.251 cm ²	0.194 in ²
Path Length	12.73 cm	5.02 in
Volume	15.93 cm ³	0.974 in ³
Weight- MPP	141 gm	0.312 lb
Weight- High Flux	133 gm	0.294 lb
Weight- Kool M μ	98.1 gm	0.216 lb
Area Product	9.38 cm ⁴	0.226 in ⁴

Winding Turn Length

WINDING FACTOR	LENGTH/TURN	
100% (Unity)	8.51 cm	0.279 ft
60%	7.12 cm	0.234 ft
40%	5.77 cm	0.189 ft
20%	5.18 cm	0.170 ft
0%	4.95 cm	0.162 ft

Wound Coil Dimensions

Max. O.D. (u.w.f.)	72.4 mm	2.85 in
Max. HT. (u.w.f.)	40.6 mm	1.600 in

Surface Area

Unwound Core	64.2 cm ²	9.95 in ²
40% Winding Factor	106.3 cm ²	16.48 in ²

AWG Wire Size	Turns (u.w.f.)	Rdc (Ohms, Ω) (u.w.f.)	Single Layer Turns	Single Layer Rdc. (Ohms, Ω)
8	82	0.0144	25	0.0025
9	103	0.0228	29	0.00369
10	129	0.036	33	0.00533
11	162	0.0569	37	0.00752
12	203	0.09	42	0.0108
13	254	0.1415	47	0.0153
14	317	0.223	53	0.0217
15	395	0.35	60	0.031
16	495	0.555	67	0.0437
17	613	0.864	76	0.0622
18	765	1.363	85	0.0882
19	951	2.14	95	0.121
20	1187	3.35	107	0.176
21	1484	5.3	120	0.25
22	1832	8.28	135	0.354
23	2282	12.93	150	0.494
24	2826	20.3	168	0.701
25	3491	31.6	188	0.989
26	4363	49.9	211	1.4
27	5495	78.8	234	1.95

Core Data

* These values are only applicable for MPP Cores.



57.2 mm O.D.

26.4 mm I.D. x 15.2 mm HT.

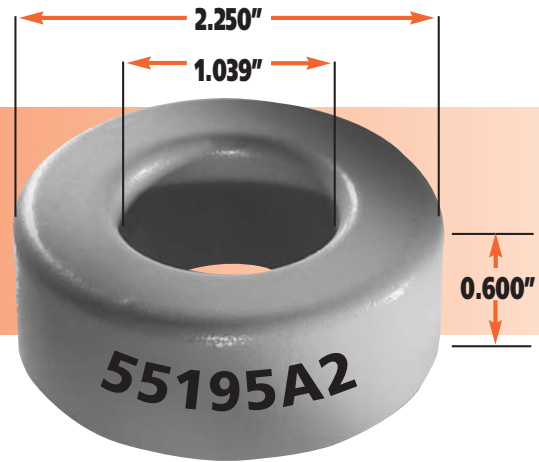

Core Dimensions (after finish)

O.D. (max.)	58.0 mm	2.285 in
I.D. (min.)	25.6 mm	1.007 in
HT. (max.)	16.1 mm	0.635 in

Permeability (μ)	$A_L \pm 8\%$	Part Number			Nominal DC Resistance Ohms/mH*	B/NI Gauss per Amp. Turn*
		MPP	High Flux	Kool M μ		
14	32	55190	58190	-	-	-
26	60	55191	58191	77191	-	-
60	138	55192	58192	77192	-	-
75	172	-	-	77193	-	-
90	207	-	-	77194	-	-
125	287	55195	58195	77195	-	-
160	333	55197	-	-	-	-
200	417	55199	-	-	-	-

Physical Characteristics

Window Area	5.14 cm ²	1,014,049 c.mils
Cross Section	2.29 cm ²	0.355 in ²
Path Length	12.5 cm	4.93 in
Volume	28.6 cm ³	1.75 in ³
Weight- MPP	240 gm	0.527 lb
Weight- High Flux	226 gm	0.497 lb
Weight- Kool M μ	176 gm	0.388 lb
Area Product	11.8 cm ⁴	0.283 in ⁴

Winding Turn Length

WINDING FACTOR	LENGTH/TURN	
100% (Unity)	9.02 cm	0.296 ft
60%	8.35 cm	0.274 ft
40%	7.62 cm	0.250 ft
20%	7.01 cm	0.230 ft
0%	6.46 cm	0.212 ft

Wound Coil Dimensions

Max. O.D. (u.w.f.)	75.7 mm	2.98 in
Max. HT. (u.w.f.)	34.0 mm	1.34 in

Surface Area

Unwound Core	91.0 cm ²	14.1 in ²
40% Winding Factor	115 cm ²	17.8 in ²

AWG Wire Size	Turns (u.w.f.)	Rdc (Ohms, Ω) (u.w.f.)	Single Layer Turns	Single Layer Rdc. (Ohms, Ω)
8	56	0.00967	20	0.00267
9	70	0.0151	23	0.00385
10	88	0.0241	26	0.00551
11	110	0.0379	30	0.00801
12	138	0.0601	34	0.0115
13	173	0.0948	39	0.0165
14	216	0.149	43	0.023
15	269	0.234	49	0.033
16	338	0.372	55	0.0469
17	419	0.58	62	0.0664
18	522	0.914	70	0.0948
19	650	1.43	78	0.133
20	811	2.25	88	0.189
21	1014	3.55	99	0.269
22	1252	5.55	111	0.381
23	1560	8.67	124	0.534
24	1931	13.6	138	0.752
25	2386	21.2	156	1.07
26	2982	33.5	174	1.51
27	3755	52.9	193	2.10

* These values are only applicable for MPP Cores.

57.2 mm

35.6 mm I.D. x 14.0 mm HT.

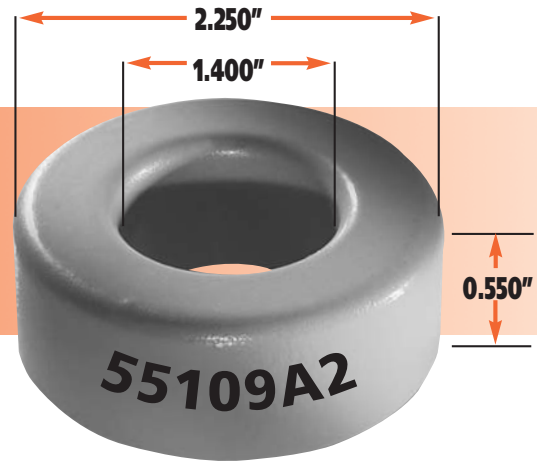

Core Dimensions (after finish)

O.D. (max.)	58.0 mm	2.285 in
I.D. (min.)	34.7 mm	1.368 in
HT. (max.)	14.86 mm	0.585 in

Permeability (μ)	$A_L \pm 8\%$	Part Number			Nominal DC Resistance Ohms/mH*	B/NI Gauss per Amp. Turn*
		MPP	High Flux	Kool M μ		
14	18	55112	58112	-	0.114	1.23 (<1500 gauss)
26	33	55111	58111	77111	0.0624	2.29 (<1500 gauss)
60	75	55110	58110	77110	0.0274	5.28 (<1500 gauss)
75	94	-	-	77214	-	-
90	112	-	-	77213	-	-
125	156	55109	58109	77109	0.0132	11 (<1500 gauss)
160	200	55107	-	-	0.0102	14.1 (<1500 gauss)
200	250	55106	-	-	0.0082	17.6 (<600 gauss)
300	374	55104	-	-	0.0055	26.4 (<300 gauss)

Physical Characteristics

Window Area	9.48 cm ²	1,871,000 c.mils
Cross Section	1.444 cm ²	0.224 in ²
Path Length	14.30 cm	5.63 in
Volume	20.65 cm ³	1.260 in ³
Weight- MPP	175 gm	0.387 lb
Weight- High Flux	165 gm	0.365 lb
Weight- Kool M μ	127 gm	0.280 lb
Area Product	13.69 cm ⁴	0.329 in ⁴

Winding Turn Length

WINDING FACTOR	LENGTH/TURN	
100% (Unity)	9.33 cm	0.306 ft
60%	7.76 cm	0.254 ft
40%	6.23 cm	0.204 ft
20%	5.56 cm	0.182 ft
0%	5.30 cm	0.174 ft

Wound Coil Dimensions

Max. O.D. (u.w.f.)	81.3 mm	3.20 in
Max. HT. (u.w.f.)	44.4 mm	1.748 in

Surface Area

Unwound Core	76.8 cm ²	11.9 in ²
40% Winding Factor	130.7 cm ²	20.26 in ²

AWG Wire Size	Turns (u.w.f.)	Rdc (Ohms, Ω) (u.w.f.)	Single Layer Turns	Single Layer Rdc. (Ohms, Ω)
8	104	0.02	29	0.00318
9	130	0.0315	33	0.00453
10	163	0.0498	37	0.00644
11	204	0.0787	42	0.0092
12	256	0.1245	48	0.0133
13	320	0.1957	54	0.0188
14	400	0.308	60	0.0263
15	498	0.484	68	0.0376
16	624	0.767	76	0.0531
17	773	1.195	85	0.0746
18	965	1.886	96	0.107
19	1200	2.95	108	0.152
20	1497	4.64	120	0.211
21	1871	7.33	135	0.3
22	2310	11.45	152	0.428
23	2879	17.88	169	0.596
24	3565	28	189	0.845
25	4403	43.6	212	1.19
26	5504	69	237	1.69
27	6931	109	263	2.35

Core Data

* These values are only applicable for MPP Cores.



77.8 mm O.D.

49.2 mm I.D. x 12.7 mm HT.

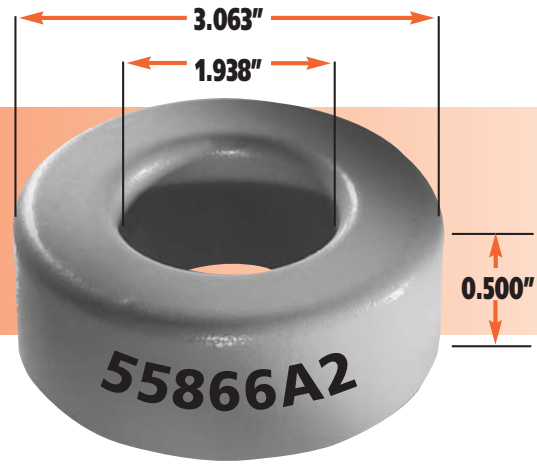

Core Dimensions (after finish)

O.D. (max.)	78.9 mm	3.108 in
I.D. (min.)	48.2 mm	1.898 in
HT. (max.)	13.84 mm	0.545 in

Permeability (μ)	$A_L \pm 8\%$	Part Number			Nominal DC Resistance Ohms/mH*	B/NI Gauss per Amp. Turn*
		MPP	High Flux	Kool M μ		
14	16	55869	58869	-	0.0723	.88 (<1500 gauss)
26	30	55868	58868	77868	0.0386	1.63 (<1500 gauss)
60	68	55867	58867	-	0.017	3.77 (<1500 gauss)
125	142	55866	58866	-	0.0081	7.85 (<1500 gauss)

Physical Characteristics

Window Area	17.99 cm ²	3,550,000 c.mils
Cross Section	1.77 cm ²	0.274 in ²
Path Length	20.0 cm	7.72 in
Volume	34.7 cm ³	2.115 in ³
Weight- MPP	288 gm	0.635 lb
Weight- High Flux	272 gm	0.599 lb
Weight- Kool M μ	213 gm	0.467 lb
Area Product	31.8 cm ⁴	0.765 in ⁴

Winding Turn Length

WINDING FACTOR	LENGTH/TURN	
100% (Unity)	10.40 cm	0.340 ft
60%	8.60 cm	0.282 ft
40%	6.90 cm	0.226 ft
20%	6.15 cm	0.202 ft
0%	5.90 cm	0.193 ft

Wound Coil Dimensions

Max. O.D. (u.w.f.)	112 mm	4.40 in
Max. HT. (u.w.f.)	54.3 mm	2.14 in

Surface Area

Unwound Core	117.5 cm ²	18.2 in ²
40% Winding Factor	203.1 cm ²	31.49 in ²

AWG Wire Size	Turns (u.w.f.)	Rdc (Ohms, Ω) (u.w.f.)	Single Layer Turns	Single Layer Rdc. (Ohms, Ω)
8	197	0.0422	41	0.00552
9	248	0.0664	47	0.00794
10	309	0.105	53	0.0113
11	388	0.1663	60	0.0162
12	486	0.262	67	0.0228
13	608	0.412	76	0.0325
14	760	0.65	84	0.0454
15	944	1.022	95	0.0646
16	1182	1.616	106	0.0912
17	1465	2.52	119	0.129
18	1830	3.98	134	0.183
19	2275	6.23	150	0.258
20	2840	9.8	168	0.364
21	3550	15.45	188	0.514
22	4390	24.2	211	0.732
23	5470	37.4	235	1.02
24	6770	59.2	263	1.3
25	8350	92	295	1.84
26	10450	145.8	330	2.61
27	13150	229	365	3.62

* These values are only applicable for MPP Cores.

77.8 mm O.D.

49.2 mm I.D. x 15.9 mm HT.

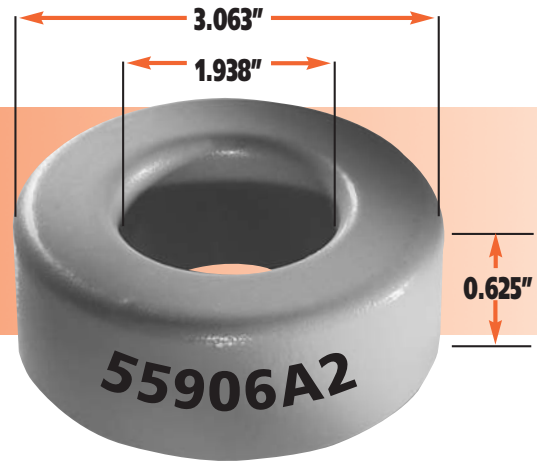

Core Dimensions (after finish)

O.D. (max.)	78.9 mm	3.108 in
I.D. (min.)	48.2 mm	1.898 in
HT. (max.)	17.02 mm	0.670 in

Permeability (μ)	$A_L \pm 8\%$	Part Number			Nominal DC Resistance Ohms/mH*	B/NI Gauss per Amp. Turn*
		MPP	High Flux	Kool μ		
14	20	55909	58909	-	-	-
26	37	55908	58908	77908	-	-
60	85	55907	58907	-	-	-
125	178	55906	58906	-	-	-

Physical Characteristics

Window Area	17.99 cm ²	3,550,000 c.mils
Cross Section	2.27 cm ²	0.352 in ²
Path Length	19.95 cm	7.86 in
Volume	45.3 cm ³	2.77 in ³
Weight- MPP	377 gm	0.832 lb
Weight- High Flux	356 gm	0.785 lb
Weight- Kool μ	279 gm	0.615 lb
Area Product	40.8 cm ⁴	0.982 in ⁴

Winding Turn Length

WINDING FACTOR	LENGTH/TURN	
100% (Unity)	11.00 cm	0.361 ft
60%	9.24 cm	0.303 ft
40%	7.53 cm	0.247 ft
20%	6.80 cm	0.223 ft
0%	6.52 cm	0.214 ft

Wound Coil Dimensions

Max. O.D. (u.w.f.)	113 mm	4.45 in
Max. HT. (u.w.f.)	57.7 mm	2.27 in

Surface Area

Unwound Core	130 cm ²	20.1 in ²
40% Winding Factor	225.2 cm ²	34.90 in ²

AWG Wire Size	Turns (u.w.f.)	Rdc (Ohms, Ω) (u.w.f.)	Single Layer Turns	Single Layer Rdc. (Ohms, Ω)
8	197	0.0418	41	0.00612
9	248	0.0705	47	0.0088
10	309	0.1115	53	0.0125
11	388	0.1766	60	0.018
12	486	0.278	67	0.0253
13	608	0.437	76	0.036
14	760	0.69	84	0.0503
15	944	1.085	95	0.0716
16	1182	1.716	106	0.101
17	1465	2.67	119	0.143
18	1830	4.23	134	0.203
19	2275	6.61	150	0.286
20	2840	10.4	168	0.404
21	3550	16.4	188	0.57
22	4390	25.7	211	0.812
23	5470	39.7	235	1.13
24	6770	62.9	263	1.44
25	8350	97.7	295	2.04
26	10450	154.8	330	2.89
27	13150	243.1	365	4.01

Core Data

* These values are only applicable for MPP Cores.



Kool M μ [®] E Core Data

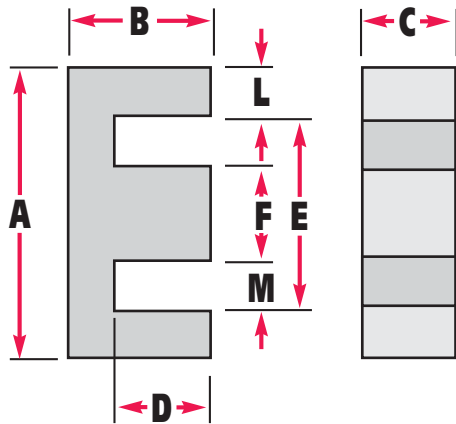

PART NO.		A	B	C	D (min.)	E (min.)	F	L (nom.)	M (min.)
00K1207E (EF 12.6)	in (mm)	.500±.010 (12.70)	.252±.004 (6.40)	.140±.006 (3.56)	0.178 (4.42)	0.35 (8.89)	.140±.005 (3.56)	0.07 (1.78)	0.104 (2.64)
00K1808E (EI-187)	in (mm)	.760±.012 (19.30)	.319±.007 (8.10)	.188±.006 (4.78)	0.218 (5.54)	0.548 (13.90)	.188±.005 (4.78)	0.094 (2.39)	0.183 (4.65)
00K2510E (E-2425)	in (mm)	1.000±.015 (25.40)	.375±.007 (9.53)	.250±.004 (6.53)	0.245 (6.22)	0.74 (18.80)	.250±.005 (6.22)	0.125 (3.17)	0.246 (6.25)
00K3007E (DIN 30/7)	in (mm)	1.185±.018 (30.10)	.591±.009 (15.01)	.278±.006 (7.06)	0.376 (9.70)	0.768 (19.50)	.274±.008 (6.96)	0.201 (5.11)	0.254 (6.46)
00K3515E (EI-375)	in (mm)	1.360±.020 (34.54)	.557±.009 (14.10)	.368±.007 (9.35)	0.378 (9.65)	0.995 (25.30)	.367±.008 (9.32)	0.175 (4.45)	0.31 (7.87)
00K4017E (EE 42/11)	in (mm)	1.687±.025 (42.80)	.830±.013 (21.10)	.424±.010 (10.80)	0.587 (15.00)	1.195 (30.40)	.468±.010 (11.90)	0.234 (5.95)	0.365 (9.27)
00K4020E (DIN 42/15)	in (mm)	1.687±.025 (42.80)	.830±.013 (21.10)	.608±.010 (15.40)	0.587 (15.00)	1.195 (30.40)	.468±.010 (11.90)	0.234 (5.95)	0.365 (9.27)
00K4022E (DIN 42/20)	in (mm)	1.687±.025 (42.80)	.830±.013 (21.10)	.788±.010 (20.00)	0.587 (15.00)	1.195 (30.40)	.468±.010 (11.90)	0.234 (5.95)	0.365 (9.27)
00K4317E (EI-21)	in (mm)	1.609±.024 (40.90)	.650±.011 (16.50)	.493±.007 (12.50)	0.409 (10.40)	1.115 (28.30)	.493±.008 (12.50)	0.238 (6.00)	0.31 (7.90)
00K5528E (DIN 55/21)	in (mm)	2.16±.032 (54.90)	1.085±.016 (27.60)	.812±.015 (20.60)	0.729 (18.50)	1.476 (37.50)	.660±.015 (16.80)	0.33 (8.38)	0.405 (10.30)
00K5530E (DIN 55/25)	in (mm)	2.16±.032 (54.90)	1.085±.016 (27.60)	.969±.015 (24.61)	0.729 (18.50)	1.476 (37.50)	.660±.015 (16.80)	0.33 (8.38)	0.405 (10.30)
00K6527E (Metric E65)	in (mm)	2.563±.050 (65.10)	1.279±.150 (32.50)	1.063±.016 (27.00)	.874 (22.20)	1.740 (44.20)	.775±.012 (19.70)	.394 (10.00)	.476 (12.10)
00K7228E (F11)	in (mm)	2.850±.043 (72.39)	1.100±.020 (27.94)	.750±.015 (19.05)	0.699 (17.78)	2.072 (52.63)	.750±.015 (19.05)	0.375 (9.52)	0.665 (16.89)
00K8020E (Metric E80)	in (mm)	3.150±.047 (80.01)	1.500±.025 (38.10)	.780±.015 (19.81)	1.103 (28.14)	2.334 (59.28)	.780±.015 (19.81)	0.39 (9.91)	0.78 (19.81)

PART NO.	A_L mH/1000 TURNS \pm 8%				Path Length l_e (cm)	Cross Section A_e (cm 2)	Volume V_e (cm 3)
	26 μ	40 μ	60 μ	90 μ			
00K1207E***	-	-	-	-	2.96	0.130	0.385
00K1808E***	26	35	48	69	4.01	0.228	0.914
00K2510E***	39	52	70	100	4.85	0.385	1.87
00K3007E***	33	46	71	92	6.56	0.601	3.94
00K3515E***	56	75	102	146	6.94	0.840	5.83
00K4017E***	56	76	105	151	9.84	1.28	12.6
00K4020E***	80	108	150	217	9.84	1.83	18.0
00K4022E***	104	140	194	281	9.84	2.37	23.3
00K4317E***	88	119	163	234	7.75	1.52	11.8
00K5528E***	116	157	219	NA	12.3	3.50	43.1
00K5530E***	138	187	261	NA	12.3	4.17	51.4
00K6527E***	-	-	-	NA	14.7	5.40	79.4
00K7228E***	-	-	-	NA	13.7	3.68	50.3
00K8020E***	103	145	190	NA	18.5	3.89	72.1

*** Add material code to part number, e.g., for 60 μ the complete part number is 00K1808E060

Kool M μ [®] E Core DC Bias

Kool M μ E cores are available in four permeabilities, 26 μ , 40 μ , 60 μ , and 90 μ . The magnetic data for each core is shown in the table above. The most critical parameter of a switching regulator inductor material is its ability to provide inductance, or permeability, under DC bias. The graph below shows the reduction of permeability as a function of DC bias. The distributed air gap of Kool M μ results in a soft inductance versus DC bias curve. In most

applications, this swinging inductance is desirable since it improves efficiency and accommodates a wide operating range. With a fixed current requirement, the soft inductance versus DC bias curve provides added protection against overload conditions. The chart below is plotted on a semi-log scale to show the DC bias characteristics at high currents.

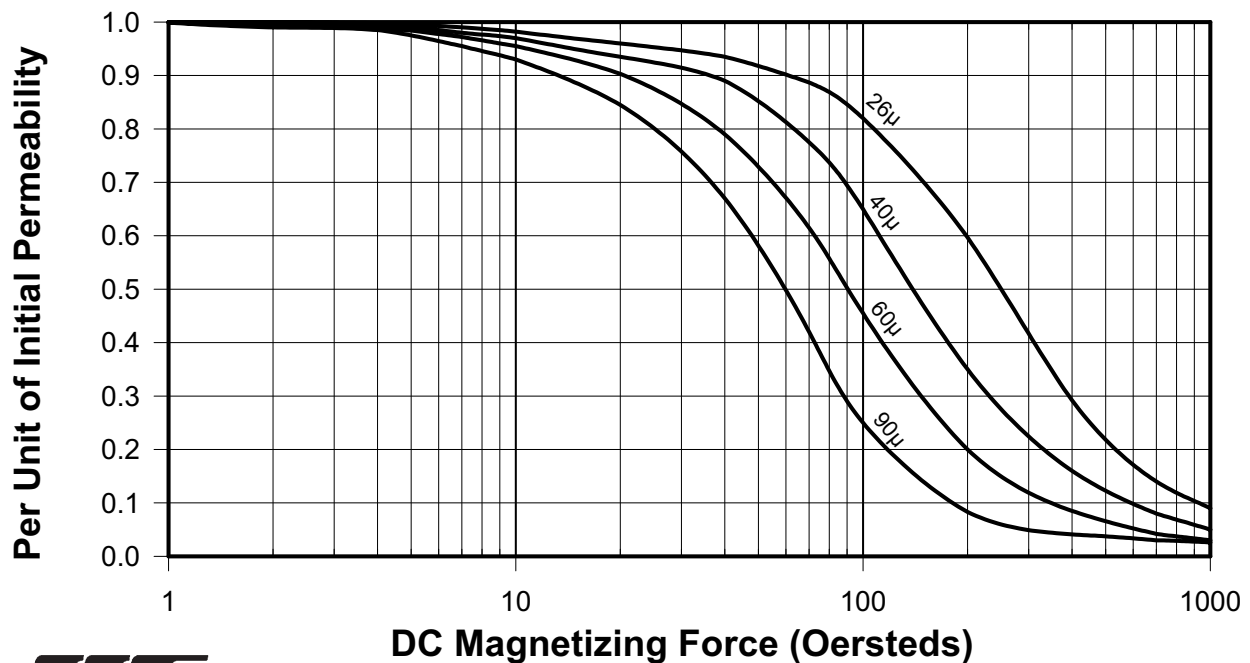

MPP THINZ™ Core Data

Special core heights are available, consult factory.

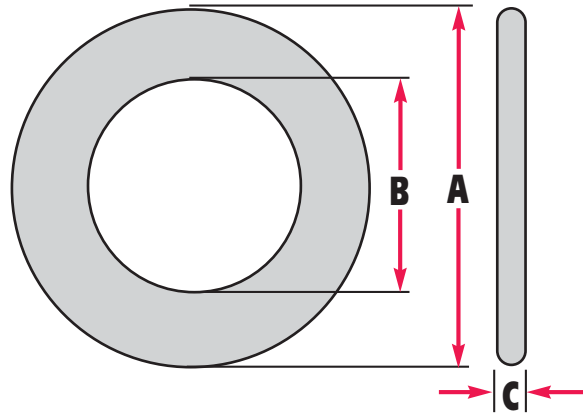

PART NO.		A nom.	B nom.	C nom.	A max.	B min.	C max.
00M0301T	in (mm)	.120 (3.05)	.070 (1.78)	.032 (.81)	.123 (3.12)	.067 (1.70)	.035 (.89)
00M0302T	in (mm)	.140 (3.55)	.070 (1.78)	.032 (.81)	.143 (3.63)	.067 (1.70)	.035 (.89)
00M0402T	in (mm)	.155 (3.94)	.088 (2.23)	.032 (.81)	.159 (4.04)	.084 (2.13)	.035 (.89)
00M0502T	in (mm)	.181 (4.60)	.093 (2.36)	.032 (.81)	.185 (4.70)	.089 (2.26)	.035 (.89)
00M0603T	in (mm)	.250 (6.35)	.110 (2.79)	.032 (.81)	.255 (6.47)	.105 (2.67)	.035 (.89)
00M0804T	in (mm)	.310 (7.87)	.156 (3.96)	.032 (.81)	.315 (8.00)	.151 (3.83)	.035 (.89)

PART NO.	A _e mH/1000 TURNS±15%				Path Length l _e (cm)	Cross Section A _e (cm ²)	Volume V _e (cm ³)
	125μ	160μ	200μ	250μ			
00M0301T***	8.4	10.8	13.5	16.9	.704	.0040	.0028
00M0302T***	11.6	14.8	18.7	23.4	.806	.0060	.0048
00M0402T***	9.6	12.3	15.4	19.3	.944	.0058	.0055
00M0502T***	11.7	15.0	18.7	23.4	1.058	.0079	.0083
00M0603T***	14.9	19.1	24.0	30.0	1.361	.0130	.0177
00M0804T***	12.6	16.2	20.2	25.3	1.789	.0145	.0259

*** Add material code to part number, e.g., for 125μ the complete part number is 00M0502T125

MPP THINZ™ DC Bias

THINZ™ are available in four permeabilities, 125μ, 160μ, 200μ, and 250μ. The most critical parameter of a power inductor material is its ability to provide inductance, or permeability, under DC bias. The distributed air gap of MPP results in a soft inductance versus DC bias curve. This swinging inductance is often desirable since it improves efficiency and accommodates a wide operating range. With a fixed current requirement, the soft

inductance versus DC bias curve provides added protection against overload conditions. With a variable current requirement a more efficient inductor is achieved. The graph below shows the reduction of permeability as a function of DC bias. This graph is plotted on a semi-log scale to show the DC bias characteristics at high DC magnetizing forces. The following equation can be used to relate current to magnetizing force, or H.

$$H = .4 \pi N I / l_e$$

where:

H = DC Magnetizing force in Oersteds

N = number of turns

I = current in amps

l_e = magnetic path length in cm

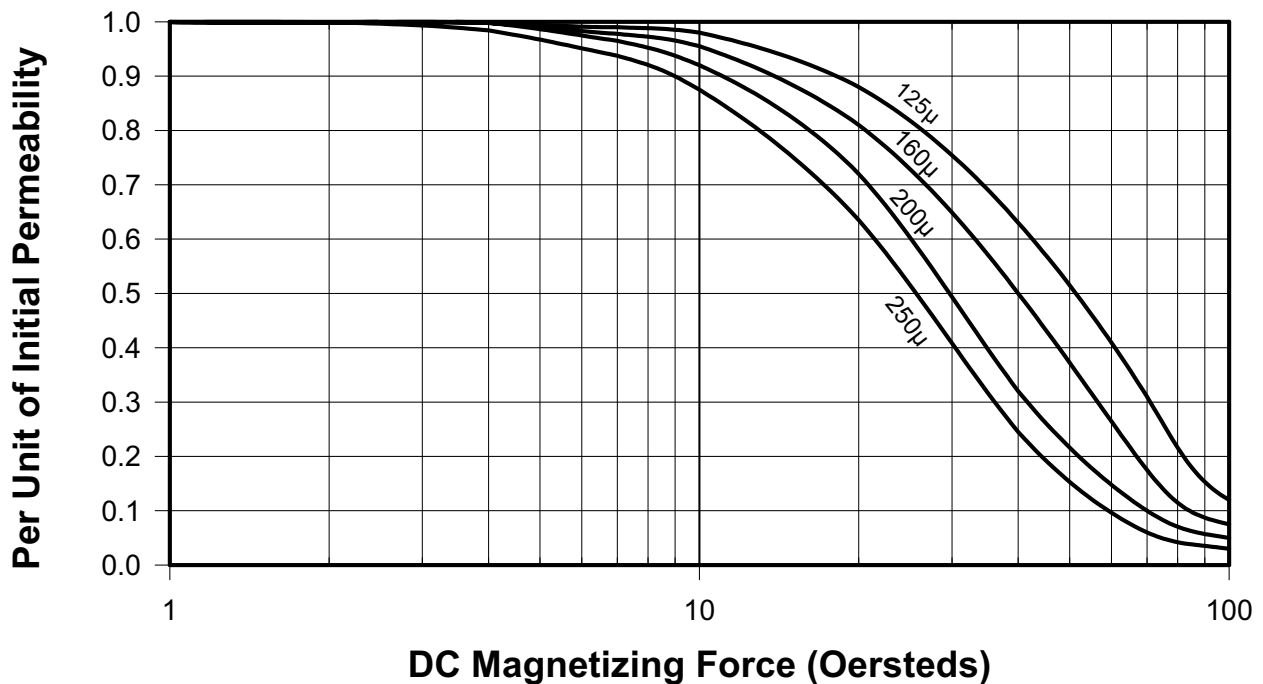

Hardware

TVB22066A

Usable with toroids from 12.7 mm (0.500") through 22.2 mm (0.875")

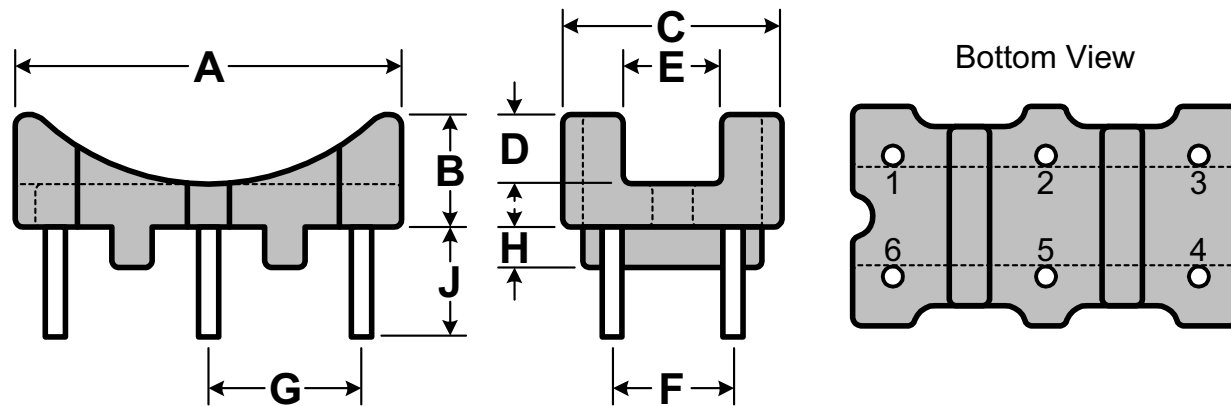

Material	6 Pins	A Nom.	B Nom.	C Nom.	D Nom.	E Ref.	F Typ.	G Typ.	H Ref.	J Ref.
Phenolic rated UL94V0	1.0 mm CP wire	19.0 mm 0.748"	5.5 mm 0.216"	10.8 mm 0.425"	3.5 mm 0.138"	4.8 mm 0.189"	6.0 mm 0.236"	7.5 mm 0.295"	2.0 mm 0.079"	5.5 mm 0.216"

TVB2908TA

Usable with toroids from 20.5 mm (0.810") through 31.8 mm (1.250")

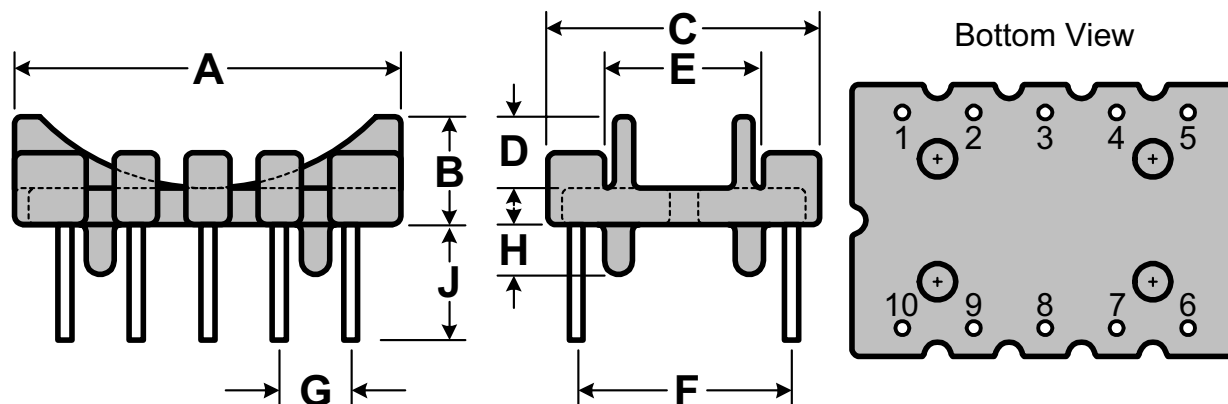

Material	10 Pins	A Nom.	B Nom.	C Nom.	D Nom.	E Ref.	F Typ.	G Typ.	H Ref.	J Ref.
Phenolic rated UL94V0	1.0 mm CP wire	27.0 mm 1.063"	7.5 mm 0.295"	19.0 mm 0.748"	5.0 mm 0.197"	11.0 mm 0.432"	15.0 mm 0.590"	5.0 mm 0.197"	3.5 mm 0.138"	8.13 mm 0.320"

Hardware

TVB3610FA

Usable with toroids from 28.6 mm (1.125") through 38.1 mm (1.500")

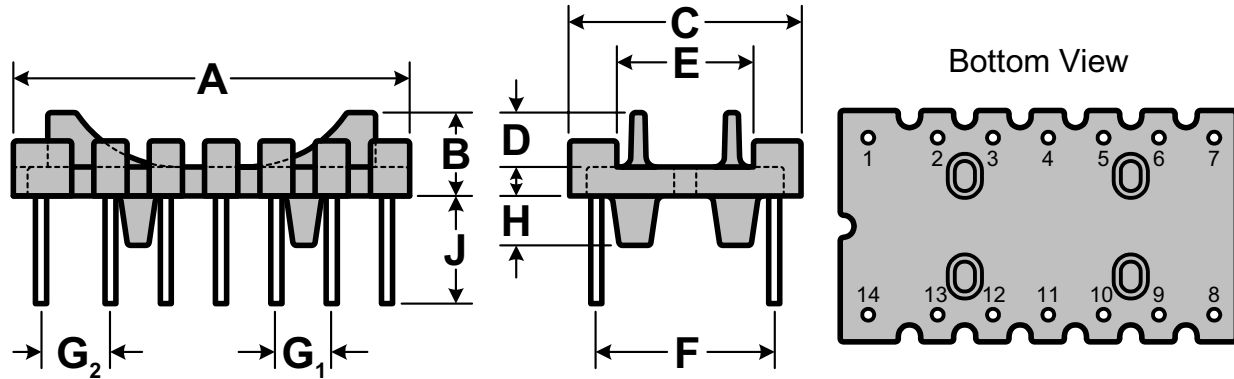

Material	14 Pins	A Nom.	B Nom.	C Nom.	D Nom.	E Ref.	F Typ.	G ₁ Typ.	G ₂ Typ.	H Ref.	J Ref.
Phenolic rated UL94V0	1.0 mm CP wire	35.8 mm 1.409"	7.6 mm 0.299"	20.8 mm 0.819"	5.0 mm 0.197"	12.3 mm 0.484"	16.0 mm 0.630"	5.0 mm 0.197"	6.3 mm 0.248"	4.5 mm 0.177"	9.75 mm 0.384"

TVH22064A

Usable with toroids from 12.7 mm (0.500") through 25.4 mm (1.000")

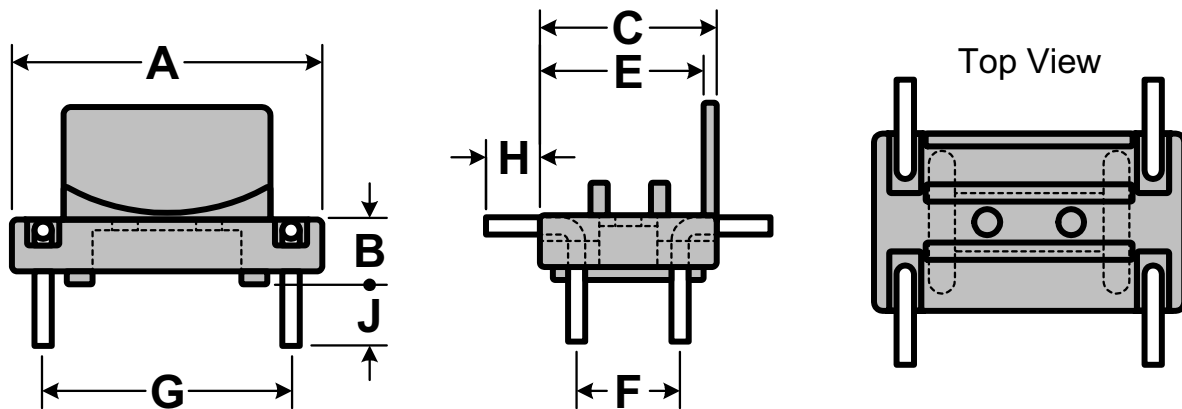

Material	4 Pins	A Nom.	B Nom.	C Nom.	E Ref.	F Typ.	G Typ.	H Typ.	J Typ.
Nylon rated UL94V0	0.040" CP wire	19.0 mm 0.750"	3.9 mm 0.155"	10.8 mm 0.425"	9.8 mm 0.385"	6.4 mm 0.250"	15.2 mm 0.600"	3.3 mm 0.130"	3.8 mm 0.150"

Hardware

TVH25074A

Usable with toroids from 20.5 mm (0.810") through 30.5 mm (1.200")

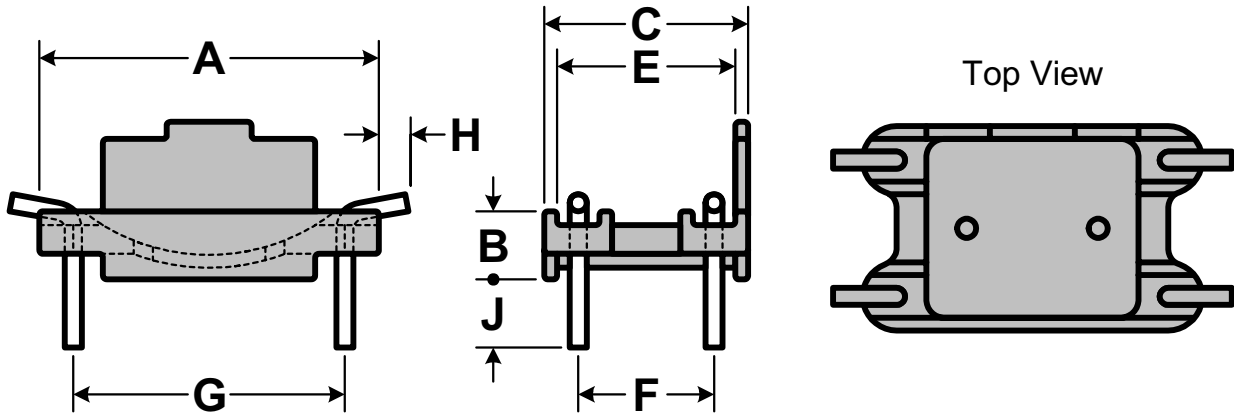

Material	4 Pins	A Nom.	B Nom.	C Nom.	E Ref.	F Typ.	G Typ.	H Typ.	J Typ.
Nylon rated UL94V0	CP wire 0.050"	25.4 mm 1.000"	5.1 mm 0.200"	15.2 mm 0.600"	13.0 mm 0.510"	10.2 mm 0.400"	20.33 mm 0.800"	2.3 mm 0.090"	5.1 mm 0.200"

TVH38134A

Usable with toroids from 25.4 mm (1.000") through 40.6 mm (1.600")

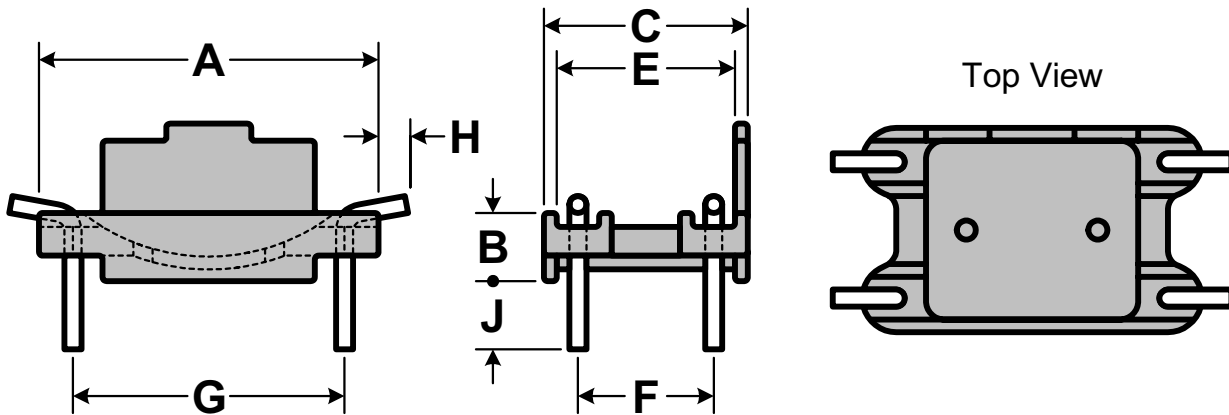

Material	4 Pins	A Nom.	B Nom.	C Nom.	E Ref.	F Typ.	G Typ.	H Typ.	J Typ.
Nylon rated UL94V0	CP wire 0.050"	27.9 mm 1.100"	5.1 mm 0.200"	20.3 mm 0.800"	18.0 mm 0.710"	15.2 mm 0.600"	22.9 mm 0.900"	2.3 mm 0.090"	5.1 mm 0.200"

Hardware

TVH41964A

Usable with toroids from 38.1 mm (1.500") through 63.5 mm (2.500")

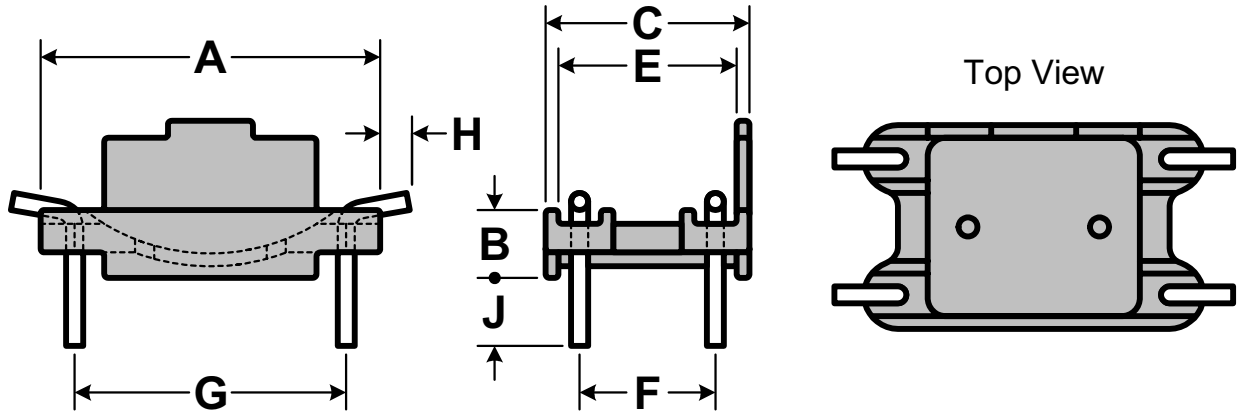

Material	4 Pins	A Nom.	B Nom.	C Nom.	E Ref.	F Typ.	G Typ.	H Typ.	J Typ.
Nylon rated UL94V0	CP wire 0.050"	35.6 mm 1.400"	5.1 mm 0.200"	22.9 mm 0.900"	20.6 mm 0.810"	17.8 mm 0.700"	30.5 mm 1.200"	2.3 mm 0.090"	5.1 mm 0.200"

TVH61134A

Usable with toroids from 44.4 mm (1.750") through 71.1 mm (2.800")

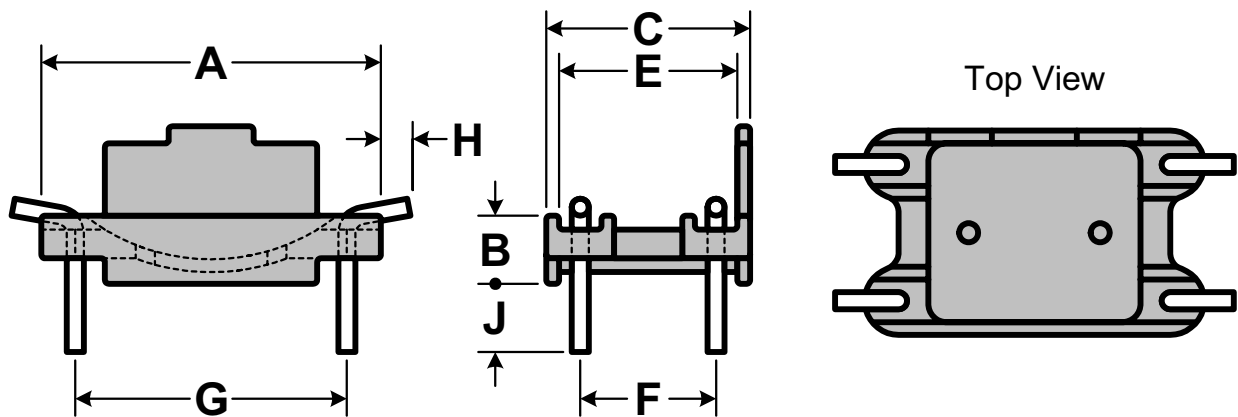

Material	4 Pins	A Nom.	B Nom.	C Nom.	E Ref.	F Typ.	G Typ.	H Typ.	J Typ.
Nylon rated UL94V0	CP wire 0.050"	43.2 mm 1.700"	5.1 mm 0.200"	27.9 mm 1.100"	25.7 mm 1.010"	22.9 mm 0.900"	38.1 mm 1.500"	2.3 mm 0.090"	5.1 mm 0.200"

Kool M μ [®] E Core Hardware

Magnetics has bobbins available for use with Kool M μ E cores. Refer to Magnetics Ferrite Cores catalog for a complete listing of available bobbins. The cores are standard industry sizes that will fit standard bobbins available from many sources. Core pieces can be assembled by bonding the mating surfaces and taping around the perimeter of the core set.

Core Number	Bobbin Number	Number of Pins	Winding Area		Length Per Turn	
			Winding Area (cm ²)	Winding Area (in ²)	Length per Turn (cm)	Length per Turn (ft)
00K1808E (EI-187)	PCB180881	8	0.316	0.049	4.05	0.133
00K2510E (E-2425)	PCB2510T1	10	0.406	0.063	5.42	0.178
00K3007E (DIN 30/7)	PCB3007T1	10	0.833	0.129	5.5	0.18
00K3515E (EI-375)	PCB3515L1	12	0.948	0.147	7.34	0.241
00K4020E (DIN 42/15)	PCB4020L1	12	1.94	0.300	9.14	0.300
00K4022E (DIN 42/20)	PCB4022L1	12	1.94	0.300	10.21	0.335
00K4317E (EI-21)	PCB4317L1	12	1.01	0.156	8.56	0.281
00K5528E (DIN 55/21)	PCB5528WA	20	3.02	0.468	10.73	0.352
00K5530E (DIN 55/25)	PCB5530FA	14	2.89	0.448	13.38	0.439
00K7228E (F11)	00B722801	-	4.08	0.632	14.9	0.49
00K8020E (Metric E80)	00B802001	-	8.06	1.25	16.5	0.542

Other Products From Magnetics

Ferrites

MAGNETICS' ferrite cores are manufactured for a wide variety of applications. MAGNETICS has developed and produces the leading MnZn ferrite materials for power transformers, power inductors, wideband transformers, common mode chokes, and many other applications. In addition to offering the leading materials, other advantages of ferrites from MAGNETICS include: the full range of standard planar E and I cores; rapid prototyping capability for new development; the widest range of toroid sizes in power and high permeability materials; standard gapping to precise inductance or mechanical dimension; wide range of coil former and assembly hardware available; and superior toroid coatings available in several options.

POWER MATERIALS

Three low loss materials are engineered for optimum frequency and temperature performance in power applications. MAGNETICS' R, P and F materials provide superior saturation, high temperature performance, low losses and product consistency.

SHAPES: E cores, Planar E cores, ETD, EC, U cores, I cores, PQ, Planar PQ, RM, Toroids (2 mm to 86 mm), Pot cores, RS (round-slab), DS (double slab), EP, Special Shapes

APPLICATIONS: Telecomm Power Supplies, Computer Power Supplies, Commercial Power Supplies, Consumer Power Supplies, Automotive, DC-DC Converters, Telecomm Data Interfaces, Impedance Matching Transformers, Handheld Devices, High power control (gate drive), Computer Servers, Distributed Power (DC-DC), EMI Filters, Aerospace, Medical.

HIGH PERMEABILITY MATERIALS

Three high permeability materials (5000 μ J material, 10000 μ W material and 15000 μ H material) are engineered for optimum frequency and impedance performance in signal, choke and filter applications. These MAGNETICS' materials provide superior loss factor, frequency response, temperature performance, and product consistency.

SHAPES: Toroids (2 mm to 86 mm), E cores, U cores, RM, Pot cores, RS (round-slab), DS (double slab), EP, Special Shapes

APPLICATIONS: Common Mode Chokes, EMI Filters, Other Filters, Current Sensors, Telecomm Data Interfaces, Impedance matching interfaces, Handheld devices, Spike Suppression, Gate Drive Transformers

SPECIAL MATERIALS

A number of special materials are engineered for specific performance results, including frequency response, temperature factor, Curie temperature, permeability across temperature for GFCI and telecomm performance, and loss factor. MAGNETICS' special materials provide outstanding performance, customization options and superior product consistency.

SHAPES: E cores, Planar E cores, ETD, EC, U cores, I cores, PQ, Planar PQ, RM, Toroids (2 mm to 86 mm), Pot cores, RS (round-slab), DS (double slab), EP, Special Shapes

APPLICATIONS: EMI Filters, Current sensors, Chokes, Tuned Filters, Data interfaces, Special temperature requirements, Other Special Requirements

Strip Wound Cores

Tape wound cores are made from high permeability alloys of nickel-iron, grain oriented silicon-iron. The alloys are known as Orthonol[®], Alloy 48, Square Permalloy 80, Supermalloy and Magnesil[®]. Cores are available in more than 50 standard sizes. For a wide range of frequency applications, materials are produced in thicknesses from 1/2 mil (0.013 mm) through 14 mils (0.356 mm). Cases are robust nylon boxes, rated for 200° C continuous operation and 2000 voltage minimum breakdown.

APPLICATIONS: Magnetic Amplifiers, Reactors, Regulators, Static Magnetic Devices and Current Transformers.

Miniature Tape Wound Bobbin Cores are manufactured from Permalloy 80 and Orthonol ultra-thin tape (0.000125" to 0.001" thick). They are available in widths from 0.031" to 0.250" (wider on special request). Wound on non-magnetic stainless steel bobbins, core diameters are available down to 0.050", with flux capacities as low as several maxwells.

MAGNETICS' sophisticated pulse test equipment reproduces most test programs and can measure accurately in the millivolt-microsecond region.

APPLICATIONS: Magnetometers, Flux Gates, Oscillators, Inverters and Magnetic amplifiers

Machined Prototypes and Custom Components

MAGNETICS' world-class materials offer unique and powerful advantages to almost any application. An even greater competitive edge can be gained through innovations in new core shapes and custom geometries, and MAGNETICS is poised to help. Our Rapid Prototyping Service can quickly make a wide variety of core shapes in ferrite, MPP, High Flux, or Kool M μ [®]. The time between receipt of your drawing and delivery of the parts to you is usually less than 10 days. This quick turnaround time results in a shorter design period, which gets your product to market faster. Plus, our application engineers may be able to provide design assistance that could lead to a lower piece price. To learn more about how our Rapid Prototyping Service can help you shorten your design cycle, contact a MAGNETICS Application Engineer.

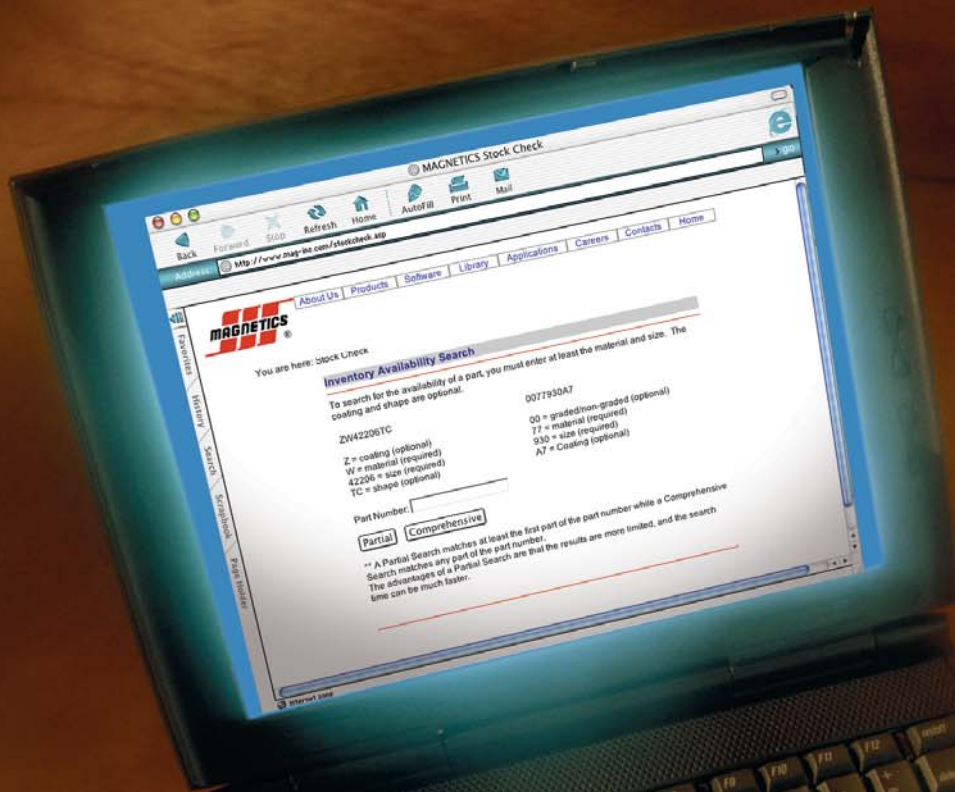

www.mag-inc.com

Check Stock Online

Now you can easily find a Magnetix core anywhere in the world using the StockCheck feature on the Magnetix website. StockCheck searches the databases of Magnetix' authorized distributors to quickly locate the part number you need. With Partial and Comprehensive search capabilities, it is easy to find the part you are looking for even if you do not have the full part number. The results are conveniently displayed by region to allow you to find the distributor closest to you. And, you can even e-mail a request for quote directly to any distributor. Updated daily, StockCheck provides instant and accurate access to Magnetix' distributor inventory 24 hours a day.

To use StockCheck:

- 1. Go to www.mag-inc.com/stockcheck.asp.
- 2. Enter the Magnetix part number you need.
- 3. Select Partial or Comprehensive search.

CD Now Available

MAGNETIX has developed an interactive CD that contains all of the company's publicly available design manuals, technical literature, and design software. The CD is a small 3-inch format for easy portability and is PC and Mac compatible. It allows the user to view, print, and run the software design aids directly from the CD. This CD is free and available from MAGNETIX or any of the company's distributors or agents. To request a free CD, visit the MAGNETIX website at www.mag-inc.com.



P.O. Box 11422
Pittsburgh, PA 15238-0422
PHONE: 1.800.245.3984
PHONE: 412.696.1333
FAX: 412.696.0333

www.mag-inc.com

magnetics@spang.com