

Monitor and Timing Management for 4-Loop NiMH Battery Charger

Features

- Charges 1 to 4 NiMH packs
- Detects and avoids charging alkaline cells
- Monitors voltage, temperature and time for safety and secondary termination
- Drivers PNP type pass element
- Pre-charge qualification for detecting shorted, damaged, or deeply depleted cells
- Automatic recharge keeps batteries charged
- Optional temperature qualified charging

Applications

- NiMH battery charger for AAA/AA cells

Description

The GR5302 is ideal for standalone charging of 4-loop NiMH packs (AA or AAA NiMH loose cells), NiCd cells can also be charged. Temperature, voltage and charge time are monitored to provide proper fast/slow charging control algorithms for Nickel Metal Hydride (NiMH) batteries. The GR5302 detects the battery chemistry and proceeds with the optimal charging and termination algorithms. This process eliminates undesirable undercharged or overcharged conditions and allows accurate and safe termination of fast/slow charge. Battery tests are included to detect defective or inappropriate cells such as alkaline primary batteries. The GR5302 series support four loops charging topology, with four independent monitoring and controls.

Ordering and Marking Information

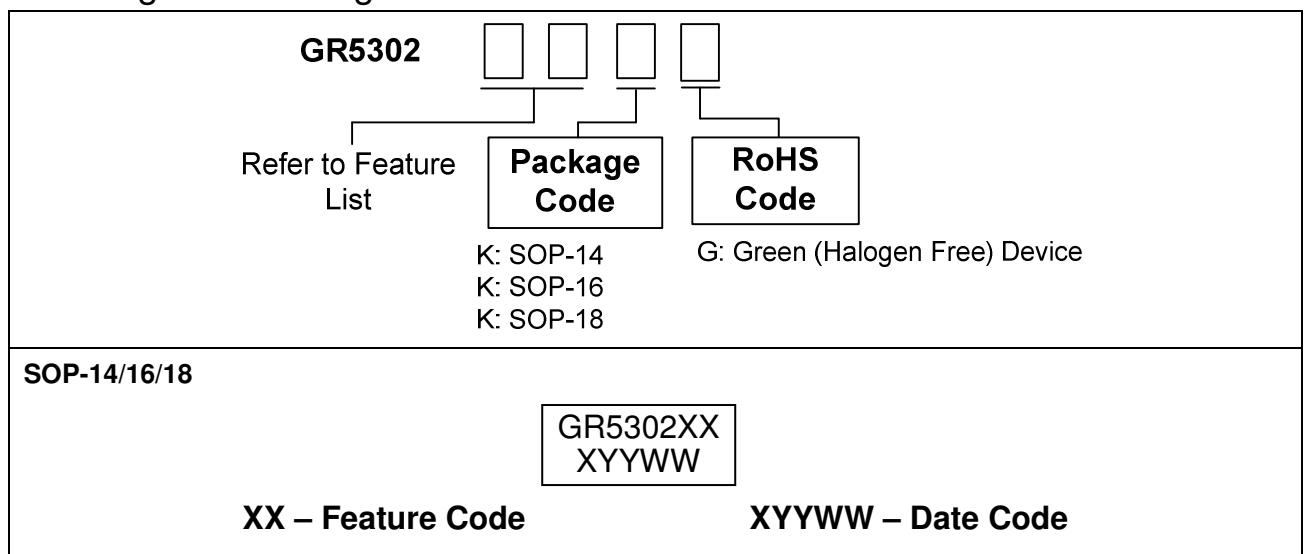

Greenergy OPTO Inc. reserves the right to make changes to improve reliability or manufacture ability without notice, and advise customers to obtain the latest version of relevant information to verify before placing orders.

Feature List

	Fixed Timing	Adjusted Timing	Single LED
Single Cell	GR5302AA (SOP-16)	GR5302AT (SOP-18)	GR5302AS (SOP-14)
Dual Cell	GR5302DA (SOP-16)	GR5302DT (SOP-18)	GR5302DS (SOP-14)

Pin Configuration

GR5302 AS/DS SOP-14(TOP VIEW)

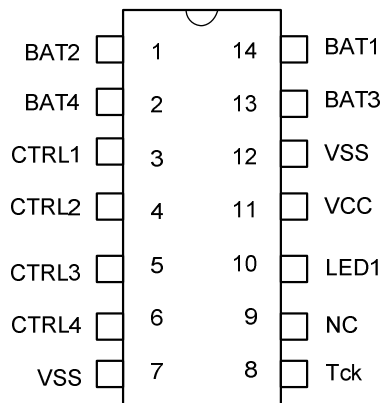

Pin Description

Pin No.	Symbol	Description
1	BAT2	Slot 2, battery voltage input
2	BAT4	Slot 4, battery voltage input
3	CTRL1	Slot 1, charge switch control
4	CTRL2	Slot 2, charge switch control
5	CTRL3	Slot 3, charge switch control
6	CTRL4	Slot 4, charge switch control
7, 12	VSS	Negative power supply
8	T _{CK}	Tck for test mode and time selection
9	NC	Not connect
10	LED1	Slot 1 charge/ Full status LED indicator
11	VCC	Positive power supply
13	BAT3	Slot 3, battery voltage input
14	BAT1	Slot 1, battery voltage input

Pin Configuration

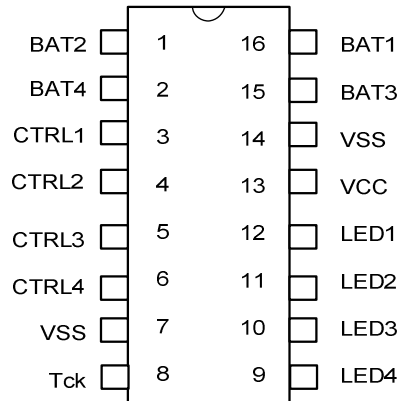
GR5302 AA/DA SOP-16 (TOP VIEW)

Pin Description

Pin No.	Symbol	Description
1	BAT2	Slot 2, battery voltage input
2	BAT4	Slot 4, battery voltage input
3	CTRL1	Slot 1, charge switch control
4	CTRL2	Slot 2, charge switch control
5	CTRL3	Slot 3, charge switch control
6	CTRL4	Slot 4, charge switch control
7, 14	VSS	Negative power supply
8	T _{CK}	Tck for test mode and time selection
9	LED4	Slot 4 charge/ Full status LED indicator
10	LED3	Slot 3 charge/ Full status LED indicator
11	LED2	Slot 2 charge/ Full status LED indicator
12	LED1	Slot 1 charge/ Full status LED indicator
13	VCC	Positive power supply
15	BAT3	Slot 3, battery voltage input
16	BAT1	Slot 1, battery voltage input

Pin Configuration

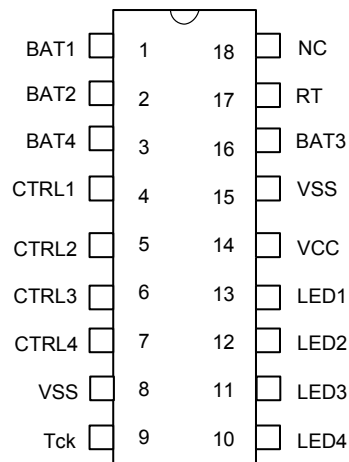
GR5302 AT/DT SOP-18 (TOP VIEW)

Pin Description

Pin No.	Symbol	Description
1	BAT1	Slot 1, battery voltage input
2	BAT2	Slot 2, battery voltage input
3	BAT4	Slot 4, battery voltage input
4	CTRL1	Slot 1, charge switch control
5	CTRL2	Slot 2, charge switch control
6	CTRL3	Slot 3, charge switch control
7	CTRL4	Slot 4, charge switch control
8, 15	VSS	Negative power supply
9	Tck	Tck for test mode and time selection
10	LED4	Slot 4 charge/ Full status LED indicator
11	LED3	Slot 3 charge/ Full status LED indicator
12	LED2	Slot 2 charge/ Full status LED indicator
13	LED1	Slot 1 charge/ Full status LED indicator
14	VCC	Positive power supply
16	BAT3	Slot 3, battery voltage input
17	RT	Timing Resistor
18	NC	Not connect

Absolute Maximum Ratings

Input voltage between VCC and VSS	-----	VSS -0.3 ~ VSS +5.5V
Battery voltage input	-----	VSS -0.3 ~ VSS +5V
LED sink current	-----	4mA
LED driver current	-----	4mA
Operating temperature range	-----	0 ~ 85 °C
Storage temperature range	-----	-40 ~ 125 °C

Block Diagram

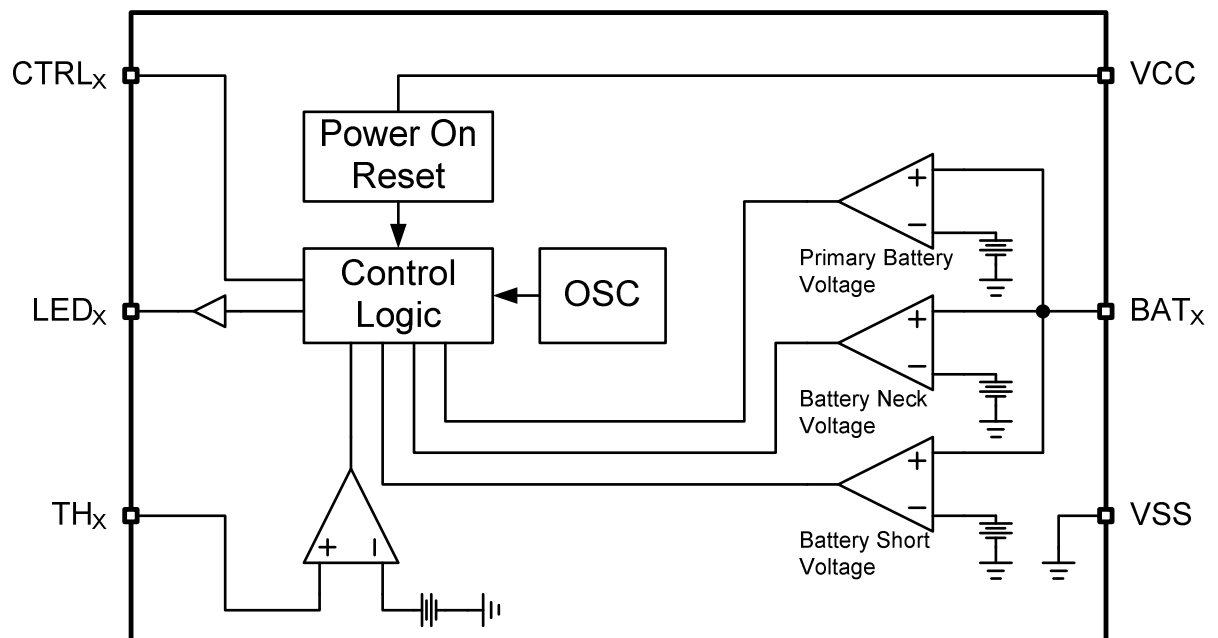

Electrical Characteristics (T_A = 25°C)

Parameter	Conditions	Symbol	Min	Typ	Max	Unit
-----------	------------	--------	-----	-----	-----	------

POWER SUPPLY

Operating voltage		V _{CC}	4.5	5.0	5.5	V
Supply current	V _{CC} = 5V	I _{CC}	0.4	0.5	0.6	mA
Battery voltage input	GR5302AA	V _{BAT}	0.5		2	V
	GR5302AT	V _{BAT}	0.5		2	V
	GR5302AS	V _{BAT}	0.5		2	V
	GR5302DA	V _{BAT}	1		4	V
	GR5302DT	V _{BAT}	1		4	V
	GR5302DS	V _{BAT}	1		4	V
LED sink current	V _{CC} = 5V	I _{LED-SINK}	2.5	3	3.5	mA
LED driver current	V _{CC} = 5V	I _{LED-Driver}	2.5	3	3.5	mA
Thermistor input		V _{TH}	1.07	1.12	1.17	V

PROTECTION VOLTAGE

Battery short voltage		Vshort	0.45	0.5	0.55	V
Primary battery voltage	GR5302AA	Vprimary	1.575	1.6	1.625	V
	GR5302AT	Vprimary	1.575	1.6	1.625	V
	GR5302AS	Vprimary	1.575	1.6	1.625	V
	GR5302DA	Vprimary	3.15	3.2	3.25	V
	GR5302DT	Vprimary	3.15	3.2	3.25	V
	GR5302DS	Vprimary	3.15	3.2	3.25	V
Battery neck voltage	GR5302AA	Vneck	1.395	1.42	1.445	V
	GR5302AT	Vneck	1.395	1.42	1.445	V
	GR5302AS	Vneck	1.395	1.42	1.445	V
	GR5302DA	Vneck	2.79	2.84	2.89	V
	GR5302DT	Vneck	2.79	2.84	2.89	V
	GR5302DS	Vneck	2.79	2.84	2.89	V

SAFE TIMER

GR5302AA, GR5302AS, GR5302DA, GR5302DS						
Safe Charge Timer	TCK = HI	Timer	11.5	12	12.5	hour
Safe Charge Timer	TCK = LO	Timer	5.5	6	6.5	hour
GR5302AT, GR5302DT (Note 1)						
Safe Charge Timer	TCK = HI	Timer	2 (RT=200KΩ)	12 (RT=450KΩ)	18 (RT=700KΩ)	hour
Safe Charge Timer	TCK = LO	Timer	1 (RT=200KΩ)	6 (RT=450KΩ)	9 (RT=700KΩ)	hour

Note 1: The timer of GR5302AT, GR5302DT could be any value between min and max by changing RT value.

Typical Application Circuit

GR5302AA/DA

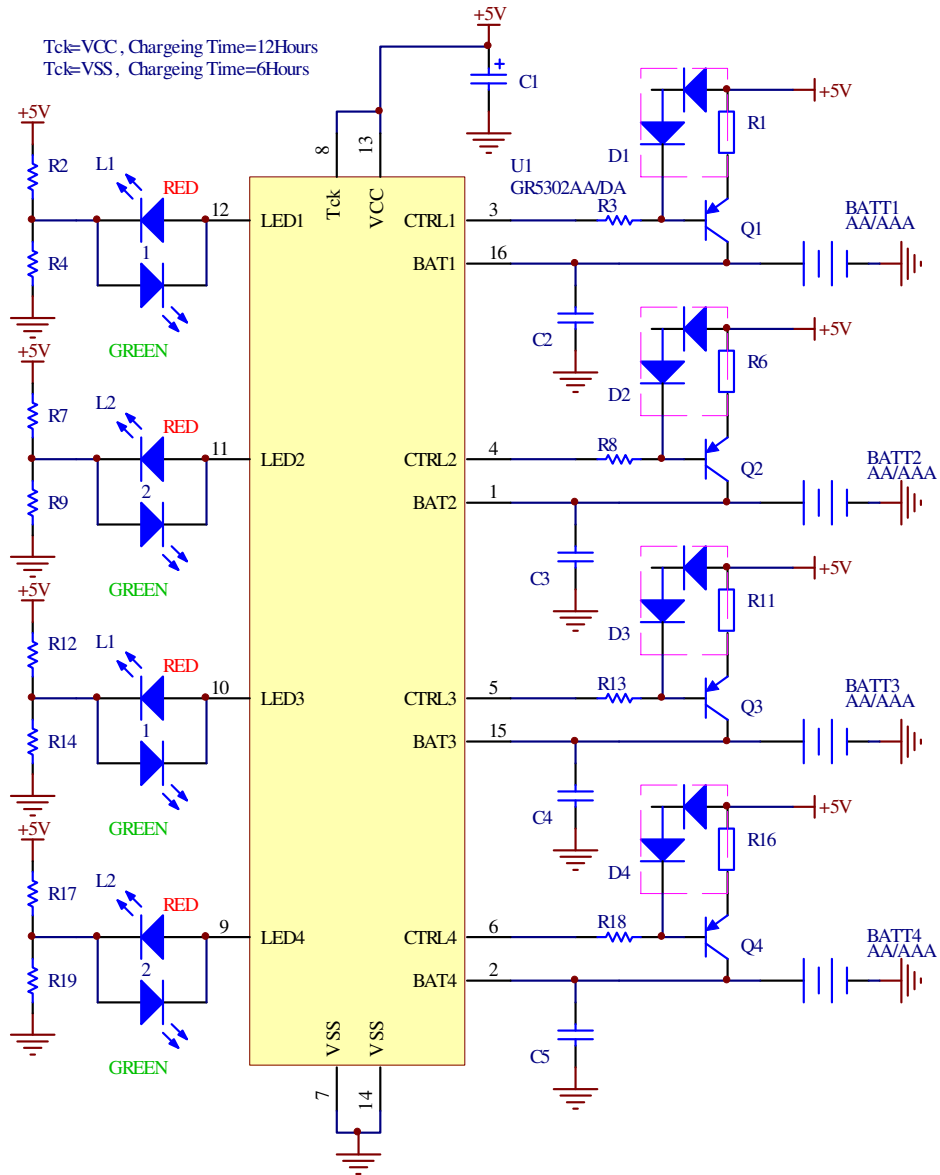

Typical Application Circuit

GR5302AT/DT

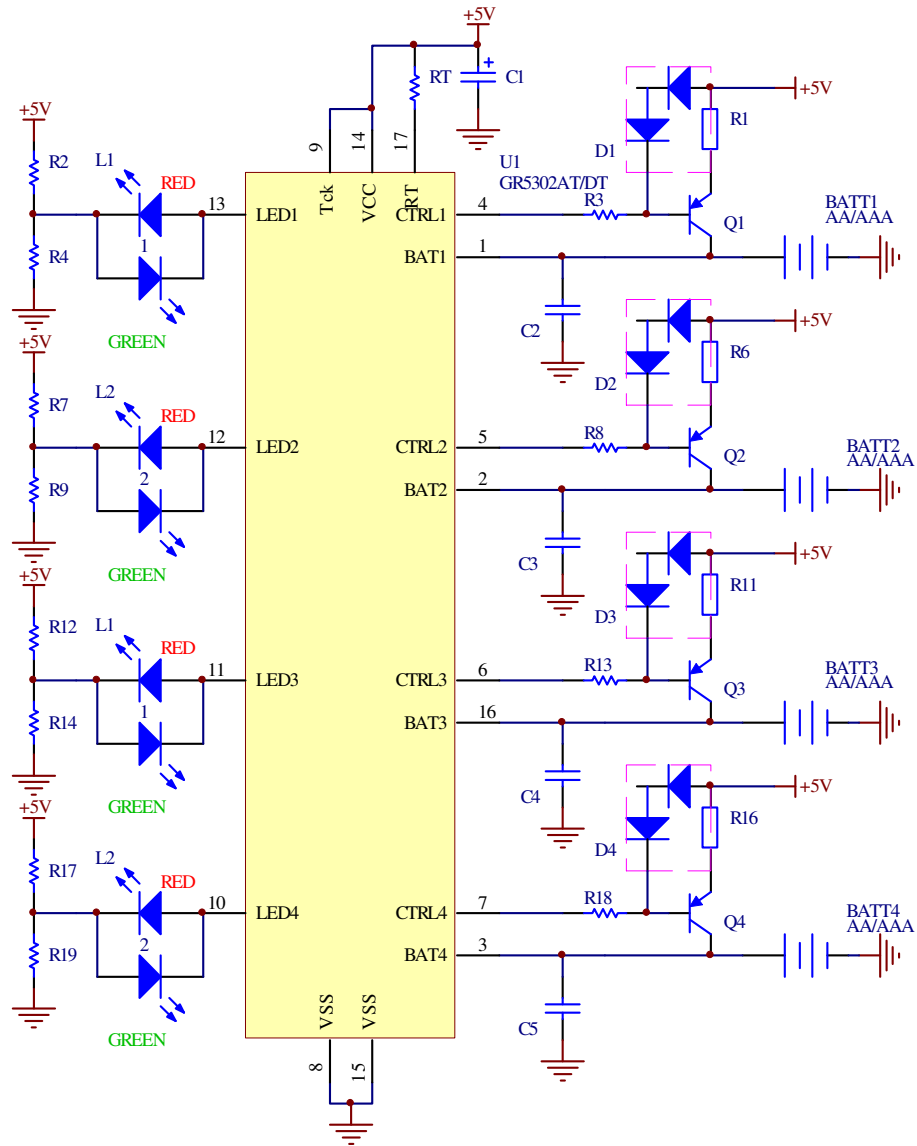

Typical Application Circuit

GR5302AS/DS

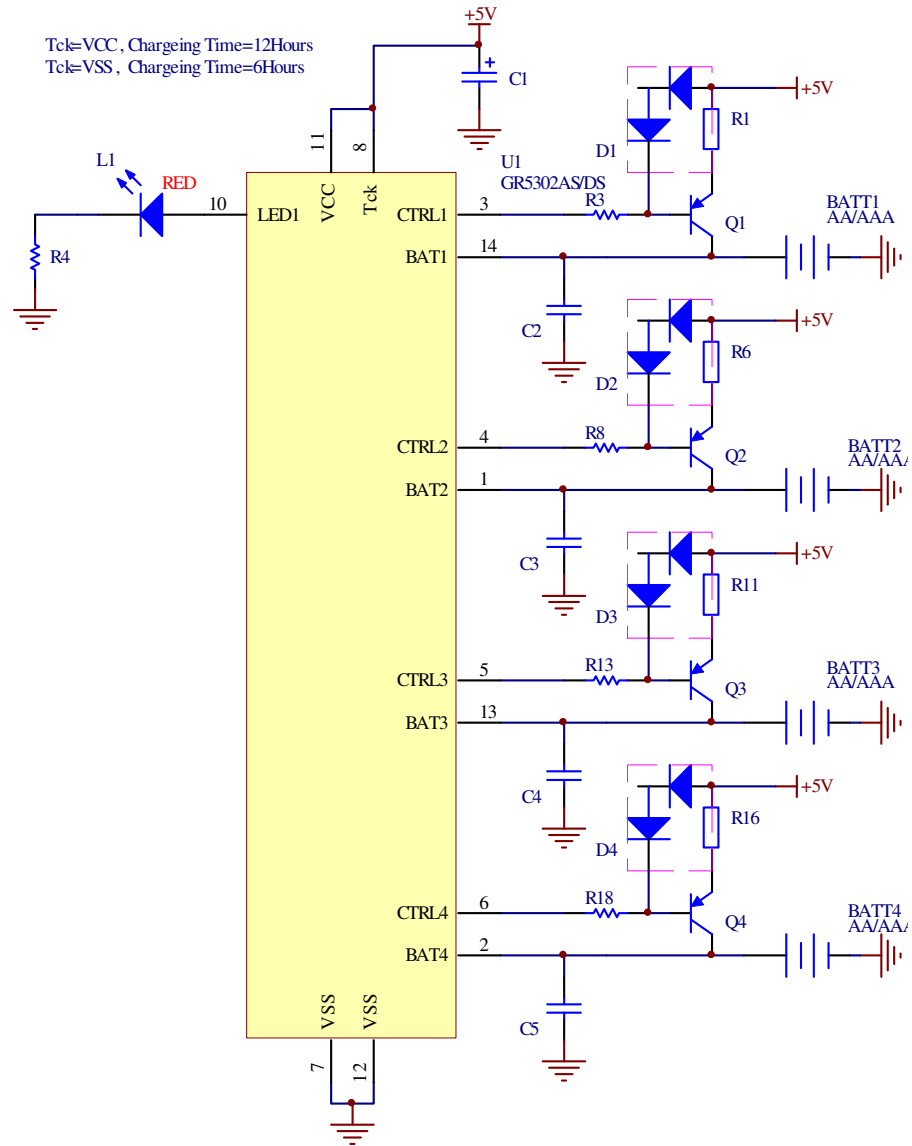

Package Information

SOP-14

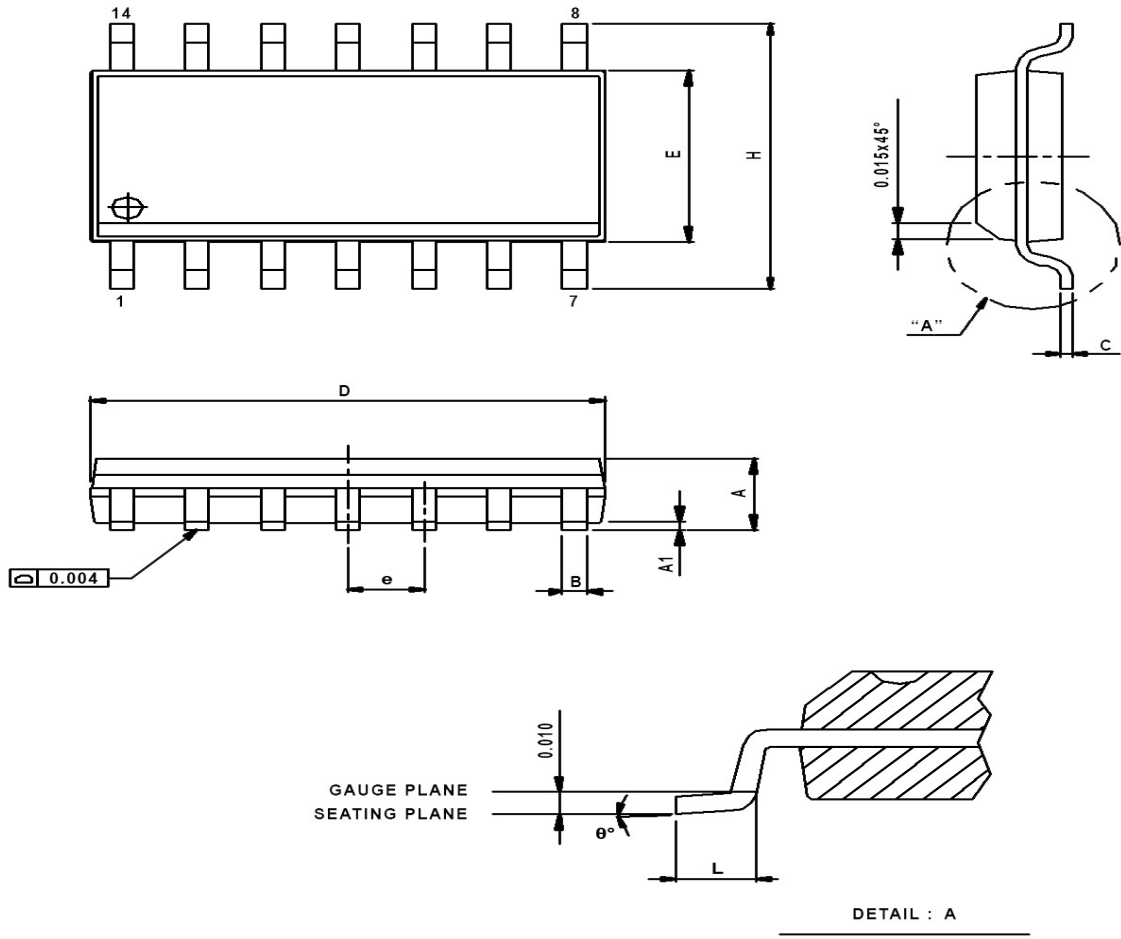

Symbols	MIN.	NOM.	MAX.
A	0.058	0.064	0.068
A1	0.004	-	0.010
B	0.013	0.016	0.020
C	0.0075	0.008	0.0098
D	0.336	0.341	0.344
E	0.150	0.154	0.157
e	-	0.050	-
H	0.228	0.236	0.244
L	0.015	0.025	0.050
θ°	0	-	8

UNIT: INCH

Package Information

SOP-16

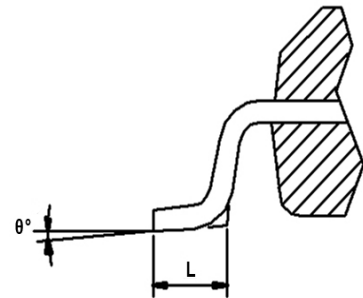
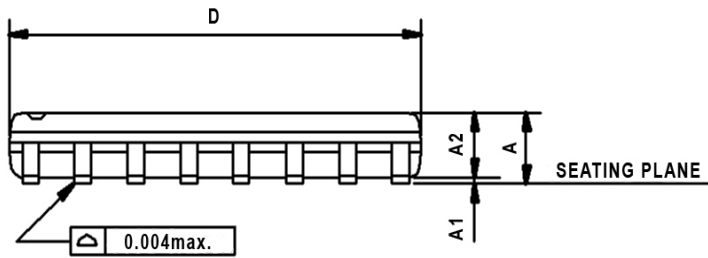
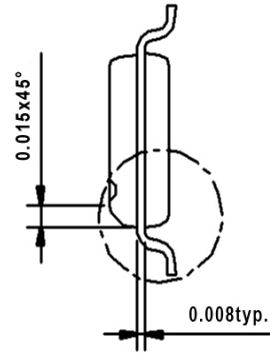
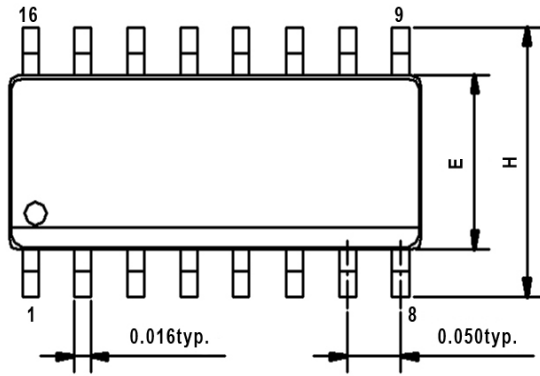

Symbols	Min.	Max.
A	0.053	0.069
A1	0.004	0.010
A2	0.049	0.065
D	0.386	0.394
E	0.150	0.157
H	0.228	0.244
L	0.016	0.050
θ°	0	8

UNIT: INCH

Package Information

SOP-18

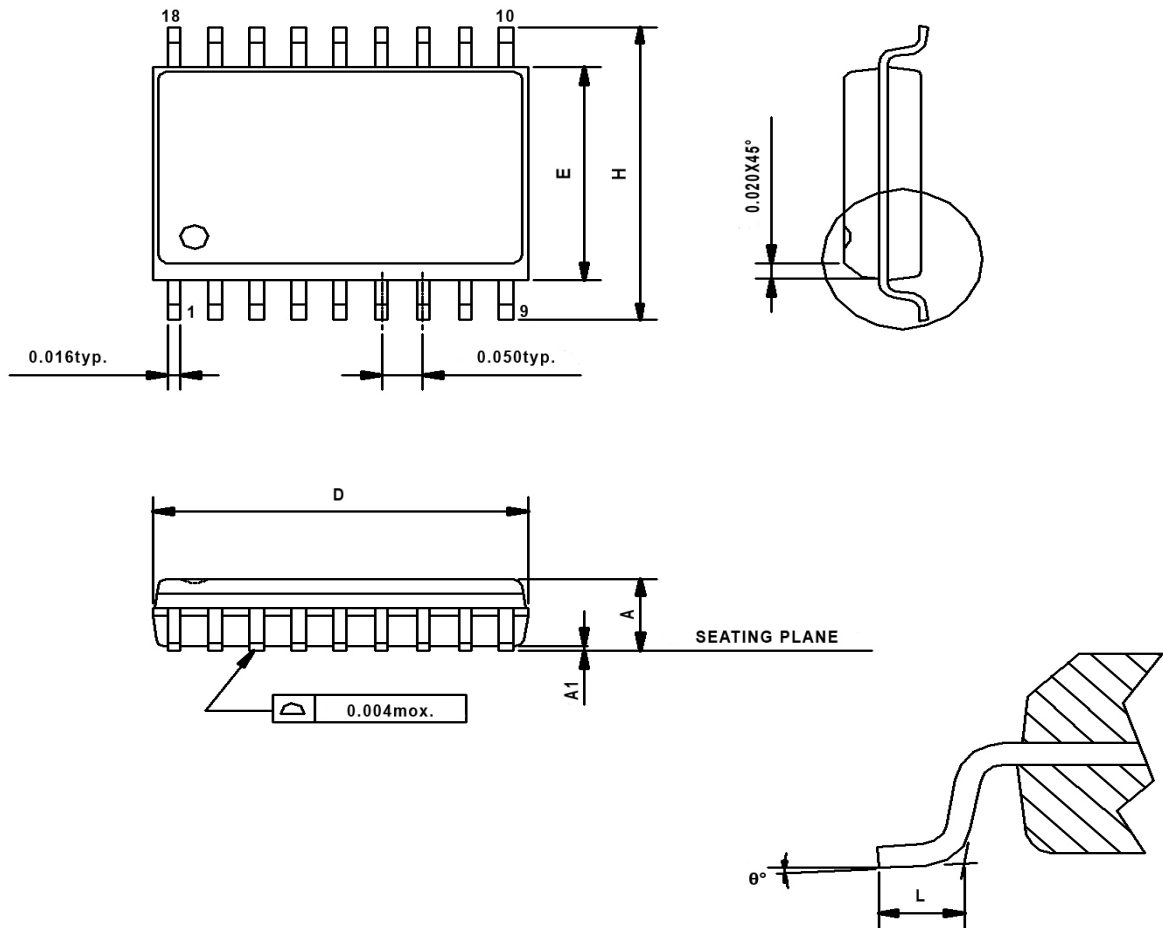

Symbols	Min.	Max.
A	0.093	0.104
A1	0.004	0.012
D	0.447	0.463
E	0.291	0.299
H	0.394	0.419
L	0.016	0.050
θ°	0	8

UNIT: INCH

Carrier Tape & Reel Dimensions

SOP-14/16

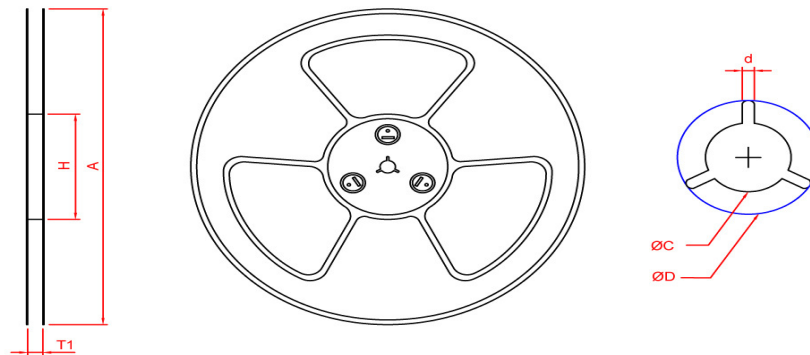
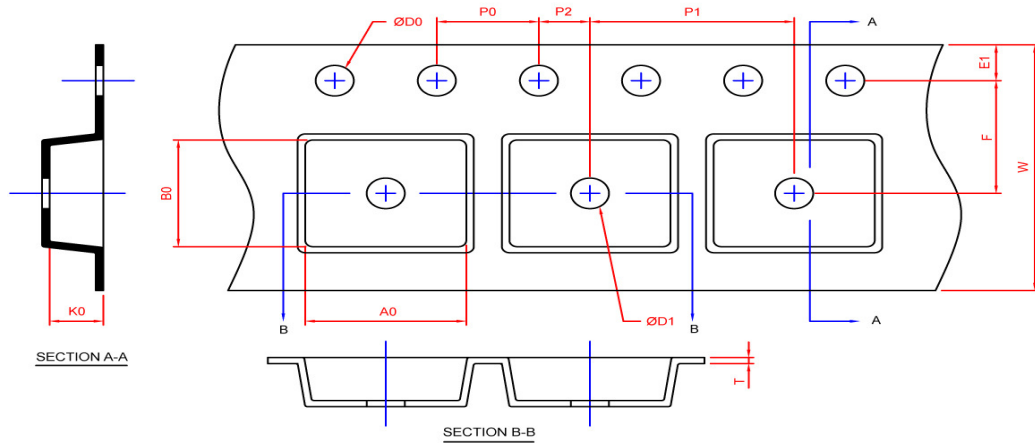

Application	A	H	T1	C	d	D	W	E1	F
SOP-14	330.0±2.0	100 REF	1.4	13.0 + 0.5 - 0.2	2.0±0.5	16.5 REF	16.0±0.2	1.75±0.1	7.5±0.1
	P0	P1	P2	D0	D1	T	A0	B0	K0
	4.0±0.1	8.0±0.1	2.0±0.1	1.5+0.1 -0.0	1.5 MIN.	0.3±0.05	6.5±0.1	9.5±0.1	2.1±0.1
SOP-16	A	H	T1	C	d	D	W	E1	F
	330.0±2.0	100 REF	1.4	13.0 + 0.5 - 0.2	2.0±0.5	16.5 REF	16.0±0.2	1.75±0.1	7.5±0.1
	P0	P1	P2	D0	D1	T	A0	B0	K0
	4.0±0.1	8.0±0.1	2.0±0.1	1.5+0.1 -0.0	1.5 MIN.	0.3±0.05	6.5±0.1	10.3±0.1	2.1±0.1

(mm)

Carrier Tape & Reel Dimensions

SOP-18

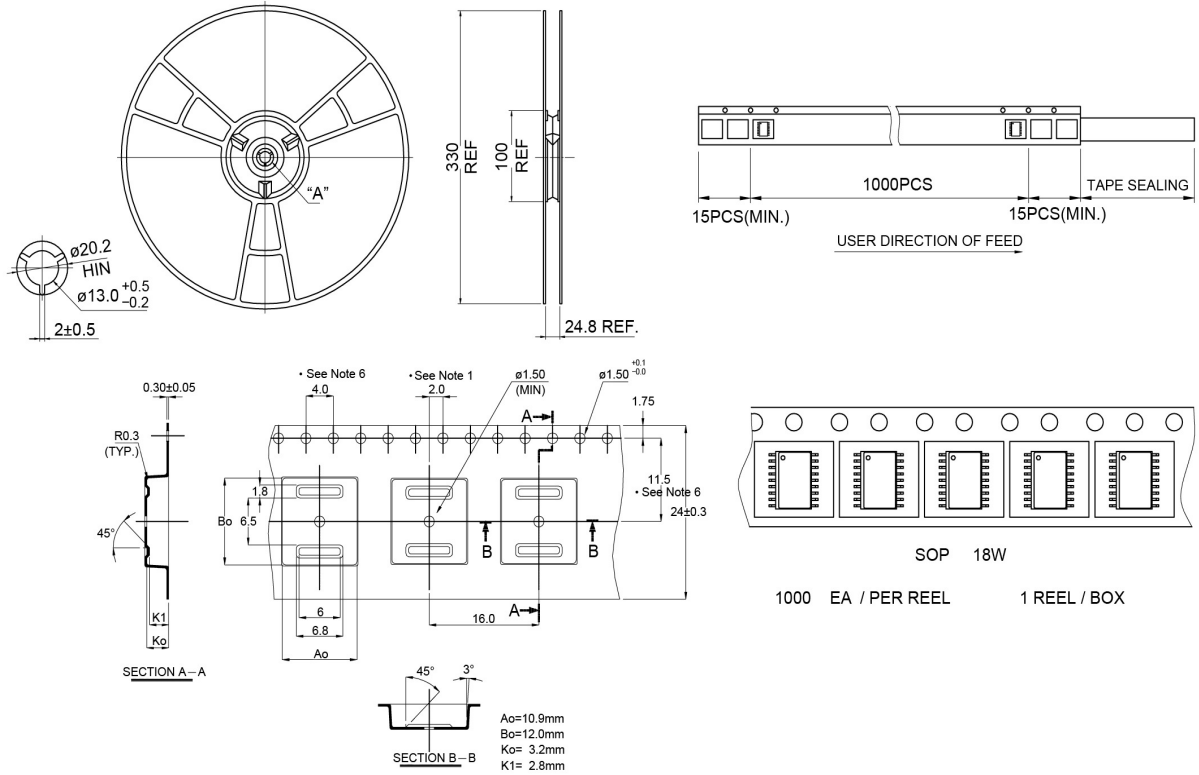

Application	Devices Per Reel
SOP-14	2500
SOP-16	2500
SOP-18	1000

Greenergy OPTO, Inc. reserves the right to make corrections, modifications, enhancements, improvements, and other changes to its products and services at any time and to discontinue any product or service without notice. Customers should obtain the latest relevant information before placing orders and should verify that such information is current and complete.