

Demo Board Test Report for LD7591

--- 14.7W (42V, 0.35A) Adapter

Tested by	Reviewed by	Approved by
Renyi Chen/Jolin Lin		

Total pages	Revision	Date
19	01	2010/05/13

Contents

I. SCHEMATIC	3
II. BOM.....	4
III. EXECUTIVE SUMMARY.....	5
IV. GERBER FILE.....	21

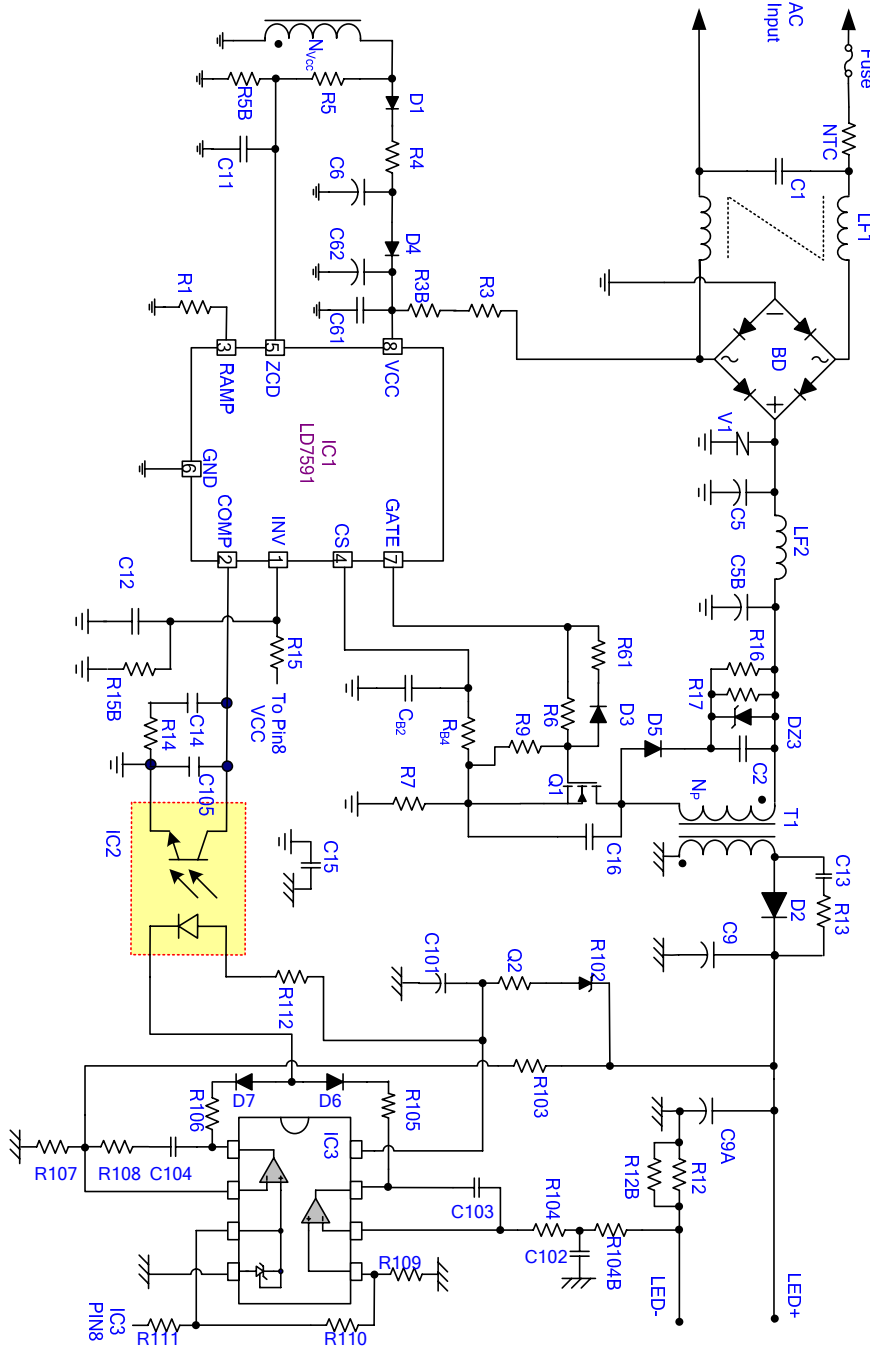
I. SCHEMATIC

II. BOM

P/N	Component Value	
Fuse	2A/250V	
NTC	0Ω, 1206	
V1	Varistor	471
R1	22kΩ, 0805	
R2	NC	
R3	100kΩ, 1206	
R3B	100kΩ, 1206	
R4	24Ω, 1206	
R5	100kΩ, 0805	
R5B	10kΩ, 0805	
R6	51Ω, 0805	
R61	0Ω, 0805	
R7	0.75Ω	1/2W
R9	100kΩ, 0805	
R12	0.68Ω,	2W
R12B	NC,1206	
R13	100Ω, 1206	
R14	1kΩ, 0805	
R15	7.5MEGΩ, 0805	
R15B	620kΩ, 0805	
R16	NC	
R17	100kΩ, 1206	
RB4	200Ω, 0805	
R101	NC, 0805	
R102	8.2V Zener	
R103	470k	
R104	0Ω, 0805	
R104B	10kΩ, 0805	
R105	20kΩ, 0805	
R106	0Ω, 0805	
R107	27kΩ, 0805	
R108	39kΩ, 0805	
R109	10kΩ, 0805	
R110	100kΩ, 0805	
R111	33kΩ	
R112	3kΩ, 0805	
R113	NC, 0805	
R114	0Ω, 0805	
IC1	LD7591	SOP-8
IC2	PC817	
IC3	TSM103, SOP8	

P/N	Component Value	Note
C1	0.1μF / 275VAC	X-cap
C2	4.7nF/1kV,1206	
C5	0.047μF / 400V	MPF 塑膠電容
C5B	0.1μF / 400V	MPF 塑膠電容
C6	22uF/ 50V	Electrolytic Capacitor
C61	3.2μF /25V/0805	
C62	33uF/ 50V	
C9	330μF, 50V	Electrolytic Capacitor
C9A	330μF, 50V	Electrolytic Capacitor
C11	NC, 0805	
C12	10pF, 0805	
C13	470pF/500V, 1206	
C14	1μF/ 16V, 0805	
C15	2200pF,	Y 電容
C16	NC /1kV,1206	
C101	2.2uF/ 50V	
C102	4.7μF/10V/0805	
C103	0.1μF/ 25V, 0805	
C104	0.1μF/ 25V, 0805	
C105	0.1μF/25V/0805	
CB2	220pF/16V, 0805	
D1	BAV103	
D2	ER502	200V/ 5A,
D3	LL4148	SOD-80
D4	LL4148	SOD-80
D5	1N4007	1000V/1A
D6	LL4148	SOD-80
D7	LL4148	SOD-80
DZ1	NC	
DZ2	NC	
DZ4	NC	
DZ3	NC	DO-15
BD	DI106	600V/1A
T1	EF20, 1150uH	106/32/13
LF1	UU9.8	
LF2	1150uH	
Q1	FQPF5N60C	600V, 4.5A, TO-220
Q2	330R, 0805	

III. EXECUTIVE SUMMARY	6
1. INPUT VOLTAGE & FREQUENCY	7
2. OUTPUT LOADS.....	7
3. GREEN MODE POWER CONSUMPTION	7
4. LOAD REGULATION	8
5. TURN ON DELAY TIME	9
6. EFFICIENCY , PF TEST.....	10
7. STRESS VOLTAGE TEST	11
8. KEY PARTS FOR THERMAL TEST	13
9. EMI CONDUCTION	14
10. SURGE FOR SYSTEM	18

III. EXECUTIVE SUMMARY

Office	Taipei
Model Name	LD7591-DemoBoard#01
Version	01
IC	LD7591(D/C:)

TEST	Result	Comments
3. Green Mode Power Consumption	PASS	
4. Turn On Delay Time	PASS	
5. Efficiency , PF Test	PASS	
6. Stress Voltage Test	PASS	
7. Thermal Test	PASS	

1. Input Voltage & Frequency

The unit shall be capable of operating as a universal AC input power supply accepting AC inputs. The power supply shall operate between the following voltages (from 90V to 264V). The supply will be designed to operate for a Table 1.

	Minimum	Normal	Maximum
Input Voltage	90Vac	110Vac	264Vac
Frequency	47HZ	60HZ	63HZ

Table 1.

2. Output Loads

The line and load regulation for each of the outputs are shown in Table. 2.

Parameter	Output Voltage			Output Current	
	Minimum	Typical	Maximum	Minimum	Maximum
+42V		42V		0A	0.35A
Line Regulation	-5%	/	+5%	/	0.35A
Load Regulation	-5%	/	+5%	0A	0.35A

Table 2.

3. Green Mode Power Consumption

The input power of power supply shall remain **less than 500mW** under output at no load condition.

Test Condition:

Input: 115Vac/230Vac (60Hz)

Output: No Load

Ambient Temperature: 25°C

Test Result: PASS

V_{in} (Vac)	Pout(W)	Pin(mW)
90	No Load	262.8
115	No Load	283.4
230	No Load	404.2
264	No Load	450.6

Table 3.

4. Turn On Delay Time

Turn on delay time will be less than 3 seconds at full load. Turn on delay time is measured as the delay between input voltage being applied at 0° phase angle and when the outputs arrive within 10% of their operating value. Turn on delay time is measured using an input voltage of 90VAC(rms) and input frequency of 60Hz.

Test Conditions:

Input: 90Vac(60Hz)

Output: 42V/0.35A (Electronic Load Setup:CV mode)

Ambient Temperature : 25°C

Test Result: PASS

Input	T _{turn on delay}
90Vac	2.41s

Table 4.

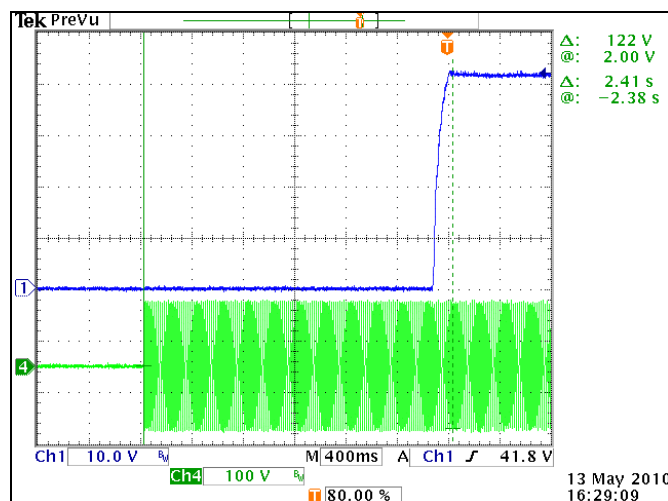

Turn on Time Test
 Vin: 90Vac/60Hz
 O/P: 42V/0.35A
 CH1: V_{O_+42V}
 CH4: AC Input Voltage
 Reading: **2.41s**

Fig.1

5. Efficiency and PF Test

The efficiency of power supply shall be measured throughout its specified operating input range and at output maximum load conditions. It should remain **80% minimum**. PF > 0.9 .

Test Condition:

Input: 90Vac/115Vac/230Vac/264Vac(60Hz)

Output: 42V (CV mode) & 121.21Ω/100Ω(CR mode)

Ambient Temperature: 25°C

	90V	115V	230V	264V
PF(CV mode) Electronic Load:42V	0.9936	0.9945	0.9615	0.9422
PF(CR mode) Electronic Load:121.21Ω	0.9931	0.9949	0.9660	0.9498
PF(CR mode) Electronic Load:100Ω	0.9934	0.9942	0.9531	0.9296
Efficiency (CV mode) Electronic Load:42V	84.74%	86.08%	86.03%	85.30%

Table 5 Efficiency, PF TEST.

7. Power Component Stress Voltage
Test Condition:

- Set the output loads at full load and ambient 25 °C.
- The PSU test on everyone voltage and frequency.

Check:

- Under Steady state the derating shall be below **100%**.
- Under Transient state the derating shall be below **100%**.
- Input line bulk capacitors limits are **100%** (continuous).

Result:
Input Voltage: 90Vac/264Vac (47/63Hz)

Output Power: 42V/0.35A (Electronic Load Setup:CV mode)

No.	Location	Max. Rating(V)	Steady State(90V / 47HZ)	
			Measurement	Derating(%)
			V	V
1	Q1	600	266	44.33%
2	D2	200	83.6	41.80%
3	D1	100	33.8	33.80%
4	D5	600	280	46.67%

Table 6-1.

No.	Location	Max. Rating(V)	Steady State(264V / 63HZ)	
			Measurement	Derating(%)
				V
1	Q1	600	560	93.33%
2	D2	200	153	76.50%
3	D1	100	62.4	62.40%
4	D5	600	284	47.33%

Table 6-2.

No.	Location	Max. Rating(V)	Transient State(90V / 47HZ)	
			Measurement	Derating(%)
			V	V
1	Q1	600	270	45.00%
2	D2	200	85.6	42.80%
3	D1	100	35.6	35.60%
4	D5	600	508	84.67%

Table 6-3.

No.	Location	Max. Rating(V)	Transient State(264V / 63HZ)	
			Measurement	Derating(%)
			V	V
1	Q1	600	580	96.67%
2	D2	200	187	93.50%
3	D1	100	72	72.00%
4	D5	600	530	88.33%

Table 6-4.

8. Thermal Test
Test Condition:

- Set the output loads at full load and ambient 25°C.
- The PSU test on everyone voltage and frequency.
- Born-In 2 hours

Check:

- All of component and magnetic device (transformer, Filter choke) shall NOT exceed 100°C.

Result:

No.	Location	Max. Rating(°C.)	90V/47Hz(°C.)	264/63Hz(°C.)	Derating(%)	
					90V/47Hz	264/63Hz
1	BD	150	54.2	41.6	36.13%	27.73%
2	DZ3	150	69.7	72.5	46.47%	48.33%
3	D5	150	72.5	74.2	48.33%	49.47%
4	T1	130	68.5	71.7	52.69%	55.15%
5	D2	150	58.5	69.9	39.00%	46.60%
6	R12	150	42.6	48	28.40%	32.00%
7	Q1 Body	150	62.2	63.9	41.47%	42.60%
8	IC1	150	42.5	44.5	28.33%	29.67%
9	R16	150	74.2	72	49.47%	48.00%
10	R16	150	75.1	77.1	50.07%	51.40%
11	C2	105	70	70.8	66.67%	67.43%
Ambient					--	--

Table 7. Key Parts for Thermal Test

9. EMI

Test Condition:

The power supply should comply with FCC part15,EN 55022 and CISPR22 meeting Class B for conducted emissions with a 3dB margin. Tested unit should be connected to a pure resistor load (rated loding). The test condition shall be followed as:110 VAC(L and N),220VAC(L and N)

Test Result: PASS

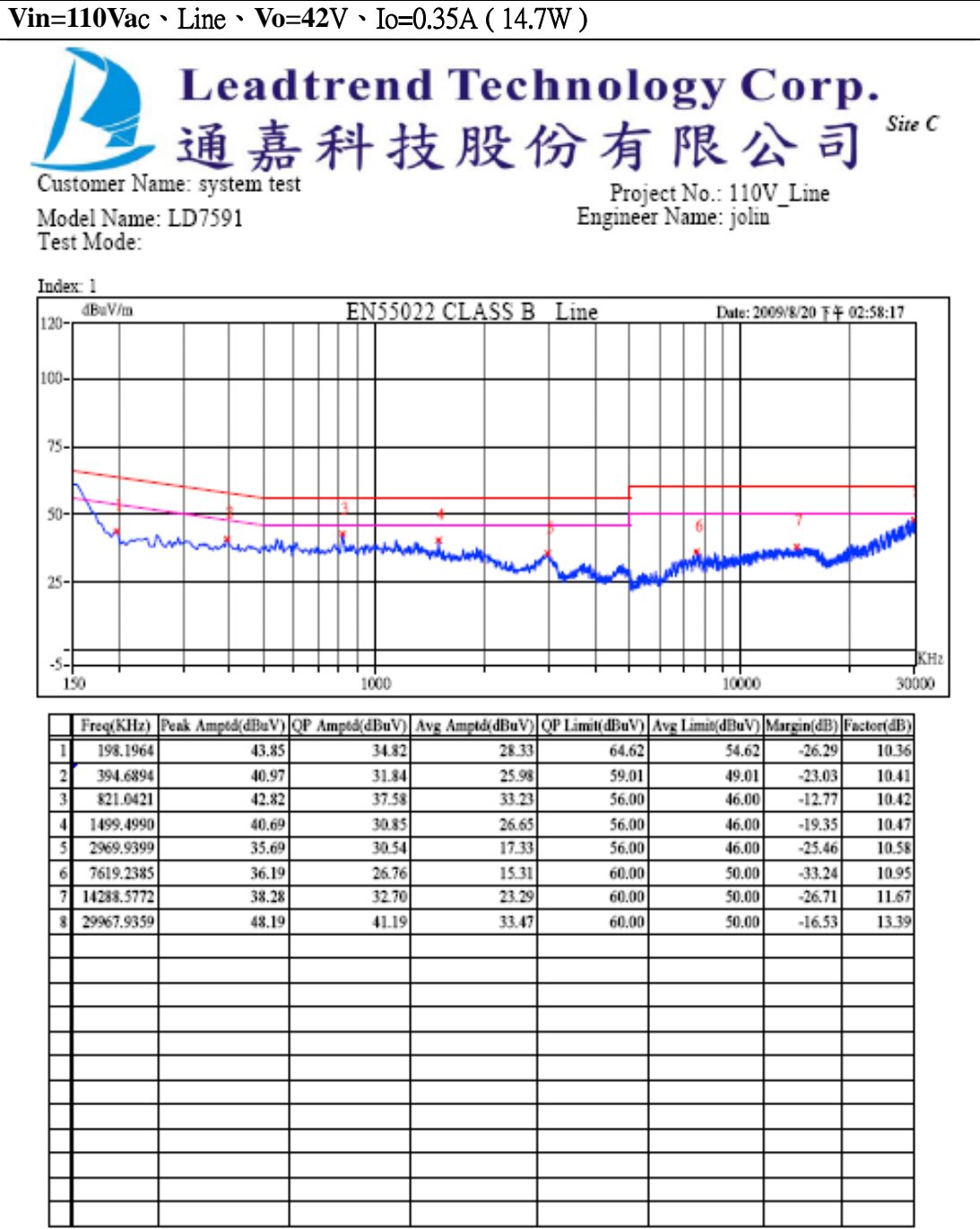

Vin=110Vac、Neutral、Vo=42V、Io=0.35A (14.7W)



Leadtrend Technology Corp.
通嘉科技股份有限公司

Site C

Customer Name: system test

Project No.: 110V_Nature

Model Name: LD7591

Engineer Name: jolin

Test Mode:

Index:

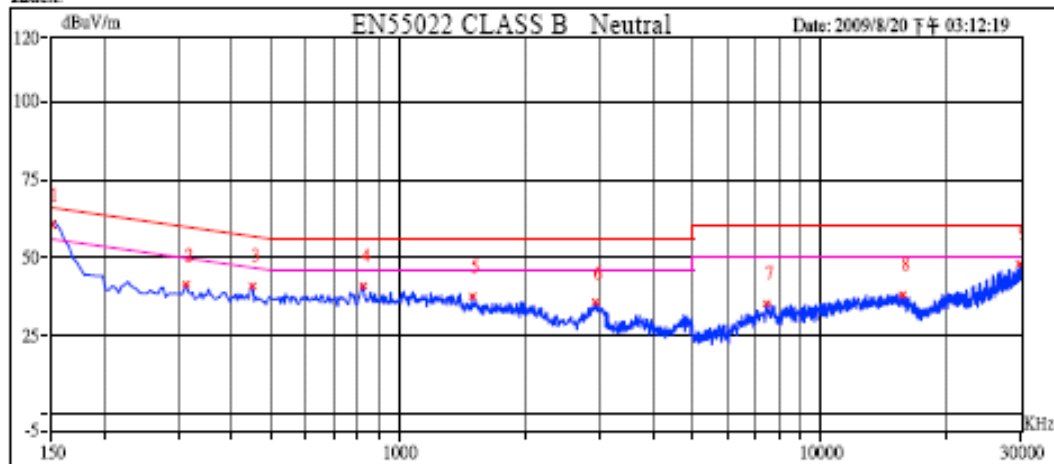

	Freq(KHz)	Peak Amptd(dBuV)	QP Amptd(dBuV)	Avg Amptd(dBuV)	QP Limit(dBuV)	Avg Limit(dBuV)	Margin(dB)	Factor(dB)
1	150.0000	60.96	60.02	47.90	66.00	56.00	-5.98	10.42
2	313.1263	41.48	31.87	26.42	61.34	51.34	-24.92	10.40
3	450.3006	40.94	31.31	25.51	57.42	47.42	-21.91	10.39
4	824.7495	41.16	38.75	34.81	56.00	46.00	-11.19	10.41
5	1499.4990	37.83	34.36	30.89	56.00	46.00	-15.11	10.46
6	2929.8597	35.83	28.33	16.59	56.00	46.00	-27.67	10.56
7	7458.9178	35.25	33.56	18.47	60.00	50.00	-26.44	10.99
8	15747.4950	38.35	35.45	26.56	60.00	50.00	-23.44	12.06
9	29855.7114	48.23	39.98	32.98	60.00	50.00	-17.02	13.98

Vin=220Vac、Line、Vo=42V、Io=0.35A (14.7W)



Leadtrend Technology Corp.

通嘉科技股份有限公司

Site C

Customer Name: system test

Project No.: 220V_Line

Model Name: LD7591

Engineer Name: jolin

Test Mode:

Index: 8

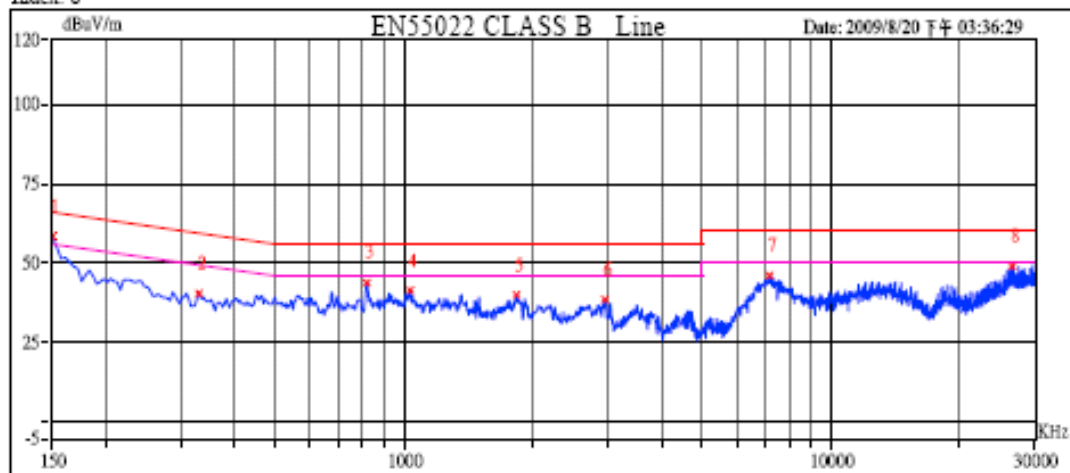

	Freq(KHz)	Peak Amp(dBuV)	QP Amp(dBuV)	Avg Amp(dBuV)	QP Limit(dBuV)	Avg Limit(dBuV)	Margin(dB)	Factor(dB)
1	150.0000	58.53	35.42	34.09	66.00	56.00	-21.91	10.38
2	331.6633	40.68	32.61	26.09	60.81	50.81	-24.72	10.40
3	821.0421	44.10	37.89	33.91	56.00	46.00	-12.09	10.42
4	1032.3647	41.32	35.55	27.19	56.00	46.00	-18.81	10.43
5	1840.5812	40.07	33.25	21.56	56.00	46.00	-22.75	10.50
6	2953.9078	38.61	31.13	17.13	56.00	46.00	-24.87	10.58
7	7202.4048	46.01	41.33	25.50	60.00	50.00	-18.67	10.91
8	26665.3307	49.14	41.57	33.49	60.00	50.00	-16.51	13.02

Vin=220Vac、Neutral、Vo=42V、Io=0.35A (14.7W)



Leadtrend Technology Corp.
通嘉科技股份有限公司

Site C

Customer Name: system test

Project No.: 220V_Nature

Model Name: LD7591

Engineer Name: jolin

Test Mode:

Index: 8

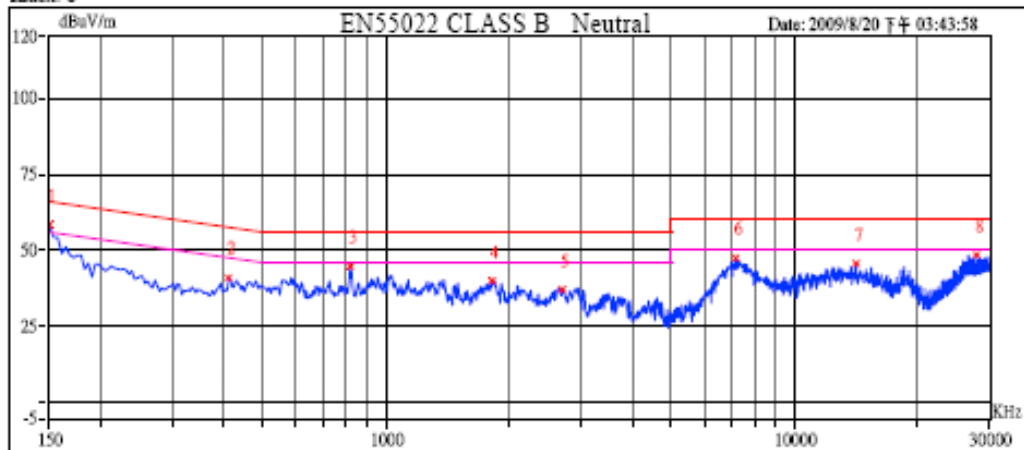

	Freq(KHz)	Peak Amp(dBµV)	QP Amp(dBµV)	Avg Amp(dBµV)	QP Limit(dBµV)	Avg Limit(dBµV)	Margin(dB)	Factor(dB)
1	150.0000	58.50	34.23	31.01	66.00	56.00	-24.99	10.42
2	413.2265	41.02	33.21	25.19	58.48	48.48	-23.29	10.40
3	821.0421	44.67	38.84	34.84	56.00	46.00	-11.16	10.41
4	1825.7515	40.03	35.10	22.25	56.00	46.00	-20.90	10.49
5	2713.4269	37.48	33.53	19.60	56.00	46.00	-22.47	10.54
6	7202.4048	47.55	42.59	26.60	60.00	50.00	-17.41	10.97
7	14160.3206	45.73	38.51	28.49	60.00	50.00	-21.49	11.85
8	27979.9599	48.46	38.37	32.32	60.00	50.00	-17.68	13.72

10. Surge For System
Test Condition:

High Energy Transients are applied to the power supply once each 20 second period with 5 transients per test. The surge Test defines four levels of peak voltage.

Check:

Survival: No component shall be damage electrically during the tests. The PSU shall continue to operate in a safe manner during abnormal operation.

Result:

Input Voltage: 220V (60Hz)

Output Power: Max Load

Surge voltage	Coupling Mode	Test Level	Phase		Repetition	Test Result
1KV	Diff.	±1KV	0	L to N	5 pulses 20Sec	Pass
			90			Pass
			180			Pass
			270			Pass

Table 10

Surge voltage	Coupling Mode	Test Level	Phase		Repetition	Test Result
2KV	COM..	±2KV	0	L to Earth GND N to Earth GND	5 pulses 20Sec	Pass
			90			Pass
			180			Pass
			270			Pass

Table 11

IV. Gerber File:

Silkscreen TOP

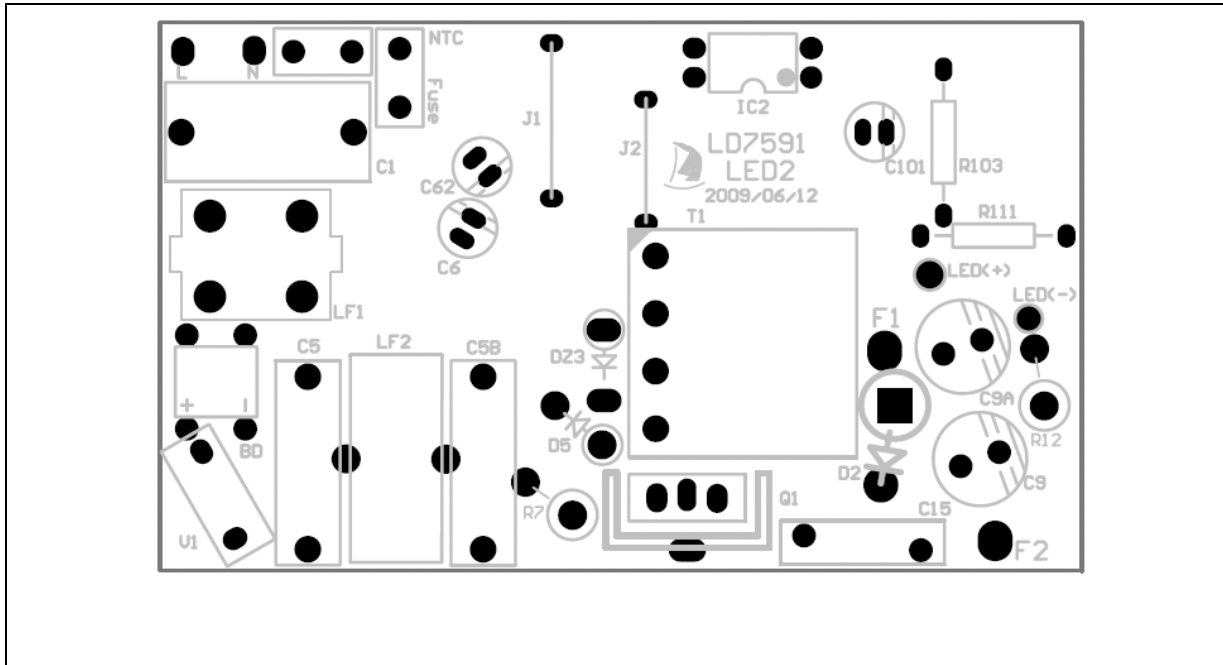

Silkscreen Bottom

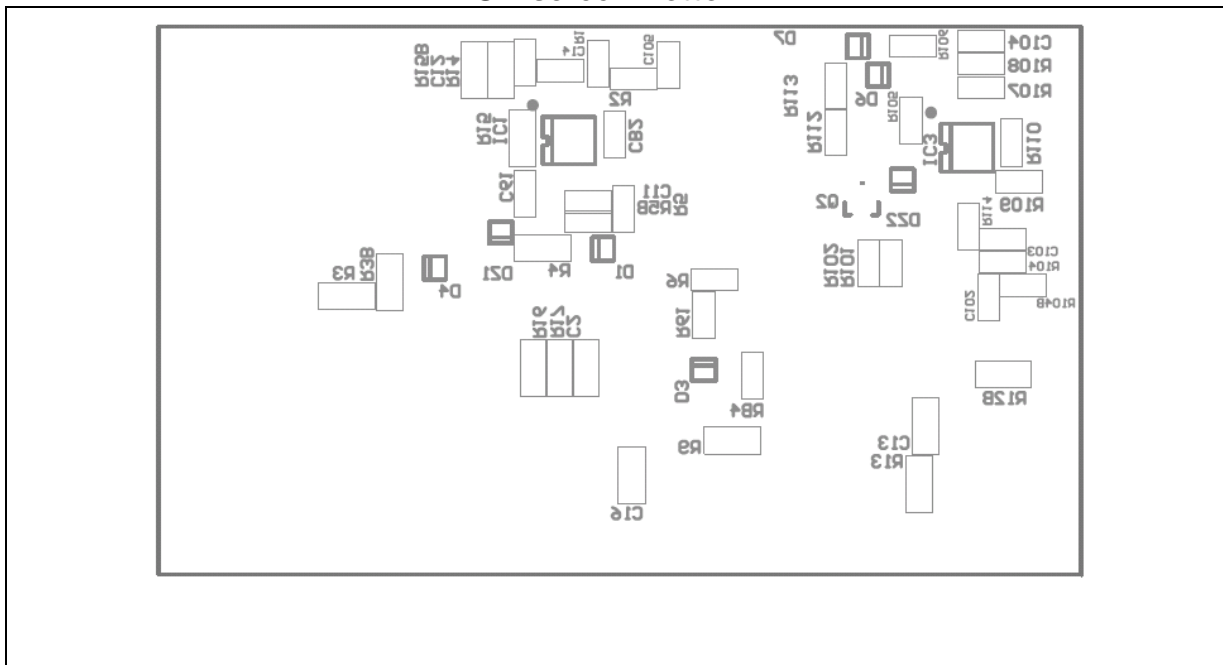

Bottom Layer

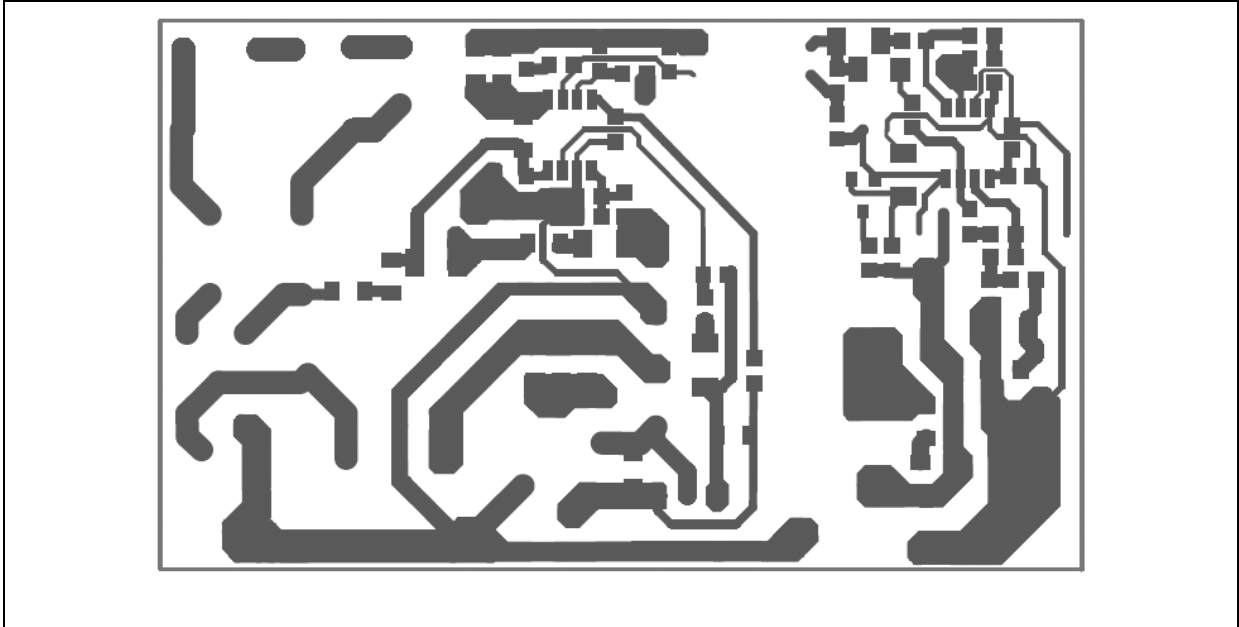

Soldermask Bottom

