

NC-Cap/PSR™ (Primary Side Regulation) CV/CC Controller

FEATURES

- ◆ Direct Drive of Low Cost BJT
- ◆ Proprietary **NC-Cap/PSR™** (Primary Side Regulation) Control without External Compensation/Filtering Capacitor Needed
- ◆ 30KHz Max. Frequency Clamping @ Output Short Circuit
- ◆ $\pm 5\%$ Constant Current (CC) and Constant Voltage (CV) Regulation at Universal AC Input
- ◆ Proprietary Cable Voltage Drop Compensation in CV Mode
- ◆ Low Standby Power Under 70mW
- ◆ Compensate for Transformer Inductance Tolerances and Line Voltage Variation
- ◆ Pin Floating Protection
- ◆ Cycle-by-Cycle Current Limiting
- ◆ Built-in Leading Edge Blanking (LEB)
- ◆ Built-in Soft Start
- ◆ Output Over Voltage Protection
- ◆ VDD OVP & Clamp
- ◆ VDD Under Voltage Lockout (UVLO)

APPLICATIONS

- ◆ Battery chargers for cellular phones, cordless phones, PDA, digital cameras, etc
- ◆ Replaces linear transformer and RCC SMPS
- ◆ Small power adapter
- ◆ AC/DC LED lighting

GENERAL DESCRIPTION

SF6010 is a high precision, highly integrated DCM (Discontinuous Conduction Mode) Primary Side Regulation (PSR) controller for offline small power converter applications. It can directly drive power BJT, which can further lower system cost.

SF6010 uses **Multi Mode Control** to improve efficiency and reliability and to decrease audio noise energy @ light loadings. Around the full load, the system operates in PWM+PFM mode, which improve the system reliability. Under light load conditions, the IC operates in PFM mode to achieve excellent regulation and high efficiency, and to achieve less than 70mW standby power. SF6010 also integrates the function of "**Max. Frequency Clamping @ Output Short Circuit**" to limits power BJT Vce spike when output short circuits occurs.

SF6010 has built-in proprietary **NC-Cap/PSR™** control for CV control, which eliminates external compensation or filtering capacitor. It has built-in cable drop compensation function, which can provide excellent CV performance.

SF6010 integrates functions and protections of Under Voltage Lockout (UVLO), VDD Over Voltage Protection (VDD OVP), Output Over Voltage Protection (Output OVP), Soft Start, Cycle-by-cycle Current Limiting (OCP), Pin Floating Protection, VDD Clamping.

SF6010 is available in SOT23-5 and SOT23-6 packages.

TYPICAL APPLICATION

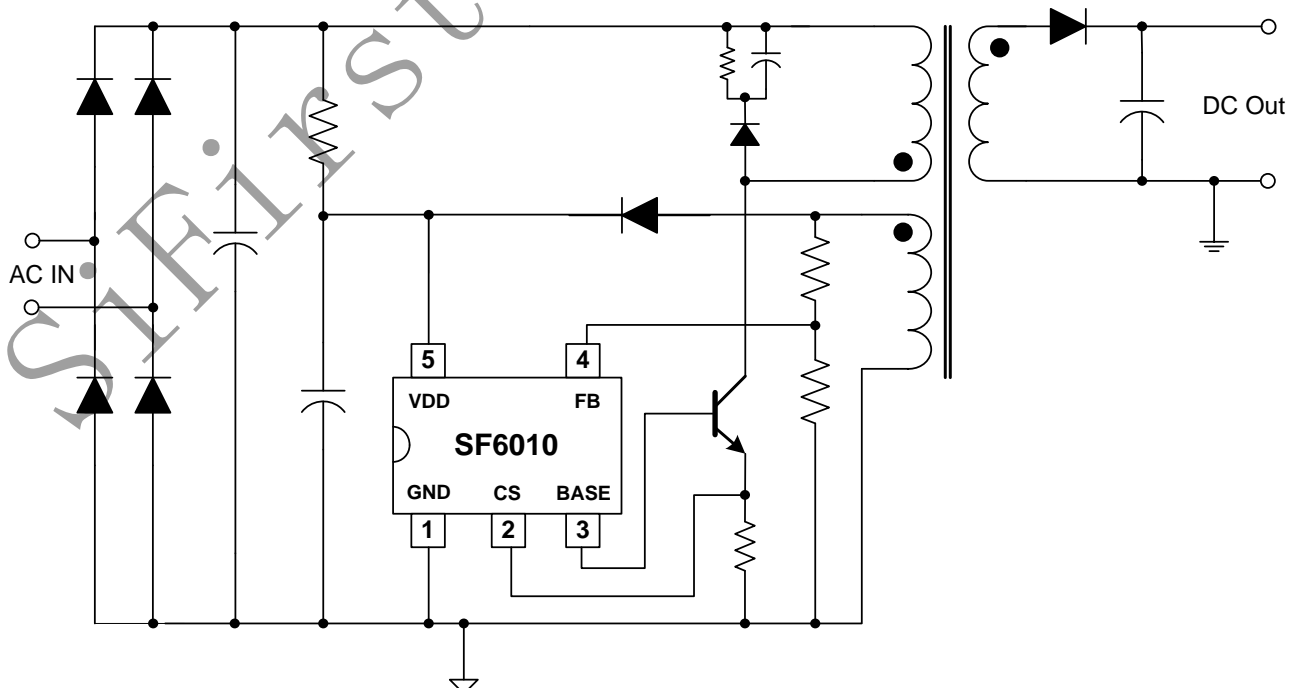

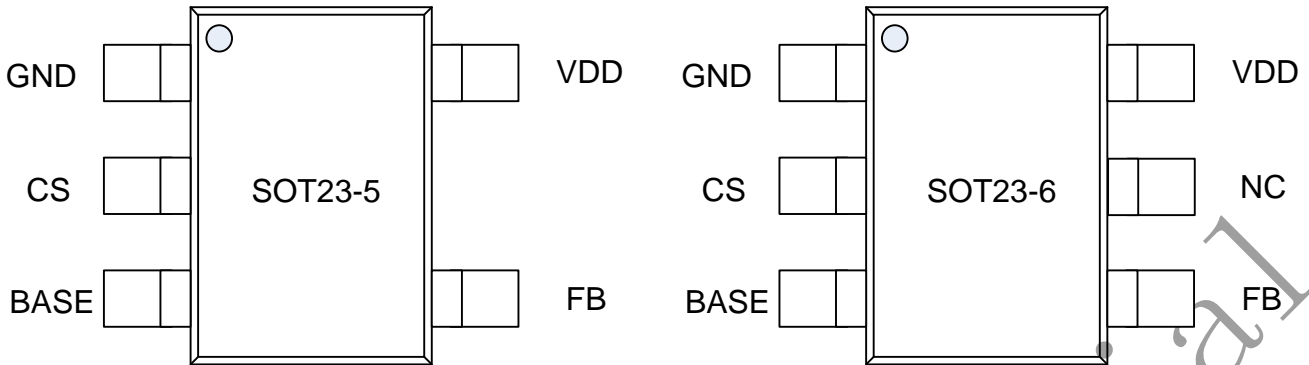
Pin Configuration

Ordering Information

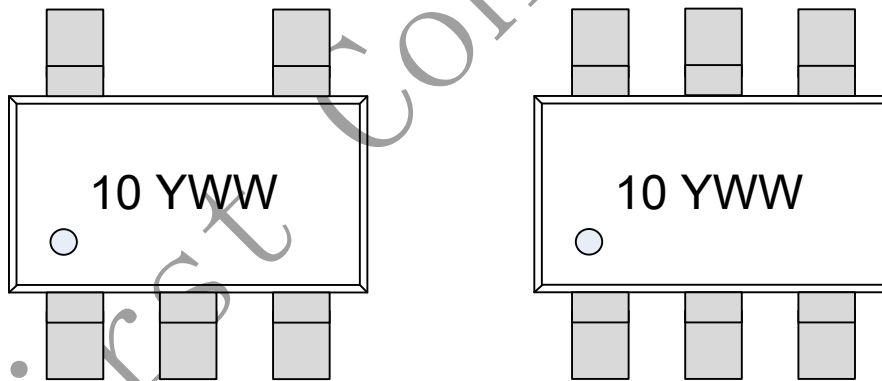
Part Number	Top Mark	Package		Tape & Reel
SF6010MGT	.10YWW	SOT23-5	Green	Yes
SF6010LGT	.10YWW	SOT23-6	Green	Yes

Marking Information

Dot: Pin1 Mark
YWW: Year & Week Code

Pin Description

Pin Num	Pin Name	I/O	Description
1	GND	P	Ground
2	CS	I	Current sense pin.
3	BASE	O	Base drive for BJT.
4	FB	I	System feedback pin. This control input regulates both the output voltage in CV mode and output current in CC mode based on the flyback voltage of the auxiliary winding.
5	VDD	P	IC power supply pin.

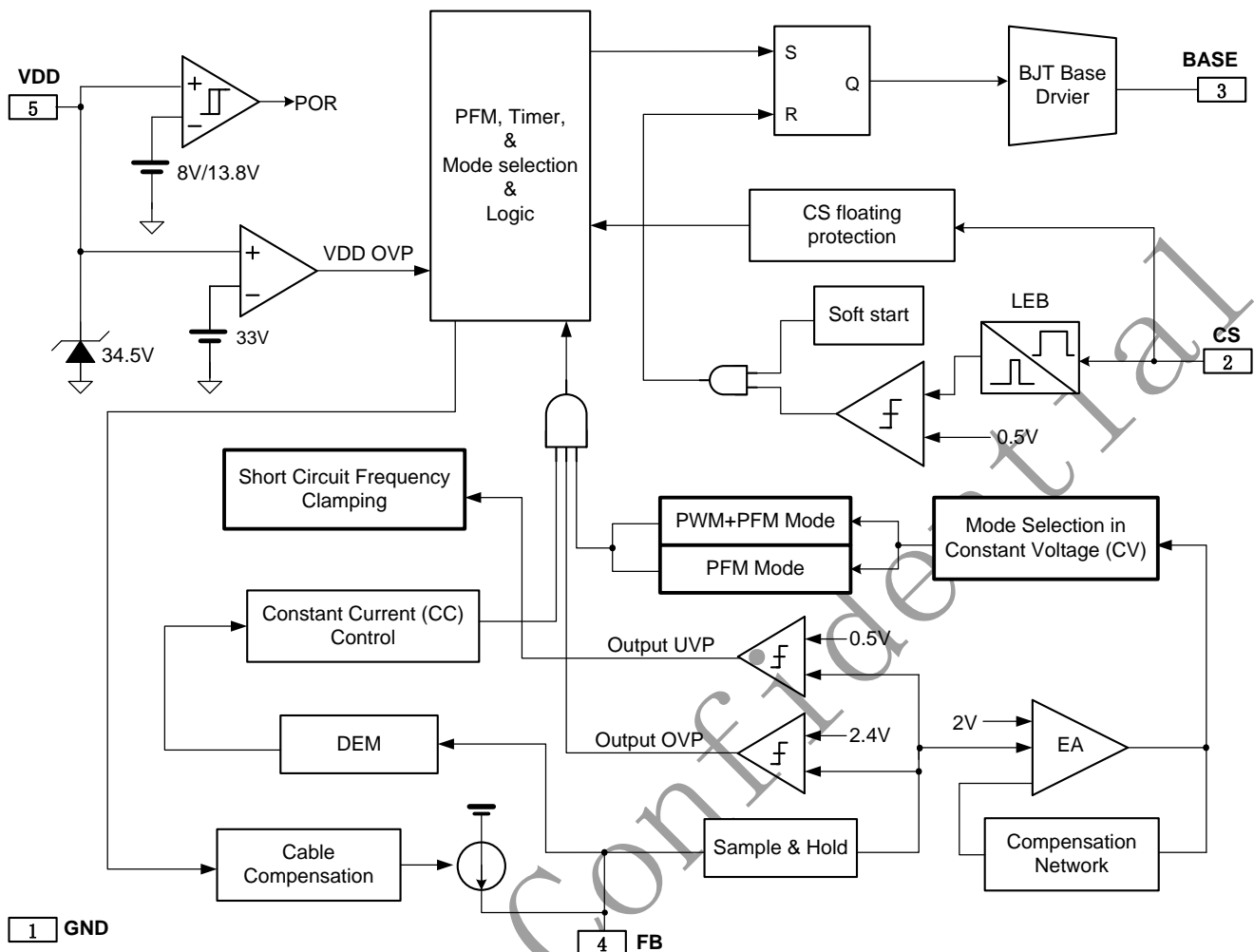
Block Diagram

Absolute Maximum Ratings (Note 1)

Parameter	Value	Unit
VDD DC Supply Voltage	34.5	V
VDD DC Clamp Current	10	mA
CS, BASE Voltage Range	-0.3 to 7	V
FB Voltage Range	-0.7 to 7	V
Package Thermal Resistance (SOT-23-5)	300	°C/W
Package Thermal Resistance (SOT-26)	250	°C/W
Maximum Junction Temperature	150	°C
Operating Temperature Range	-40 to 85	°C
Storage Temperature Range	-65 to 150	°C
Lead Temperature (Soldering, 10sec.)	260	°C
ESD Capability, HBM (Human Body Model)	3	kV
ESD Capability, MM (Machine Model)	250	V

Recommended Operation Conditions (Note 2)

Parameter	Value	Unit
Supply Voltage, VDD	10 to 30	V
Operating Ambient Temperature	-40 to 85	°C
Maximum Switching Frequency	70K	Hz

ELECTRICAL CHARACTERISTICS

 (T_A = 25°C, VDD=18V, if not otherwise noted)

Symbol	Parameter	Test Conditions	Min	Typ	Max	Unit
Supply Voltage (VDD) Section						
I_Startup	VDD Start up Current	VDD =UVLO(ON)-1V, Measure current into VDD		3	20	uA
I_VDD_Op	Operation Current	VDD=20V		1	1.5	mA
UVLO(ON)	VDD Under Voltage Lockout Exit (Startup)		12.8	13.8	14.8	V
UVLO(OFF)	VDD Under Voltage Lockout Enter		7	8	9	V
VDD_OVP	VDD Over Voltage Protection trigger		31	33	35	V
V _{DD} _Clamp	VDD Zener Clamp Voltage	I(V _{DD}) = 10 mA	33.5	34.5	35.5	V
T_Softstart	Soft Start Time			2		mSec
Feedback Input Section(FB Pin)						
V _{FB_EA_Ref}	Internal Error Amplifier(EA) reference input		1.98	2.0	2.02	V
V _{FB_OVP}	Output over voltage protection threshold			2.4		V
V _{FB_DEM}	Demagnetization comparator threshold			0.1		V
T _{min_OFF}	Minimum OFF time			2		uSec
T _{max_OFF}	Maximum OFF time			3		mSec
V _{FB_UVP}	Output under voltage protection threshold			0.5		V
F _{Clamp_Short}	Max frequency @ Output Short Circuit			30		KHz
T _{CC} /T _{DEM}	Ratio between switching period in CC mode and demagnetization time			2		
I _{Cable_max}	Max Cable compensation current			40		uA
Current Sense Input Section (CS Pin)						
T _{blanking}	CS Input Leading Edge Blanking Time			500		nSec
V _{th_OC_max}	Max. Current limiting threshold		490	500	510	mV
T _{D_OC}	Over Current Detection and Control Delay			100		nSec
Base Drive Section (BASE Pin)						
I _{BASE_max}	Max. Base Sourcing Current		25	30	35	mA
I _{BASE_pre_OFF}	Base Sourcing Current after Pre-off		0.5	1	1.5	mA
R _{dson_low}	Output Low Level ON Resistance			1		Ω

Note 1. Stresses beyond those listed under “Absolute Maximum Ratings” may cause permanent damage to the device. These are stress ratings only, and functional operation of the device at these or any other conditions beyond those indicated in the operational sections of the specifications is not implied. Exposure to absolute maximum rating conditions for extended periods may affect device reliability.

Note 2. The device is not guaranteed to function outside its operating conditions.

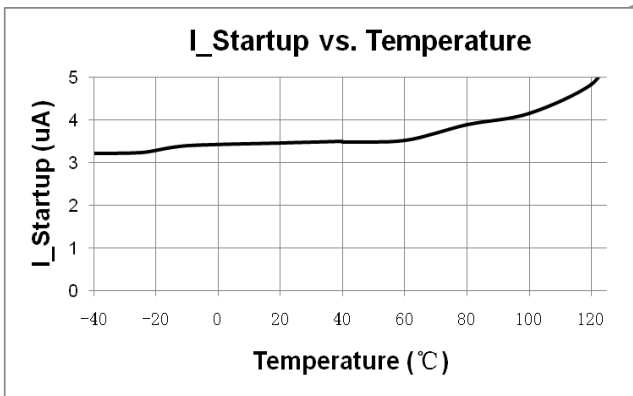
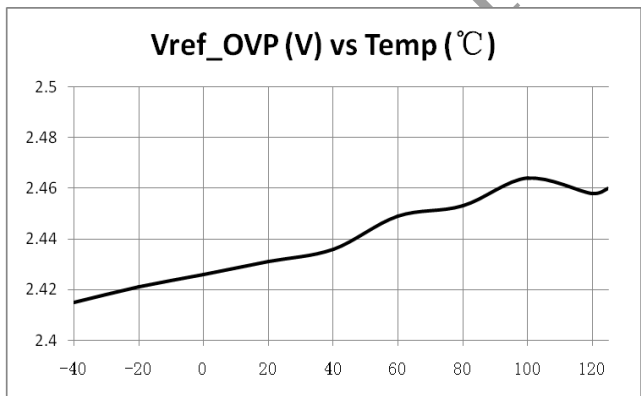
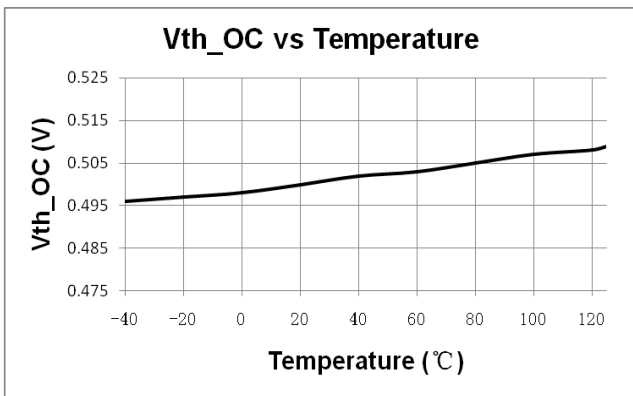
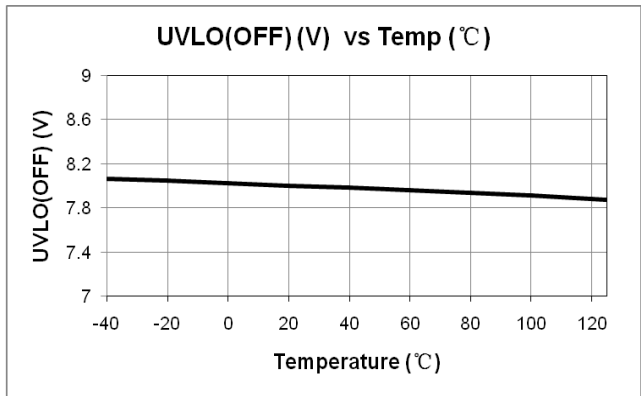
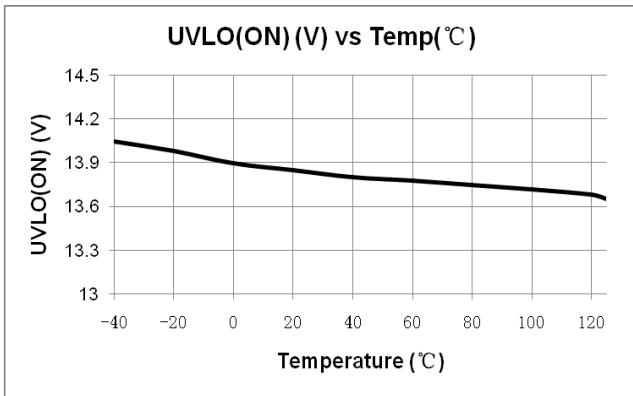
CHARACTERIZATION PLOTS

OPERATION DESCRIPTION

SF6010 is a high performance, highly integrated DCM (Discontinuous Conduction Mode) Primary Side Regulation (PSR) controller. The built-in high precision CV/CC control makes it very suitable for offline small power converter applications.

◆ PSR Technology Introduction

Assuming the system works in DCM mode, the power transfer function is given by

$$P = \frac{\eta}{2} \times L_m \times I_{pk}^2 \times f_s = V_o \times I_o \quad (\text{Eq.1})$$

In the equation above, P is output power, Vo and Io are system output voltage and current respectively, η is system power transfer efficiency, Lm is transformer primary inductance, fs is system switching frequency, Ipk is primary peak current in a switching cycle. The following figure illustrates the waveform in a switching cycle.

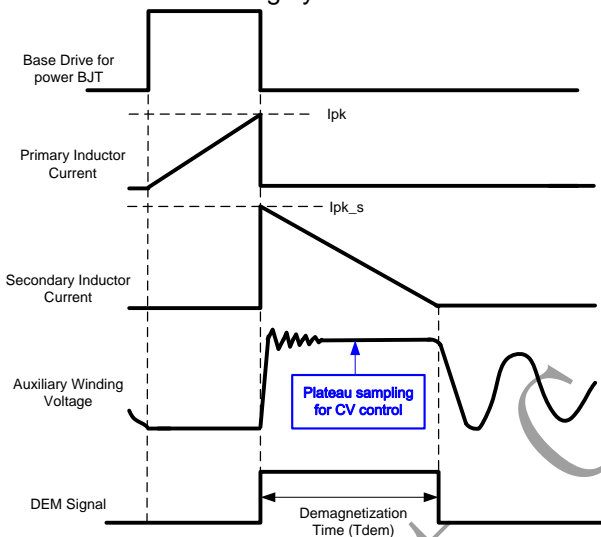

Fig.1

In the figure shown above, the IC generates a demagnetization signal (DEM) in each switching cycle through auxiliary winding. Tdem is demagnetization time for CV/CC control. In DCM mode, Tdem can be expressed as;

$$\frac{V_o}{L_m} \times T_{dem} = \frac{N_s}{N_p} \times I_{pk} \quad (\text{Eq.2})$$

In Eq.2, Np and Ns are primary and secondary winding turns respectively.

Combined with Eq.1 and Eq. 2, the average output current can be expressed as:

$$I_o = \frac{\eta}{2} \times I_{pk} \times \frac{N_p}{N_s} \times f_s \times T_{dem} \quad (\text{Eq.3})$$

CC (Constant Current) Control Scheme

From Eq.3, it can be easily seen that there are two ways to implement CC control: one is PFM (Pulse Frequency Modulation), the control scheme is to keep Ipk to be constant, let the product of Ts and Tdem (fs*Tdem) to be a constant. In this way, Io

will be a value independent to the variation of Vo, Lm, and line input voltage. Another realization method is PWM duty control, the control scheme is to keep fs to be constant, let the product of Tdem and Ipk (Tdem*Ipk) to be a constant, in another words, by modulating system duty cycle to realize a constant Io independent to the variation of Vo, Lm and line voltages.

SF6010 adopts PFM for CC control, the product of Ts and Tdem is given by

$$f_s \times T_{dem} = 0.5 \quad (\text{Eq.4})$$

CV (Constant Voltage) Control Scheme

CV control should sample the plateau of auxiliary winding voltage in flyback phase, as shown in Fig.1 The CV control has many implementations, for example, PWM, or PFM, or a combination of both one. In SF6010, the CV control adopts proprietary multi mode control, as mention below.

◆ NC-Cap/PSR™ Eliminates External Compensation/Filtering Capacitor

SF6010 uses a proprietary control to eliminate external compensation capacitor, which can simplify system design and lower system cost.

◆ Precision CV/CC Performance

In SF6010, the parameters are trimmed to tight range, which makes the system CC/CV to have less than 5% variation.

◆ Multi Mode Control for High Reliability , High Efficiency, and Audio Noise Free Operation

Conventional pure PFM system may suffer transformer saturation issue when heavy loading. In SF6010, a proprietary multi mode control is adopted to suppress this issue, as shown in Fig.2.

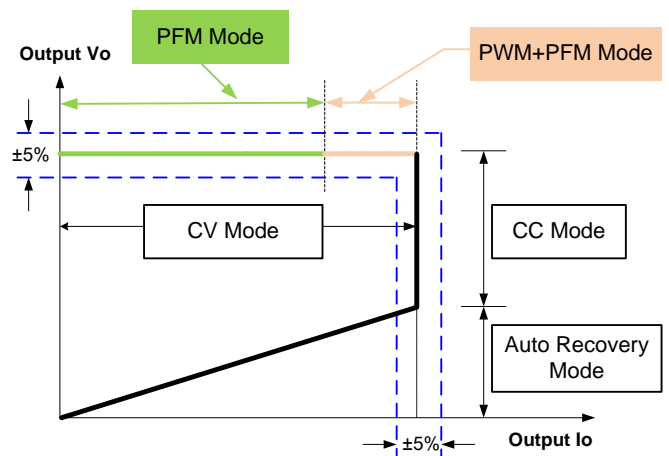

Fig.2

Around the full load, the system operates in PWM+PFM mode, which improve the system reliability. Under normal to light load conditions, the

IC operates in PFM mode to achieve excellent regulation and high efficiency, yet meets the requirement for no-load consumption less than 70mW, as shown in Fig.2

Multi mode control can also reduce audio noise in lighting loadings, compared to conventional pure PFM control.

◆ **Startup Current and Startup Control**

Startup current of SF6010 is designed to be very low (typically 3uA) so that VDD could be charged up above UVLO(ON) threshold level and device starts up quickly. A large value startup resistor can therefore be used to minimize the power loss yet reliable startup in application.

◆ **Operating Current**

The operating current in SF6010 is as small as 1mA (typical). The small operating current results in higher efficiency and reduces the VDD hold-up capacitance requirement.

◆ **Soft Start**

SF6010 features an internal 2ms (typical) soft start that slowly increases the threshold of cycle-by-cycle current limiting comparator during startup sequence. Every startup process is followed by a soft start activation.

◆ **Proprietary Cable Voltage Drop Compensation in CV Mode**

When it comes to cellular phone charger applications, the battery is located at the end of cable, which causes typically several percentage of voltage drop on the actual battery voltage. SF6010 has a proprietary built-in cable voltage drop compensation block which can provide a constant output voltage at the end of the cable over the entire load range in CV mode.

◆ **Leading Edge Blanking (LEB)**

Each time the power BJT is switched on, a turn-on spike occurs across the sensing resistor. To avoid premature termination of the switching pulse, an internal leading edge blanking circuit is built in. During this blanking period (500ns, typical), the cycle-by-cycle current limiting comparator is disabled and cannot switch off the base driver. Thus, external RC filter with a small time constant is enough for current sensing.

◆ **Minimum and Maximum OFF Time**

In SF6010, a minimum OFF time (typically 2us) is implemented to suppress ringing when BASE drive is pull off. The maximum OFF time in SF6010 is typically 3ms, which provides a large range for frequency reduction. In this way, a low standby power of 70mW can be achieved.

◆ **Output OVP(Over Voltage Protection)**

In SF6010, the output Over Voltage Protection (OVP) is integrated by plateau sampling the auxiliary winding in flyback phase. When sampled FB voltage achieves to 2.4V, the system will enter into auto recovery mode protection (mentioned below), as shown in Fig.3. When sensed FB voltage is below 0.5V, the IC will enter into Under Voltage Protection (UVP) mode, in which the maximum switching frequency is clamped (mentioned below).

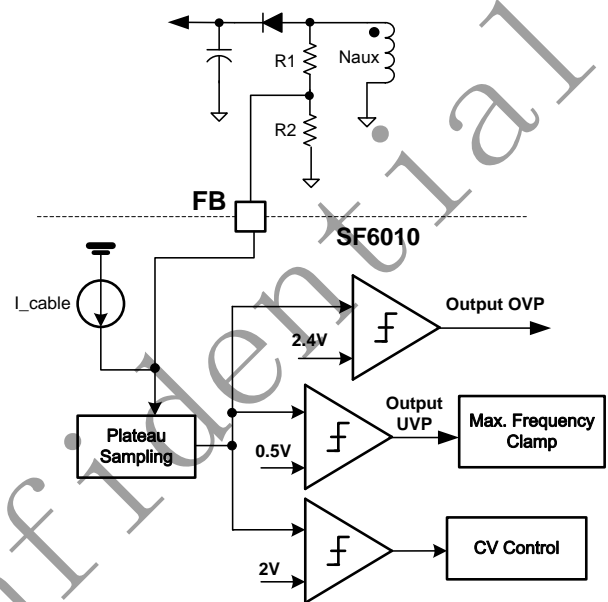

Fig.3

◆ **Pin Floating Protection**

In SF6010, if pin floating situation occurs, the IC is designed to have no damage to system.

◆ **VDD OVP(Over Voltage Protection)**

VDD OVP (Over Voltage Protection) is implemented in SF6010 and it is a protection of auto-recovery mode.

◆ **Maximum Frequency Clamping @ Output Short Circuit**

In SF6010, when FB voltage is below 0.5V, the IC will enter into Under Voltage Protection (UVP) mode, the PFM switching frequency is clamped to 30KHz (typical). This protection is useful for LED short circuit protection. When output short, the frequency clamping can lower power BJT voltage spike and the system reliability can be improved, as shown in Fig.4

Vce @ Output Short Circuit

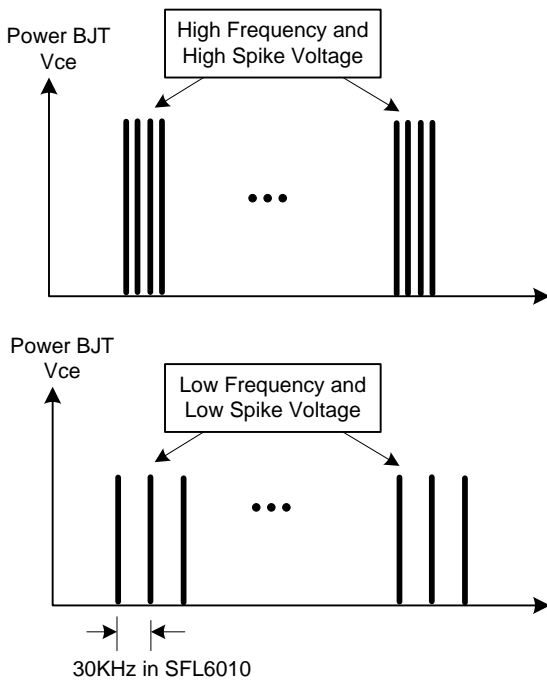

Fig.4

◆ **Auto Recovery Mode Protection**

As shown in Fig.5, once a fault condition is detected, switching will stop. This will cause VDD to fall because no power is delivered from the auxiliary winding. When VDD falls to UVLO(off) (typical 8V), the protection is reset and the

operating current reduces to the startup current, which causes VDD to rise, as shown in Fig.5. However, if the fault still exists, the system will experience the above mentioned process. If the fault has gone, the system resumes normal operation. In this manner, the auto restart can alternatively enable and disable the switching until the fault condition is disappeared.

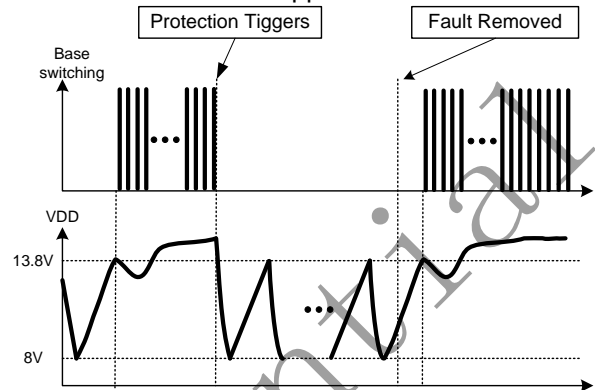
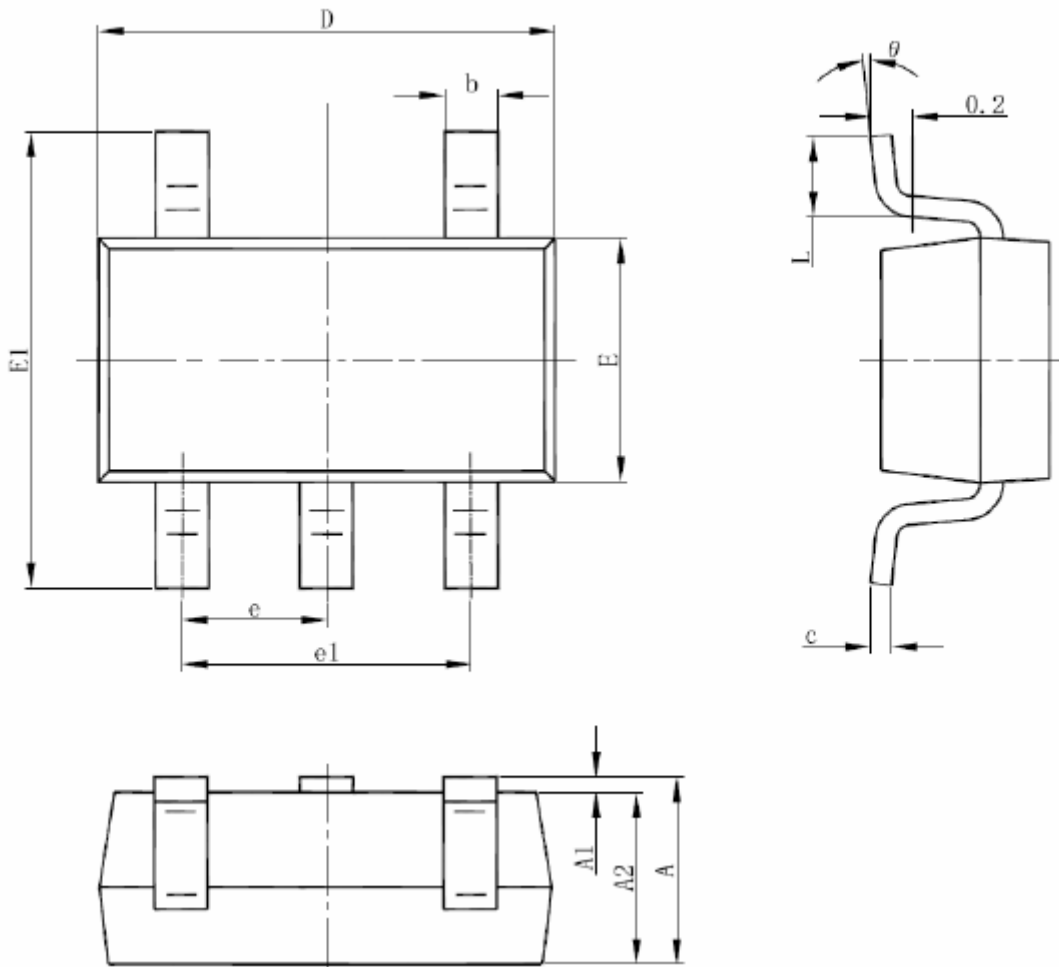

Fig.5

◆ **Base Drive**

SF6010 can directly drive external power BJT. The maximum base drive current is typical 30mA. The base drive current is dynamic controlled to optimize performance.

PACKAGE MECHANICAL DATA
SOT-23-5L PACKAGE OUTLINE DIMENSIONS

Symbol	Dimensions In Millimeters		Dimensions In Inches	
	Min	Max	Min	Max
A	1.050	1.250	0.041	0.049
A1	0.000	0.100	0.000	0.004
A2	1.050	1.150	0.041	0.045
b	0.300	0.500	0.012	0.020
c	0.100	0.200	0.004	0.008
D	2.820	3.020	0.111	0.119
E	1.500	1.700	0.059	0.067
E1	2.650	2.950	0.104	0.116
e	0.950 (BSC)		0.037 (BSC)	
e1	1.800	2.000	0.071	0.079
L	0.300	0.600	0.012	0.024
θ	0°	8°	0°	8°

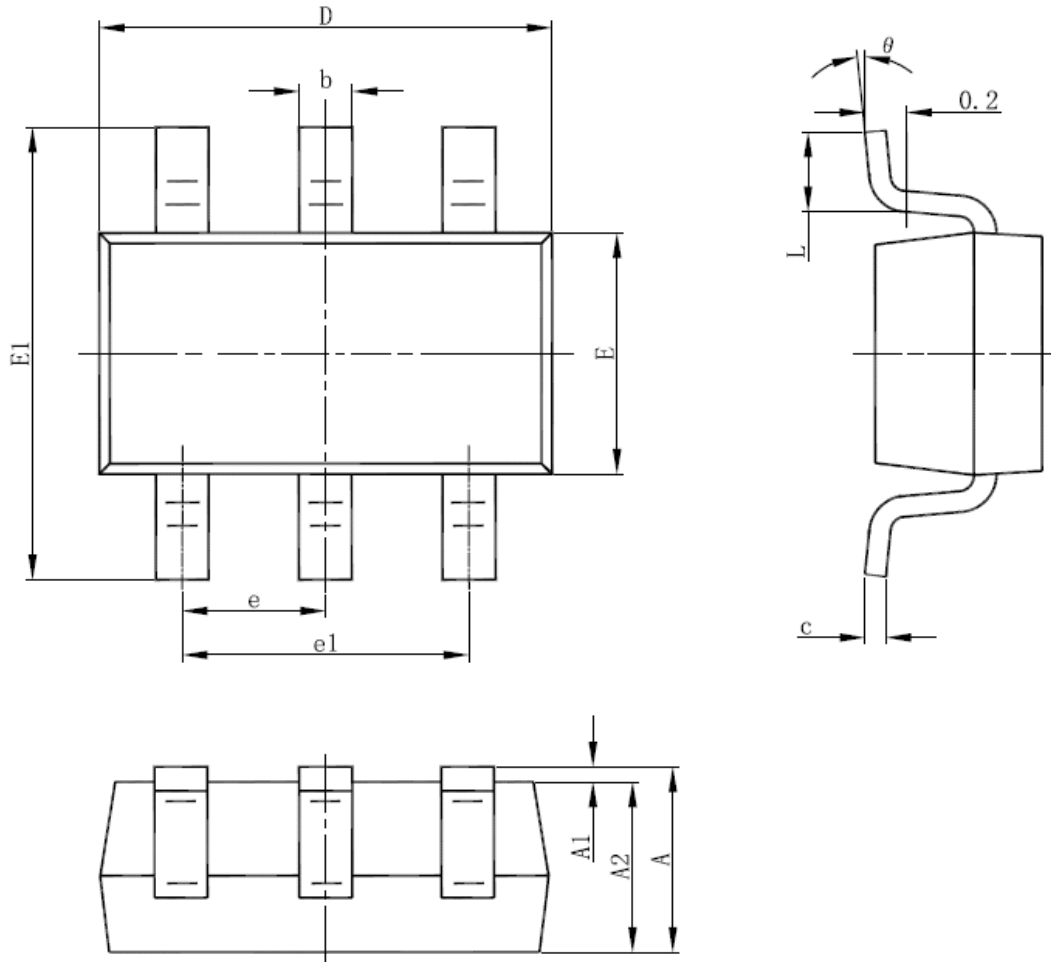
PACKAGE MECHANICAL DATA
SOT-23-6L PACKAGE OUTLINE DIMENSIONS

Symbol	Dimensions In Millimeters		Dimensions In Inches	
	Min	Max	Min	Max
A	1.000	1.300	0.039	0.051
A1	0.000	0.150	0.000	0.006
A2	1.000	1.200	0.039	0.047
b	0.300	0.500	0.012	0.020
c	0.100	0.200	0.004	0.008
D	2.800	3.020	0.110	0.119
E	1.500	1.700	0.059	0.067
E1	2.600	3.000	0.102	0.118
e	0.950 (BSC)		0.037 (BSC)	
e1	1.800	2.000	0.071	0.079
L	0.300	0.600	0.012	0.024
θ	0°	8°	0°	8°

IMPORTANT NOTICE

SiFirst Technology Nanhai, Ltd (SiFirst) reserves the right to make corrections, modifications, enhancements, improvements and other changes to its products and services at any time and to discontinue any product or service without notice. Customers should obtain the latest relevant information before placing orders and should verify that such information is current and complete.

SiFirst warrants performance of its hardware products to the specifications applicable at the time of sale in accordance with SiFirst's standard warranty. Testing and other quality control techniques are used to the extent SiFirst deems necessary to support this warranty. Except where mandated by government requirements, testing of all parameters of each product is not necessarily performed.

SiFirst assumes no liability for application assistance or customer product design. Customers are responsible for their products and applications using SiFirst's components. To minimize the risks associated with customer products and applications, customers should provide adequate design and operating safeguards.

Reproduction of SiFirst's information in SiFirst's data books or data sheets is permissible only if reproduction is without alteration and is accompanied by all associated warranties, conditions, limitations, and notices. Reproduction of this information with alteration is an unfair and deceptive business practice. SiFirst is not responsible or liable for such altered documentation. Information of third parties may be subject to additional restrictions.

Resale of SiFirst's products or services with statements different from or beyond the parameters stated by SiFirst for that product or service voids all express and any implied warranties for the associated SiFirst's product or service and is an unfair and deceptive business practice. SiFirst is not responsible or liable for any such statements.

SiFirst's products are neither designed nor intended for use in military applications. SiFirst will not be held liable for any damages or claims resulting from the use of its products in military applications.

SiFirst's products are not designed to be used as components in devices intended to support or sustain human life. SiFirst will not be held liable for any damages or claims resulting from the use of its products in medical applications.