

ACT2801 Demo Board Application Report

Dedicated Power Bank Solution

FEATURES

- 5V/1.5A input current limit
- 1.0A battery charge current
- 5V/1.2A boost output current
- 1.4A boost output constant current limit
- 5.0V+/- 100mV output voltage
- Programmable 4.1V to 4.35V battery voltage
- Single chip integration solution with minimal component count
- Prioritized power path from input to output
- 92% charge efficiency and 94.5% efficiency for boost
- Accommodation for 10mA-2100mA input source
- Battery disconnected at output short to ground
- 1.1MHz switching frequencies allowing 2.2μH inductor
- <10uA battery drain current in HZ mode
- Boost shuts down at no load and turns on by push button
- 4 LEDs indicating battery level and charge status with impedance compensation
- Preconditioning, fast charge, top off and end of charge in battery charge mode
- Battery temperature monitoring and thermal protection
- 4.6V battery over voltage protection
- Charge current foldback at 110°C die temperature
- IC over temperature protection
- TQFN4x4-24 package

SPECIFICATION

Input voltage	Boost output voltage	Input current limit	Battery charge current	Boost output current limit
4.7 - 5.5V	5.0V	1.5A	1A	1.4A

TABLE OF CONTENT

1	DEMO BOARD PHOTOS	3
2	SCHEMATIC	3
3	BILL OF MATERIALS	4
4	PCB LAYOUT	5
5	FUNCTIONAL TEST	5
5.1	BATTERY CHARGE V/I PROFILE	5
5.2	POWER PATH FUNCTION	5
5.3	CHARGE EFFICIENCY	6
5.4	BOOST OUTPUT REGULATION (MEASURED AT USB PORT).....	6
5.5	BOOST EFFICIENCY AND POWER LOSS (TA=25°C).....	7
5.6	BOOST STANDBY POWER (TA=25°C)	8
5.7	BOOST CONSTANT CURRENT AND CONSTANT VOLTAGE REGULATION (TA=25°C)	8
5.8	BATTERY LEAKAGE CURRENT IN HZ MODE	9
5.9	RIPPLE AND NOISE.....	9
5.10	LOAD DYNAMIC RESPONSE LOAD STEP	10
5.11	LED INDICATION	10
5.12	SYSTEM MANAGEMENT.....	11
5.13	KEY COMPONENTS TEMPERATURE TEST (TA=40°C, BURNING FOR 2 HOURS)	11
6	PCB LAYOUT GUIDANCE	12
7	EMI TEST	13

1 DEMO BOARD PHOTOS

(DEMO BOARD SIZE: 37.2mm*15.5mm)

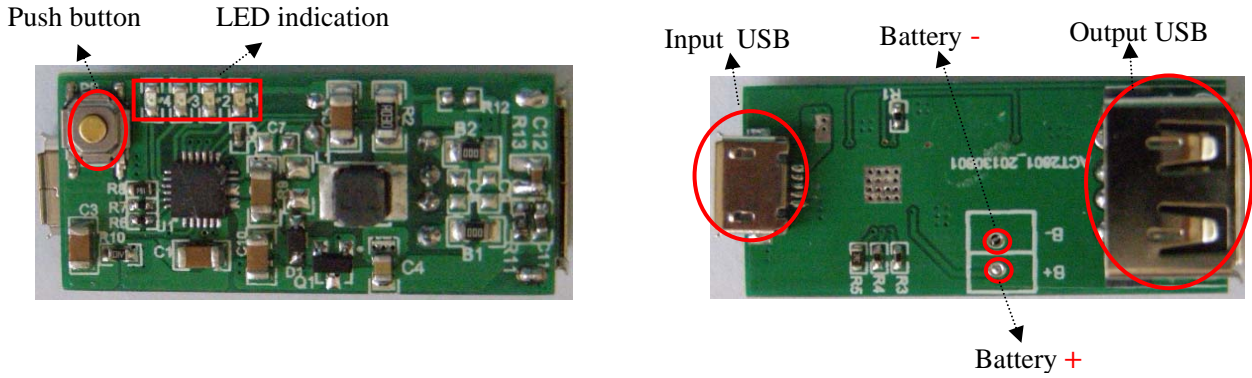

2 SCHEMATIC

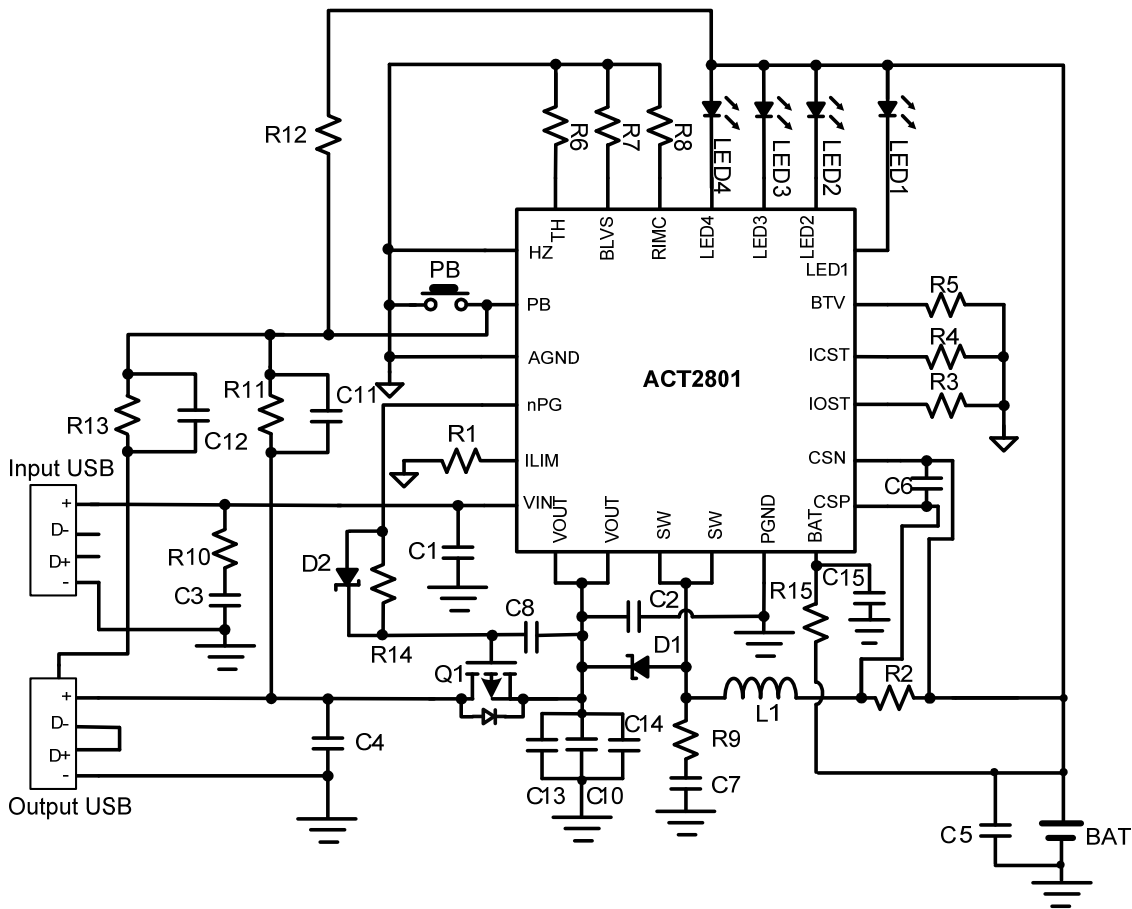

3 BILL OF MATERIALS

Item	Reference	Description	QTY	Manufacturer
1	L1	SWPA4020S1R0NT 2.2uH 3.4A (4*4*2mm)	1	Sunlord
2	Q1	SI2365EDS, Rdson=32mΩ at VGS = - 4.5 V	1	Vishay
3	D1,D2	ZLLS410, 1A/10V, Vf=0.5V@I=1A	2	Diodes
4	C1,C2,C3,C5,C10,C13,C14	Ceramic capacitor, 22uF/10V, X7R, 1206	7	Murata/TDK
5	C4,C8	Ceramic capacitor, 0.1uF/10V, X7R, 0603	2	Murata/TDK
6	C6	Ceramic capacitor, 10nF/6.3V, X7R, 0402	1	Murata/TDK
7	C7	Ceramic capacitor, 1nF/6.3V, X7R, 0603	1	Murata/TDK
8	C11,C15	Ceramic capacitor, 2.2uF/6.3V, X7R, 0603	2	Murata/TDK
9	C12	Ceramic capacitor, 4.7uF/6.3V, X7R, 0603	1	Murata/TDK
10	R1	Chip Resistor, 1.5kΩ, 1/16W, 1%, 0402	1	Murata/TDK
11	R2	Chip Resistor, 30mΩ, 1/2W, 1%, 1210	1	Murata/TDK
12	R3	Chip Resistor, 64.9kΩ, 1/16W, 1%, 0402	1	Murata/TDK
13	R4	Chip Resistor, 24.9kΩ, 1/16W, 1%, 0402	1	Murata/TDK
14	R5	Chip Resistor, 25kΩ, 1/16W, 1%, 0402	1	Murata/TDK
15	R6	Chip Resistor, 10kΩ, 1/16W, 1%, 0402	1	Murata/TDK
16	R7	Chip Resistor, 60kΩ, 1/16W, 1%, 0402	1	Murata/TDK
17	R8	Chip Resistor, 80kΩ, 1/16W, 1%, 0402	1	Murata/TDK
18	R9	Chip Resistor, 5.1Ω, 1/10W, 5%, 0603	1	Murata/TDK
19	R10	Chip Resistor, 1Ω, 1/10W, 5%, 0603	1	Murata/TDK
20	R11	Chip Resistor, 200kΩ, 1/10W, 5%, 0603	1	Murata/TDK
21	R12,R13	Chip Resistor, 715kΩ, 1/10W, 5%, 0603	2	Murata/TDK
22	R14	Chip Resistor, 4.7kΩ, 1/10W, 5%, 0603	1	Murata/TDK
23	R15	Chip Resistor, 22Ω, 1/10W, 5%, 0402	1	
24	LED1,LED2,LED3,LED4	LED, 0603, Blue	4	LED Manu
25	USB	10.2*14.6*7mm, 4P	1	
26	Micro-USB	MICRO USB 5P/F SMT B	1	
27	U1	IC, ACT2801 T-QFN 44-24	1	ACT

4 PCB LAYOUT

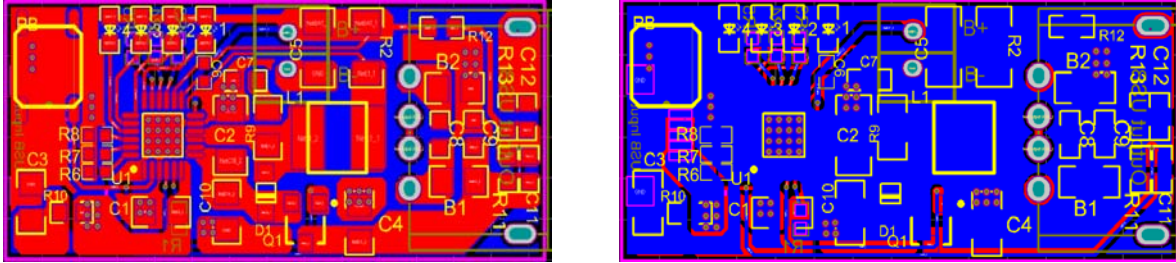

*C1 should be placed close to VIN and PGND; C2 must be placed across VOUT and PGND pins

5 FUNCTIONAL TEST

5.1 Battery Charge V/I profile

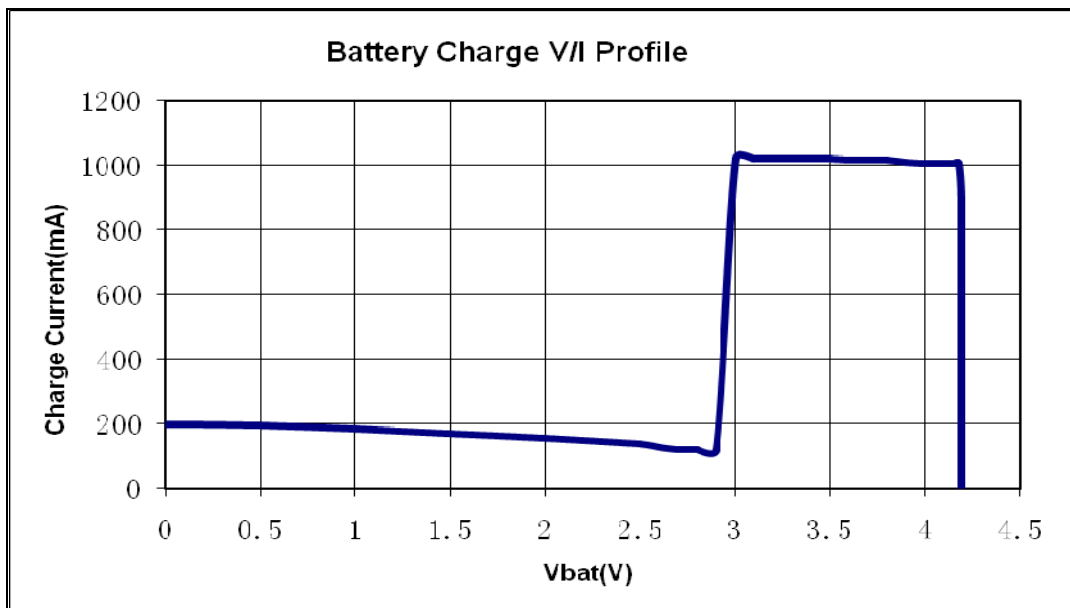

5.2 Power Path Function

Input current(mA)	792	895	993	1092	1287	1312	1325	1330	1334	1343	1347	1355	1359
Output current(mA)	0	100	200	300	500	600	800	900	1000	1100	1200	1300	1360
Charge current(mA)	1021	1020	1021	1020	1017	923	680	551	430	312	194	78	0

(Test condition: Vin=5V, Vbat=3.5V, input current limit=1.5A, fast charge current=1.0A)

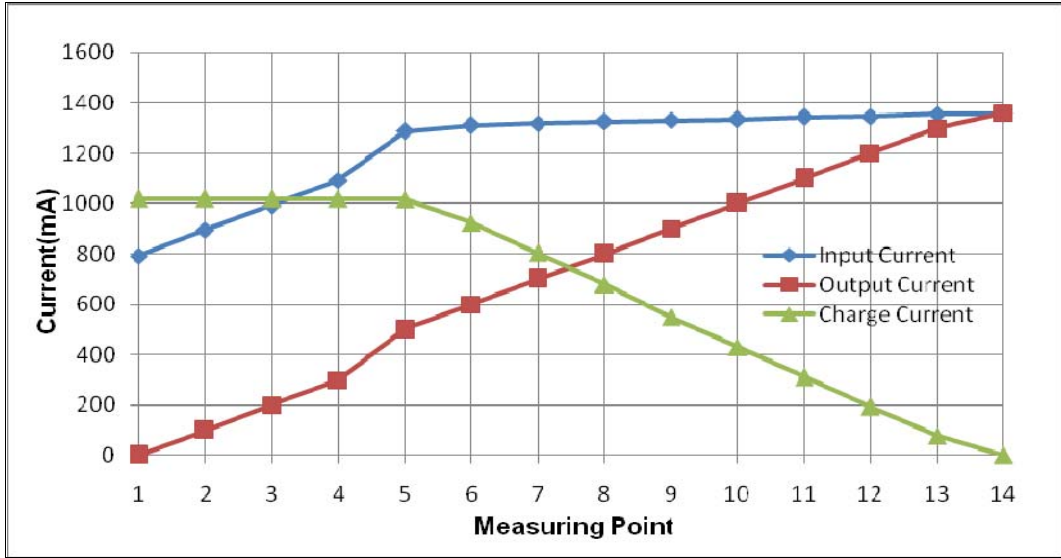

5.3 Charge Efficiency

($V_{in}=5V$ and charge current set at 1000mA)

Battery voltage (V)	3.0	3.5	3.8	4.1
Efficiency (%)	89.6	91.3	92.0	92.2

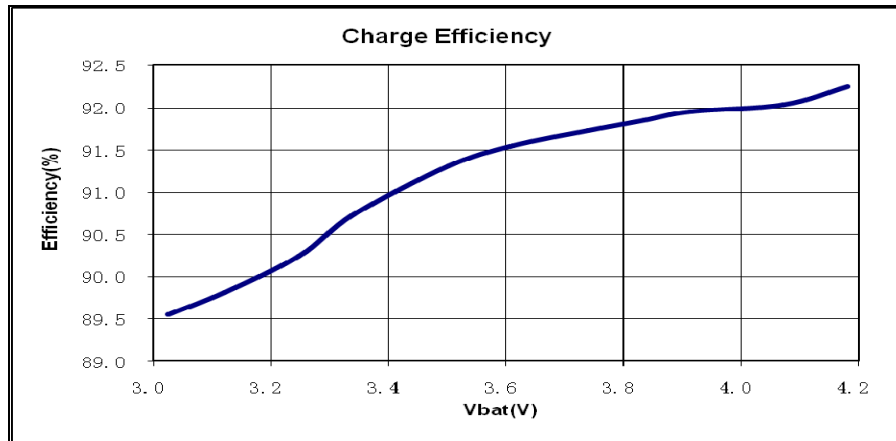

5.4 Boost Output Regulation (Measured at USB port)

Battery Voltage (V)	Output Voltage at 1A Output (V)	Output Voltage at No Load (V)	Load Regulation (%)
3.2	4.955	5.008	1.06
3.7	4.95	5.016	1.31
4.2	4.946	5.028	1.63

5.5 Boost Efficiency and Power Loss (Ta=25°C)

Vbat	Efficiency (%)				
	Io=100mA	Io=200mA	Io=500mA	Io=800mA	Io=1000mA
3.2V	94.1	93.7	94.2	92.5	90.5
3.7V	95.3	94.8	95.5	94.0	92.7
4.2V	96.5	95.8	96.6	95.4	94.3

(Note: bigger inductor size can improve efficiency further)

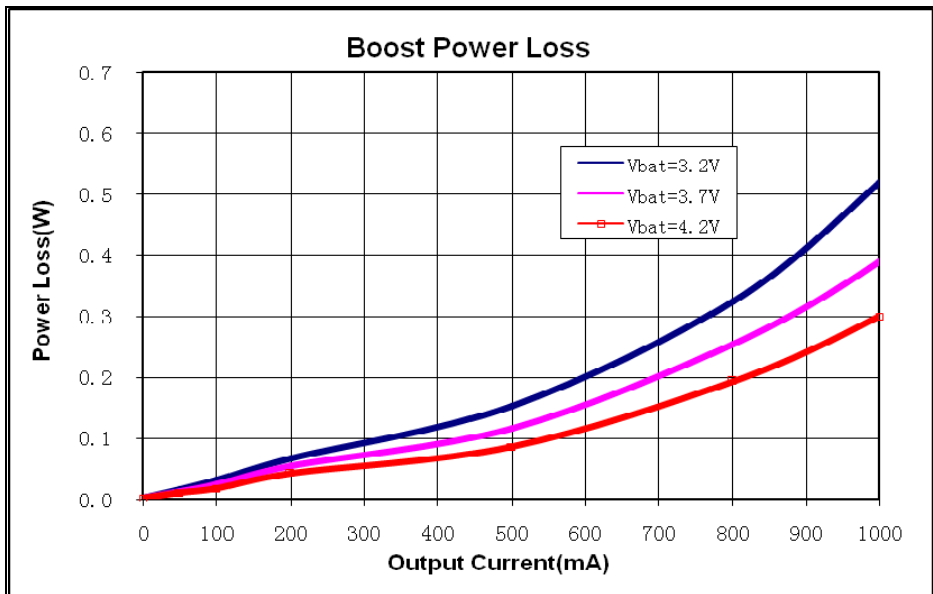
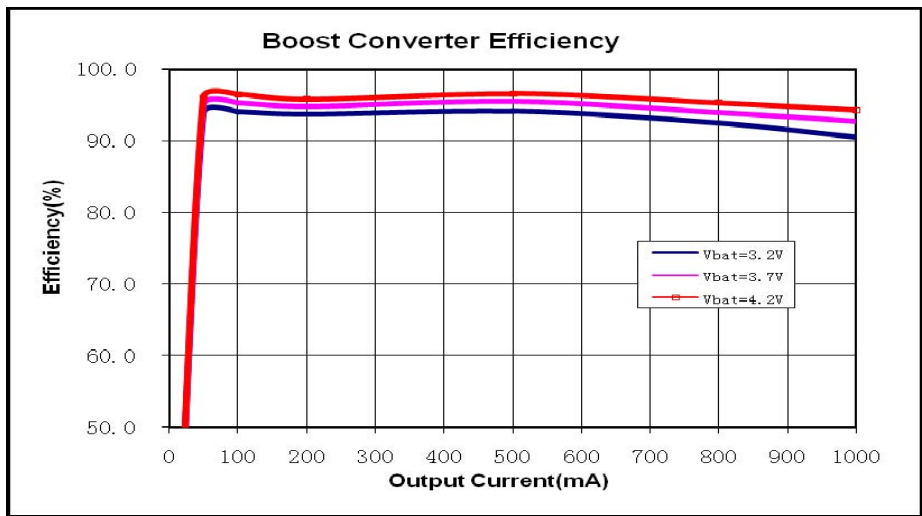

5.6 Boost Standby Power (Ta=25°C)

Battery Voltage(V)	3.2	3.7	4.2
Boost Standby Current(mA)	0.54	0.52	0.52
Boost Standby Power(mW)	1.73	1.92	2.18

5.7 Boost Constant Current and Constant Voltage Regulation (Ta=25°C)

	Vbat=3.2V		Vbat=3.7V		Vbat=4.2V	
	Vout(V)	Iout(mA)	Vout (V)	Iout(mA)	Vout(V)	Iout(mA)
CC Load	5.008	0	5.017	0	5.024	0
	5.004	100	4.944	100	4.999	100
	4.988	200	4.987	200	4.997	200
	4.975	500	4.972	500	4.96	500
	4.95	1000	4.95	1000	4.946	1000
	4.944	1200	4.936	1200	4.932	1200
	4.937	1300	4.929	1300	4.924	1300
CV Load	4.9	1363	4.9	1381	4.9	1376
	4.85	1357	4.85	1376	4.85	1375
	4.8	1358	4.8	1373	4.8	1375
	4.75	1357	4.75	1372	4.75	1375
	4.7	1357	4.7	1370	4.7	1375
	4.65	1356	4.65	1368	4.65	1376
	4.6	1356	4.6	1369	4.6	1376
	4.55	1355	4.55	1368	4.55	1376
	4.5	1356	4.5	1368	4.5	1376
	4.35	1357	4.35	1368	4.35	1378
	4.3	1357	4.3	1369	4.3	1378
	4..25	1358	4..25	1369	4..25	1379
	4.2	1358	4.2	1369	4.2	1380
4.15	1359	4.15	370	4.15	1380	
4.1	0	4.1	0	4.1	0	

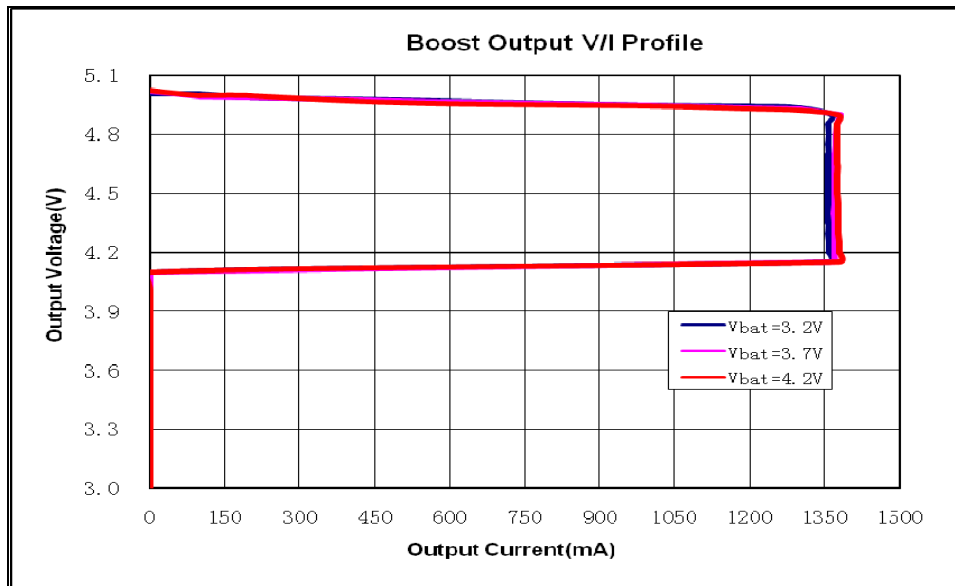

5.8 Battery Leakage Current in HZ Mode

Test Conditions	Battery Input Current (μA)	Power Loss (μW)
V _{bat} =2.8V	5.1	14.3
V _{bat} =3.2V	5.8	18.6
V _{bat} =3.7V	6.4	23.7
V _{bat} =4.2V	7.2	30.2

5.9 Ripple and Noise

Ripple & noise are measured by using 20MHz bandwidth limited oscilloscope.

Test Conditions	Output Ripple at 0.5A Load (mV)	Output Ripple at 1A Load (mV)
V _{bat} =3.2V	18.0	25.2
V _{bat} =3.7V	18.4	25.2
V _{bat} =4.2V	18.5	24.9

5.10 Load Dynamic Response Load Step (80mA-1000mA-80mA load step)

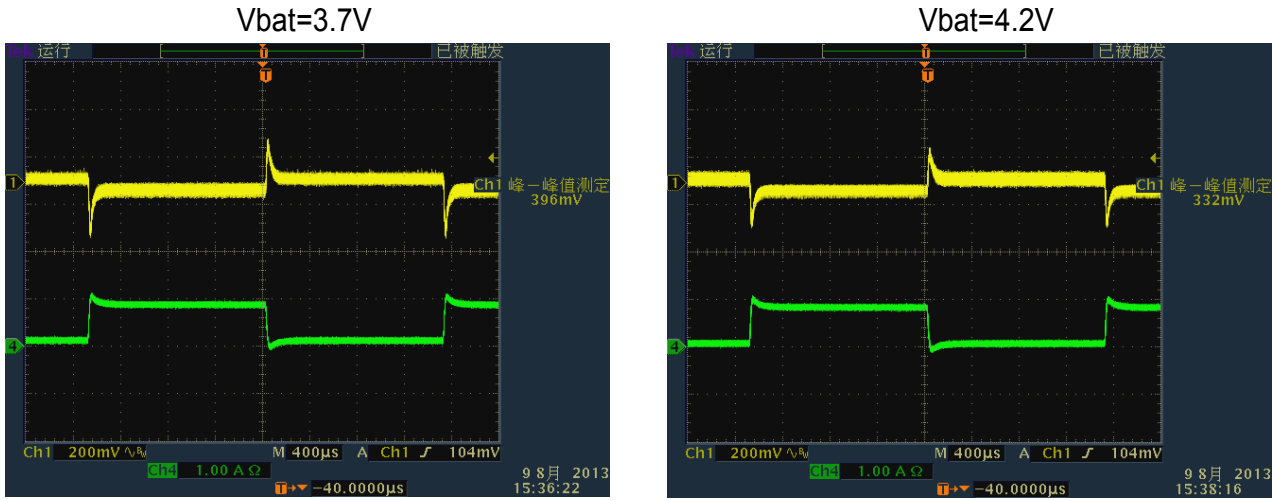

5.11 LED Indication

PB time>100ms (HZ Mode)	LED1	LED2	LED3	LED4
VBAT<3.32V	Off	Off	Off	Off
3.32V≤VBAT<3.66V	On	Off	Off	Off
3.66V≤VBAT<3.81V	On	On	Off	Off
3.81V≤VBAT<4.06V	On	On	On	Off
VBAT≥4.06V	On	On	On	On

Charge Mode	LED1	LED2	LED3	LED4
VBAT<3.58V	Flash	Off	Off	Off
3.58V≤VBAT<3.82V	On	Flash	Off	Off
3.82V≤VBAT<3.96V	On	On	Flash	Off
3.96V≤VBAT<4.06V	On	On	On	Flash
VBAT≥4.06V	On	On	On	Flash
VBAT=4.155V (End of Charge)	On	On	On	On

5.12 System Management

ACT2801 System Operation Flow Chart

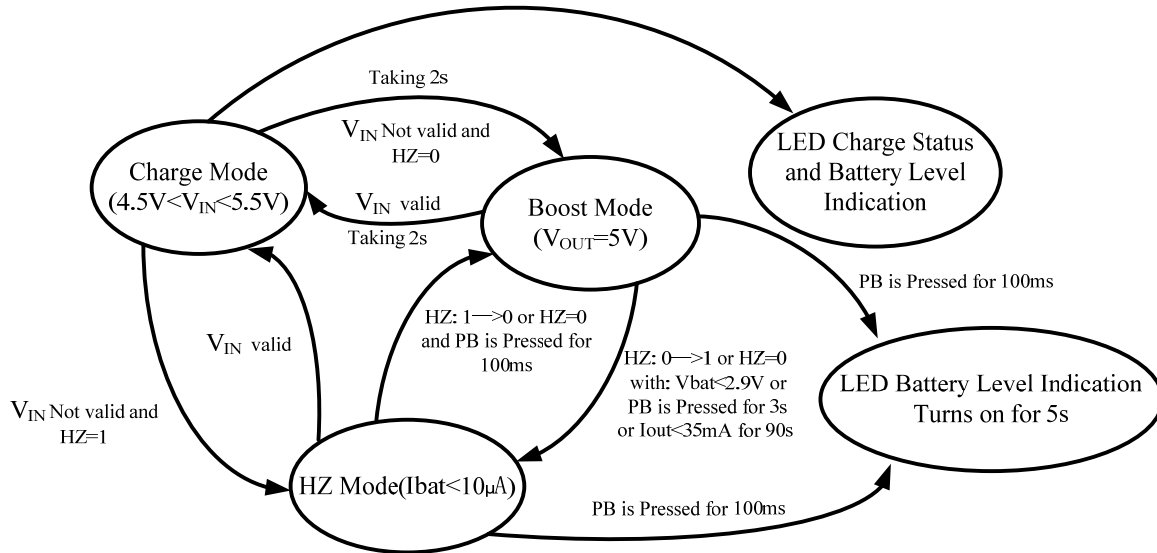

5.13 Key Components Temperature Test (Ta=40°C, burning for 2 hours)

Charge mode, 1.0A charge current

Vin(V)	IC(°C)	Inductor(°C)	PCB(°C)	Vbat(V)
5.0	67.4	62.3	58.8	3.2
5.0	65.6	60.6	57.3	3.7
5.0	63.7	59.3	56.0	4.2

Boost mode, 1.2A output current

Vbat(V)	IC(°C)	Inductor(°C)	PCB(°C)	Vout(V)
3.2	80.4	84.2	72.9	5.0
3.7	70.0	72.4	65.2	5.0
4.2	63.3	64.9	60.1	5.0

6 PCB LAYOUT GUIDANCE

The following guideline is base on the schematic in Section 2.

- 1) Arrange the power components to reduce the AC loop size that consists of C2, VOUT, SW and PGND. C2 (1206 size) must be placed close to the IC and across the VOUT and PGND traces and SW trace goes under the C2 as shown in the following layout figure.
- 2) Use copper plane for PGND for best heat dissipation and noise immunity. AGND and PGND are connected under the IC thermal pad with 4x4 vias matrix.
- 3) SW copper area should be limited due to EMI consideration.
- 4) Use Kevin sense from sense resistor R2 to CSP and CSN pins as shown in the layout figure.
- 5) A separate trace is from VBAT input to BAT pin for battery voltage sense accuracy.
- 6) RC snubber is recommended to add across SW to PGND to reduce EMI noise.
- 7) A 10V/1A schottky is added from inductor terminal to VOUT to reduce EMI noise.

Top Layer

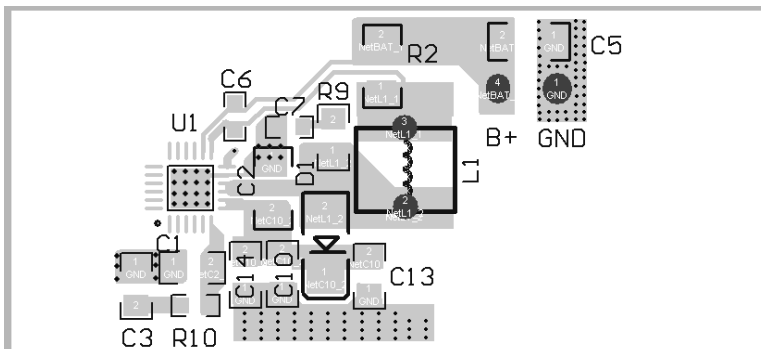

Bottom Layer

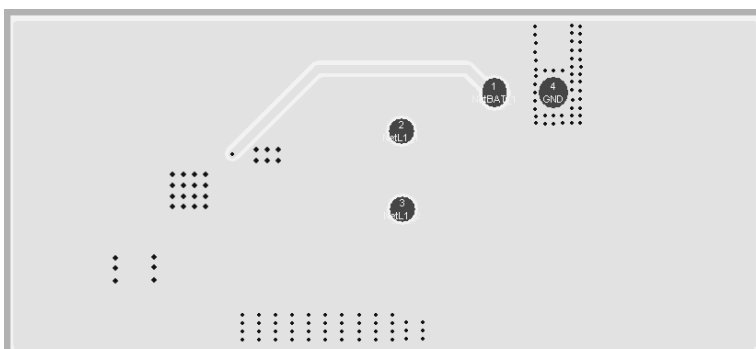

7 EMI TEST

Vbat=4.1V, Output : 5V/1A Horizontal

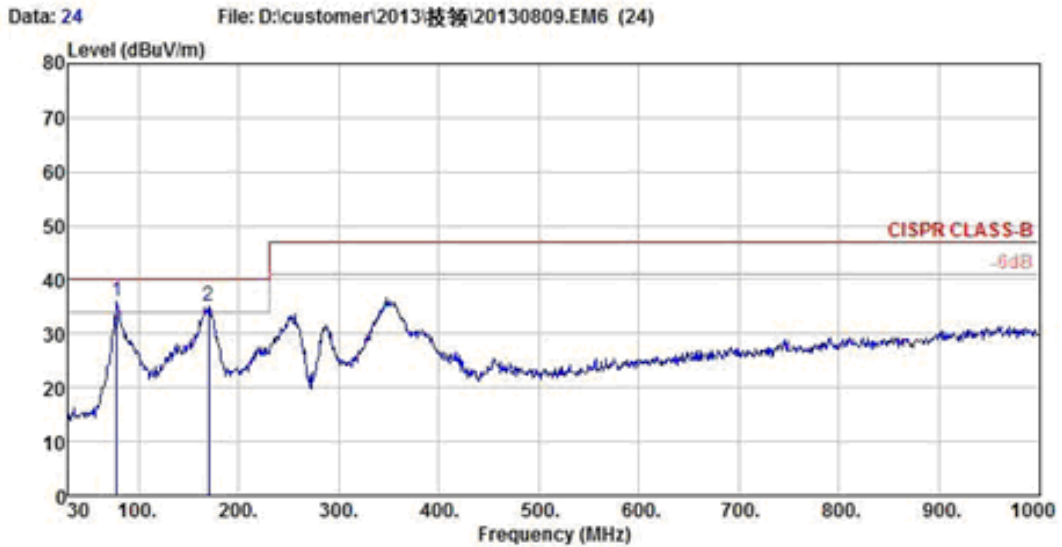

Site : chamber
 Condition : CISPR CLASS-B 3m VULB9160 HORIZONTAL
 EUT :
 Model Name : ACT2801 BOOST LOAD 1A VBAT=4.1V
 Temp/Humi : 24 °C /58%
 Power Rating: dc
 Mode :
 Memo :
 : #2

	Freq	ReadAntenna Level	Antenna Factor	Cable Loss	Preamp Factor	Level	Limit Line	Over Limit	Remark
	MHz	dBuV	dB/m	dB	dB	dBuV/m	dBuV/m	dB	
1	pp	78.50	25.87	9.14	1.09	0.00	36.10	40.00	-3.90 Peak
2	!	169.68	20.04	13.33	1.84	0.00	35.21	40.00	-4.79 Peak

Vbat=4.1V, Output : 5V/1A Vertical

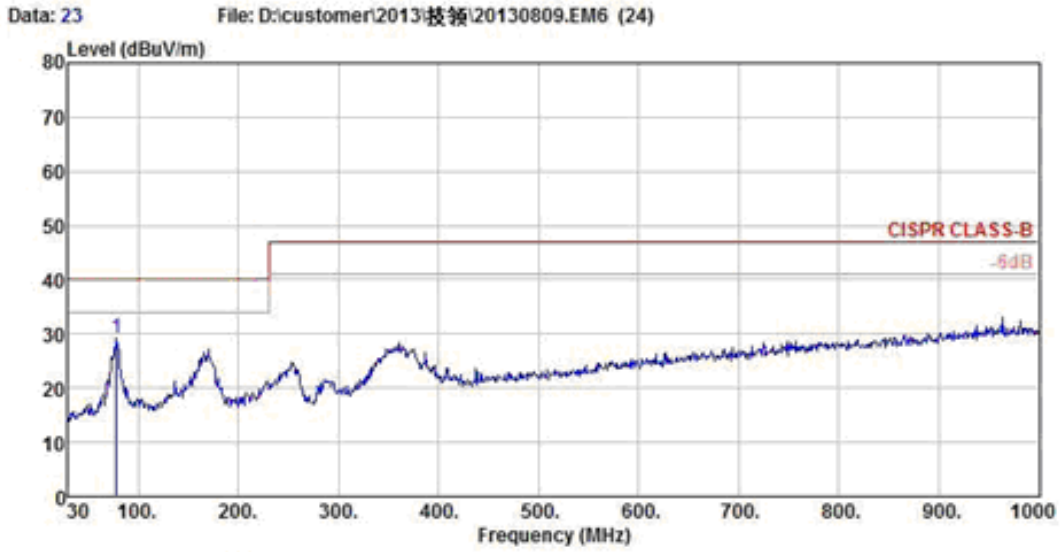

```

Site       : chamber
Condition  : CISPR CLASS-B 3m VULB9160 VERTICAL
EUT       :
Model Name : ACT2801 BOOST LOAD 1A VBAT=4.1V
Temp/Humi  : 24 °C /58%
Power Rating: dc
Mode       :
Memo       :
           : #2
    
```

	Read	Antenna	Cable	Preamp	Limit	Over	
Freq	Level	Factor	Loss	Factor	Level	Line	Limit Remark
MHz	dBuV	dB/m	dB	dB	dBuV/m	dBuV/m	dB
1 pp	78.50	18.90	9.14	1.09	0.00	29.13	40.00 -10.87 Peak