

## High Efficiency, Constant Current 36V, 1A LED Driver with Internal Switch

### Feature

- Operating Voltage: 7V to 36V
- Output driving current up to 1A (1 × LED)
- Internal PWM filter
- Shutdown Current <math><20\mu\text{A}</math> (Typ)
- Digital Dimming Control
- Thermal Overload Protection
- Open/Shorted LED Protection
- SOP-8, SOT-23-5 and SOT-89-5 Package

### Description

The G2620 is a step-down converter, designed for driving high-brightness LED. The device operates over a 7V to 36V input voltage and driving current from few milliamps up to 1A.

The device built-in Overload Protection to prevent operating fails condition.

### Application

- GPS Navigation System
- Compact Back Light Module
- Constant Current Source
- LED Module

### Ordering Information

ORDER NUMBER	MARKING	TEMP. RANGE	PACKAGE (Green)
G2620P11U	G2620	-40°C to +105°C	SOP-8
G2620T11U	2620x	-40°C to +105°C	SOT-23-5
G2620TE1U	2620	-40°C to +105°C	SOT-89-5

Note: P1: SOP-8    T1: SOT23-5    TE: SOT-89-5  
 1: Bonding Code  
 U: Tape & Reel

### Pin Configuration

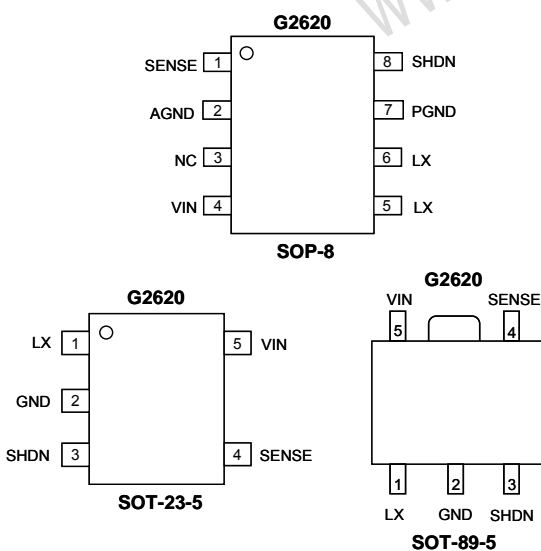

### Typical Application Circuit

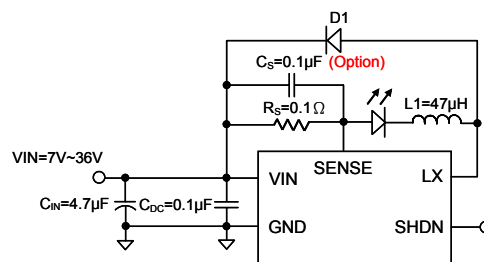

\*The PCB layout of G2610 must be carefully designed, otherwise the SENSE pin would be disturbed. An optional 0.1μF decoupling capacitor(C<sub>S</sub>) between VIN and SENSE is suggested, please place it as closely to VIN and SENSE as possible.

## Absolute Maximum Ratings\*1

LX to GND	.....-0.3V to +40V (42V for 0.5sec)
VIN to GND	.....-0.3V to +40V (42V for 0.5sec)
SENSE to GND	.....-0.3V to +40V (42V for 0.5sec)
SHDN to GND	.....-0.3V to +6V
Switch Current (I <sub>LX</sub> )	.....1.5A
Thermal Resistance Junction to Ambient, (θ <sub>JA</sub> )*	
SOP-8	.....160°C/W
SOT-23-5	.....250°C/W
SOT-89-5	.....135°C/W
Continuous Power Dissipation (T <sub>A</sub> = +25°C)*	
SOP-8	.....0.78W
SOT-23-5	.....0.5W
SOT-89-5	.....0.92W

Thermal Resistance Junction to Case, (θ <sub>JC</sub> )	
SOP-8	.....39°C/W
SOT-23-5	.....60°C/W
SOT-89-5	.....14°C/W
Operating Temperature Range	.....-30°C to +105°C
Junction Temperature	.....150°C
Storage Temperature Range	.....-65°C to +125°C
Reflow Temperature (soldering, 10sec)	.....260°C
ESD Susceptibility*2	
HBM	.....2kV
MM	.....200V

\* Please refer to "Minimum Footprint PCB Layout Section".

1. Stresses beyond those listed under "Absolute Maximum Ratings" may cause permanent damage to the device. These are stress ratings only, and functional operation of the device at these or any other conditions beyond those indicated in the operational sections of the specifications is not implied. Exposure to absolute maximum rating conditions for extended periods may affect device reliability.
2. Device are ESD sensitive. Handling precaution recommended. The Human Body model is a 100pF capacitor discharged through a 1.5kΩ resistor into each pin.
3. Depending on PC board layout.

## Electrical Characteristics

(V<sub>IN</sub>=12V, L=47μH, 1\*LED, LED Current=330mA, T<sub>A</sub>=+25°C.)

The device is not guaranteed to function outside its operating conditions. Parameters with MIN and/or MAX limits are 100% tested at +25°C, unless otherwise specified.

Parameter	Symbol	Condition	Min.	Typ.	Max.	Unit
Input Voltage	V <sub>IN</sub>		7	---	36	V
Under Voltage Threshold	V <sub>SU</sub>	V <sub>IN</sub> rising.	---	6.0	---	V
	V <sub>SD</sub>	V <sub>IN</sub> falling.	---	5.55	---	V
Quiescent supply current with output off	I <sub>Qoff</sub>	SHDN pin grounded.	---	20	40	μA
Quiescent supply current with output switching	I <sub>Qon</sub>	SHDN pin floating, f=250kHz.	---	1.8	5.0	mA
Mean current sense threshold voltage(Defines LED current setting accuracy)	V <sub>SENSE</sub>	Measured on SENSE pin with respect to V <sub>IN</sub> . L=47μH, I <sub>OUT</sub> =330mA.	97	100	103	mV
Sense threshold hysteresis	V <sub>SENSEHYS</sub>		---	±15	---	%
Maximum LED average current	I <sub>MLED</sub>	L=47μH, NOTE (1)	---	---	1	A
SENSE pin input current	I <sub>SENSE</sub>	V <sub>SENSE</sub> =V <sub>IN</sub> -0.1V	---	5	10	μA
Temperature coefficient of V <sub>REF</sub>	ΔV <sub>REF</sub> /ΔT		---	50	---	ppm/k
LX Switch on resistance	R <sub>LX</sub>	LX switch ON resistance.	---	0.5	1.0	Ω
LX switch leakage current	I <sub>LX(leak)</sub>	LX switch leakage current.	---	1	5	μA
Operating frequency	f <sub>LX</sub>	SHDN floating, L=47μH, I <sub>OUT</sub> =330mA.	---	600	---	kHz
SHDN Input level	Logic High	V <sub>IH</sub>	1.5	---	---	V
	Logic Low	V <sub>IL</sub>	---	---	0.18	V
SHDN low shutdown delay	---		---	10	---	mS
SHDN Input current	I <sub>SD</sub>	V <sub>SHDN</sub> =0V.	---	---	5	μA
Thermal Shutdown	T <sub>sd</sub>		---	150	---	°C
Thermal Shutdown Hysteresis	---		---	30	---	°C

NOTE (1). The power dissipation of the SOT-23-5 must be lower than 0.3W at 70°C. Suggest the number of LEDs should be one only, when LED average current is 1000mA.

**Typical Characteristics**

Condition:  $V_{IN}=12V$ ,  $L=47\mu H$ ,  $C_{IN}=10\mu F$  and  $0.1\mu F$ , 1\*LED, LED Current=1000mA.

**Soft-start**

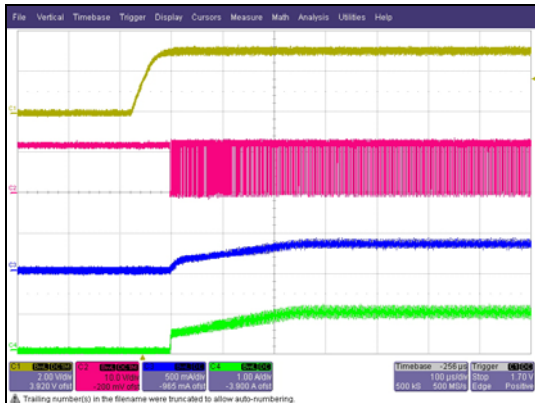

CH1: EN Voltage(2V/div), CH2: LX Voltage(10V/div)  
CH3: Input Current(500mA/div), CH4: LED Current(1A/div)  
(100us/div)

**Power on**

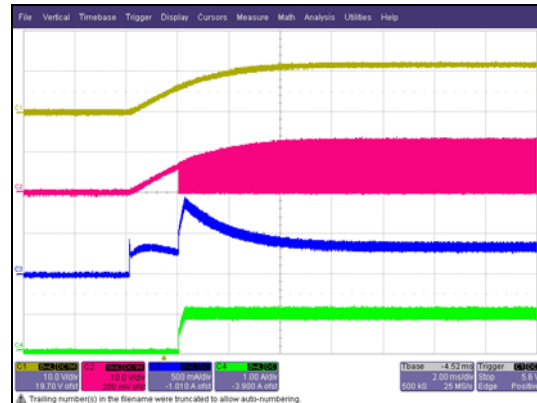

CH1: Input Voltage(10V/div), CH2: LX Voltage(10V/div)  
CH3: Input Current(500mA/div), CH4: LED Current(1A/div)  
(2ms/div)

**Power off**

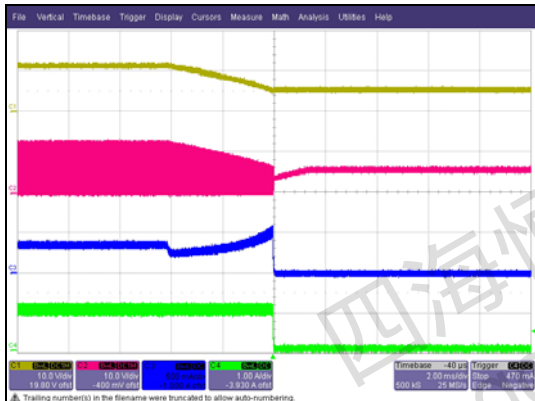

CH1: Input Voltage(10V/div), CH2: LX Voltage(10V/div)  
CH3: Input Current(500mA/div), CH4: LED Current(1A/div)  
(2ms/div)

**LED Current Ripple**

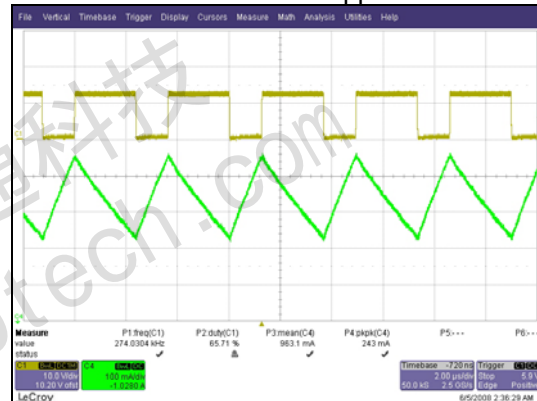

CH1: LX Voltage(10V/div),  
CH4: LED Current(100mA/div)  
(2us/div)

**Input Voltage is Electronic transformer (AC=12V)**

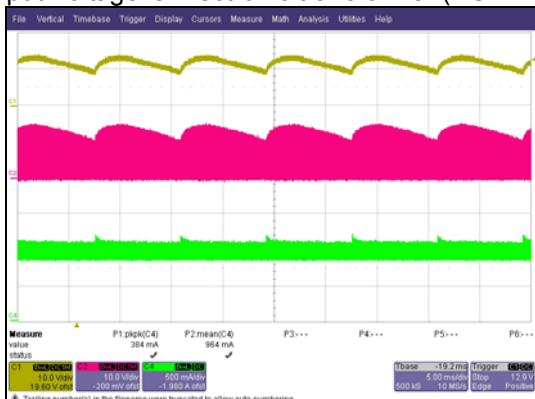

CH1: Input Voltage(10V/div), CH2: LX Voltage(10V/div)  
CH4: LED Current(500mA/div)  
(5ms/div)

**Dimming Control**

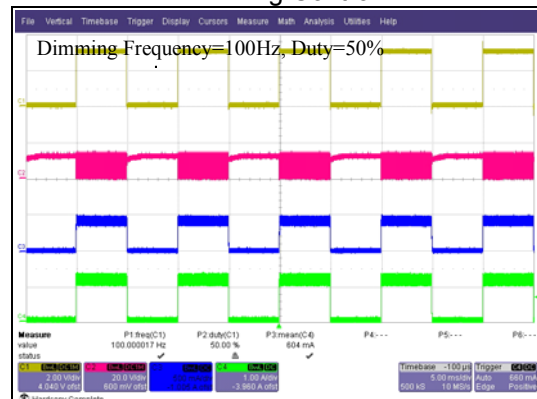

CH1: EN Voltage(2V/div), CH2: LX Voltage(20V/div)  
CH3: Input Current(500mA/div), CH4: LED Current(1A/div)  
(5ms/div)

**Typical Characteristics**

Condition:  $V_{IN}=12V$ ,  $L=47\mu H$ ,  $C_{IN}=10\mu F$  and  $0.1\mu F$ , 1\*LED, LED Current=1000mA.

Vsense vs. Input Voltage

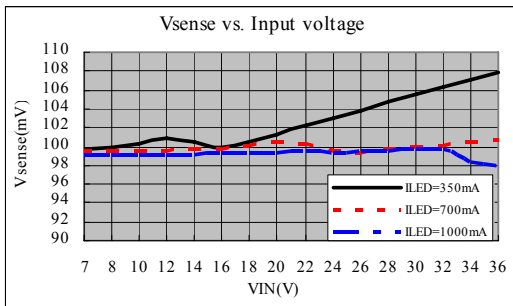

Vsense vs. LED Current

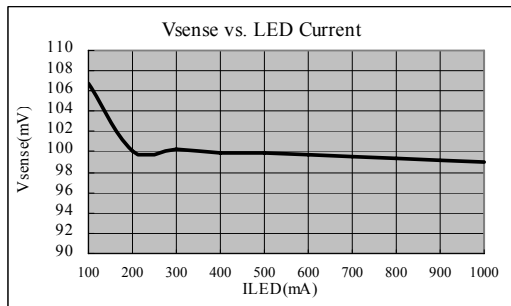

Vsense vs. Temperature

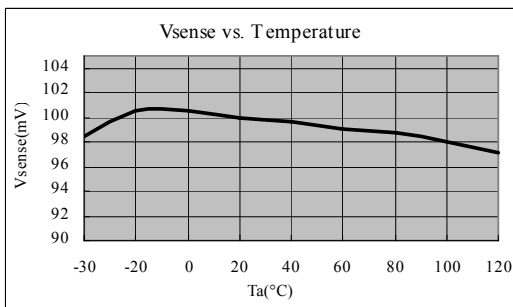

Vsense vs. Inductor

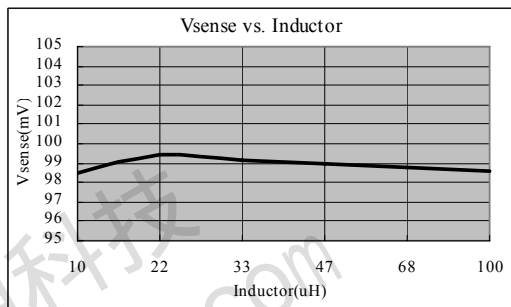

Shutdown Current vs. Input Voltage

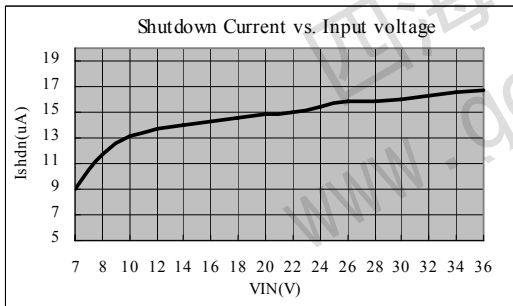

MOSFET Rds(on) vs. LED Current

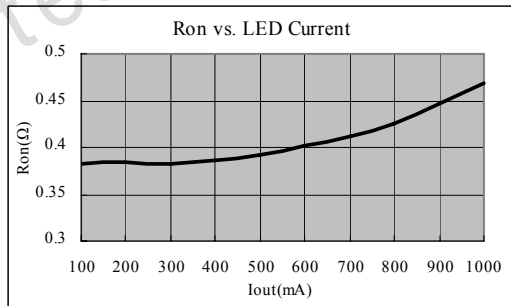

Vsense vs. PWM Dimming

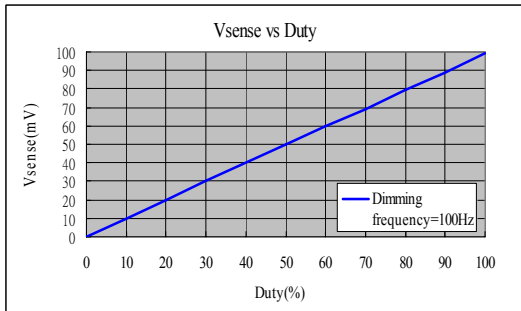

Vsense vs. PWM Dimming

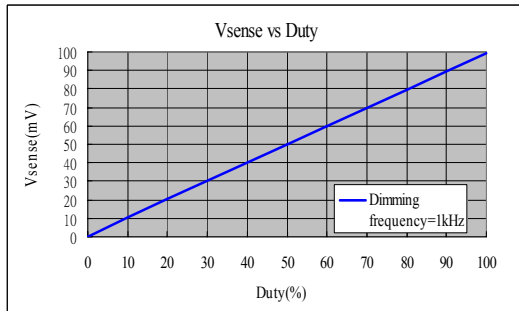

**Typical Characteristics**

Condition:  $V_{IN}=12V$ ,  $L=47\mu H$ ,  $C_{IN}=10\mu F$  and  $0.1\mu F$ , 1\*LED, LED Current=1000mA.

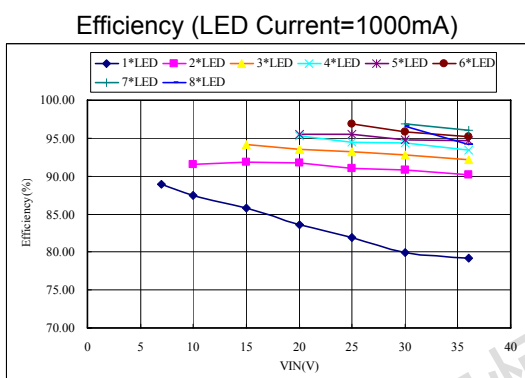
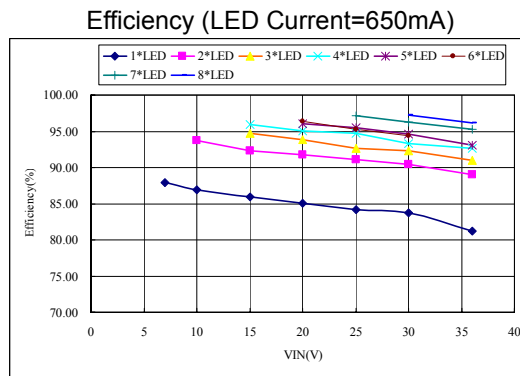
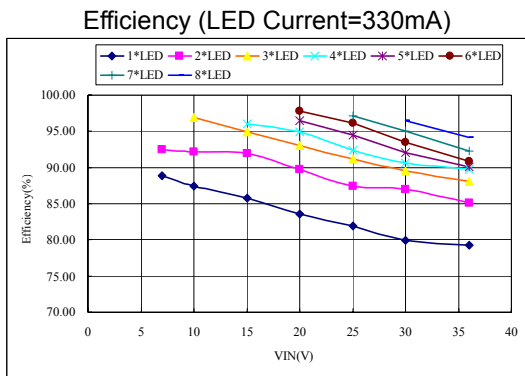

**Minimum Footprint PCB Layout Section**

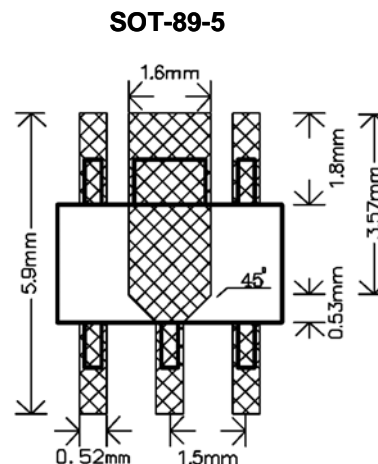
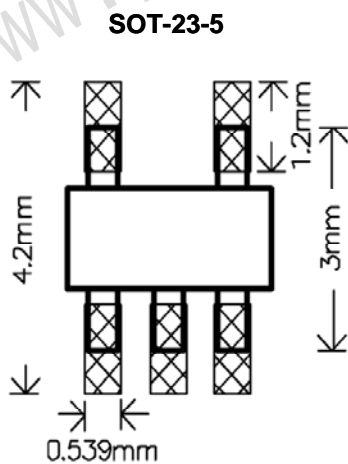
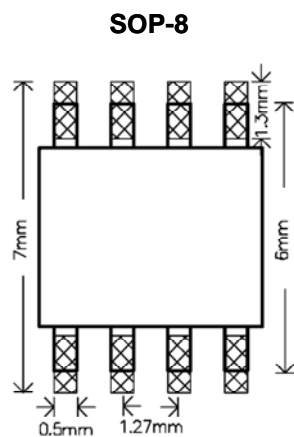

**Pin Description**

PIN Number			Symbol	Descript
SOP-8	SOT-23-5	SOT-89-5		
5,6	1	1	LX	Step-down Regulator N-MOS Drain. Place output diode and inductor.
2,7	2	2	GND, PGND	Ground.
8	3	3	SHDN	Dimming and Shutdown pin. 1. For automatic startup, leave SHDN unconnected. 2. Drive to voltage below 0.5V to turn off LED Current.
1	4	4	SENSE	Connect resistor Rs from this pin to VIN to define nominal average output current.
4	5	5	VIN	Input Voltage.
3			NC	No Connect

**Block Diagram**

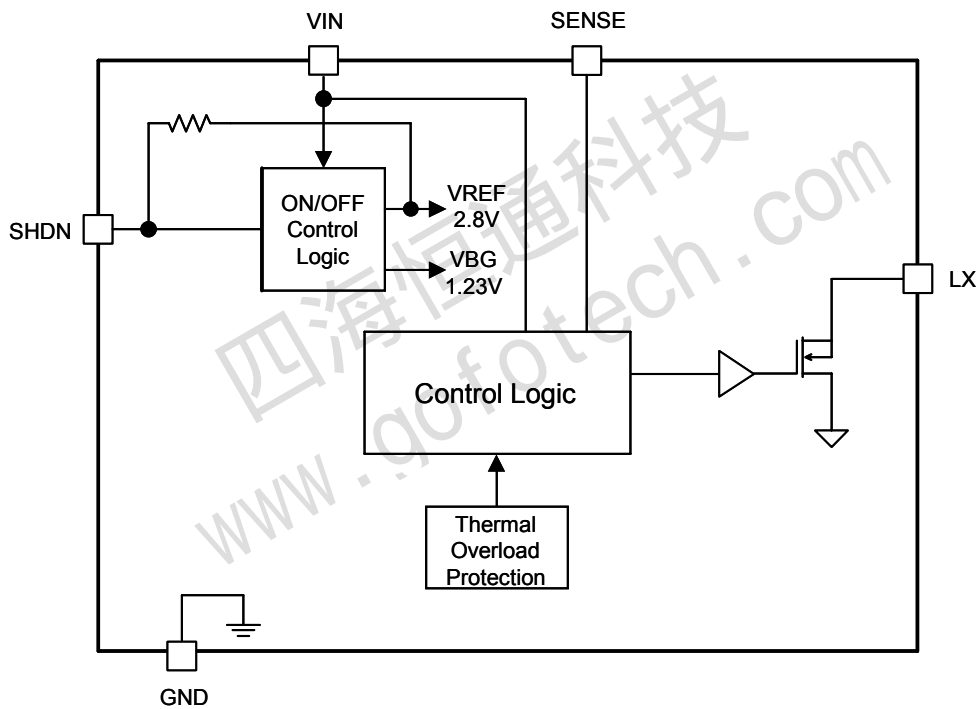

---

**General Description****Shutdown Control**

Digital logic of SHDN provides an electrical ON/OFF control of the power supply. Connecting this pin to ground or to any voltage less than 0.6V and sustain the level over 10ms will completely turn off the regulator. In this state, current drain from the input supply is less than 20 $\mu$ A (Typ.), the internal reference, error amplifier, comparators, and biasing circuitry turn off. If holding time of low level is less than 10ms on this pin, then the device only shutdown driver logic block.

**Dimming Control**

Digital logic of SHDN also provides LEDs brightness control by applying a PWM signal on SHND pin. With this way, the LEDs operate with either zero or full current. The average LED current is proportional to the duty-cycle of the PWM signal. Typical PWM frequency should be between 100Hz to 1kHz.

If dimming control is not required, SHDN works as a simple on/off control.

**Thermal Shutdown**

Thermal-overload protection limits total power dissipation in the G2620. When the junction temperature exceeds  $T_j=150^{\circ}\text{C}$ , a thermal sensor activates the thermal protection, which shutdowns the IC, allowing the IC to cool. Once the device cools down by  $30^{\circ}\text{C}$ , IC will automatically recover normal operation.

四海恒通科技  
www.gofotech.com

## Application Information

### Programming average LED current

The sense resistor ( $R_s$ ) and the sense voltage ( $V_{IN}$ - $V_{sense}$ ) control the LED average current.

$$I_{LED} = \frac{0.1}{R_s}$$

LED Current (mA)	$R_s(\Omega)$
350mA	0.285
700mA	0.142
1000mA	0.1

In order to have accurate LED current, precision resistors are preferred (1% is recommend).

### Operating Frequency

$$f_s = \frac{1}{T_{ON} + T_{OFF}}$$

Where:

$f_s$  is operating frequency

$T_{ON}$  is LX on time

$T_{OFF}$  is LX off time

LX on time

$$T_{ON} = \frac{L\Delta I_L}{V_{IN} - V_{LED} - I_{LED}(R_s + r_L + R_{LX(ON)})}$$

$T_{ONmin} > 250ns$

LX off time

$$T_{OFF} = \frac{L\Delta I_L}{V_{LED} + V_D + I_{LED}(R_s + r_L)}$$

$T_{OFFmin} > 250ns$

Where:

$V_{IN}$  is the Input Voltage

$V_{LED}$  is the total LED forward voltage

$I_{LED}$  is the LED average current

$R_s$  is the current sense resistance

$r_L$  is the inductor resistance

$R_{LX(ON)}$  is the LX on resistance (0.5 $\Omega$  typ.)

$L$  is the inductance

$\Delta I_L$  is the inductor peak-peak current (internally set to  $I_{avg} \times 0.3$ )

$V_D$  is the diode forward voltage at the LED average Current

Recommend operating frequency not more than 1MHz.



## Power Dissipation Calculation

Power dissipation of the G2620 comes from four sources: N-MOSFET power dissipation, Diode dissipation, Input quiescent current, and Rs dissipation.

The power dissipation of high side N-MOSFET:

$$P_{N-MOSFET} = I_{RMS}^2 \times R_{DS(on)-N} + \frac{1}{2} \times (V_{IN} + V_D) \times (I_{L(peak)} \times t_r + I_{L(Low)} \times t_f) \times f_s$$

$R_{DS(on)-N}$  is resistance of the N-MOSFET.

$I_{L(peak)}$  is peak value of the inductor current.

$I_{L(low)}$  is low value of inductor current.

$f_s$  is the switching frequency.

$t_r$  is the switching rise time, typically <20ns.

$t_f$  is the switching fall time, typically <20ns.

The RMS value of the N-MOSFET:

$$I_{RMS} = \sqrt{\frac{(I_{L(peak)}^2 + I_{L(peak)} \times I_{L(low)} + I_{L(low)}^2) \times D}{3}}$$

$$\Delta I_L = \frac{V_{IN} - V_{sense} - V_{LED}}{L} DT_s$$

$$I_{L(peak)} = I_{LED} + \frac{1}{2} \Delta I_L$$

$$I_{L(low)} = I_{LED} - \frac{1}{2} \Delta I_L$$

Quiescent current dissipation:

$$P_Q = V_{IN} \times I_Q = V_{IN} \times [I_{Qon} \times D + I_{Qoff} (1 - D)]$$

G2620 inside dissipation:

$$P_{IC} = P_{N-MOSFET} + P_Q$$

Diode dissipation, and Rs dissipation:

$$P_L = I_{LED} \times V_D \times (1 - D) + I_{LED}^2 \times R_s$$

Power total dissipation:

$$P_t = P_{IC} + P_L$$

D is duty cycles.

$I_Q$  is the quiescent current.

### Example

$V_{IN}=12V$ ,  $L=47\mu H$ ,  $f_s=600kHz$ ,  $Duty=30\%$ ,  $R_s=0.28\Omega$ ,  $R_{DS(ON)}=0.5\Omega$ ,  $V_D=0.4V$ ,  $V_{SENSE}=0.1V$ ,  $V_{LED}=3.2V$ ,  $I_{LED}=350mA$ ,  $I_{Qon}=1.8mA$ ,  $I_{Qoff}=20\mu A$ ,  $t_r=20ns$ ,  $t_f=15ns$

$$I_{L(peak)} = I_{LED} + \frac{\Delta I_L}{2} = 0.35 + \frac{12 - 0.1 - 3.2}{2 \times 47 \times 10^{-6}} \times 0.3 \times \frac{1}{600 \times 10^3} = 396.28mA$$

$$I_{L(low)} = I_{LED} - \frac{\Delta I_L}{2} = 303.72mA$$

$$I_{RMS} = \sqrt{\frac{(396.28^2 + 396.28 \times 303.72 + 303.72^2) \times 0.3}{3}} = 192.26mA$$

$$P_{N-MOSFET} = 0.19226^2 \times 0.5 + \frac{1}{2}(12 + 0.4) \times (0.39628 \times 20 \times 10^{-9} + 0.30372 \times 15 \times 10^{-9}) \times 600 \times 10^3 = 0.065W$$

$$P_Q = 12 \times [1.8 \times 10^{-3} \times 0.3 + 20 \times 10^{-6}(1 - 0.3)] = 6.65mW$$

$$P_{IC} = 0.065 + 0.00665 = 0.07165W$$

$$P_L = 0.35 \times 0.4 \times (1 - 0.3) + 0.35^2 \times 0.28 = 0.1323W$$

$$P_t = 0.07165 + 0.1323 = 0.20395W$$

### Diode Selection

When the LX switch turns off, the current through the inductor continues to flow. The path for this current is through the diode connected between the LX switch and VIN. This forward biased diode must have a minimum voltage drop and recovery times. Schottky diode is recommended and it should be able to handle those current. As usual, the reverse voltage rating of the diode should be at least 1.3 times greater than the maximum input voltage, and current rating is greater than the maximum load current.

### Diode Open

If the diode (D1) is open circuit, the energy stored in the inductor will drive LX voltage higher. The chip will be damaged if LX voltage higher than 40V. The diode can not be opened in use.

### Input Capacitor

An input capacitor ( $C_{IN}$ ) helps to provide additional current to the power supply as well as smooth input voltage variations in high current switching regulators. When selecting an input capacitor, a low ESR capacitor is required to keep the noise at the IC to a minimum. Ceramic capacitors are preferred, but tantalum or low-ESR electrolytic capacitors may also suffice. Choose an input capacitor with maximum voltage rating is 1.3 times greater than the maximum input voltage, and RMS current rating is equal to one-half of the maximum dc load current. It may be necessary in some designs to add a small valued ceramic type capacitor in parallel with the input capacitor to prevent any ring.

**Decoupling Capacitor**

This is the decoupling capacitor (CDC) for the input voltage to the internal circuit. Use a 0.1 $\mu$ F capacitor and place it as closely to the VIN and GND pins as possible.

**Inductor Selection**

Recommended inductor (L1) values for the G2620 are in the range 22 $\mu$ H to 100 $\mu$ H.

Once an inductance value is determined from the frequency equation, the maximum operating current must be verified. Although peak-to-peak ripple current is controlled by the hysteresis value, there is some variation due to propagation delay. This means that the inductance has a direct effect on LED current line regulation. In general, a larger inductor will result in lower frequency and better line regulation.

**PC Board Layout**

1. The most critical aspect of the layout is the placement of the decoupling capacitor ( $C_{DC}$ ) and input capacitor ( $C_{IN}$ ). It must be placed as close as possible to the G2620 to reduce the input ripple voltage.
2. Power loops on the input and output of the converter should be laid out with the shortest and widest traces possible. The longer and narrower the trace, the higher resistance and inductance it will have. The length of traces in series with the capacitors increases its ESR and ESL and reduces their effectiveness at high frequency.
3. The SENSE pin should connect to sense resistors directly. And the route should be away from the noise source, such as inductor of LX line. Sense resistors must be placed as close as to the sense pin.

四海恒通科技  
www.gofotech.com

**Package Information**

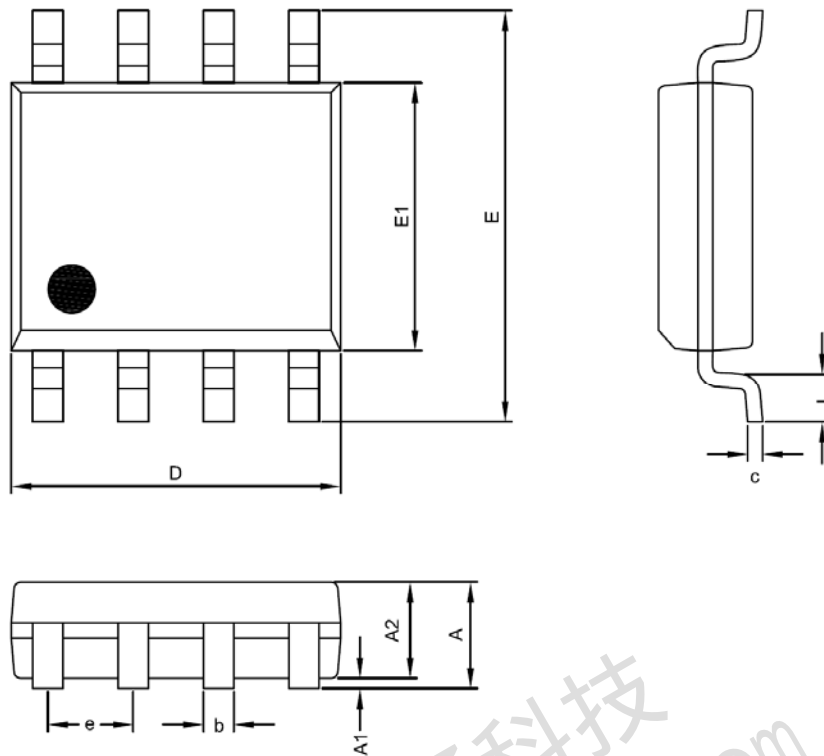

**SOP-8 (P1) Package**

Symble	DIMENSION IN MM			DIMENSION IN INCH		
	MIN.	NOM.	MAX.	MIN.	NOM.	MAX.
A	1.35	1.55	1.75	0.053	0.061	0.069
A1	0.00	---	0.25	0.000	---	0.010
A2	1.15	1.35	1.50	0.045	0.053	0.059
D	4.80	4.90	5.00	0.189	0.192	0.197
E	5.80	6.00	6.20	0.228	0.236	0.244
E1	3.80	3.90	4.00	0.150	0.153	0.157
c	0.19	0.23	0.27	0.007	0.009	0.011
b	0.33	0.43	0.53	0.013	0.017	0.021
e	1.27 BSC			0.050 BSC		
L	0.40	0.7	1.00	0.016	0.028	0.039

**Taping Specification**

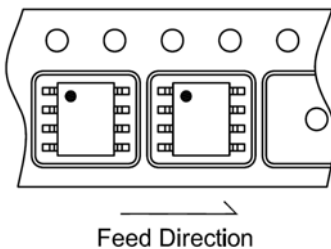

PACKAGE	Q'TY/REEL
SOP-8	2,500 ea

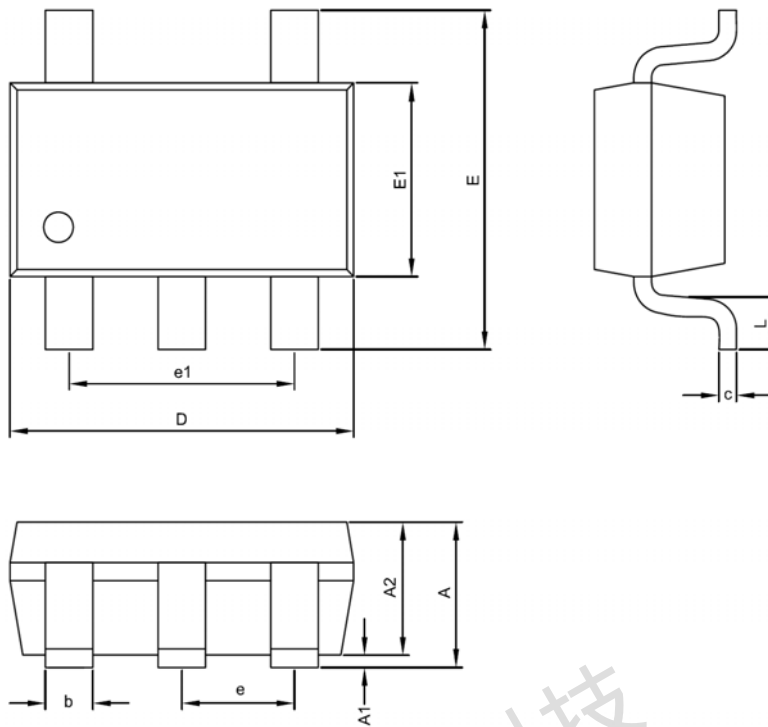

SOT-23-5 Package

Symble	DIMENSION IN MM			DIMENSION IN INCH		
	MIN.	NOM.	MAX.	MIN.	NOM.	MAX.
A	1.00	1.10	1.45	0.039	0.043	0.057
A1	0.00	---	0.10	0.000	---	0.004
A2	1.00	1.10	1.30	0.039	0.043	0.051
D	2.70	2.90	3.10	0.106	0.114	0.122
E	2.60	2.80	3.00	0.102	0.110	0.118
E1	1.50	1.60	1.70	0.059	0.063	0.067
c	0.08	0.15	0.25	0.003	0.006	0.010
b	0.30	0.40	0.50	0.012	0.016	0.020
e	0.95 BSC			0.037 BSC		
e1	1.90 BSC			0.075 BSC		
L	0.30	0.45	0.60	0.012	0.018	0.024

**Taping Specification**

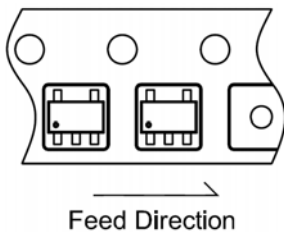

PACKAGE	Q'TY/REEL
SOT-23-5	3,000 ea

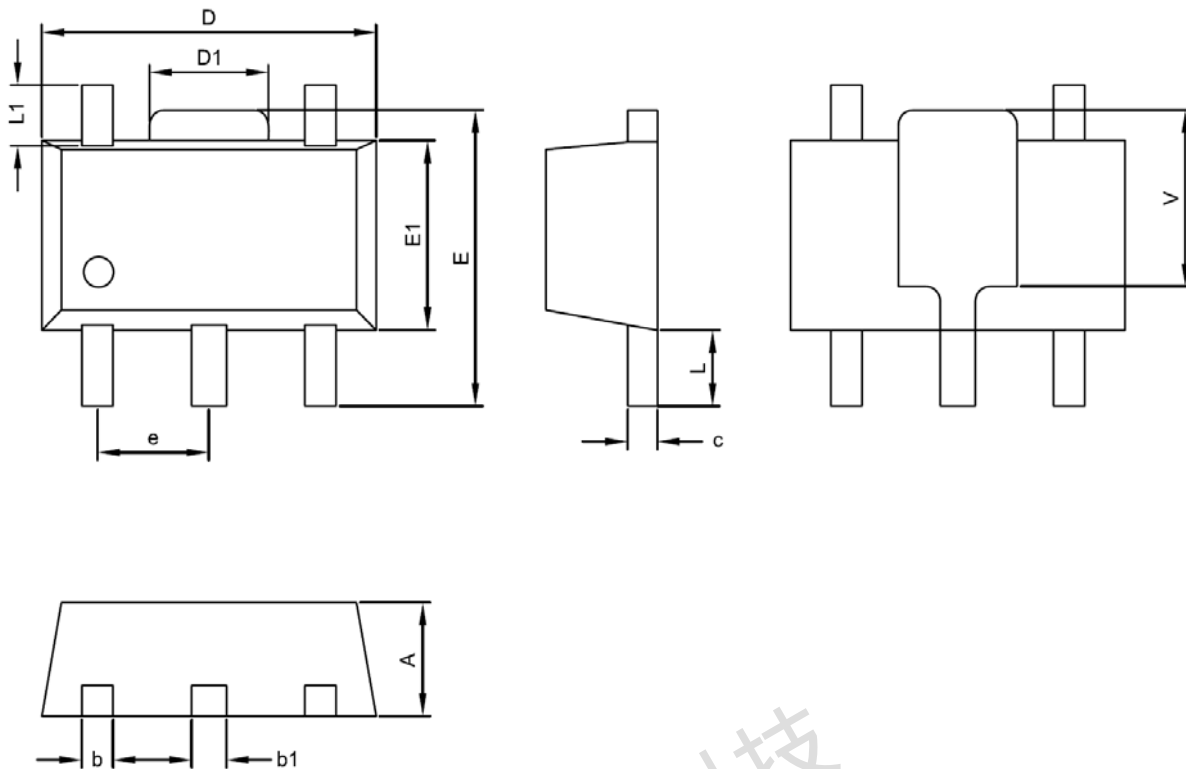

**SOT-89-5 (TE) Package**

Symble	DIMENSION IN MM			DIMENSION IN INCH		
	MIN.	NOM.	MAX.	MIN.	NOM.	MAX.
A	1.40	1.50	1.60	0.055	0.059	0.063
D	4.40	4.50	4.60	0.173	0.177	0.181
D1	1.40	1.60	1.75	0.055	0.063	0.069
E	3.85	4.05	4.25	0.152	0.159	0.167
E1	2.40	2.50	2.60	0.094	0.098	0.102
c	0.38	0.40	0.43	0.015	0.016	0.017
b	0.36	0.42	0.48	0.014	0.017	0.019
b1	0.41	0.47	0.53	0.016	0.019	0.021
e	1.50 BSC			0.059 BSC		
L	0.85	0.95	1.10	0.033	0.037	0.043
L1	0.60	0.80	0.90	0.024	0.031	0.035
V	2.60 BSC			0.102 BSC		

**Package Specification**

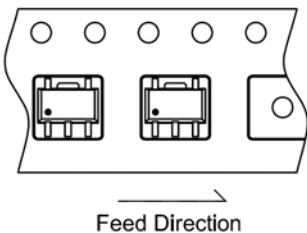

PACKAGE	Q'TY/REEL
SOT-89-5	1,000 ea

GMT Inc. does not assume any responsibility for use of any circuitry described, no circuit patent licenses are implied and GMT Inc. reserves the right at any time without notice to change said circuitry and specifications