

## High Efficiency, Constant Current 36V LED driver

### Features

- Operating Voltage: 7V to 36V.
- Shutdown Current <20  $\mu$ A(Typ).
- Analog Dimming Control.
- Digital Dimming Control.
- LED Thermal Overload Protection.
- Open LED Protection.
- MSOP-8 and MSOP-8 (FD) Package.

### General Description

The G2605 is a step-down converter, designed for driving high-brightness LED. The device operates over a 7V to 36V input voltage and driving current from few milliamps up to several amps.

The device built-in Overload Protection to prevent operating fails condition.

### Applications

- GPS Navigation System.
- Compact Back Light Module.
- Constant Current Source.
- LED Module

### Ordering Information

ORDER NUMBER	MARKING	TEMP. RANGE	PACKAGE (Green)
G2605P81U	G2605	-30°C to +105°C	MSOP-8
G2605F51U	G2605	-30°C to +105°C	MSOP-8 (FD)

Note: P8: MSOP-8 F5:MSOP-8 (FD)

1: Bonding Code

U: Tape & Reel

### Pin Configuration

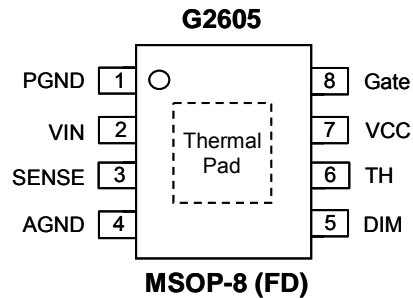
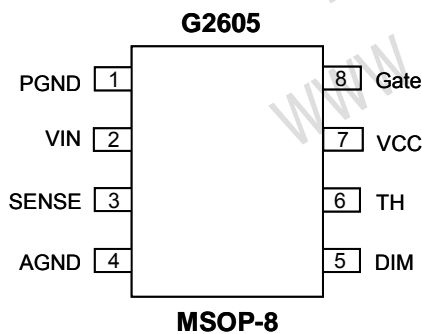

Note: Recommend connecting the Thermal Pad to the Ground for excellent power dissipation.

## Absolute Maximum Ratings

VIN, SENSE to GND. . . -0.3V to +40V(42V for 0.5 sec)
DIM, TH, VCC, Gate to GND. . . . . -0.3V to 6V
Thermal Resistance of Junction to Ambient ( $\theta_{JA}$ )
MSOP-8 . . . . . 180°C/W <sup>(1)</sup>
MSOP-8 (FD) . . . . . 120°C/W <sup>(2)</sup>
Continuous Power Dissipation ( $T_A = +25^\circ\text{C}$ )
MSOP-8. . . . . 0.69W <sup>(1)</sup>
MSOP-8 (FD) . . . . . 1.04W <sup>(2)</sup>

Thermal Resistance Junction to Case, ( $\theta_{JC}$ )
MSOP-8 . . . . . 38°C/W
MSOP-8 (FD) . . . . . 60°C/W
Operating Temperature. . . . . -30 to 105°C
Junction Temperature. . . . . 150°C
Storage Temperature. . . . . -65°C to 125°C
Reflow Temperature (soldering, 10sec) . . . . . 260°C
ESD Susceptibility
HBM. . . . . 2kV
MM. . . . . 200V

Note:

<sup>(1)</sup>: Please refer to Minimum Footprint PCB Layout Section.

<sup>(2)</sup>: Please refer to 1in<sup>2</sup> of 1oz PCB Layout Section.

## Electrical Characteristics

(VIN=12V, L=47μH, 1\*LED, LED Current=370mA, TA=+25°C)

The device is not guaranteed to function outside its operating conditions. Parameters with MIN and/or MAX limits are 100% tested at +25°C, unless otherwise specified.

Parameter	Symbol	Condition	Min.	Typ.	Max.	Unit
Input voltage	V <sub>IN</sub>		7	---	36	V
Under Voltage Threshold	V <sub>SU</sub>	V <sub>IN</sub> rising.	---	6.0	---	V
	V <sub>SD</sub>	V <sub>IN</sub> falling.	---	5.5	---	V
Quiescent supply current with output off	I <sub>INQoff</sub>	V <sub>DIM</sub> < 0.18V.	---	20	40	μA
Quiescent supply current with output switching	I <sub>INQon</sub>	DIM pin floating, f=250kHz.	---	1.8	5.0	mA
Mean current sense threshold voltage(Defines LED current setting accuracy)	V <sub>SENSE</sub>	Measured on SENSE pin with respect to V <sub>IN</sub> . L=47μH, I <sub>OUT</sub> =370mA.	95	100	105	mV
Sense threshold hysteresis	V <sub>SENSEHYS</sub>		---	±15	---	%
SENSE pin input current	I <sub>SENSE</sub>	V <sub>SENSE</sub> =V <sub>IN</sub> -0.1V	---	5	10	μA
Gate Pull High Resistance	R <sub>Gate,hi</sub>	PMOS on resistance	---	12	---	Ω
Gate Pull Low Resistance	R <sub>Gate,lo</sub>	NMOS on resistance	---	4.2	---	Ω
Operating frequency	f <sub>LX</sub>	DIM floating, L=47μH, I <sub>OUT</sub> =370mA.	---	420	---	kHz
VCC Output Voltage	V <sub>CC</sub>		---	5.0	---	V
VCC Output Current	I <sub>CC</sub>		---	---	0.5	mA
DIM Input level	Logic High	V <sub>DIM_H</sub>	1.3	---	---	V
	Analog DIM	V <sub>DIM_DC</sub>	0.3	---	1.23	V
	Logic Low	V <sub>DIM_L</sub>	---	---	0.18	V
Thermal protection Input level	V <sub>TH</sub>		---	0.082 * V <sub>CC</sub>	---	V
DIM Low Shutdown Delay	t <sub>d,DIM</sub>		---	10	---	ms
Thermal Shutdown	T <sub>sd</sub>		---	150	---	°C
Thermal Shutdown Hysteresis			---	30	---	°C
Minimum ON time	t <sub>ON_min</sub>	LX switch on.	---	240	---	ns
Minimum OFF time	t <sub>OFF_min</sub>	LX switch off.	---	300	---	ns

**Minimum Footprint PCB Layout Section**

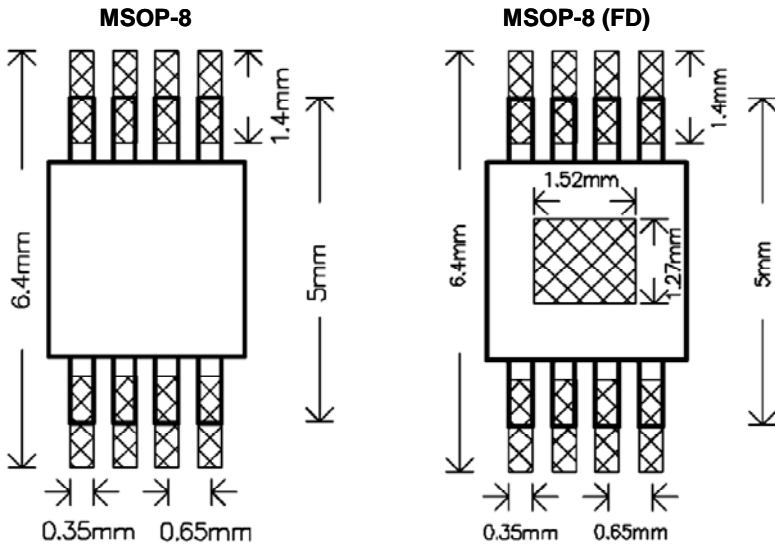

**1in<sup>2</sup> of 1oz PCB Layout Section**

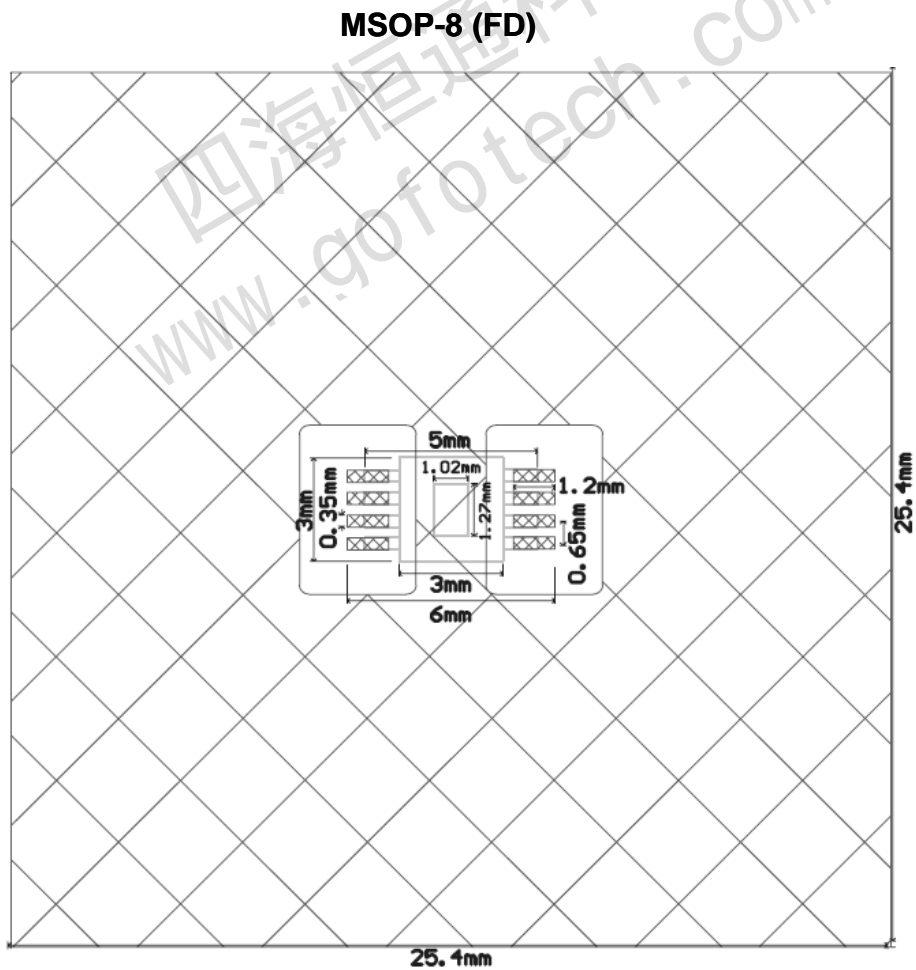

## Pin Description

PIN	NAME	FUNCTION
1	PGND	Power ground pin.
2	VIN	Input voltage.
3	SENSE	Connect resistor $R_s$ from this pin to VIN to define nominal average output current.
4	AGND	Ground
5	DIM	Dimming and Shutdown pin. 1. For automatic startup, leave SHDN unconnected. 2. Drive to voltage below 0.2V to turn off LED Current.
6	TH	Thermal protection pin. Connect thermistor (NTC) from this pin to GND.
7	VCC	Reference Voltage for Thermal protection.
8	Gate	Power MOS gate voltage output.
EP	EP	Exposed pad. * EP must connected to GND.

## Block Diagram

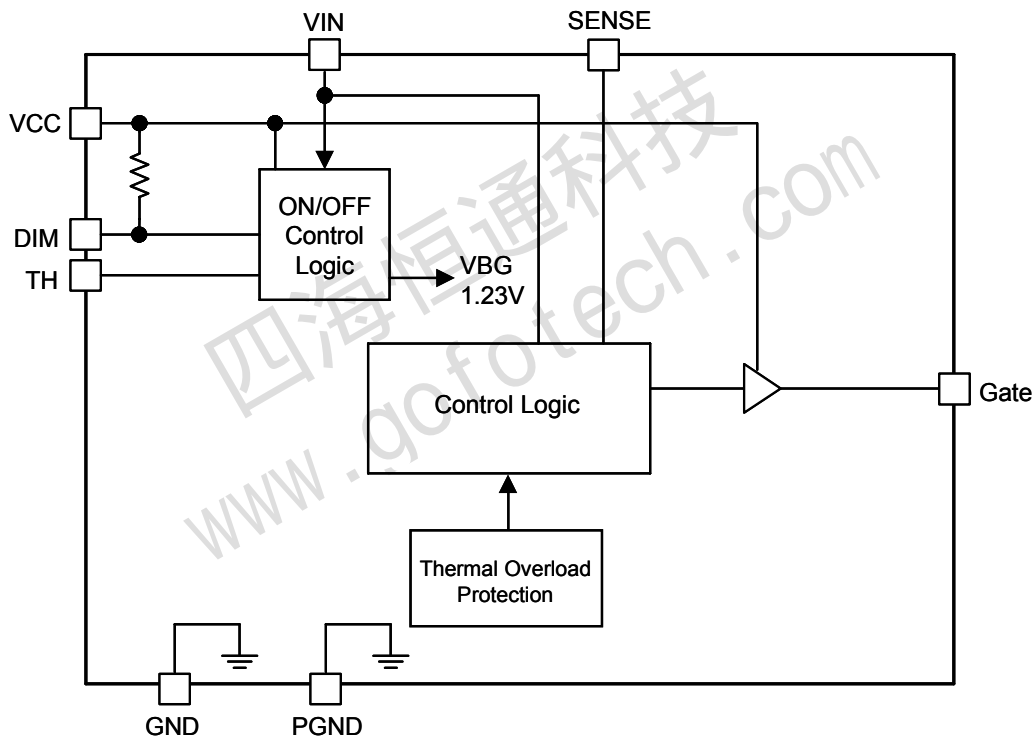

Fig. 3 Block Diagram of G2605

Application Information

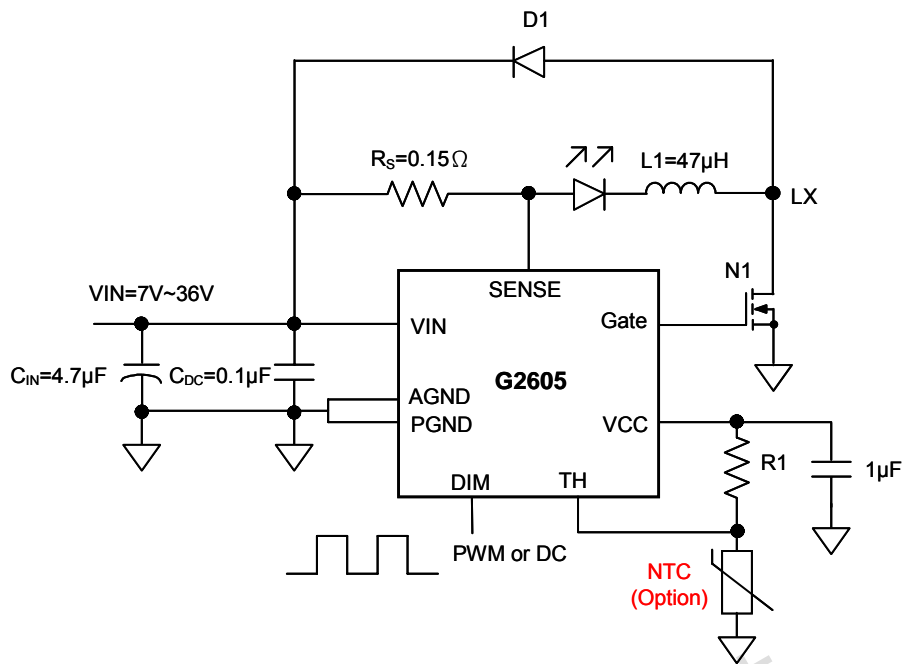

Fig. 1 Standard Application Circuit

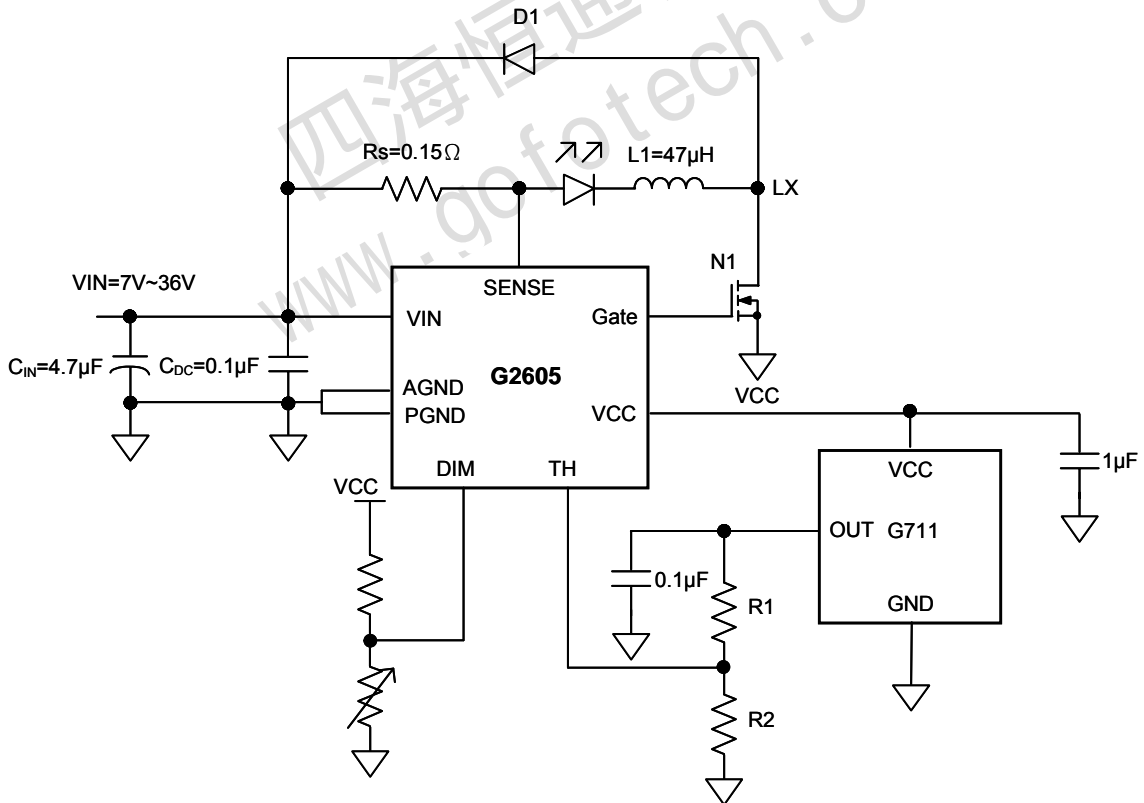

Fig. 2 Precisely LED Thermal Protect with G711

※ In figure 1, R1=22k(1%)、NTC(103IT) will shutdown LED at 75°C.

## Detailed Description

### Shutdown Control

Digital logic of DIM provides an electrical ON/OFF control of the power supply. Connecting this pin to ground or to any voltage less than 0.2V with more than 10ms will completely turn off the regulator. In this state, current drain from the input supply is less than 20 $\mu$ A (Typ.), the internal reference, error amplifier, comparators, and biasing circuitry turn off.

### Dimming Control

Digital logic of DIM provides LEDs brightness control by applying a PWM signal on DIM pin. With this way, the LEDs operate with either zero or full current. The average LED current is proportional to the duty-cycle of the PWM signal. Typical PWM frequency should be between 100Hz to 1kHz.

DC Input voltage of DIM also provides LEDs brightness control by applying a voltage signal between 0.3V to 1.23V on DIM pin. With this way, the LEDs operate with full 100% brightness corresponds to  $V_{DIM}$  equal or larger than 1.23V. When analog dimming is required, the DC voltage range of  $V_{DIM}$  should be between 0.3V to 1.23V.

If dimming control is not required, one could just left

DIM floating to turn on LEDs.

### Internal Thermal Shutdown

Thermal-overload protection limits total power dissipation in the G2605. When the junction temperature exceeds  $T_j=150^{\circ}\text{C}$ , a thermal sensor activates the thermal protection, which shutdowns the IC, allowing the IC to cool. Once the device cools down by  $30^{\circ}\text{C}$ , IC will automatically recover normal operation.

### Thermal Protection of LED

G2605 will turn off switching if the voltage of TH pin once lower than  $0.082 \times V_{CC}$  after  $V_{CC}$  reaches 90% of its value. If noise decoupling capacitor ( $C_{TH}$ ) is needed, it's value should be chosen by following equation:

$$(R_1 \parallel R_{NTC}) \times C_{TH} < 2.5 \times 10^{-6}$$

Once if G2605 enables TH protection, one should power on G2605 or toggle DIM low for 10ms then high again. Keep TH pin unconnected if Thermal protection not needed.

## Application Information

### Programming average LED current

The sense resistor ( $R_s$ ) and the sense voltage ( $V_{IN}-V_{sense}$ ) control the LED average current.

$$I_{LED} = \frac{0.1}{R_s}$$

LED Current(mA)	$R_s(\Omega)$
350mA	0.285
700mA	0.142
1000mA	0.1

In order to have accurate LED current, precision resistors are preferred (1% is recommend).

### Operating Frequency

$$f_s = \frac{1}{T_{ON} + T_{OFF}}$$

Where:

$f_s$  is operating frequency  
 $T_{ON}$  is LX on time  
 $T_{OFF}$  is LX off time

LX on time

$$T_{ON} = \frac{L\Delta I_L}{V_{IN} - V_{LED} - I_{LED}(R_s + r_L + R_{LX(ON)})}$$

$T_{ONmin} > 250ns$

LX off time

$$T_{OFF} = \frac{L\Delta I_L}{V_{LED} + V_D + I_{LED}(R_s + r_L)}$$

$T_{OFFmin} > 250ns$

Where:

$V_{IN}$  is the Input Voltage  
 $V_{LED}$  is the total LED forward voltage  
 $I_{LED}$  is the LED average current  
 $R_s$  is the current sense resistance  
 $r_L$  is the inductor resistance  
 $R_{LX(ON)}$  is the LX on resistance (0.5 $\Omega$  assumed.)  
 $L$  is the inductance  
 $\Delta I_L$  is the inductor peak-peak current (internally set to  $I_{avg} \times 0.3$ )

$V_D$  is the diode forward voltage at the LED average Current

Recommend operating frequency not more than 1MHz.

### Diode Selection

When the LX switch turns off, the current through the inductor continues to flow. The path for this current is through the diode connected between the LX switch and  $V_{IN}$ . This forward biased diode must have a minimum voltage drop and recovery times. Schottky diode is recommended and it should be able to handle those current. As usual, the reverse voltage rating of the diode should be at least 1.3 times greater than the maximum input voltage, and current rating is greater than the maximum load current.

### Diode Open

If the diode (D1) is open circuit, the energy stored in the inductor will drive LX voltage higher. The chip will be damaged if LX voltage higher than 40V. The diode can not be opened in use.

### Inductor Selection

Recommended inductor ( $L1$ ) values for the G2605 are in the range 22 $\mu H$  to 100 $\mu H$ .

Once an inductance value is determined from the frequency equation, the maximum operating current must be verified. Although peak-to-peak ripple current is controlled by the hysteresis value, there is some variation due to propagation delay. This means that the inductance has a direct effect on LED current line regulation. In general, a larger inductor will result in lower frequency and better line regulation.

### PC Board Layout

1. Power loops on the input and output of the converter should be laid out with the shortest and widest traces possible. The longer and narrower the trace, the higher resistance and inductance it will have. The length of traces in series with the capacitors increases its ESR and ESL and reduces their effectiveness at high frequency.
2. The SENSE pin should connect to sense resistors directly. And the route should be away from the noise source, such as inductor of LX line. Sense resistors must be placed as close as to the sense pin.

**Package Information**

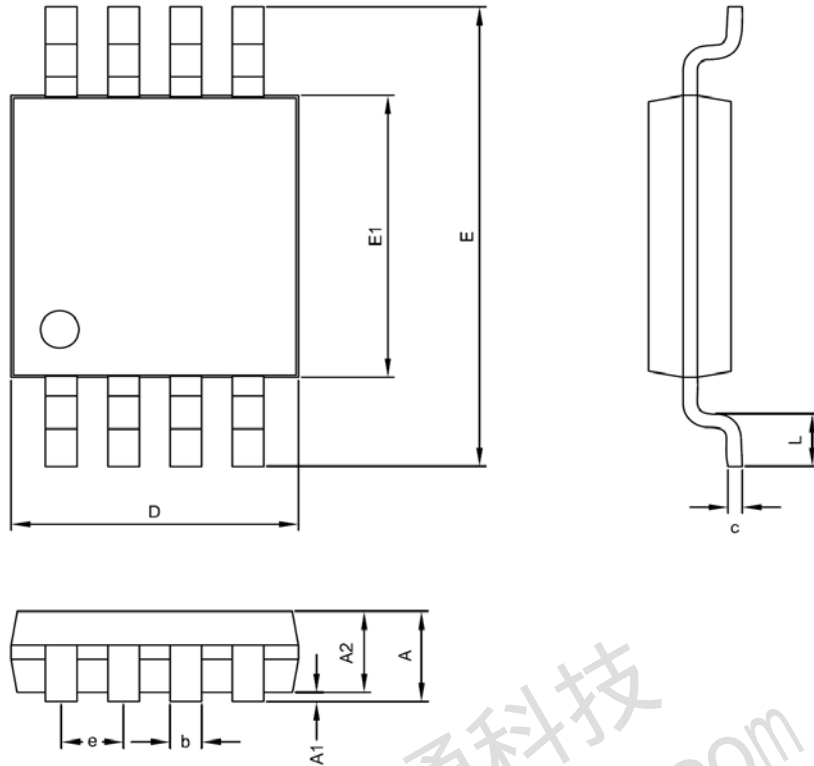

**MSOP-8 (P8) Package**

Symble	DIMENSION IN MM			DIMENSION IN INCH		
	MIN.	NOM.	MAX.	MIN.	NOM.	MAX.
A	0.81	0.95	1.10	0.032	0.037	0.043
A1	0.00	---	0.15	0.000	---	0.006
A2	0.76	0.86	0.96	0.030	0.034	0.038
D	2.90	3.00	3.10	0.114	0.118	0.122
E	4.80	4.90	5.00	0.189	0.193	0.197
E1	2.90	3.00	3.10	0.114	0.118	0.122
c	0.13	0.15	0.23	0.005	0.006	0.009
b	0.28	0.30	0.38	0.011	0.012	0.015
e	0.65 BSC			0.026 BSC		
L	0.4	0.53	0.8	0.016	0.021	0.026

**Taping Specification**

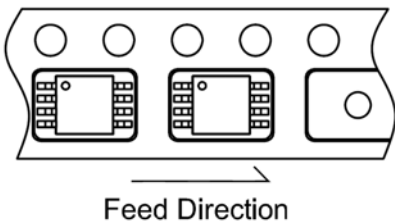

PACKAGE	Q'TY/REEL
MSOP-8	3,000 ea



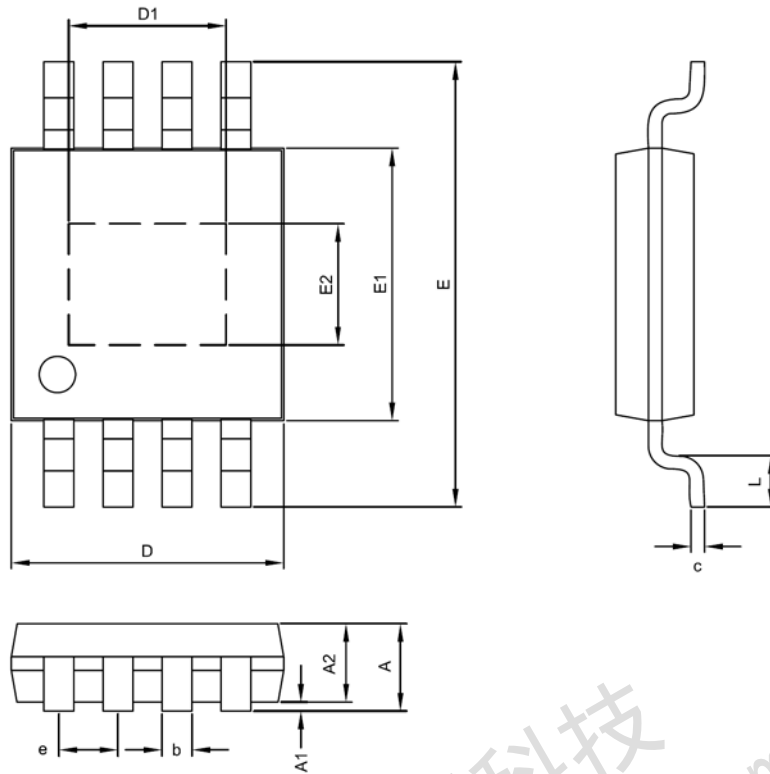

**MSOP-8 (FD) Package**

Symble	DIMENSION IN MM			DIMENSION IN INCH		
	MIN.	NOM.	MAX.	MIN.	NOM.	MAX.
A	0.81	0.95	1.10	0.032	0.037	0.043
A1	0.00	---	0.15	0.000	---	0.006
A2	0.76	0.86	0.96	0.030	0.034	0.038
D	2.90	3.00	3.10	0.114	0.118	0.122
D1	1.40	1.90	2.10	0.055	0.074	0.083
E	4.80	4.90	5.00	0.189	0.193	0.197
E1	2.90	3.00	3.10	0.114	0.118	0.122
E2	1.35	1.60	1.75	0.055	0.075	0.083
c	0.13	0.15	0.23	0.005	0.006	0.009
b	0.28	0.30	0.38	0.011	0.012	0.015
e	0.65 BSC			0.026 BSC		
L	0.4	0.53	0.8	0.016	0.021	0.026

**Taping Specification**

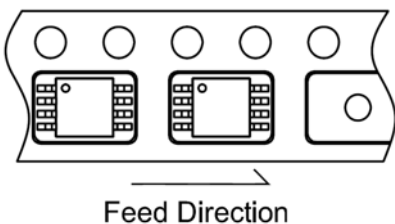

PACKAGE	Q'TY/REEL
MSOP-8 (FD)	3,000 ea

GMT Inc. does not assume any responsibility for use of any circuitry described, no circuit patent licenses are implied and GMT Inc. reserves the right at any time without notice to change said circuitry and specifications.