



# SS8392 High Efficiency DC-DC Boost Regulator

## Features

- Min1.6V Startup @1mA Load
- 600mV Feedback Voltage
- 1MHz Internal Oscillator
- Soft Startup: 10mS Typical
- Peak Current Programmable by Bottom Sensing Resistor
- 300 $\mu$ A Typical Iq
- Internal PWM/PFM Auto Mode Switching
- Up to 90% Efficiency
- External Enable
- Power OFF Current<1 $\mu$ A
- Over Voltage Protection

## Applications

- USB Charger

## General Description

The SS8392 using the external NMOSFET. It is a high efficiency boost converter with 600mV feedback voltage. A switching frequency of 1.0MHz minimizes solution footprint by allowing the use of tiny low profile inductors and ceramic capacitors. The

current mode PWM/PFM design is internally compensated, and the device has a 1.6V startup voltage with 1mA load. It needs few external components, only inductance, resistance and capacitance can meet the driving capacity.

## Block Diagram

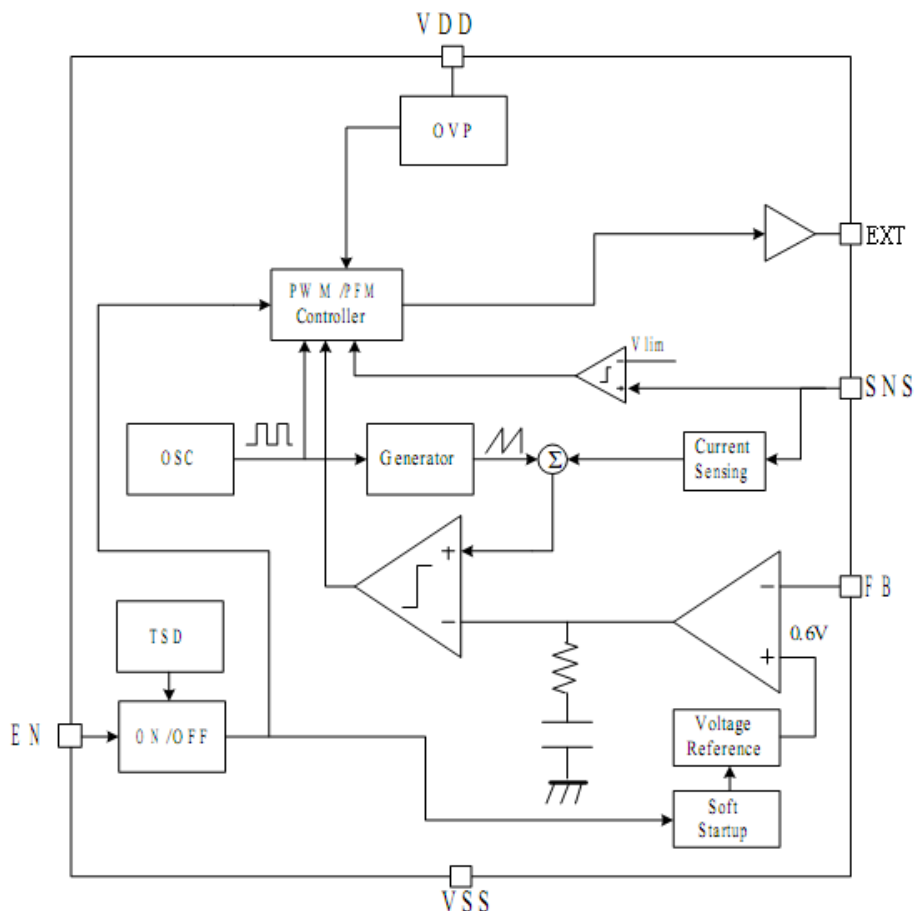

# SS8392 High Efficiency DC-DC Boost Regulator

---

## Pin Assignment

PIN NUMBER	PIN NAME	FUNCTION
1	FB	Feedback Input
2	GND	Power Ground
3	EN	Enable. High Active
4	VDD	Power Supply
5	SNS	Switching Node
6	EXT	Power MOSFET Gate Driver

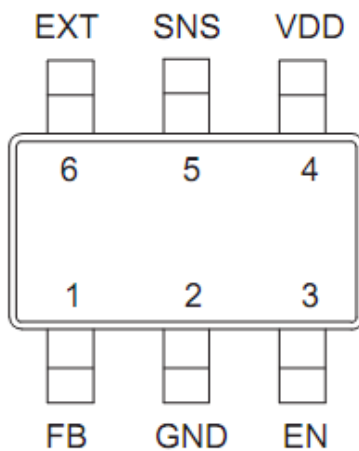

## Absolute Maximum Ratings

Power Supply Voltage ..... 2.8V to 7.0V      Quiescent Current ..... 450uA  
Feedback Voltage .....600mV

Note: These are stress ratings only. Stresses exceeding the range specified under “Absolute Maximum Ratings” may cause substantial damage to the device. Functional operation of this device at other conditions beyond those listed in the specification is not implied and prolonged exposure to extreme conditions may affect device reliability.

## Thermal Information

Implementation of integrated circuits in low-profile and fine-pitch surface-mount packages typically requires special attention to power dissipation. Many system-dependent issue such as thermal coupling, airflow, added heat sinks and convection surfaces, and the presence of other heat-generating components affect the power-dissipation limits of a given component.

Three basic approaches for enhancing thermal performance follow.

- Improving the power dissipation capability of the PCB design
- Improving the thermal coupling of the component to the PCB
- Introducing airflow in the system

# *SS8392 High Efficiency DC-DC Boost Regulator*

## Electrical Characteristics

(VDD = 5 V, Ta = 25°C, Unless otherwise specified)

PARAMETER	SYMBOL	MIN	TYP	MAX	UNITS	CONDITION
Power Supply Voltage for normal operation	VDD	2.8		7	V	For normal operation after start-up
Min Input Startup Voltage	VST1		1.6		V	1mA load, VDD tied to VOUT
Input Startup Voltage with Heavy Load	VST2		2.6		V	VDD tied to VOUT
Min Input Hold Voltage	VHLD	0.9			V	VDD tied to VOUT
Feedback Voltage	VFB		600		mV	
Feedback Voltage Temperature Coefficient	VFBTC		130		ppm/°C	
Feedback Voltage Supply Regulation	Vreg		0.2		%/V	Close Loop. Varying VDD by adjusting Resistor Divider Ratio
Load Regulation	Ireg		0.3		%/A	
Quiescent Current	Iq		350		µA	No Switching
OFF current	Ioff		1		µA	
Oscillator Frequency	fosc		1		MHz	
Max Duty	Dmax		90		%	
Duty boundary for PWM/PFM	Dmin		15		%	
Current Limit Set Voltage	Vlim		250		mV	
DRV PMOS On Resistor	Ronp		10		Ohm	Min measured at 3V VDD
DRV NMOS On Resistor	Ronn		7.5		Ohm	Min measured at 3V VDD
DRV PMOS Max Output Current	Imaxp		230		mA	Min measured at 3V VDD
DRV NMOS MAX Output Current	Imaxn		190		mA	Min measured at 3V VDD
FB OVP Threshold	Vovp		720		mV	Measured at FB
FB OVP Hysteresis	Vophys		100		mV	Measured at FB
TSD Threshold	TSD		140		degc	
TSD Hysteresis	TSDhs		20		degc	
EN High Level	VH	1			V	
EN Low Level	VL			0.3	V	
Soft Start Time	Tss		10		mS	VIN=1.5V, VOUT=5V, LOAD=1mA

# SS8392 High Efficiency DC-DC Boost Regulator

## Application Circuits

### 1) Power supply tied to VOUT

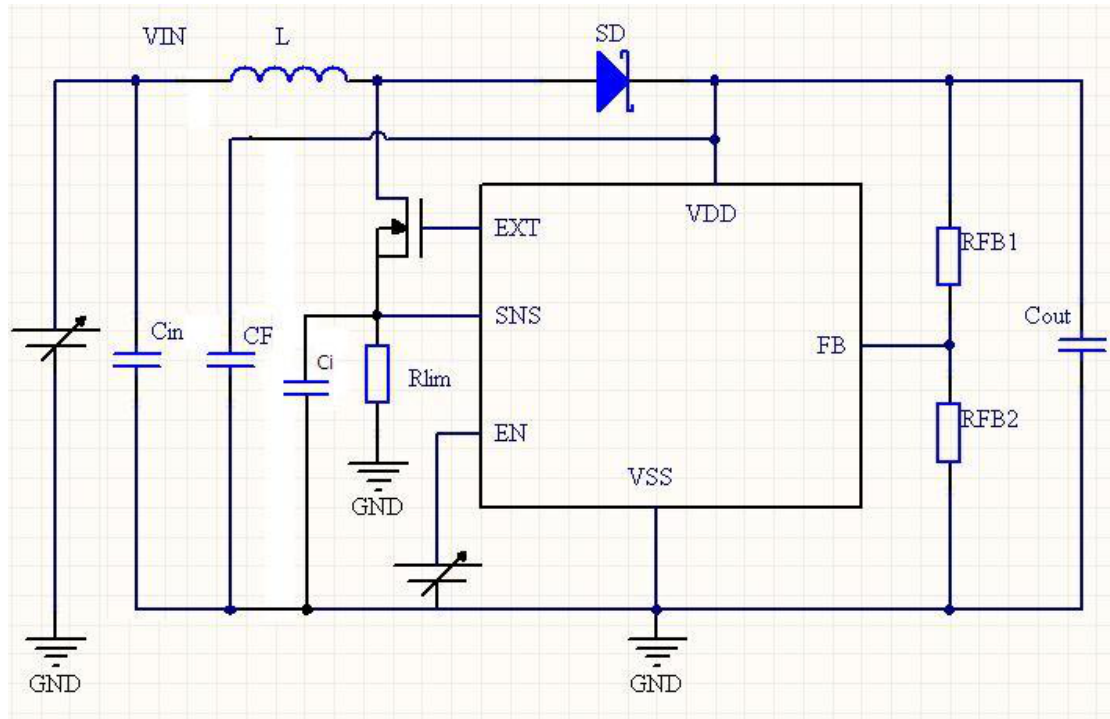

### 2) Power supply tied to VIN(VIN>2.8V)

### 3) External Component Recommendation:

- 1)  $R_{lim}=50\text{m}\Omega$  \*(2)
- 2)  $C_{in}=22\mu\text{F}$
- 3)  $C_{out}=22\mu\text{F}$  \*(1)
- 4)  $L=2.2\mu\text{H}$
- 5)  $C_f=0.1\mu\text{F}$
- 6)  $C_i=0.1\mu\text{F}$

\*(1)  $C_{out}$  needs to increase when reducing  $R_{lim}$  value. For example,  $R_{lim}=25\text{m}\Omega \rightarrow C_{out}=22\mu\text{F}$

\*(2) Selection table

Test Condition: $V_{in}=3.3\text{V}$ , $V_{out}=5\text{V}$ , $L=2.2\mu\text{H}$	
$R_{lim}$ (m $\Omega$ )	Max load current (A)
200	0.5
100	1.3
50	2.6

## Package Information

### 6-pin SOT23-6 Outline Dimensions

# SS8392 High Efficiency DC-DC Boost Regulator

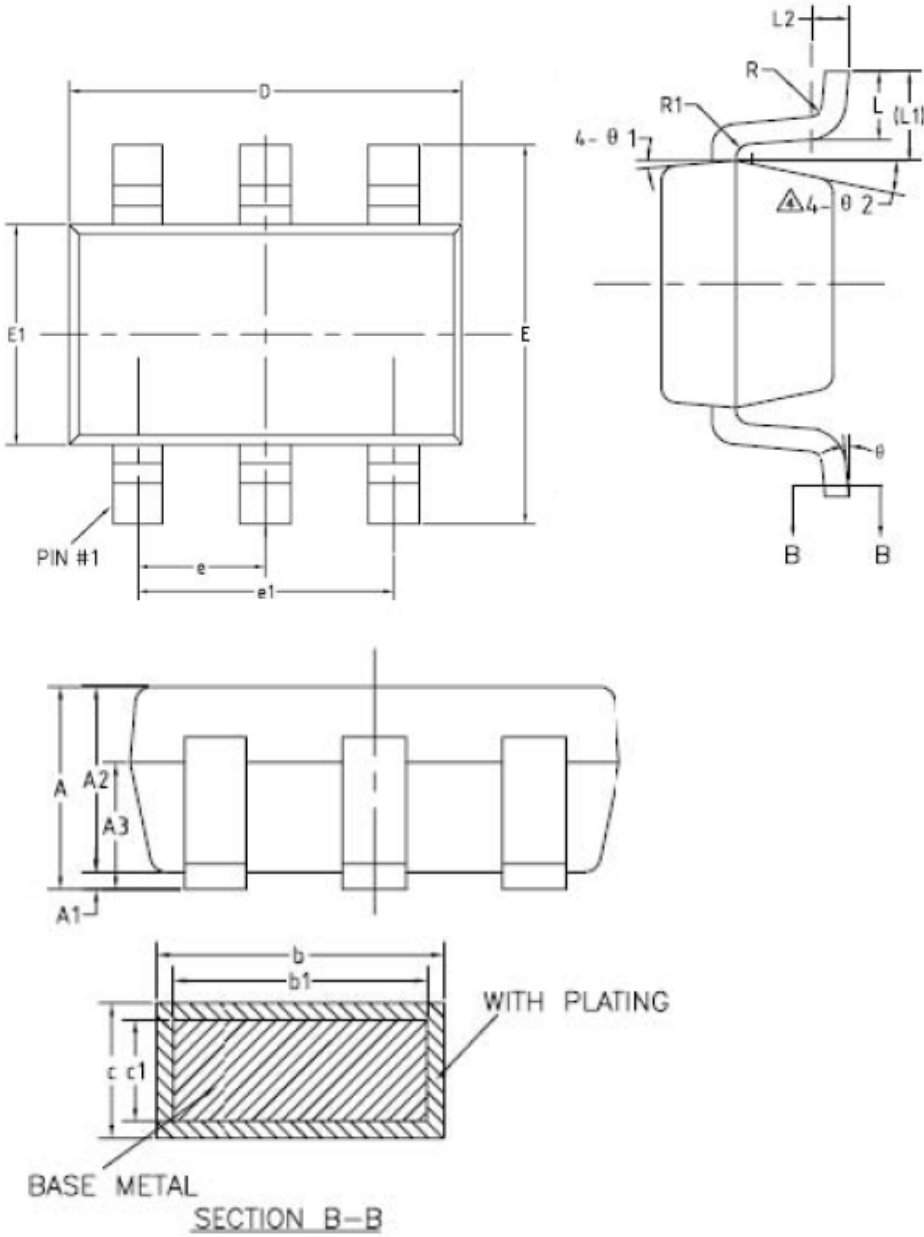

# *SS8392 High Efficiency DC-DC Boost Regulator*

---

COMMON DIMENSIONS  
(UNITS OF MEASURE=MILLIMETER)

SYMBOL	MIN	NOM	MAX
A	—	—	1.25
A1	0	—	0.15
A2	1.00	1.10	1.20
A3	0.60	0.65	0.70
b	0.36	—	0.50
b1	0.36	0.38	0.45
c	0.14	—	0.20
c1	0.14	0.15	0.16
D	2.826	2.926	3.026
E	2.60	2.80	3.00
E1	1.526	1.626	1.726
△ e	0.90	0.95	1.00
△ e1	1.80	1.90	2.00
L	0.35	0.45	0.60
L1	0.59REF		
L2	0.25BSC		
△ R	0.10	—	—
△ R1	0.10	—	0.20
θ	0°	—	8°
θ 1	3°	5°	7°
△ θ 2	6°	—	14°