



DESIGN EXAMPLE REPORT

Title	<i>7 W (10 W peak) 3 Output Supply Using LNK626PG</i>
Specification	85 – 265 VAC Input; 5 V / 1.7 A, 12 V / 0.1 A, and -22 V / 15 mA Outputs
Application	DVD Player
Author	Applications Engineering Department
Document Number	DER-198
Date	November 11, 2008
Revision	1.0

Summary and Features

- Revolutionary control concept provides very low cost, low part-count solution
 - Primary-side control eliminates secondary-side control and optocoupler
 - Provides $\pm 5\%$ constant voltage (CV) accuracy
 - Over-temperature protection – tight tolerance ($\pm 5\%$) with hysteretic recovery for safe PCB temperatures under all conditions
 - Auto-restart output short circuit and open-loop protection
 - Extended pin creepage distance for reliable operation in humid environments – >3.2 mm at package
- EcoSmart® – Easily meets all current international energy efficiency standards – China (CECP) / EISA / ENERGY STAR 2 / EU CoC
 - Ultra-low leakage current: $<5 \mu\text{A}$ at 265 VAC input (no Y capacitor required)
 - Design easily passes EN55022 and CISPR-22 Class B EMI testing with >10 dB margin
- Meets IEC 61000-4-5 Class 3 AC line surge
- Meets IEC 61000-4-2 ESD withstand (contact and air discharge to ± 15 kV)

PATENT INFORMATION

The products and applications illustrated herein (including transformer construction and circuits external to the products) may be covered by one or more U.S. and foreign patents, or potentially by pending U.S. and foreign patent applications assigned to Power Integrations. A complete list of Power Integrations' patents may be found at www.powerint.com. Power Integrations grants its customers a license under certain patent rights as set forth at <http://www.powerint.com/ip.htm>.

Power Integrations

5245 Hellyer Avenue, San Jose, CA 95138 USA.

Tel: +1 408 414 9200 Fax: +1 408 414 9201

www.powerint.com

Table of Contents

1	Introduction.....	4
2	Power Supply Specification	5
3	Schematic.....	6
4	Circuit Description	7
4.1	Input Section	7
4.2	Input Filter	7
4.3	Primary Clamp.....	8
4.4	Feedback.....	8
4.5	Optional Bias Circuit.....	9
4.6	LinkSwitch-CV Bypass Capacitor	9
4.7	Output Rectifiers and Filters	9
4.8	Output Y Capacitor	9
5	PCB Layout	10
6	Bill of Materials	11
7	Transformer Specification.....	12
7.1	Electrical Diagram	12
7.2	Electrical Specifications.....	12
7.3	Materials.....	12
7.4	Transformer Build Diagram	13
8	Transformer Spreadsheets.....	14
9	Performance Data	17
9.1	Efficiency.....	17
	No-load Input Power	18
9.2	Available Standby Output Power	19
9.3	Regulation	20
9.3.1	Load Regulation	20
9.3.2	Cross Regulation.....	21
10	Thermal Performance	24
11	Waveforms.....	25
11.1	Drain Voltage and Current, Normal Operation.....	25
11.2	Output Voltage Start-up Profile.....	25
11.3	Drain Voltage and Current Start-up Profile	26
11.4	Load Transient Response (50% to 100% Load Step)	27
11.5	Output Ripple Measurements.....	28
11.5.1	Ripple Measurement Technique	28
11.5.2	Measurement Results	29
12	Line Surge.....	31
13	Conducted EMI	32
14	Audible Noise.....	34
	Revision History	36



Important Note:

Although this board is designed to satisfy safety isolation requirements, the engineering prototype has not been agency approved. Therefore, all testing should be performed using an isolation transformer to provide the AC input to the prototype board.



1 Introduction

This document is an engineering report describing a DVD Player power supply utilizing a LNK626. This power supply is intended as a general purpose evaluation platform for LinkSwitch-CV.

The document contains the power supply specification, schematic, bill of materials, transformer documentation, printed circuit layout, and performance data.

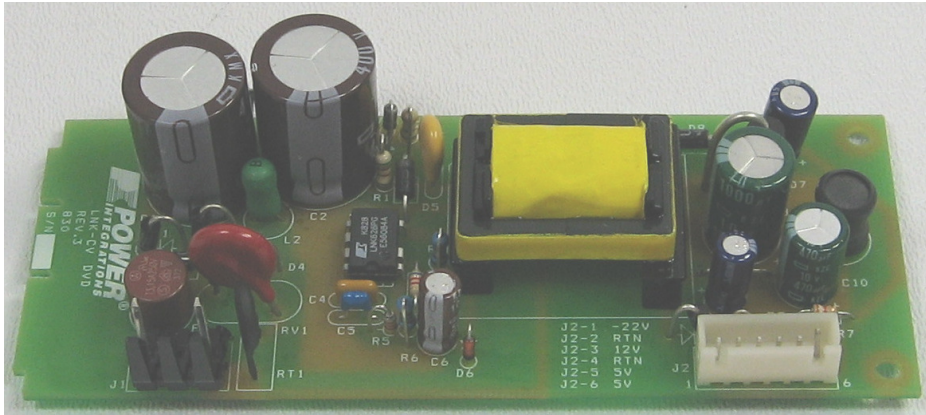

Figure 1 – Populated Circuit Board Photograph.

2 Power Supply Specification

Description	Symbol	Min	Typ	Max	Units	Comment
Input						
Voltage	V_{IN}	85		265	VAC	2 Wire – no P.E.
Frequency	f_{LINE}	47	50/60	64	Hz	
No-load Input Power (230 VAC)				0.14	W	
Output						
Output Voltage 1	V_{OUT1}	4.75	5.0	5.25	V	± 5%
Output Ripple Voltage 1	$V_{RIPPLE1}$			100	mV	20 MHz bandwidth
Output Current 1	I_{OUT1}	0.05		1.7	A	Peak
Output Voltage 2	V_{OUT2}	10.8	12	13.2	V	± 10%
Output Ripple Voltage 2	$V_{RIPPLE2}$			750	mV	20 MHz bandwidth
Output Current 2	I_{OUT2}	0.05		0.1	A	
Output Voltage 3	V_{OUT3}	-19.8	-22	-24.2	V	± 10%
Output Ripple Voltage 3	$V_{RIPPLE3}$			200	mV	20 MHz bandwidth
Output Current 3	I_{OUT3}	5		15	mA	
Total Output Power						
Continuous Output Power	P_{OUT}			7	W	
Peak Output Power	P_{OUT_PEAK}			10	W	
Efficiency						
Full Load	η	68.0			%	Measured at P_{OUT} 25 °C
Environmental						
Conducted EMI		Meets CISPR22B / EN55022B				Output Floating
Safety		Designed to meet IEC950 / UL1950				
Surge		Class II				
Differential (L1-L2)		2			kV	1.2/50 μ s surge (per IEC 1000-4-5) Series Impedance: 12 Ω Common Mode 2 Ω Differential Mode
Common Mode (L1/L2-PE)		6			kV	
100 kHz ring wave (L1/L2-PE)		6			kV	
Ambient Temperature	T_{AMB}	0		40	°C	Free convection, sea level



3 Schematic

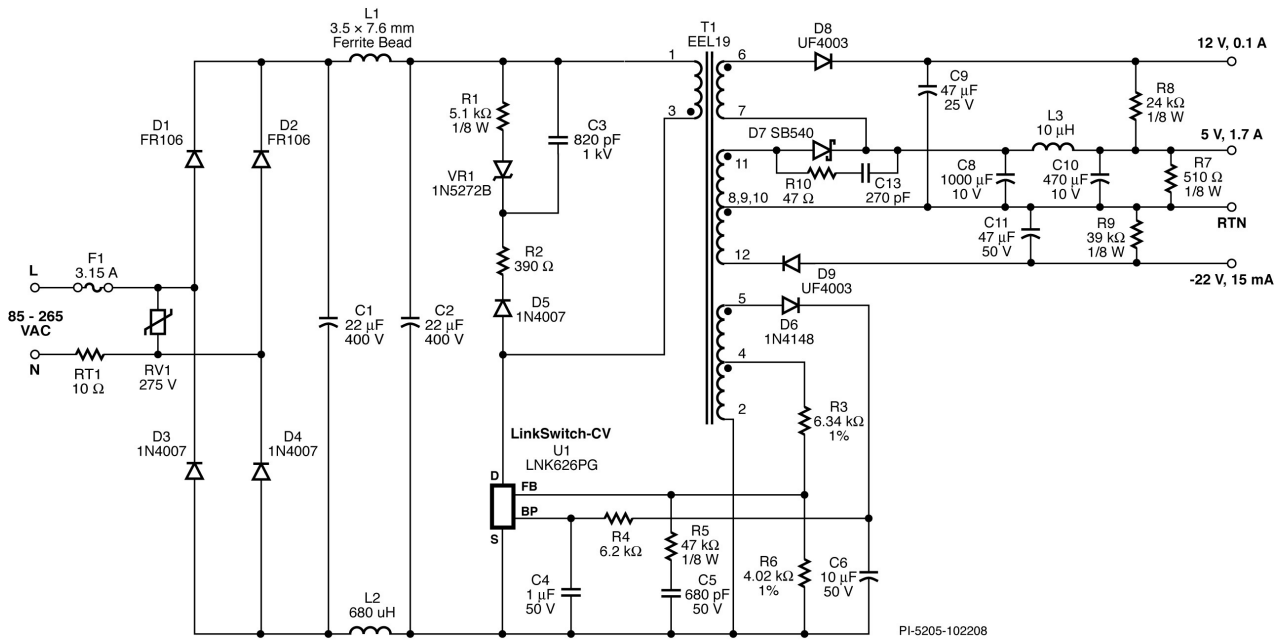

Figure 2 – Schematic.

4 Circuit Description

The LNK626PG was developed to be a cost effective solution in DVD Players, white goods, chargers or any application requiring a regulated constant voltage (CV) output. The LNK626PG has a monolithically integrated 700 V switching MOSFET and ON/OFF control function which together deliver high efficiency under all load conditions and low no-load energy consumption. Both the operating efficiency and no-load performance exceed all current international energy efficiency standards.

The LNK626PG controller consists of an oscillator, a feedback (sense and logic) circuit, a 5.8 V regulator, over-temperature protection, frequency jittering, a current-limit circuit, leading-edge blanking and an ON/OFF state machine for CV control.

The LNK626PG also provides a sophisticated range of protection features including auto-restart for control loop component open/short circuit faults and output short circuit conditions. Accurate hysteretic thermal shutdown ensures safe average PCB temperatures under all conditions.

The IC package provides extended creepage distance between high and low voltage pins (both at the package and PCB), which is required in highly humid environments to prevent arcing and to further improve reliability.

The LNK626PG can be configured to either be self-biased from the high-voltage DRAIN pin, or to receive an optional external bias supply. When configured to be self-biased, the very low IC current consumption ensures a worst-case no-load power consumption of less than 200 mW at 230 VAC. With external bias, <70 mW is achievable.

This document contains the power supply specifications, schematic, bill of materials, transformer specifications, and typical performance characteristics for this reference design.

4.1 Input Section

Fuse F1 provides input current protection in case of a primary side component failure. Thermistor RT1 limits the inrush current when power is applied to the circuit. Metal oxide varistor RV1 provides differential line input surge protection, for surges greater than 2 kV. Below this level, RV1 may be omitted. Diodes D1 through D4 rectify the AC input, with D1 and D2 selected as a fast (500 ns) recovery to improve conducted EMI.

4.2 Input Filter

The AC input voltage is rectified by diodes D1 through D4 and filtered by C1 and C2. Capacitors C1 and C2 together with L1 and L2 form a pi (π) filter to attenuate conducted EMI.



4.3 Primary Clamp

The drain clamp network is formed by R1, R2, C3, D5 and VR1. This network limits the leakage inductance inducted drain voltage spike. However unlike secondary side feedback the drain clamp design also affects the output regulation and ripple performance.

Any ringing on the drain node also appears on the feedback winding and is therefore sampled by the FEEDBACK pin of U1. This can create an error between the output voltage and the sampled voltage seen by U1. This degrades regulation and output ripple. Sampling occurs between 2.1 μs and 3.4 μs after the primary switch turn off. Therefore ideally the drain voltage should settle to within ~1% of it's final value (equal to V_{OR}) 2.1 μs after turn off of the internal MOSFET.

The goal of the clamp design is to reduce drain node ringing while limiting the peak drain voltage and minimizing dissipation for high efficiency and low no-load input power consumption. To meet this set of goals a Zener bleed clamp configuration was used. This is a RCD clamp where the resistor is replaced by the series combination of a resistor (R1) and low power Zener (VR1). The addition of the Zener prevents the clamp capacitor (C3) from being discharged below the Zener voltage rating at light or no-load that would normally occur with a standard RCD clamp. This improves light load efficiency and reduces no-load input power. The instantaneous current through VR1 is limited by R1 allowing a standard low cost, low power Zener (versus a transient voltage suppressor type).

The value of VR1 is typically set 0%-20% above the value of V_{OR} (the output voltage reflected through the transformer turns ratio). Here it was chosen as 110 V the same as the V_{OR} to give the best possible output regulation. The value of R1 was selected to discharge C3 to the value of VR1 in 2.1 μs .

In designs with higher transformer leakage inductance the value of R1 may need to be increased to keep the dissipation of VR1 acceptable. For designs with primary leakage inductance lower than ~100 μH , VR1 may be replaced with a single resistor in the range of 100 k Ω to 470 k Ω .

To prevent high frequency ringing D5 was selected as a standard recovery diode versus a fast or ultra-fast type. Resistor R2 acts to dampen the drain ringing, the value being chosen to dampen the drain ring to an acceptable level while keeping the peak drain voltage to below the BV_{DSS} of the internal MOSFET.

4.4 Feedback

The ratio of R3 to R6 sets the output voltage level. The starting values are provided by the PI Xls design software. In some designs, C5 and R5 are required to eliminate excessive output ripple voltage caused by group pulsing. In LinkSwitch-CV applications, group pulsing is defined to be a group of five or more consecutive drain pulses followed



by four or more skipped pulses. The value of R5 should be greater than or equal to the value of $10 \times R6$. The value of $R5 \times C5 = 32 \mu\text{s}$ will provide optimum performance.

4.5 Optional Bias Circuit

Diodes D6, C6 and R4 along with a bias winding in the transformer provide an external bias supply. This circuit reduces the no load input power consumption to less than 150 mW (depending on the output preload resistor values) and increase efficiency. The components mentioned above may be removed if reduced no load input power and improved efficiency is not required.

4.6 LinkSwitch-CV Bypass Capacitor

LinkSwitch-CV requires a bypass capacitor of 1 μF minimum to bias the internal circuitry. The voltage rating must be greater than 6.8 V. Electrolytic, tantalum or ceramic dielectric may be used.

4.7 Output Rectifiers and Filters

Diodes D7 rectifies and C8, C10 and L3 filter the 5 V output. A diode rated at 5 A was chosen for D7 to improve cross regulation. If the cross regulation specification was relaxed or for single output applications, a smaller diode could be used. Resistor R10 and C13 form a snubber to reduce conducted and radiated EMI.

Diode D8 and C9 rectify and filter the 12 V output. Diode D9 and C11 rectify and filter the -22 V output. Preload resistors R7, R8 and R9 limit the output voltages to safe levels in the event that the outputs become unloaded.

4.8 Output Y Capacitor

Capacitor C12 was not required to meet conducted EMI for a floating output test configuration. Other test configurations may require the use of a Y capacitor.



5 PCB Layout

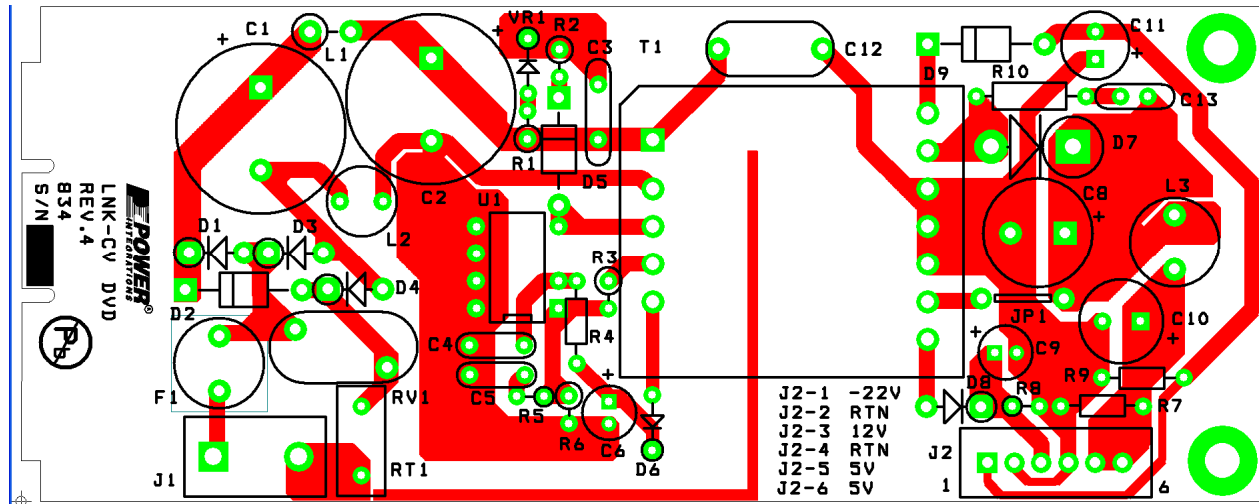

Figure 3 – Printed Circuit Layout.



6 Bill of Materials

Item	Qty	Ref Des	Description	Mfg Part Number	Mfg
1	2	C1 C2	22 μ F, 400 V, Electrolytic, Low ESR, 901 mOhm, (16 x 20)	EKMX401ELL220ML20S	Nippon Chemi-Con
2	1	C3	820 pF, 1 kV, Y5P, Disc Ceramic	ECK-A3A821KBP	Panasonic
3	1	C4	1.0 μ F, 50 V, Ceramic, Z5U	B37988G5105M000	Epcos
4	1	C5	680 pF, 50 V, Ceramic, COG	B37979G5681J000	Epcos
5	1	C6	10 μ F, 50 V, Electrolytic, Gen. Purpose, (5 x 11)	EKMG500ELL100ME11D	Nippon Chemi-Con
6	1	C8	1000 μ F, 10 V, Electrolytic, Very Low ESR, 38 m Ω , (10 x 16)	EKZE100ELL102MJ16S	Nippon Chemi-Con
7	1	C9	47 μ F, 25 V, Electrolytic, Low ESR, 500 m Ω , (5 x 11.5)	ELXZ250ELL470MEB5D	Nippon Chemi-Con
8	1	C10	470 μ F, 10 V, Electrolytic, Very Low ESR, 72 m Ω , (8 x 11.5)	EKZE100ELL471MHB5D	Nippon Chemi-Con
9	1	C11	47 μ F, 50 V, Electrolytic, Low ESR, 450 m Ω , (6.3 x 11.5)	ELXZ500ELL470MFB5D	Nippon Chemi-Con
10	1	C12	330 pF, Ceramic Y1	440LT33-R	Vishay
11	1	C13	270 pF, 50 V, Ceramic, COG	B37979N5271J000	Epcos
12	2	D1 D2	800 V, 1 A, Fast Recovery Diode, 500 ns, DO-41	FR106	Diodes Inc.
13	2	D3 D4	1000 V, 1 A, Rectifier, DO-41	1N4007-E3/54	Vishay
14	1	D5	1000 V, 1 A, Rectifier, DO-41	1N4007	Vishay
15	1	D6	75 V, 300 mA, Fast Switching, DO-35	1N4148	Vishay
16	1	D7	40 V, 5 A, Schottky, DO-201AD	SB540	Vishay
17	2	D8 D9	200 V, 1 A, Ultrafast Recovery, 50 ns, DO-41	UF4003-E3	Vishay
18	1	F1	3.15A, 250V, TIME-LAG HI-BREAK TR5	38213150410	Wickman
19	1	J1	2 Position (1 x 2) header, 0.312 pitch, Vertical	26-50-3039	Molex
20	1	J2	6 Position (1 x 6) header, 2.5 mm pitch, Vertical	DF1B-6P-2.5DSA	Hirose Electric Co
21	1	JP1	Wire Jumper, Insulated, 22 AWG, 0.3 in	C2004-12-02	Gen Cable
22	1	L1	3.5 mm x 7.6 mm, 75 Ω at 25 MHz, 22 AWG hole, Ferrite Bead	2743004112	Fair-Rite
23	1	L2	680 uH, 0.21 A, 7 x 10.5 mm	SBC2-681-211	Tokin
24	1	L3	10 uH, 3.0 A	R622LY-100K	Toko
25	1	R1	5.1 k Ω , 5%, 1/4 W, Carbon Film	CFR-25JB-5K1	Yageo
26	1	R2	390 Ω , 5%, 1/4 W, Carbon Film	CFR-25JB-390R	Yageo
27	1	R3	6.34 k Ω , 1%, 1/4 W, Metal Film	MFR-25FBF-6K34	Yageo
28	1	R4	6.2 k Ω , 5%, 1/8 W, Carbon Film	CFR-12JB-6K2	Yageo
29	1	R5	47 k Ω , 5%, 1/8 W, Carbon Film	CFR-12JB-47K	Yageo
30	1	R6	4.02 k Ω , 1%, 1/4 W, Metal Film	MFR-25FBF-4K02	Yageo
31	1	R7	510 Ω , 5%, 1/8 W, Carbon Film	CFR-12JB-510R	Yageo
32	1	R8	24 k Ω , 5%, 1/8 W, Carbon Film	CFR-12JB-24K	Yageo
33	1	R9	39 k Ω , 5%, 1/8 W, Carbon Film	CFR-12JB-39K	Yageo
34	1	R10	47 Ω , 5%, 1/4 W, Carbon Film	CFR-25JB-47R	Yageo
35	1	RT1	NTC Thermistor, 10 Ohms, 1.7 A	CL-120	Thermometrics
36	1	RV1	275 V, 80J, 10 mm, RADIAL	ERZ-V10D431	Panasonic
37	1	T1	Transformer, EEL19 Horizontal 12 pin (5/7).	Santronics	SNX R1464
38	1	U1	LinkSwitch-II, LNK626PG, CV/CC, DIP-8C	LNK626PG	Power Integrations
39	1	VR1	110 V, 5%, 500 mW, DO-35	1N5272B	Microsemi



7 Transformer Specification

7.1 Electrical Diagram

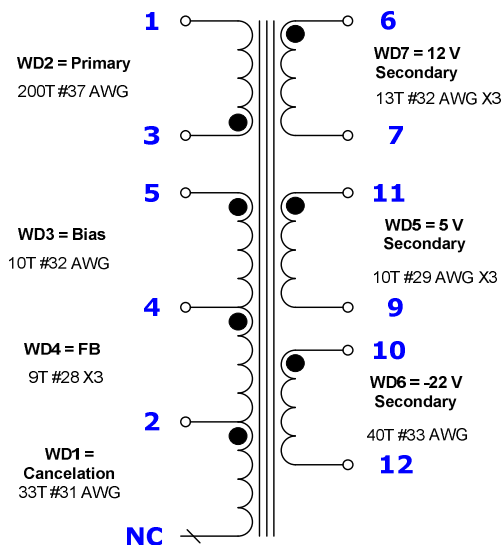

Figure 4 –Transformer Electrical Diagram.

7.2 Electrical Specifications

Electrical Strength	1 second, 60 Hz, from Pins 1-5 to Pins 6-12	4250 VAC
Primary Inductance	Pins 1-3, all other windings open, measured at 100 kHz, 0.4 VRMS	1.62 μ H, \pm 10%
Resonant Frequency	Pins 1-3, all other windings open	375 kHz (Min.)
Primary Leakage Inductance	Pins 1-3, with Pins 9-11 shorted, measured at 100 kHz, 0.4 VRMS	210 μ H (Max.)

7.3 Materials

Item	Description
[1]	Core: EEL19 PC40 or equivalent. Gapped to 40.5 nH/T ²
[2]	Bobbin: EEL19 Horizontal 12 pin (5/7).



7.4 Transformer Build Diagram

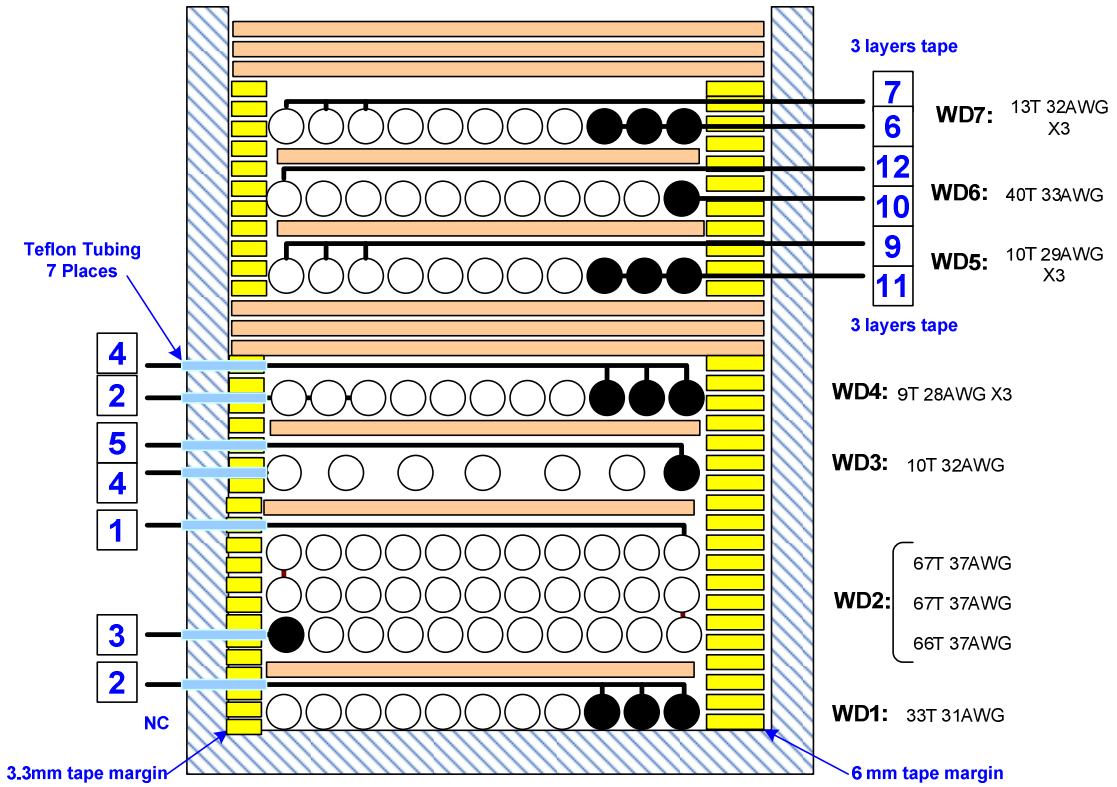

Figure 5 – Transformer Build Diagram.



8 Transformer Spreadsheets

7 Watt (10 W Peak) DVD Application	INPUT	INFO	OUTPUT	UNIT	ACDC_LNK-CV_080508_Rev0-5.xls; LinkSwitch-CV Continuous/Discontinuous Flyback Transformer Design Spreadsheet Customer
ENTER APPLICATION VARIABLES					
VACMIN	85			Volts	Minimum AC Input Voltage
VACMAX	265			Volts	Maximum AC Input Voltage
fL	50			Hertz	AC Mains Frequency
VO	5.00			Volts	Output Voltage
PO	10.00			Watts	Output Power
n	0.68				Efficiency Estimate
Z			0.5		Loss Allocation Factor
tC	3.50		3.5	mSec nds	Bridge Rectifier Conduction Time Estimate
CIN	44.00			uFarads	Input Filter Capacitor

ENTER LinkSwitch-CV VARIABLES					
LinkSwitch-CV	LNK626P			Universal	115 Doubled/230V
<i>Chosen Device</i>		LNK626P	<i>Power Out</i>	10W	17W
ILIMITMIN			0.419	Amps	LinkSwitch-CV Minimum Current Limit
ILIMITMAX			0.482	Amps	LinkSwitch-CV Maximum Current Limit
fS			100000	Hertz	LinkSwitch-CV Switching Frequency
I2FMIN			18225	Hertz	LinkSwitch-CV Min I2F (power Co-efficienct)
I2FMAX			23693	Hertz	LinkSwitch-CV Max I2F (power Co-efficienct)
VOR	110.00		110	Volts	Reflected Output Voltage
VDS			10	Volts	LinkSwitch-CV on-state Drain to Source Voltage
VD			0.5	Volts	Output Winding Diode Forward Voltage Drop
DCON			5.58	us	Output Diode conduction time
KP_TRANSIENT			0.70		Worst case ripple to peak current ratio. Maintain KP_TRANSIENT below 0.25
KP			0.73		Ripple to Peak Current Ratio (0.4<KRP<1.0 : 1.0<KDP<6.0)

ENTER TRANSFORMER CORE/CONSTRUCTION VARIABLES					
Core Type	EEL19			P/N:	PC40EE19/27/5-Z
<i>Core</i>		EEL19		P/N:	*
<i>Bobbin</i>		EEL19_BOBBIN			
AE			0.2454	cm^2	Core Effective Cross Sectional Area
LE			6.185	cm	Core Effective Path Length
AL			720	nH/T^2	Ungapped Core Effective Inductance
BW			19.7	mm	Bobbin Physical Winding Width
M	4.50			mm	Safety Margin Width (Half the Primary to Secondary Creepage Distance)
L	3.00		3		Number of Primary Layers
NS	10.00		10		Number of Secondary Turns

DC INPUT VOLTAGE PARAMETERS					
VMIN			101	Volts	Minimum DC Input Voltage
VMAX			375	Volts	Maximum DC Input Voltage

Bias Winding Parameters					
Add Bias winding	YES				Enter Yes if you want to add a Bias winding
NB					Number of Bias winding turns - AC stacked on Feedback winding

CURRENT WAVEFORM SHAPE PARAMETERS					
DMAX			0.55		Maximum Duty Cycle
IAVG			0.15	Amps	Average Primary Current
IP			0.42	Amps	Minimum Peak Primary Current
IR			0.30	Amps	Primary Ripple Current
IRMS			0.21	Amps	Primary RMS Current

TRANSFORMER PRIMARY DESIGN PARAMETERS				
LPMIN		1465	uHenries	Minimum Primary Inductance
LP_TOL		10		
NP		200		Primary Winding Number of Turns
ALG		37	nH/T^2	Gapped Core Effective Inductance
BM		1438	Gauss	Maximum Flux Density, (BP<3100)
BAC		455	Gauss	AC Flux Density for Core Loss Curves (0.5 X Peak to Peak)
ur		1444		Relative Permeability of Ungapped Core
LG		0.80	mm	Gap Length (Lg > 0.1 mm)
BWE		32.1	mm	Effective Bobbin Width
OD		0.16	mm	Maximum Primary Wire Diameter including insulation
INS		0.04	mm	Estimated Total Insulation Thickness (= 2 * film thickness)
DIA		0.12	mm	Bare conductor diameter
AWG		37	AWG	Primary Wire Gauge (Rounded to next smaller standard AWG value)
CM		20	Cmils	Bare conductor effective area in circular mils
CMA	<i>Warning</i>	97	Cmils/Amp	!!! INCREASE CMA>200 (increase L(primary layers),decrease NS,larger Core)

TRANSFORMER SECONDARY DESIGN PARAMETERS				
Lumped parameters				
ISP		8.38	Amps	Peak Secondary Current
ISRMS		3.77	Amps	Secondary RMS Current
IO		2.00	Amps	Power Supply Output Current
IRIPPLE		3.20	Amps	Output Capacitor RMS Ripple Current
CMS		755	Cmils	Secondary Bare Conductor minimum circular mils
AWGS		21	AWG	Secondary Wire Gauge (Rounded up to next larger standard AWG value)
DIAS		0.73	mm	Secondary Minimum Bare Conductor Diameter
ODS		1.07	mm	Secondary Maximum Outside Diameter for Triple Insulated Wire
INSS		0.17	mm	Maximum Secondary Insulation Wall Thickness

VOLTAGE STRESS PARAMETERS				
VDRAIN		626	Volts	Maximum Drain Voltage Estimate (Includes Effect of Leakage Inductance)
PIVS		24	Volts	Output Rectifier Maximum Peak Inverse Voltage

FEEDBACK VARIABLES				
NFB		9.00		Feedback winding number of turns
RUPPER		9.05	k-ohms	Upper resistor of feedback network
RLOWER		6.13	k-ohms	Lower resistor of feedback network

TRANSFORMER SECONDARY DESIGN PARAMETERS (MULTIPLE OUTPUTS)				
1st output				
VO1	5.00	5	Volts	Output Voltage (if unused, defaults to single output design)
IO1	1.70	1.700	Amps	Output DC Current
PO1		8.50	Watts	Output Power
VD1		0.5	Volts	Output Diode Forward Voltage Drop
NS1		10.00		Output Winding Number of Turns
ISRMS1		3.207	Amps	Output Winding RMS Current
IRIPPLE1		2.72	Amps	Output Capacitor RMS Ripple Current
PIVS1		24	Volts	Output Rectifier Maximum Peak Inverse Voltage
CMS1		641	Cmils	Output Winding Bare Conductor minimum circular mils
AWGS1		22	AWG	Wire Gauge (Rounded up to next larger standard AWG value)
DIAS1		0.65	mm	Minimum Bare Conductor Diameter



ODS1	1.07	mm	Maximum Outside Diameter for Triple Insulated Wire
------	------	----	--

2nd output

VO2	12.00	Volts	Output Voltage
IO2	0.10	Amps	Output DC Current
PO2	1.20	Watts	Output Power
VD2	0.7	Volts	Output Diode Forward Voltage Drop
NS2	23.09		Output Winding Number of Turns
ISRMS2	0.189	Amps	Output Winding RMS Current
IRIPPLE2	0.16	Amps	Output Capacitor RMS Ripple Current
PIVS2	55	Volts	Output Rectifier Maximum Peak Inverse Voltage
CMS2	38	Cmils	Output Winding Bare Conductor minimum circular mils
AWGS2	34	AWG	Wire Gauge (Rounded up to next larger standard AWG value)
DIAS2	0.16	mm	Minimum Bare Conductor Diameter
ODS2	0.46	mm	Maximum Outside Diameter for Triple Insulated Wire

3rd output

VO3	22.00	Volts	Output Voltage
IO3	0.02	Amps	Output DC Current
PO3	0.33	Watts	Output Power
VD3	0.7	Volts	Output Diode Forward Voltage Drop
NS3	41.27		Output Winding Number of Turns
ISRMS3	0.028	Amps	Output Winding RMS Current
IRIPPLE3	0.02	Amps	Output Capacitor RMS Ripple Current
PIVS3	99	Volts	Output Rectifier Maximum Peak Inverse Voltage
CMS3	6	Cmils	Output Winding Bare Conductor minimum circular mils
AWGS3	42	AWG	Wire Gauge (Rounded up to next larger standard AWG value)
DIAS3	0.06	mm	Minimum Bare Conductor Diameter
ODS3	0.26	mm	Maximum Outside Diameter for Triple Insulated Wire
Total power	10.03	Watts	Total Output Power
Negative Output	3	3	Output # 3 is negative output

Notes:

- Primary winding CMA warning is allowed because this occurs during peak loading. CMA is higher under normal operation.
- Rupper and Rlower values may be different in the actual assembly due to tuning of output voltages.
- The -22 V winding turns was adjusted from 41 to 40 turns to center the output voltage.
- The transformer was designed with a flux density below 1500 Gauss (150 mT) to reduce audible noise generation from the transformer. A flux density around this level is recommended when using long cores (EEL vs EE). Higher flux densities are possible for EE cores or with EEL cores where higher levels of audible noise are acceptable.

9 Performance Data

All measurements performed at room temperature, 60 Hz input frequency.

9.1 Efficiency

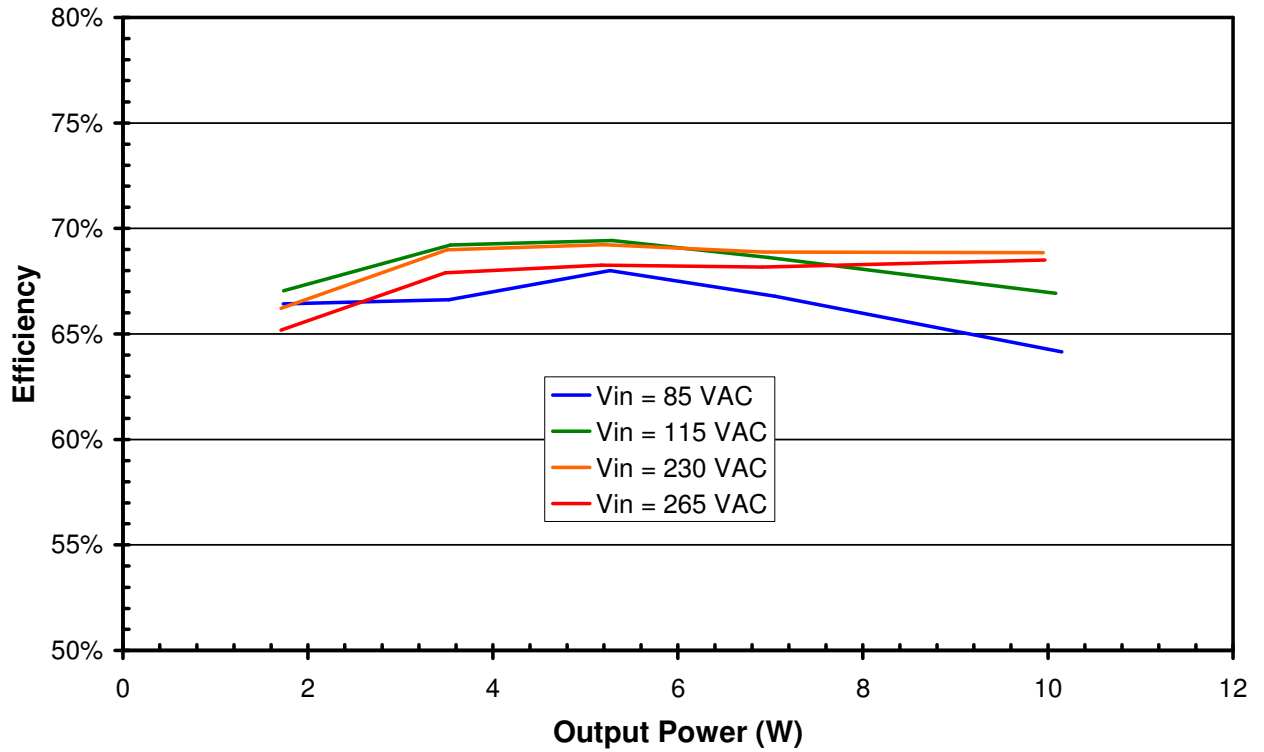

Figure 6 – Efficiency vs. Input Voltage, Room Temperature, 60 Hz.



No-load Input Power

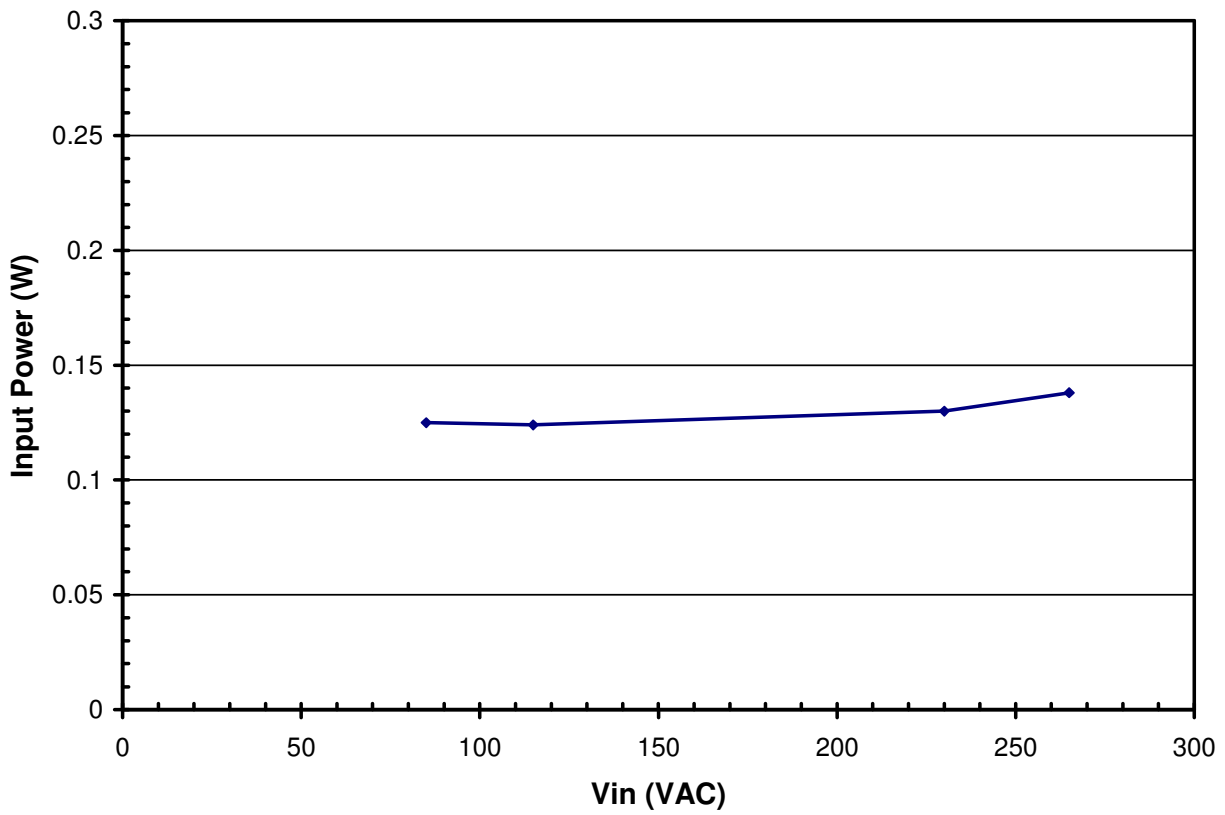

Figure 7 – Zero Load Input Power vs. Input Line Voltage, Room Temperature, 60 Hz.



9.2 Available Standby Output Power

The chart below shows the available output power vs line voltage for an input power of 1 W, 0.5 W and 0.3 W.

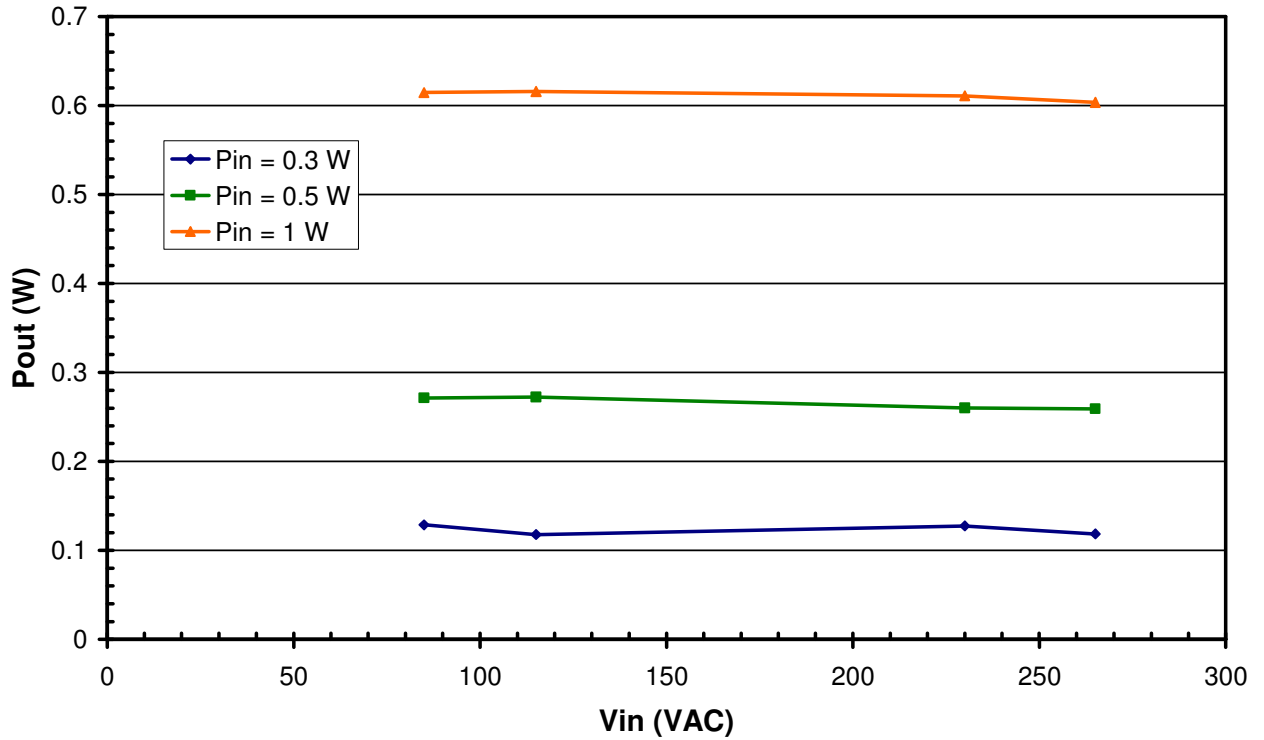

Figure 8 – Available Standby Power.

9.3 Regulation

9.3.1 Load Regulation

The 5 Volt output current was varied from 0.05 Amp to 1.75 Amps. The +12 V current was constant at 0.1 Amp and the -22 V current was constant at 15 mA.

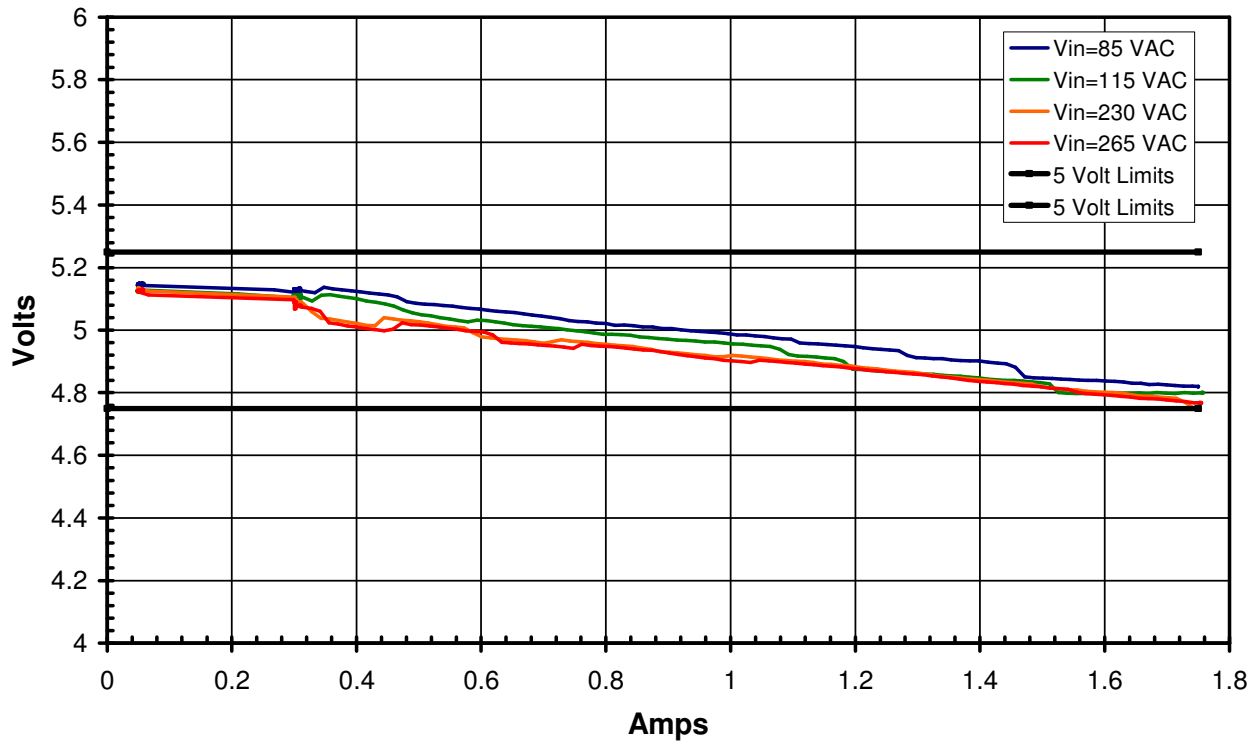

Figure 9 – Load Regulation, Room Temperature.



9.3.2 Cross Regulation

The figures below show the output voltage vs. total output power. The charts show the voltage variations as the loads vary for all legal load combinations. The 5 V current varied from 50 mA to 1.75 Amps. The 12 V output current varied from 50 mA to 100 mA. The -22 V output current varied from 5 mA to 15 mA.

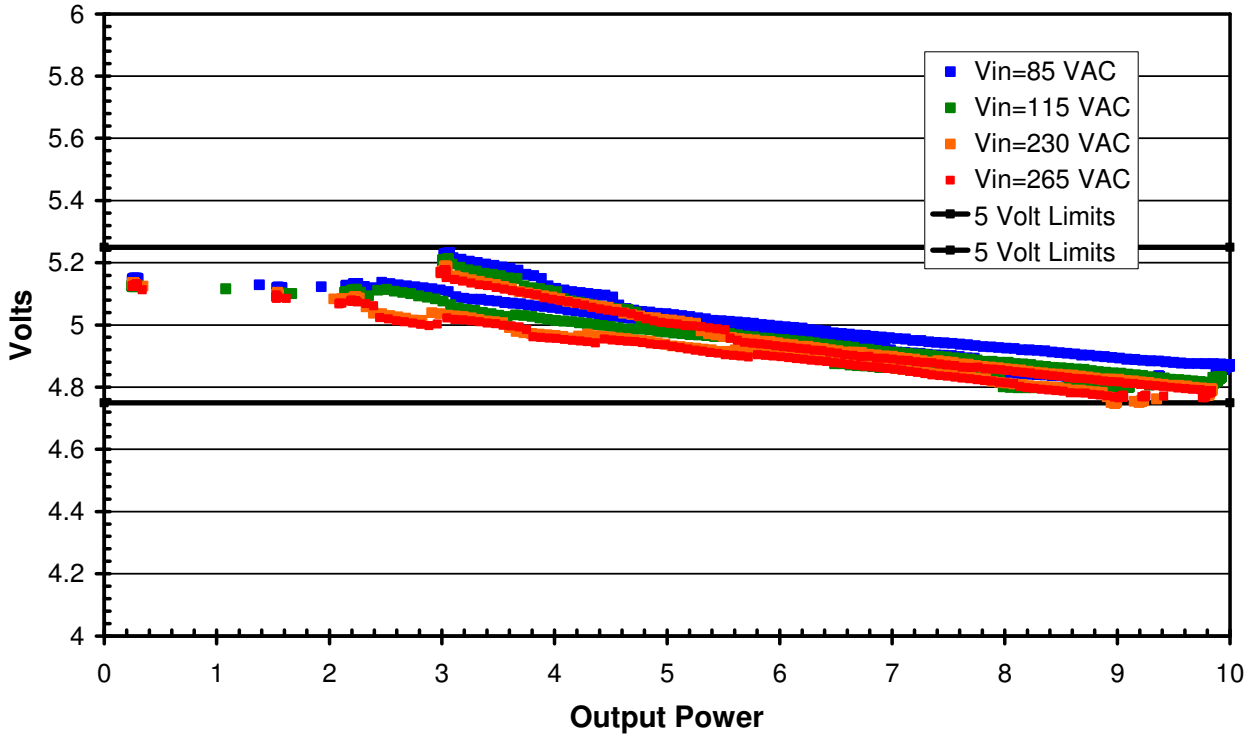

Figure 10 – 5 V Cross Regulation, Room Temperature.

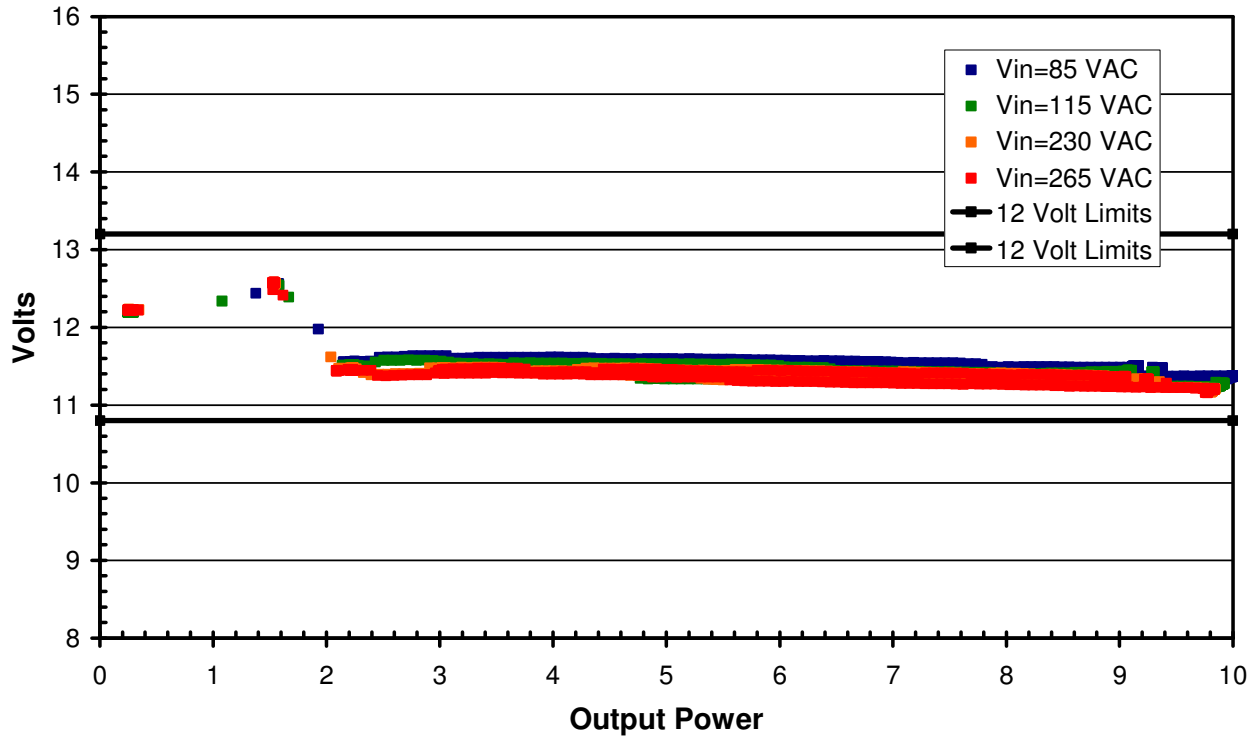

Figure 11 – 12 V Cross Regulation, Room Temperature.

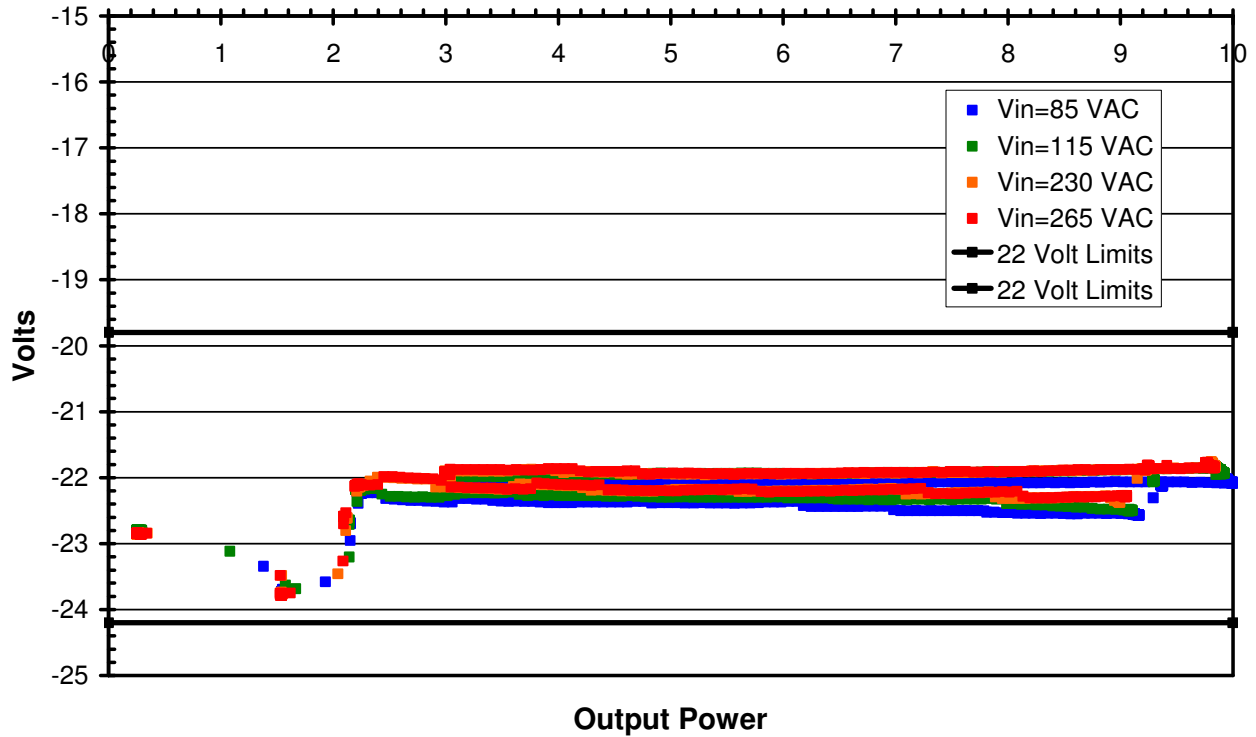

Figure 12 – 22 V Cross Regulation, Room Temperature.

The graphs below show the output Voltage and load currents required to power a DVD player. The graphs represent the current demand as the DVD player is exercised in all operating modes. The Model used was a Philips DVP 5990.

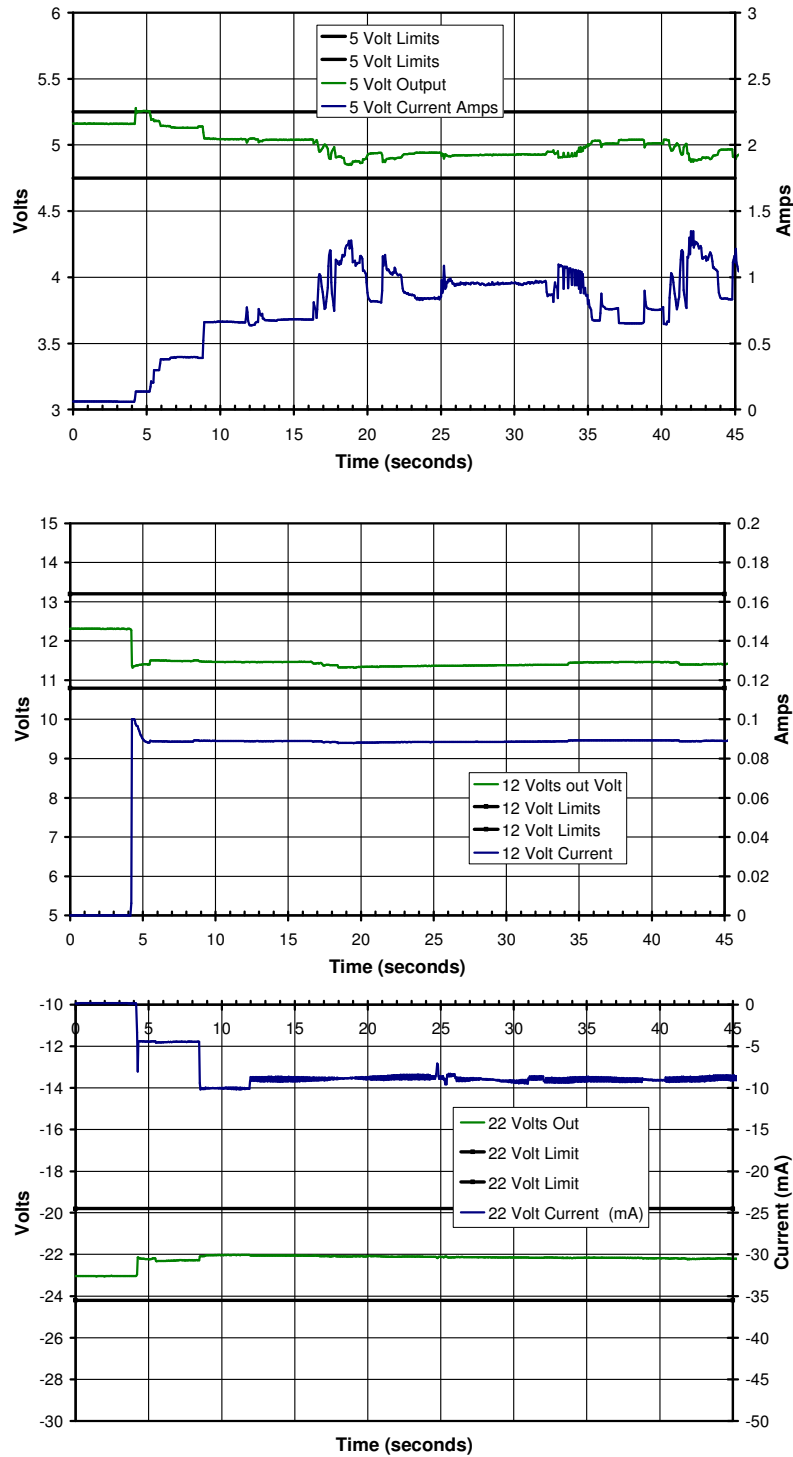

Figure 13 – Voltage Regulation and Current Demands in DVD Application.



10 Thermal Performance

The power supply was placed inside a cardboard box (no air flow) in the temperature chamber. The loads are as follows:

5 V at 1 Amp
 12 V at 0.1 Amp
 -22 V at 15 mA

This load represents a typical DVD player Load during Play Mode. The ambient temperature was measured inside the cardboard box.

Item	Temperature Deg C			
	85 VAC	115 VAC	230 VAC	265 VAC
Ambient	40	40	40	40
Clamp Zener (VR1)	88.9	84.8	82.7	83.0
LNK626 (U1)	68.0	65.1	66.4	65.0



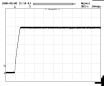

11 Waveforms

11.1 Drain Voltage and Current, Normal Operation

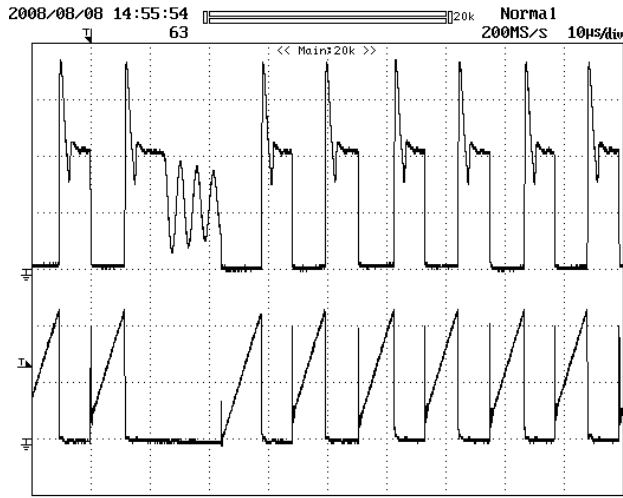

Figure 14 – 85 VAC, Full Load (10 W).
Upper: V_{DRAIN} , 100 V, 10 μ s / div.
Lower: I_{DRAIN} , 0.2 A / div.

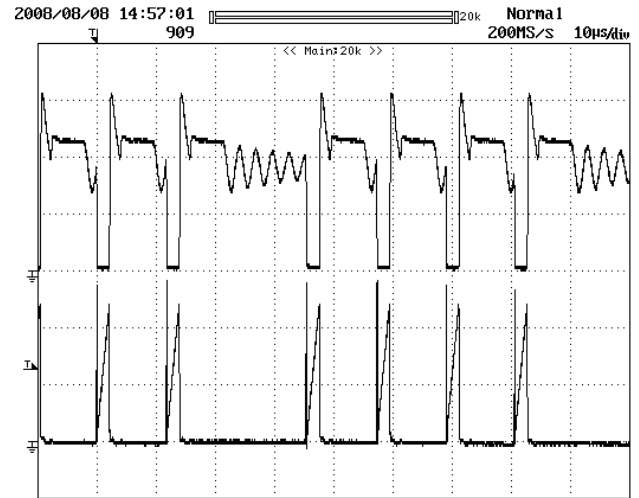

Figure 15 – 265 VAC, Full Load (10 W).
Upper: V_{DRAIN} , 200 V, 10 μ s / div.
Lower: I_{DRAIN} , 0.2 A / div.

11.2 Output Voltage Start-up Profile

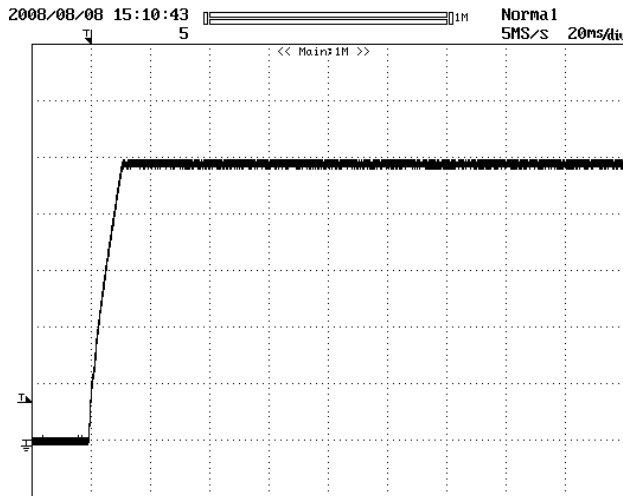

Figure 16 – 5 V Start-up Profile, 115 VAC
1 V, 20 ms / div.

Figure 17 – 5 V Start-up Profile, 230 VAC
1 V, 20 ms / div.



11.3 Drain Voltage and Current Start-up Profile

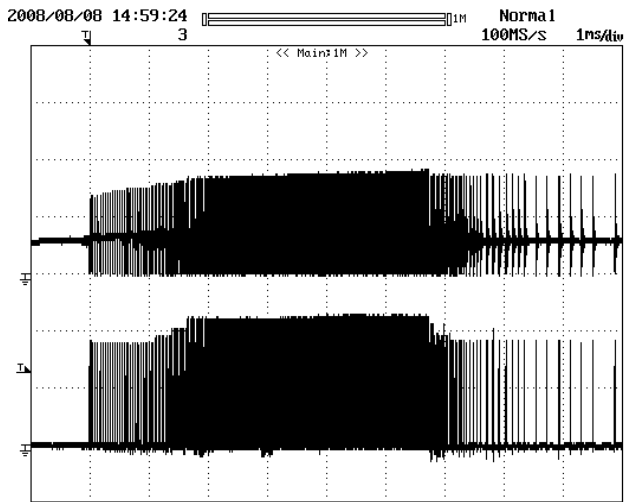

Figure 18 – 85 VAC Input and Maximum Load.
Upper: V_{DRAIN} , 200 V, 1 ms / div.
Lower: I_{DRAIN} , 0.2 A / div.

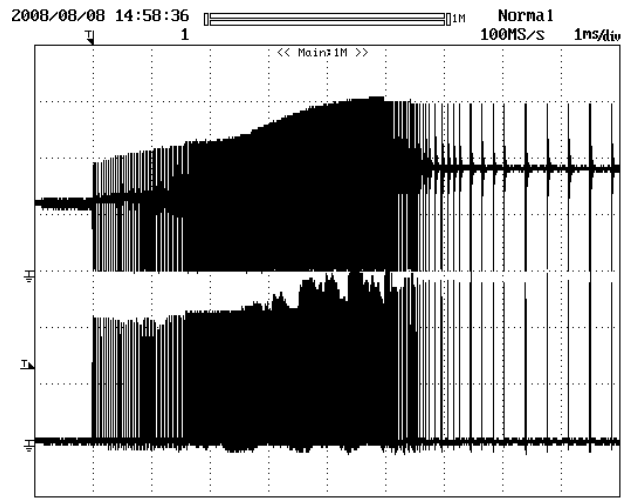

Figure 19 – 265 VAC Input and Maximum Load.
Upper: V_{DRAIN} , 200 V, 1 ms / div.
Lower: I_{DRAIN} , 0.2 A / div.

11.4 Load Transient Response (50% to 100% Load Step)

In the figures shown below, signal averaging was used to better enable viewing the load transient response. The oscilloscope was triggered using the load current step as a trigger source. Since the output switching and line frequency occur essentially at random with respect to the load transient, contributions to the output ripple from these sources will average out, leaving the contribution only from the load step response.

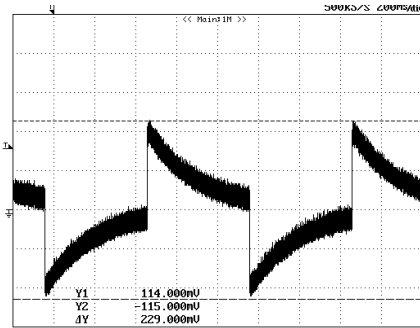

Figure 20 – Transient Response, 115 VAC, 5 V Load Step: 0.55 A – 1.10 A -0.55 A
5 V Output
50 mV, 200 ms / div.

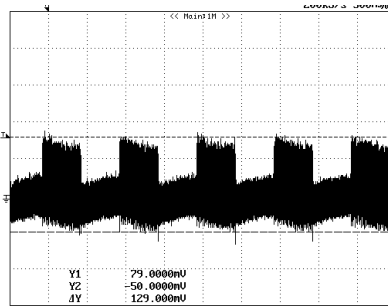

Figure 21 – Transient Response, 115 VAC, 12 V Output Response During 5 V Transient.
50 mV, 200 ms/div.

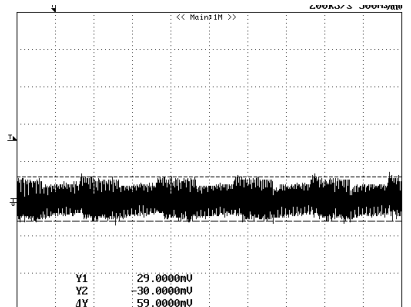

Figure 22 – Transient Response, 115 VAC, -22 V Output Response During 5 V Transient.
50 mV, 200 ms/div.

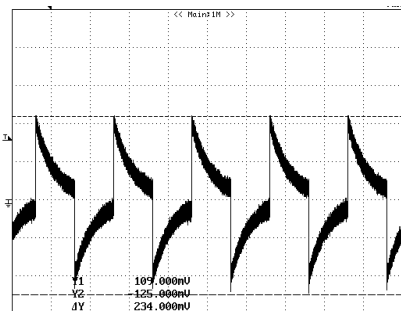

Figure 23 – Transient Response, 230 VAC, 5 V Load Step: 0.55 A – 1.10 A -0.55 A
5 V Output
50 mV, 200 ms / div.

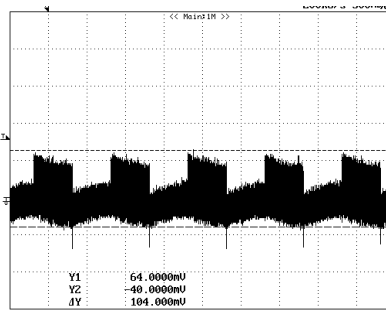

Figure 24 – Transient Response, 230 VAC, 12 V Output Response During 5 V Transient.
50 mV, 200 ms / div.

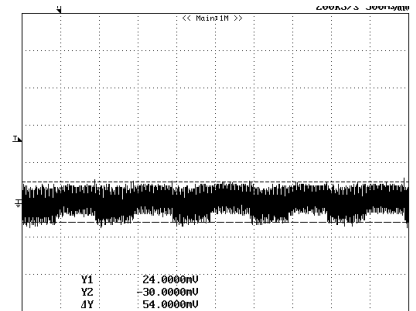

Figure 25 – Transient Response, 230 VAC, -22 V Output Response During 5 V Transient.
50 mV, 200 ms / div.



11.5 Output Ripple Measurements

11.5.1 Ripple Measurement Technique

For DC output ripple measurements, use a modified oscilloscope test probe to reduce spurious signals. Details of the probe modification are provided in the figures below.

Tie two capacitors in parallel across the probe tip of the 4987BA probe adapter. Use a $0.1\ \mu\text{F}/50\ \text{V}$ ceramic capacitor and a $1.0\ \mu\text{F}/50\ \text{V}$ aluminum-electrolytic capacitor. The aluminum-electrolytic capacitor is polarized, so always maintain proper polarity across DC outputs.

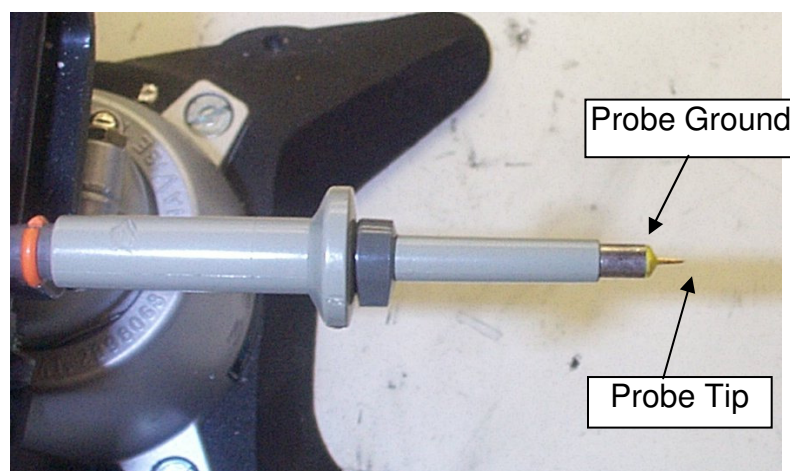

Figure 26 – Oscilloscope Probe Prepared for Ripple Measurement. (End Cap and Ground Lead Removed)

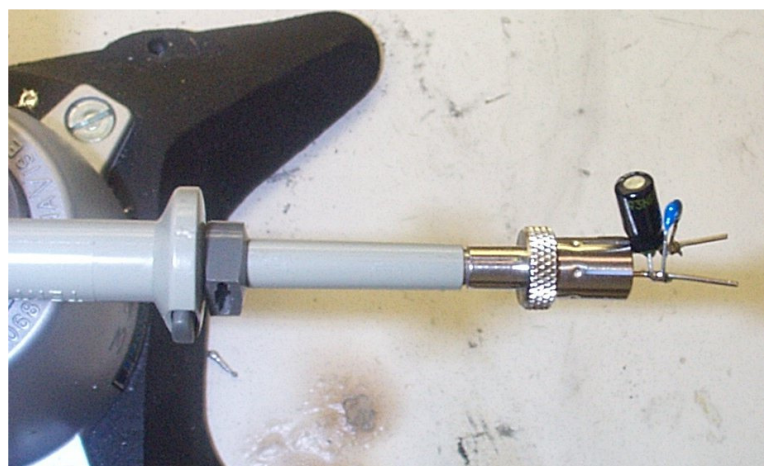

Figure 27 – Oscilloscope Probe with Probe Master (www.probemaster.com) 4987A BNC Adapter. (Modified with wires for ripple measurement, and two parallel decoupling capacitors added)

11.5.2 Measurement Results

Unless otherwise specified, full load is: 5 Volts @ 1.10 A
 12 Volts @ 0.10 A
 -22 Volts @ 0.015 A

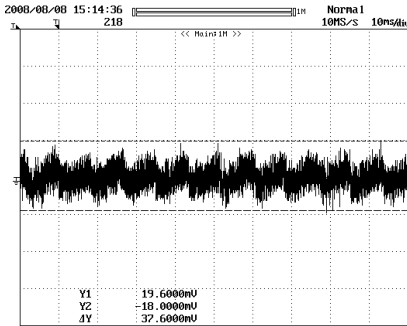

Figure 28 – 5 V Ripple, 85 VAC, Full Load (7W)
 10 ms, 20 mV / div.
 Ripple: 38 mVp-p.

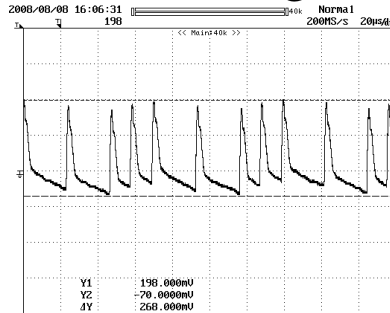

Figure 29 – 12 V Ripple, 85 VAC, Full Load.
 10 μ s, 100 mV / div.
 Ripple: 268 mVp-p.

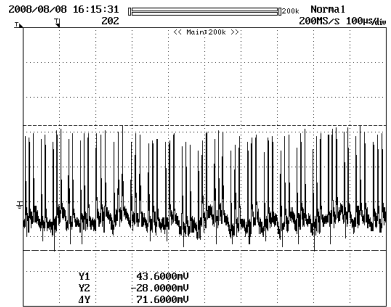

Figure 30 – -22 V Ripple, 85 VAC, Full Load.
 100 μ s, 20 mV / div.
 Ripple: 72 mVp-p.

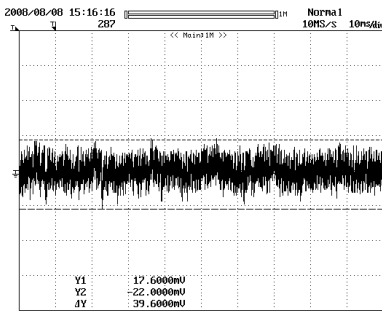

Figure 31 – 5 V Ripple, 115 VAC, Full Load (7 W).
 10 ms, 20 mV / div.
 Ripple: 40 mVp-p.

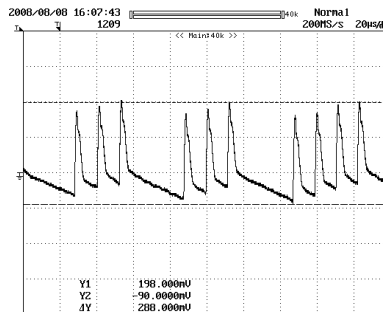

Figure 32 – 12 V Ripple, 115 VAC, Full Load.
 20 μ s, 100 mV / div.
 Ripple: 288 mVp-p.

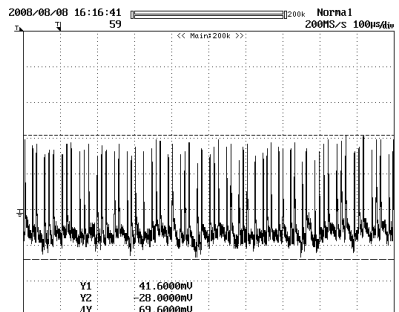

Figure 33 – -22 V Ripple, 115 VAC, Full Load.
 100 μ s, 20 mV / div.
 Ripple: 70 mVp-p.

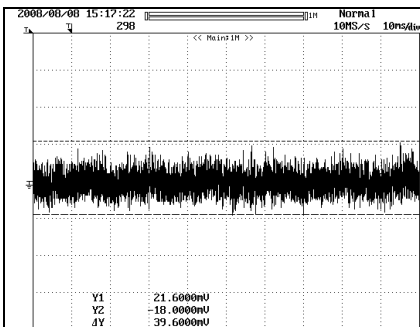

Figure 34 – 5 V Ripple, 230 VAC, Full Load (7W).
 10 ms, 20 mV / div.
 Ripple: 40 mVp-p.

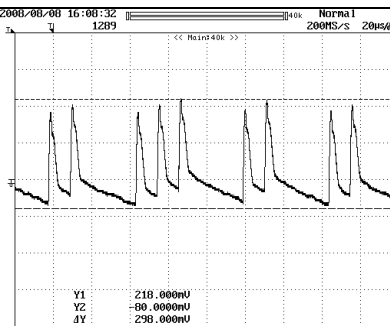

Figure 35 – 12 V Ripple, 230 VAC, Full Load.
 20 μ s, 100 mV / div.
 Ripple: 258 mVp-p.

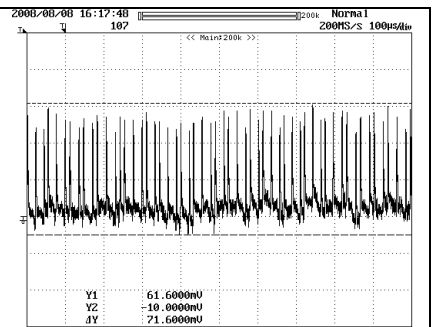
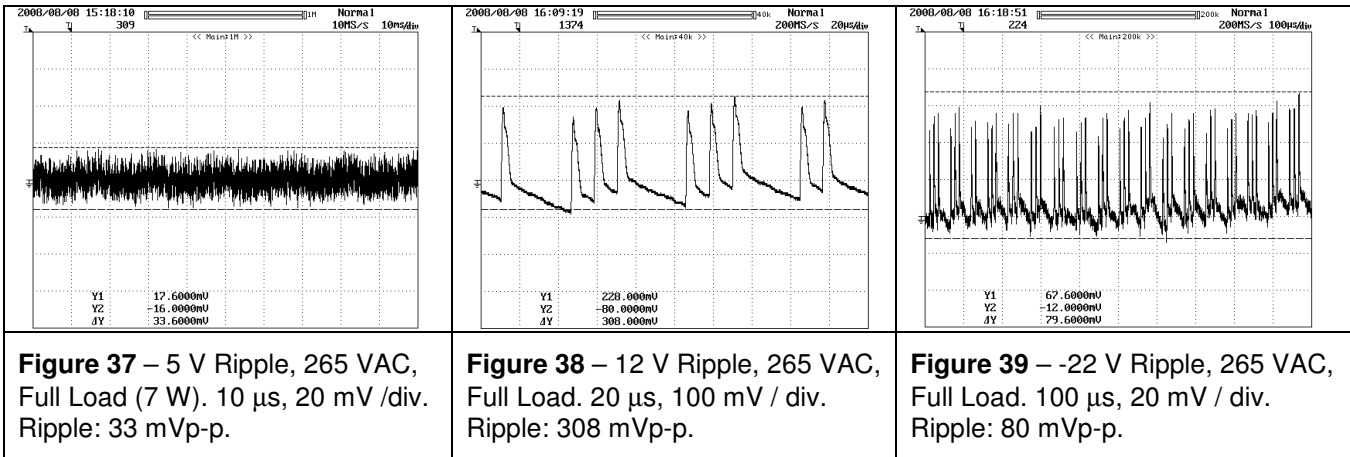

Figure 36 – -22 V Ripple, 230 VAC, Full Load.
 100 μ s, 20 mV / div.
 Ripple: 72 mVp-p.



12 Line Surge

Differential input line 1.2/50 μ s surge testing was completed on a single test unit to IEC61000-4-5. Input voltage was set at 230 VAC / 60 Hz. Output was loaded at full load and operation was verified following each surge event.

Surge Level (V)	Generator Output Impedance (Ω)	Input Voltage (VAC)	Injection Location	Injection Phase ($^\circ$)	Test Result (Pass/Fail)
+2000	12	230	L to N	90	Pass
-2000	12	230	L to N	270	Pass
+2000	2	230	L to N	90	Pass
-2000	2	230	L to N	270	Pass
+6000 ring wave	12	230	L1/L2 - PE	90	Pass
-6000 ring wave	12	230	L1/L2 - PE	270	Pass
+6000	2	230	L1/L2 - PE	90	Pass
-6000	2	230	L,N to Output RTN	270	Pass

Unit passes under all test conditions.



13 Conducted EMI

Conducted EMI was measured with the power supply operating a DVD Player. Six plots show the conducted EMI for 115 VAC and 230 VAC and with the player in Standby Mode, On Mode (no disk in payer) and Play Mode. The DVD player chassis was not grounded for these measurements. Other testing configurations may require a Y capacitor to meet EMI requirements.

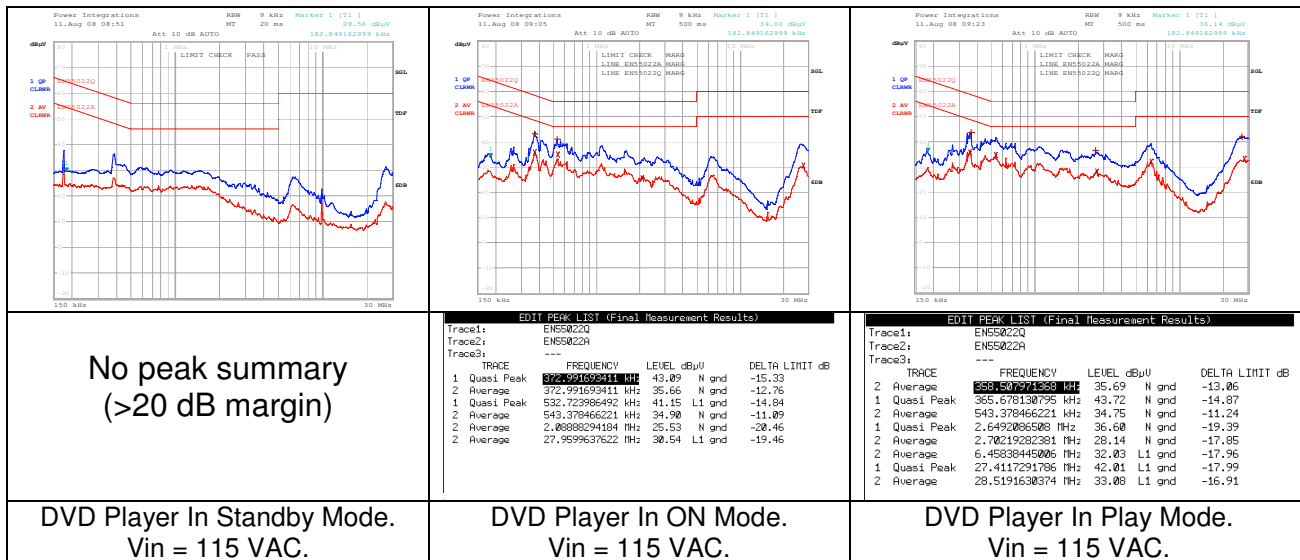

Figure 43 – Conducted EMI, Maximum Steady State Load, 115 VAC, 60 Hz, and EN55022 B Limits.

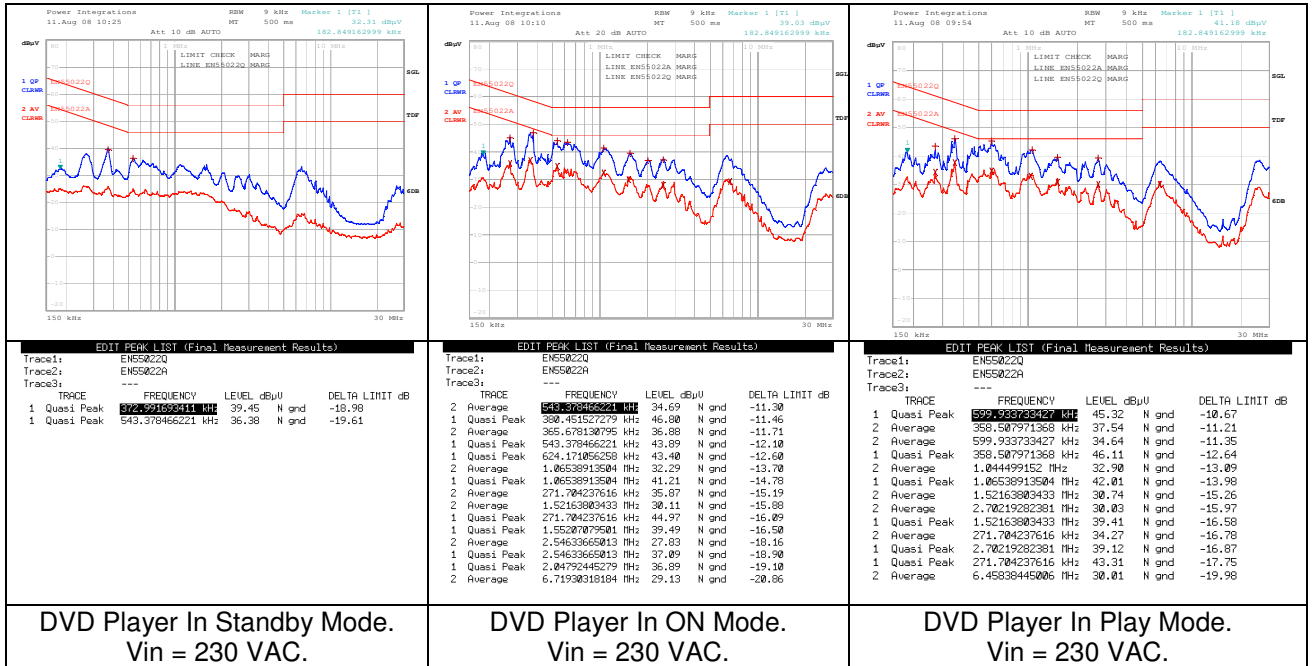

Figure 44 – Conducted EMI, Maximum Steady State Load, 230 VAC, 60 Hz, and EN55022 B Limits.

14 Audible Noise

The power supply's audible noise was measured while operating a DVD Player. With the case removed the microphone was placed 2 cm directly above the transformer. Measurements were made with a calibrated microphone and Audio Precision System II audio analyzer. Audio levels below 35 dBA measured in this way are considered inaudible when the case is fitted.

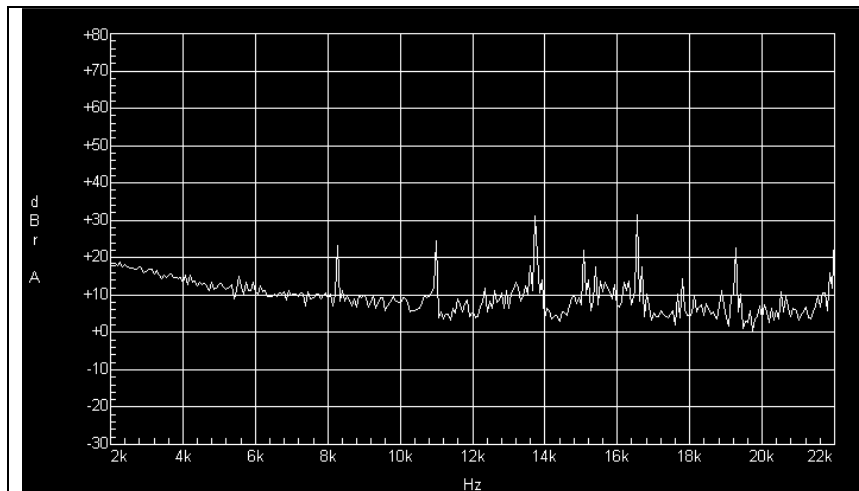

Figure 45 – DVD Player in Standby Mode.
 $V_{in} = 115 \text{ VAC}$.

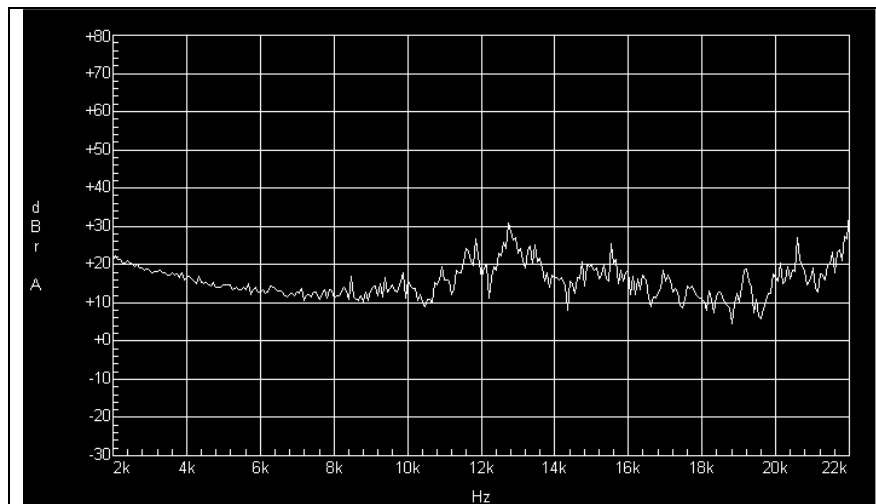
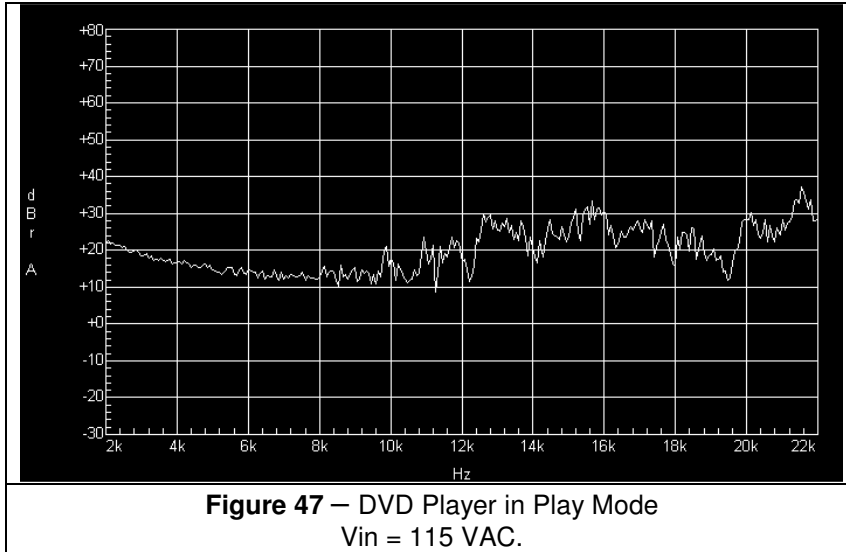

Figure 46 – DVD Player in On Mode.
 $V_{in} = 115 \text{ VAC}$.



Revision History

Date	Author	Revision	Description & changes	Reviewed
11-Nov-08	JAC	1.0	Initial Release	PV



Notes



Notes



Notes



For the latest updates, visit our website: www.powerint.com

Power Integrations reserves the right to make changes to its products at any time to improve reliability or manufacturability. Power Integrations does not assume any liability arising from the use of any device or circuit described herein. POWER INTEGRATIONS MAKES NO WARRANTY HEREIN AND SPECIFICALLY DISCLAIMS ALL WARRANTIES INCLUDING, WITHOUT LIMITATION, THE IMPLIED WARRANTIES OF MERCHANTABILITY, FITNESS FOR A PARTICULAR PURPOSE, AND NON-INFRINGEMENT OF THIRD PARTY RIGHTS.

PATENT INFORMATION

The products and applications illustrated herein (including transformer construction and circuits external to the products) may be covered by one or more U.S. and foreign patents, or potentially by pending U.S. and foreign patent applications assigned to Power Integrations. A complete list of Power Integrations' patents may be found at www.powerint.com. Power Integrations grants its customers a license under certain patent rights as set forth at <http://www.powerint.com/ip.htm>.

The PI Logo, TOPSwitch, TinySwitch, LinkSwitch, DPA-Switch, PeakSwitch, EcoSmart, Clampless, E-Shield, Filterfuse, StackFET, PI Expert and PI FACTS are trademarks of Power Integrations, Inc. Other trademarks are property of their respective companies. ©Copyright 2008 Power Integrations, Inc.

Power Integrations Worldwide Sales Support Locations

WORLD HEADQUARTERS

5245 Hellyer Avenue
San Jose, CA 95138, USA.
Main: +1-408-414-9200
Customer Service:
Phone: +1-408-414-9665
Fax: +1-408-414-9765
e-mail: usasales@powerint.com

GERMANY

Rueckertstrasse 3
D-80336, Munich
Germany
Phone: +49-89-5527-3911
Fax: +49-89-5527-3920
e-mail: eurosales@powerint.com

JAPAN

Kosei Dai-3 Bldg.,
2-12-11, Shin-Yokohama,
Kohoku-ku, Yokohama-shi,
Kanagawa 222-0033
Phone: +81-45-471-1021
Fax: +81-45-471-3717
e-mail: japansales@powerint.com

TAIWAN

5F, No. 318, Nei Hu Rd., Sec. 1
Nei Hu Dist.
Taipei, Taiwan 114, R.O.C.
Phone: +886-2-2659-4570
Fax: +886-2-2659-4550
e-mail: taiwansales@powerint.com

CHINA (SHANGHAI)

Rm 1601/1610, Tower 1,
Kerry Everbright City
No. 218 Tianmu Road West,
Shanghai, P.R.C. 200070
Phone: +86-21-6354-6323
Fax: +86-21-6354-6325
e-mail: chinasales@powerint.com

INDIA

#1, 14th Main Road
Vasanthanagar
Bangalore-560052 India
Phone: +91-80-41138020
Fax: +91-80-41138023
e-mail: indiasales@powerint.com

KOREA

RM 602, 6FL
Korea City Air Terminal B/D,
159-6
Samsung-Dong, Kangnam-
Gu,
Seoul, 135-728, Korea
Phone: +82-2-2016-6610
Fax: +82-2-2016-6630
e-mail: koreasales@powerint.com

UNITED KINGDOM

1st Floor, St. James's House
East Street, Farnham
Surrey, GU9 7TJ
United Kingdom
Phone: +44 (0) 1252-730-141
Fax: +44 (0) 1252-727-689
e-mail: eurosales@powerint.com

CHINA (SHENZHEN)

Rm A, B & C 4th Floor, Block C,
Electronics Science and
Technology Building, 2070
Shennan Zhong Rd,
Shenzhen, Guangdong,
China, 518031
Phone: +86-755-8379-3243
Fax: +86-755-8379-5828
e-mail: chinasales@powerint.com

ITALY

Via De Amicis 2
20091 Bresso MI – Italy
Phone: +39-028-928-6000
Fax: +39-028-928-6009
e-mail: eurosales@powerint.com

SINGAPORE

51 Newton Road,
#15-08/10 Goldhill Plaza,
Singapore, 308900
Phone: +65-6358-2160
Fax: +65-6358-2015
e-mail: singaporesales@powerint.com

APPLICATIONS HOTLINE

World Wide +1-408-414-9660

APPLICATIONS FAX

World Wide +1-408-414-9760

