



Design Example Report

Title	<i>Slim 36.3 W Power Supply Using TOPSwitch™-JX TOP267VG</i>
Specification	90 VAC – 264 VAC Input; 5 V, 1.5 A, and 16 V, 1.8 A Outputs
Application	LCD Monitor
Author	Applications Engineering Department
Document Number	DER-259
Date	August 18, 2010
Revision	1.0

Summary and Features

- Low profile <12 mm component height
- Very low standby consumption
 - <100 mW input power with 6 mA load on 5 V output at 230 VAC input
 - <90 mW input power with 5 mA load on 5 V output at 230 VAC input
- Very low no-load input power
 - No-load Input power of 55 mW at 230 VAC input
- High full-load efficiency
 - >82% efficiency at 90 VAC / 60 Hz
- Low TOPSwitch-JX device temperature
 - <92°C at 90 VAC, 60 Hz, 25°C
 - <100°C at 90 VAC, 60 Hz, 40°C
- >12 dB margin on conducted EMI
- Hysteretic output overvoltage protection
- Hysteretic output short-circuit protection
- Hysteretic thermal overload protection with large hysteresis prevents board temperatures >100°C

PATENT INFORMATION

The products and applications illustrated herein (including transformer construction and circuits external to the products) may be covered by one or more U.S. and foreign patents, or potentially by pending U.S. and foreign patent applications assigned to Power Integrations. A complete list of Power Integrations' patents may be found at www.powerint.com. Power Integrations grants its customers a license under certain patent rights as set forth at <http://www.powerint.com/ip.htm>.

Power Integrations

5245 Hellyer Avenue, San Jose, CA 95138 USA.

Tel: +1 408 414 9200 Fax: +1 408 414 9201

www.powerint.com

Table of Contents

1	Introduction.....	4
2	Power Supply Specification	5
3	Schematic.....	6
4	Circuit Description	7
4.1	Input EMI Filtering and Rectification.....	7
4.2	TOPSwitch-JX Primary.....	7
4.3	Output Rectification	7
4.4	Output Feedback.....	8
5	PCB Layout	9
6	Bill of Materials	10
7	Transformer Specification.....	12
7.1	Electrical Diagram	12
7.2	Electrical Specifications.....	12
7.3	Materials.....	12
7.4	Transformer Build Diagram	13
7.5	Transformer Construction.....	13
8	Transformer Design Spreadsheet.....	15
9	Performance Data	19
9.1	Full Load Efficiency	19
9.2	Input Power with 5 mA and 6 mA Load at 5 V Output	20
9.3	No-load Input Power.....	21
9.4	Regulation	22
9.4.1	Load	22
9.4.2	Line	24
9.4.3	Cross Regulation.....	25
10	Thermal Performance	26
10.1	Thermal Performance at Room Temperature.....	26
10.2	Thermal Performance at 40°C Ambient Temperature	27
11	Waveforms.....	28
11.1	Drain Voltage and Current, Normal Operation.....	28
11.2	Output Voltage Start-up Profile.....	28
11.3	Drain Voltage and Current Start-up Profile.....	29
11.4	Load Transient Response (75% to 100% Load Step)	29
11.5	Output Overvoltage Protection	31
11.6	Output Ripple Measurements.....	32
11.6.1	Ripple Measurement Technique	32
11.6.2	Measurement Results	33
12	Control Loop Measurements.....	34
12.1	90 VAC 60 Hz Maximum Load	34
12.2	115 VAC 60 Hz Maximum Load	35
12.3	230 VAC 50 Hz Maximum Load	36
12.4	264 VAC 50 Hz Maximum Load	37
13	Conducted EMI	38
14	Revision History	40



Important Note:

Although this board is designed to satisfy safety isolation requirements, the engineering prototype has not been agency approved. Therefore, all testing should be performed using an isolation transformer to provide the AC input to the prototype board.



1 Introduction

This document is an engineering report describing a 2-output (5 V, 1.5 A and 16 V, 1.8 A) power supply utilizing a TOP267VG. The TOP267VG is part of the TOPSwitch-JX IC family from Power Integrations.

The document contains the power supply specification, schematic, bill of materials, transformer documentation, printed circuit layout, and performance data.

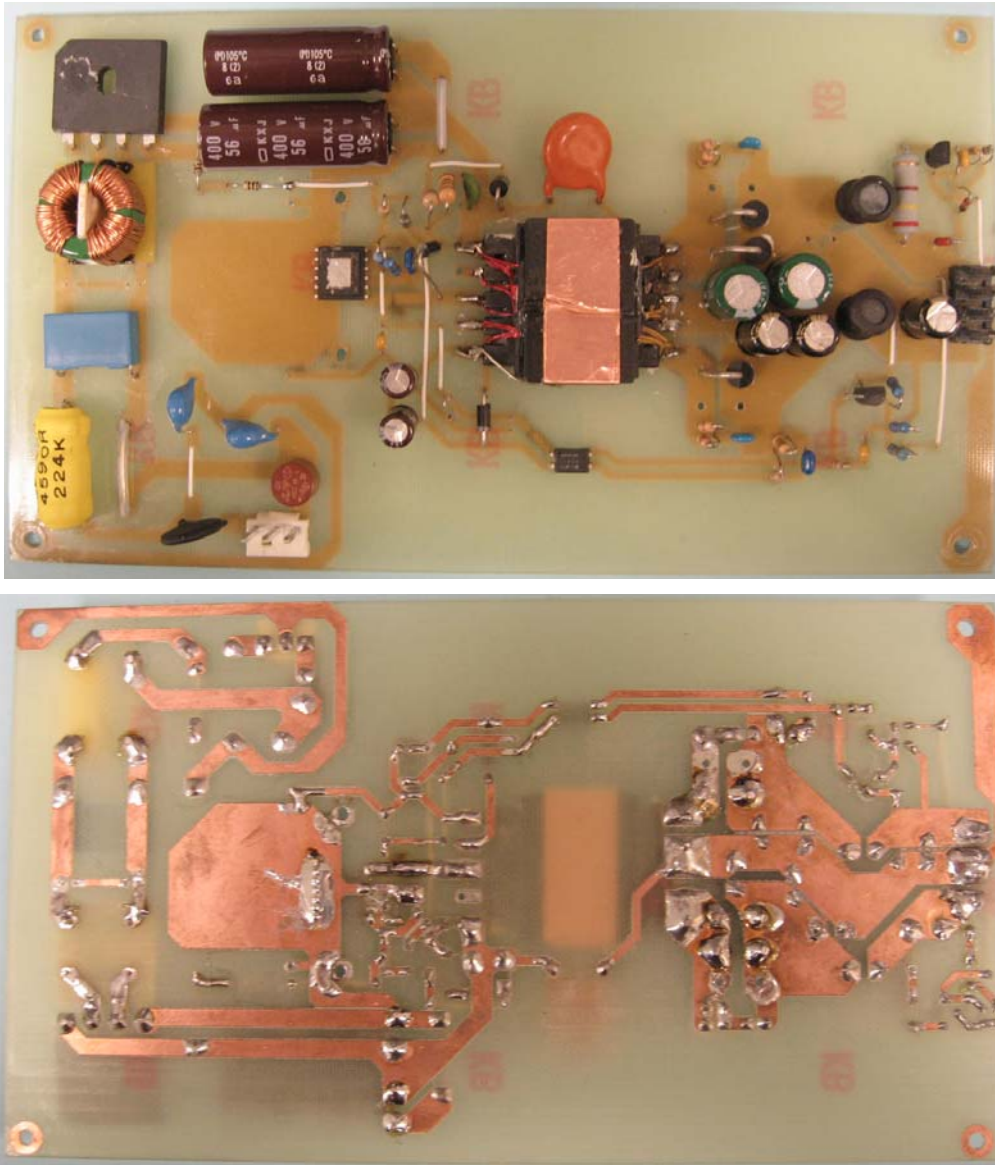

Figure 1 – Populated Board.



2 Power Supply Specification

The table below represents the minimum acceptable performance of the design. Actual performance is listed in the results section.

Description	Symbol	Min	Typ	Max	Units	Comment
Input						
Voltage	V_{IN}	90		264	VAC	3 Wire – with P.E.
Frequency	f_{LINE}	47	50/60	64	Hz	
No-load Input Power (264 VAC)				<0.1	W	With 5 mA load on 5 V output
Output						
Output Voltage 1	V_{OUT1}	4.75	5	5.25	V	± 5%
Output Ripple Voltage 1	$V_{RIPPLE1}$			50	mV	
Output Current 1	I_{OUT1}	0		1.5	A	
Output Voltage 2	V_{OUT2}	13.6	16	18.4	V	± 15%
Output Ripple Voltage 2	$V_{RIPPLE2}$			500	mV	20 MHz bandwidth
Output Current 2	I_{OUT2}	0		1.8	A	
Total Output Power						
Continuous Output Power	P_{OUT}			36.3	W	
Efficiency						
Full Load (90 VAC)	η	81			%	Measured at P_{OUT} 25 °C
Environmental						
Conducted EMI						Meets CISPR22B / EN55022B
Safety						Designed to meet IEC950, UL1950 Class II
Ambient Temperature	T_{AMB}	0		40	°C	Free convection, sea level



3 Schematic

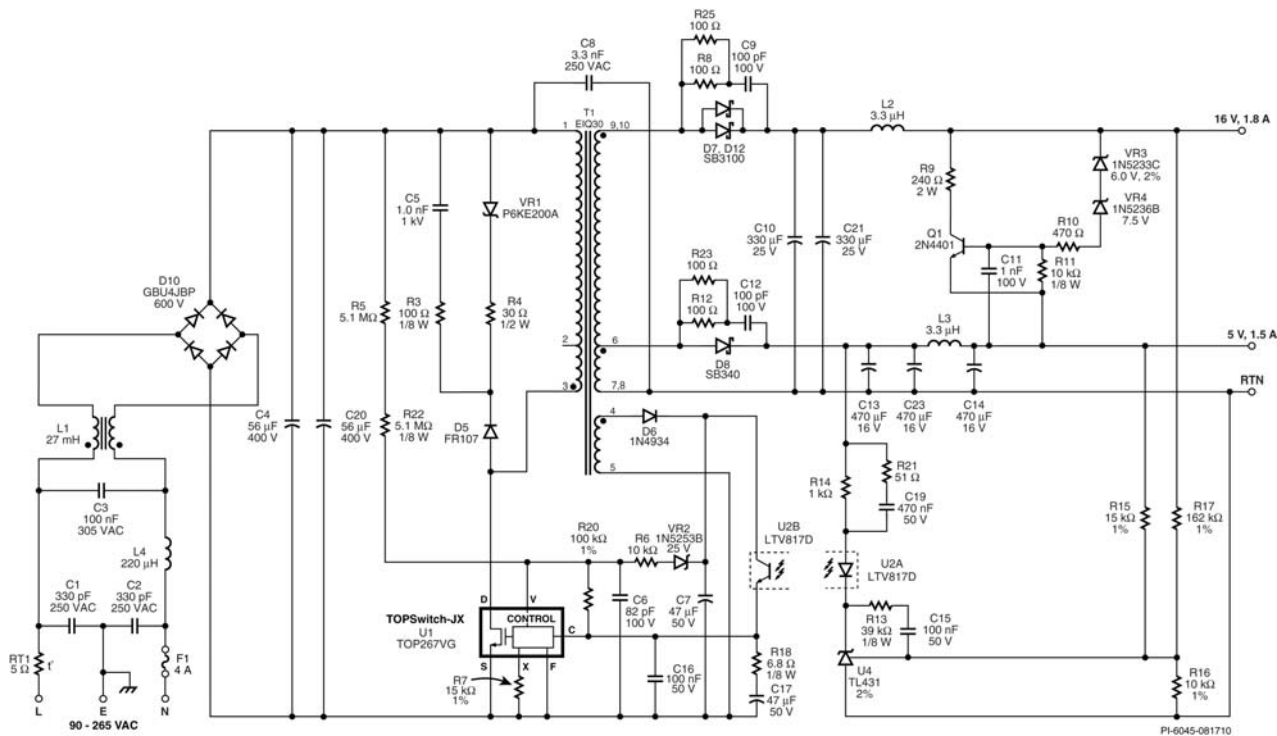

Figure 2 – Schematic.



4 Circuit Description

The power supply employs a TOPSwitch-JX TOP267VG device (U1) with an integrated high-voltage MOSFET and controller in a flyback configuration.

4.1 Input EMI Filtering and Rectification

Capacitors C1, C2 and C3 together with common mode choke L1 and differential mode choke L4 form a filter that attenuates both common mode and differential mode conducted EMI. Diode Bridge D10 rectifies the AC input which is then filtered by C4 and C20.

4.2 TOPSwitch-JX Primary

The TOP267VG device (U1) integrates an oscillator, a switch controller, start-up and protection circuitry, and a power MOSFET, all on one monolithic IC. One side of the power transformer (T1) primary winding is connected to the positive side of the bulk capacitor C4 and the other side is connected to the DRAIN pin of U1. During the on-time of the internal MOSFET, current ramps in the primary winding. When the MOSFET turns off, the leakage inductance of the transformer induces a voltage spike on the drain node. The amplitude of that spike is limited by two clamping networks that consist of D5, R4, VR1, R3 and C5. The majority of the dissipation occurs in the first network of VR1 and R4. The second network consists series connected R3 and C5 (in parallel with R4 and VR1) to reduce high frequency ringing. Resistor R4 determines the proportion of dissipation between the two networks. This arrangement was selected to reduce clamp losses under light and no-load conditions.

The line undervoltage threshold of 95 VDC is determined by the current supplied via resistors R5, R22 and R20 and the V pin current threshold of 25 μ A. The addition of R20 reduces the dissipation of R5 and R22, improving no-load input power. This also effectively disabled the line OV shutdown (threshold is >800 VDC) but the design easily passed differential surge levels above the 1 kV. The value of R20 was selected to ensure that the V pin current is above the UV threshold when the CONTROL pin is at 4.8 V during auto-restart. This ensures correct auto-restart timing. Resistor R6 and Zener diode VR2 are used for output overvoltage protection, for example during an open loop fault, triggering non-latching shut-down when the V pin current exceeds 112 μ A.

4.3 Output Rectification

Diode D8 rectifies the 5 V secondary winding output of T1. The output voltage is filtered by C13, C23, L3, and C14. Resistors R12, R23 and capacitor C12 snubs the voltage spike caused by the commutation of D8. Diodes D7 and D12 rectify the 16 V secondary winding output of T1. The output voltage is filtered by C10, C21 and L2. Resistors R8, R25 and capacitor C9 absorb the spike caused by the commutation of D7, D12. Multiple axial diodes were used for D8, D7 and D12 for both low cost but maintaining high efficiency and low temperature without heatsinks compared to single TO-220 higher current diodes with external heatsinks. The axial diodes are co-located and share the same copper area on the cathode side to ensure thermal tracking. The resultant current



sharing was excellent as can be seen in the thermal image where the diodes are operating at the same temperature indicating similar diode currents.

4.4 Output Feedback

The output voltage regulation is set by voltage dividers formed by R15, R17 and R16 and the shunt regulator U4. Resistor R13 and capacitor C15 are compensation elements around error amplifier U4. A high CTR optocoupler was selected for U2 to minimize the secondary side feedback (opto) current and thereby reduce no-load and standby input power. To reduce the feedback losses on the primary side the number of bias winding turns on the transformer and the value of C7 was optimized to give a minimum voltage of around 8 V at high line under standby loading conditions.

An active pre-load (shunt-regulator) was included to prevent an unloaded 16 V output rising outside of specification while the 5 V is loaded. This circuit is formed by VR3, VR4, R10, R11, C11, Q1 and R9. When the difference between the 5 V and 16 V outputs exceeds the voltage defined by VR3, VR4 and the V_{BE} of Q1, Q1 is biased on and current is shunted from the 16 V output into the 5 V output via R19. If the 16 V output always has a minimum load then this circuit can be omitted.



5 PCB Layout

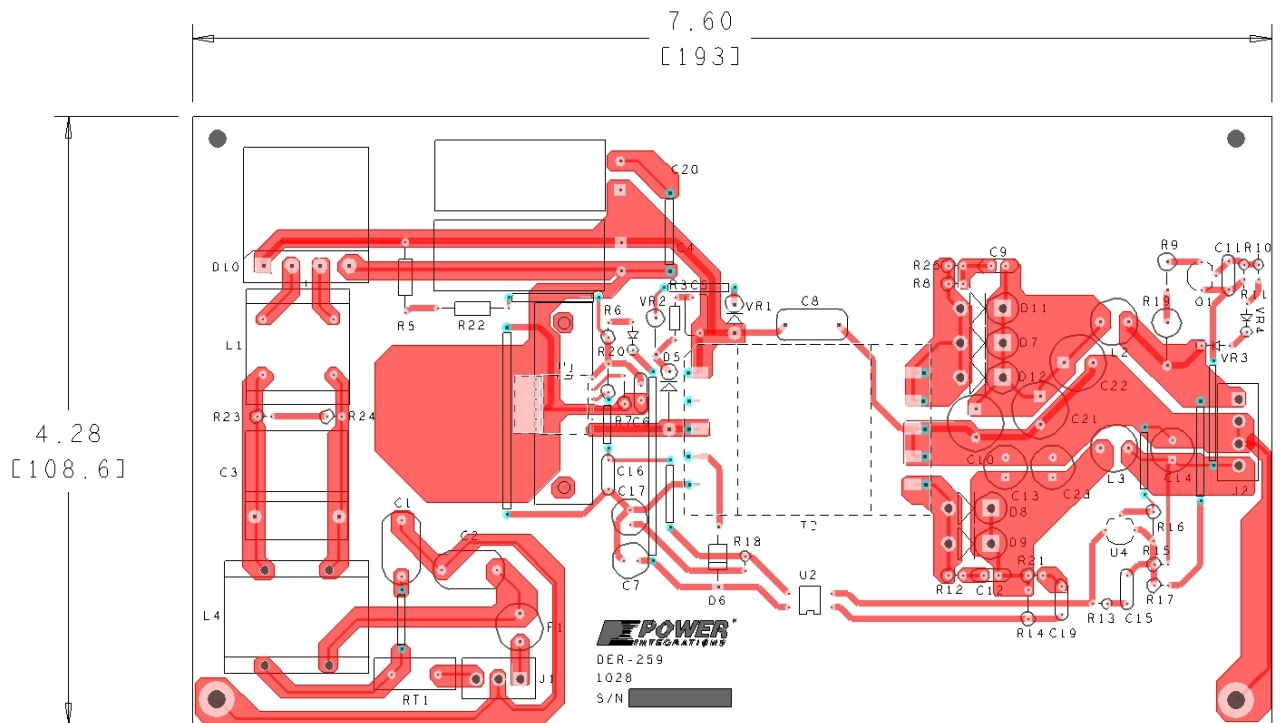

Figure 3 – PCB Layout.



6 Bill of Materials

Item	Qty	Ref Des	Description	Mfg Part Number	Manufacturer
1	2	C1 C2	330 pF, 250 VAC, Film, X1Y1	CD70-B2GA221KYAS	TDK
2	1	C3	100 nF, 305 VAC, X2	B32922A2104M	Epcos
3	2	C4 C20	68 μ F, 400 V, Electrolytic, Low ESR, (12.5 x 40)	EPAG401ELL680MK40S	Nippon Chemi-Con
4	1	C5	0.001 μ F, 1 kV, Disc Ceramic	562R10TSD10	Vishay
5	1	C6	82 pF, 100 V, Ceramic, COG	B37979N1820J000	Epcos
6	1	C7	47 μ F, 50 V, Electrolytic, Low ESR, 450 m Ω , (6.3 x 11.5)	ELXZ500ELL470MFB5D	Nippon Chemi-Con
7	1	C8	3.3 nF, Ceramic, Y1	440LD33-R	Vishay
8	2	C9 C12	100 pF, 100 V, Ceramic, COG	B37979N1101J000	Epcos
9	2	C10 C21	330 μ F, 25 V, Electrolytic, Very Low ESR, 53 m Ω , (10 x 12.5)	EKZE250ELL331MJC5S	Nippon Chemi-Con
10	1	C11	1 nF, 100 V, Ceramic, COG	B37979G1102J000	Epcos
11	3	C13 C14 C23	470 μ F, 16 V, Electrolytic, Low ESR, (8 x 11.5)	16MCZ470M8X11.5	Rubycon
12	1	C15	100 nF, 50 V, Ceramic, Z5U, 2Lead Space	C317C104M5U5TA	Kemet
13	1	C16	100 nF, 50 V, Ceramic, X7R	RPER71H104K2K1A03B	Murata
14	1	C17	47 μ F, 50 V, Electrolytic, Gen. Purpose, (6.3 x 11)	EKMG500ELL470MF11D	Nippon Chemi-Con
15	1	C19	470 nF, 50 V, Ceramic, X7R	B37984M5474K000	Epcos
16	1	D5	1000 V, 1 A, Fast Recovery Diode, DO-41	FR107-T-F	Diodes Inc.
17	1	D6	100 V, 1 A, Fast Recovery, 200 ns, DO-41	1N4934	Vishay
18	2	D7 D12	100 V, 3 A, Schottky, DO-201AD	SB3100-T	Diodes Inc
19	1	D8	40 V, 3 A, Schottky, DO-201AD	SB340-E3	Vishay
20	1	D10	600 V, 4 A, Bridge Rectifier, GBU Case	GBU4J-BP	Micro Commercial
21	1	F1	4 A, 250V, Slow, TR5	37214000411	Wickman
22	1	J1	3 Position (1 x 3) header, 0.156 pitch, Vertical	26-48-1031	Molex
23	1	J2	4 Position (1 x 4) header, 0.156 pitch, Vertical	26-48-1045	Molex
24	1	L1	27 mH, 0.9 A, Common Mode Choke		
25	2	L2 L3	3.3 μ H, 5.5 A	RL622-3R3K-RC	JW Miller
26	1	L4	220 μ H, 2 A	4590R-224K	API Delevan
27	4	MTG HOLE	Mounting Hole No 4		
28	1	Q1	NPN, Small Signal BJT, 40 V, 0.6 A, TO-92	2N4401G	On Semiconductor
29	1	R3	100 Ω , 5%, 1/8 W, Carbon Film	CFR-12JB-100R	Yageo
30	1	R4	30 Ω , 5%, 1/2 W, Carbon Film	CFR-50JB-30R	Yageo
31	2	R5 R22	5.1 M Ω , 5%, 1/8 W, Carbon Film	CFR-12JB-5M1	Yageo
32	1	R6	10 k Ω , 5%, 1/4 W, Carbon Film	CFR-25JB-10K	Yageo
33	2	R7 R15	15 k Ω , 1%, 1/4 W, Metal Film	MFR-25FBF-15K0	Yageo
34	4	R8 R12 R23 R25	100 Ω , 5%, 1/4 W, Carbon Film	CFR-25JB-100R	Yageo
35	1	R9	240 Ω , 5%, 2 W, Metal Oxide	RSF200JB-240R	Yageo
36	1	R10	470 Ω , 5%, 1/8 W, Carbon Film	CFR-12JB-470R	Yageo
37	1	R11	10 k Ω , 5%, 1/8 W, Carbon Film	CFR-12JB-10K	Yageo
38	1	R13	39 k Ω , 5%, 1/8 W, Carbon Film	CFR-12JB-39K	Yageo
39	1	R14	1 k Ω , 5%, 1/4 W, Carbon Film	CFR-25JB-1K0	Yageo
40	1	R16	10 k Ω , 1%, 1/4 W, Metal Film	ERO-S2PHF1002	Panasonic
41	1	R17	162 k Ω , 1%, 1/4 W, Metal Film	MFR-25FBF-162K	Yageo
42	1	R18	6.8 Ω , 5%, 1/8 W, Carbon Film	CFR-12JB-6R8	Yageo
43	1	R20	100 k Ω , 1%, 1/4 W, Metal Film	MFR-25FBF-100K	Yageo
44	1	R21	51 Ω , 5%, 1/4 W, Carbon Film	CFR-25JB-51R	Yageo
45	1	RT1	NTC Thermistor, 5 Ω , 2.8 A	CL160	Thermometrics
46	1	T1	Bobbin, EIQ30, 10pins,SMD		
47	1	U1	TopSwitch-JX, TOP267VG, eDIP-12P	TOP267VG	Power Integrations



48	1	U2	Opto coupler, 35 V, CTR 300-600%, 4-DIP	LTV-817D	Liteon
49	1	U4	2.495 V Shunt Regulator IC, 2%, 0 to 70C, TO-92	TL431CLPG	On Semiconductor
50	1	VR1	200 V, 5 W, 5%, TVS, DO204AC (DO-15)	P6KE200ARLG	On Semiconductor
51	1	VR2	25 V, 5%, 500 mW, DO-35	1N5253B-T	Diodes Inc
52	1	VR3	6.0 V, 2%, 500 mW, DO-35	1N5233C-TAP	Vishay
53	1	VR4	7.5 V, 5%, 500 mW, DO-35	1N5236B-TP	Micro Commercial



7 Transformer Specification

7.1 Electrical Diagram

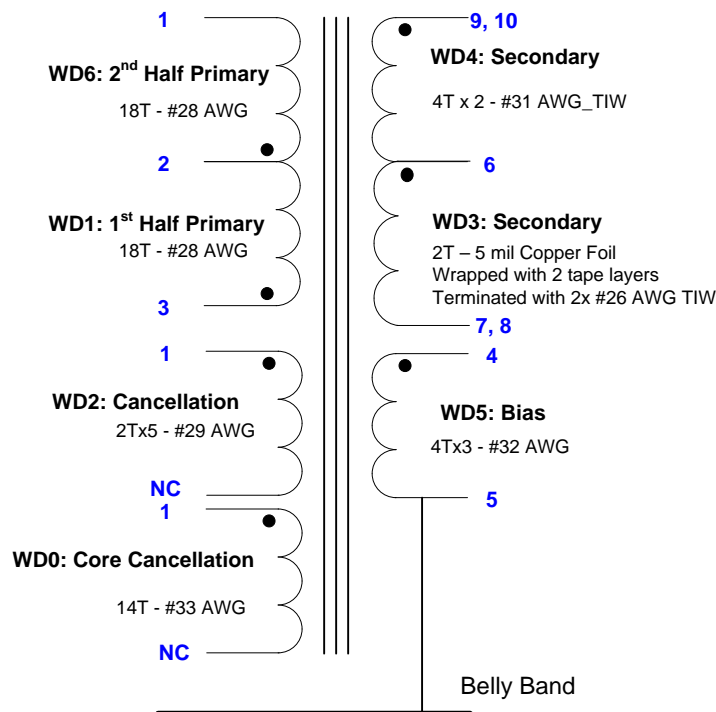

Figure 4 – Transformer Electrical Diagram.

7.2 Electrical Specifications

Electrical Strength	1 second, 60 Hz, from pins 1-6 to pins 7-12	3000 VAC
Primary Inductance	Pins 1-3, all other windings open, measured at 100 kHz, 0.4 VRMS	707 μ H, \pm 5%
Resonant Frequency	Pins 1-3, all other windings open	400 kHz (Min.)
Primary Leakage Inductance	Pins 1-3, with pins 6, 7, 8, 9, 10 shorted, measured at 100 kHz, 0.4 VRMS	25 μ H (Max.)

7.3 Materials

Item	Description
[1]	Core: EIQ30, 3F35 Ferroxcube, PLT30/20/3 AL= 4600 nH/T ² (UNGAPPED) or equivalent, gapped for ALG of 535 nH/t ²
[2]	Bobbin: EIQ30, vertical, 5 primary + 5 secondary
[3]	Barrier tape: 3M 1298 polyester film, 3.5 mm width
[4]	Magnet wire: #33 AWG, solderable double coated
[5]	Magnet wire: #28 AWG, solderable double coated
[6]	Magnet wire: #29 AWG, solderable double coated
[7]	Magnet wire: #32 AWG, solderable double coated



[8]	Triple Insulated Wire: #26 AWG
[9]	Triple Insulated Wire: #31 AWG
[10]	Copper foil: 5 mil thickness, 3.5 mm width
[11]	Copper foil: 2 mil thickness, 10 mm width
[12]	Varnish

7.4 Transformer Build Diagram

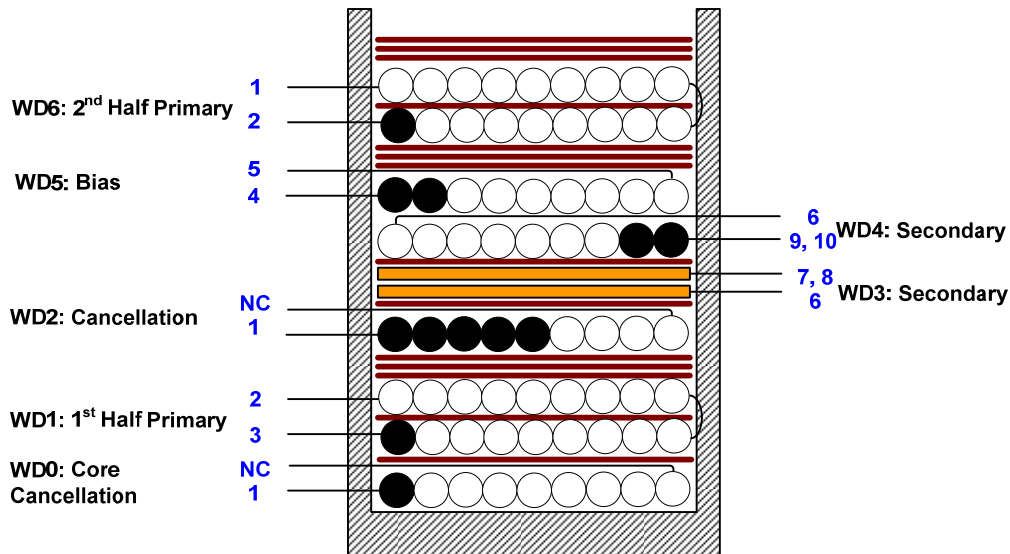

Figure 5 – Transformer Build Diagram.

7.5 Transformer Construction

WD0 Cancellation	Start on pin(s) 1, wind 14 turns of item [4] in 1 layer(s) from left to right. Spread the winding evenly across the entire bobbin. Cut the wire after finishing the 14 th turn.
Basic Insulation	Use 1 layer of tape, item [3], for insulation.
WD1 1st Half of Primary	Start on pin(s) 3, wind 9 turns of item [5] in 1 layer(s) from left to right. Apply one layer of tape, item [3]. Wind 9 turns of item [5] in 1 layer(s) from right to left. Finish this winding on pin(s) 2.
Basic Insulation	Use 3 layer of tape, item [3], for insulation.
WD2 Cancellation	Start on pin(s) 1, wind 2 (x5 filar) turns of item [6] in 1 layer(s) from left to right. Spread the winding evenly across the entire bobbin. Cut the wire after finishing the 2nd turn.
Basic Insulation	Use 1 layer of tape, item [3], for insulation.
WD3 Secondary Winding 5 V	Prepare the copper foil, item [10] with item [8] wires at two ends. Start on pin(s) 6, wind 2 turns of copper foil, item [10]. Finish on pins 7 and 8. Wind in same rotational direction as primary winding.
Basic Insulation	Use 1 layer of tape, item [3], for insulation.
WD4 Secondary Winding 16 V	Start on pins 9 and 10, wind 4 turns (x 2 filar) of item [9] from right to left. Wind in same rotational direction as primary winding. Spread the winding evenly across entire bobbin. Bring to wire back to secondary side and finish at pin(s) 6.



WD5 Bias	Start on pin(s) 4 and wind 4 turns (x 3 filar) of item [7]. Spread the winding evenly across entire bobbin. Finish this winding on pin(s) 5.
Basic Insulation	Use 3 layers of item [3] for basic insulation.
WD6 2nd Half of Primary	Start on pin(s) 2, wind 9 turns of item [5] in 1 layer(s) from left to right. Apply one layer of tape, item [3]. Wind 9 turns of item [5] in 1 layer(s) from right to left. Finish this winding on pin(s) 1.
Outer Wrap	Wrap windings with 3 layers of item [3].
Core Preparation	Prepare the core to get the correct primary inductance.
Final Assembly	Assemble and secure core halves with 2 layers of copper foil, item [11]. Connect the copper foil to pin 5 with wire.
Varnishing	Dip varnish the transformer in item [12].



8 Transformer Design Spreadsheet

ACDC_TOPSwitchJX_020110; Rev.1.2; Copyright Power Integrations 2010	INPUT	INFO	OUTPUT	UNIT	TOP_JX_020110: TOPSwitch-JX Continuous/Discontinuous Flyback Transformer Design Spreadsheet
ENTER APPLICATION VARIABLES					
VACMIN	90			Volts	Minimum AC Input Voltage
VACMAX	265			Volts	Maximum AC Input Voltage
fL	50			Hertz	AC Mains Frequency
VO	5.00			Volts	Output Voltage (main)
PO_AVG	36.30			Watts	Average Output Power
PO_PEAK			36.30	Watts	Peak Output Power
Heatsink Type	External		External		Heatsink Type
Enclosure	Open Frame				Open Frame enclosure assume sufficient airflow while adapter means a sealed enclosure.
n	0.79			%/100	Efficiency Estimate
Z	0.50				Loss Allocation Factor
VB	9	Info		Volts	Ensure proper operation at no load.
tC	3.00			ms	Bridge Rectifier Conduction Time Estimate
CIN	112.0		112	uFarads	Input Filter Capacitor
ENTER TOPSWITCH-JX VARIABLES					
TOPSwitch-JX	TOP267V			Universal / Peak	115 Doubled/230V
Chosen Device		TOP267V	Power Out	103 W / 103 W	137W
KI	0.47				External limit reduction factor (KI=1.0 for default ILIMIT, KI <1.0 for lower ILIMIT)
ILIMITMIN_EXT			1.316	Amps	Use 1% resistor in setting external ILIMIT
ILIMITMAX_EXT			1.513	Amps	Use 1% resistor in setting external ILIMIT
Frequency (F)=132kHz, (H)=66kHz	F		F		Select 'H' for Half frequency - 66kHz, or 'F' for Full frequency - 132kHz
fS			132000	Hertz	TOPSwitch-JX Switching Frequency: Choose between 132 kHz and 66 kHz
fSmin			119000	Hertz	TOPSwitch-JX Minimum Switching Frequency
fSmax			145000	Hertz	TOPSwitch-JX Maximum Switching Frequency
High Line Operating Mode			FF		Full Frequency, Jitter enabled
VOR	100.00			Volts	Reflected Output Voltage
VDS			10	Volts	TOPSwitch on-state Drain to Source Voltage
VD	0.50			Volts	Output Winding Diode Forward Voltage Drop
VDB	0.70			Volts	Bias Winding Diode Forward Voltage Drop
KP	0.50				Ripple to Peak Current Ratio (0.3 < KRP < 1.0 : 1.0 < KDP < 6.0)
PROTECTION FEATURES					
LINE SENSING					
VUV_STARTUP			84	Volts	Minimum DC Bus Voltage at which the power supply will start-up
VOV_SHUTDOWN			400	Volts	Typical DC Bus Voltage at which power supply will shut-down (Max)
RLS			3.6	M-ohms	Use two standard, 1.8 M-Ohm, 5% resistors in series for line sense functionality.
OUTPUT OVERVOLTAGE					
VZ			16	Volts	Zener Diode rated voltage for Output



RZ			5.1	k-ohms	Overshoot protection Output OVP resistor. For latching shutdown use 20 ohm resistor instead
OVERLOAD POWER LIMITING					X pin functionality
Overload Current Ratio at VMAX			1.2		Enter the desired margin to current limit at VMAX. A value of 1.2 indicates that the current limit should be 20% higher than peak primary current at VMAX
Overload Current Ratio at VMIN			1.11		Margin to current limit at low line.
ILIMIT_EXT_VMIN			1.17	A	Peak primary Current at VMIN
ILIMIT_EXT_VMAX			1.00	A	Peak Primary Current at VMAX
RIL			12.94	k-ohms	Current limit/Power Limiting resistor.
RPL			N/A	M-ohms	Resistor not required. Use RIL resistor only
ENTER TRANSFORMER CORE/CONSTRUCTION VARIABLES					
Core Type	EIQ30		EIQ30		Core Type
Core		#N/A		P/N:	#N/A
Bobbin		#N/A		P/N:	#N/A
AE	1.0800		1.08	cm ²	Core Effective Cross Sectional Area
LE	3.6200		3.62	cm	Core Effective Path Length
AL	4600.0		4600	nH/T ²	Ungapped Core Effective Inductance
BW	3.5		3.5	mm	Bobbin Physical Winding Width
M	0.00			mm	Safety Margin Width (Half the Primary to Secondary Creepage Distance)
L	4.00				Number of Primary Layers
NS			2		Number of Secondary Turns
DC INPUT VOLTAGE PARAMETERS					
VMIN	99		99	Volts	Minimum DC Input Voltage
VMAX			375	Volts	Maximum DC Input Voltage
CURRENT WAVEFORM SHAPE PARAMETERS					
DMAX			0.53		Maximum Duty Cycle (calculated at PO_PEAK)
Iavg			0.46	Amps	Average Primary Current (calculated at average output power)
IP			1.17	Amps	Peak Primary Current (calculated at Peak output power)
IR			0.58	Amps	Primary Ripple Current (calculated at average output power)
IRMS			0.65	Amps	Primary RMS Current (calculated at average output power)
TRANSFORMER PRIMARY DESIGN PARAMETERS					
LP			707	uHenries	Primary Inductance
LP Tolerance	5		5		Tolerance of Primary Inductance
NP			36		Primary Winding Number of Turns
NB			4		Bias Winding Number of Turns
ALG			535	nH/T ²	Gapped Core Effective Inductance
BM			2107	Gauss	Maximum Flux Density at PO, VMIN (BM<3000)
BP			2862	Gauss	Peak Flux Density (BP<4200) at ILIMITMAX and LP_MAX. Note: Recommended values for adapters and external power supplies <=3600 Gauss
BAC			527	Gauss	AC Flux Density for Core Loss Curves (0.5 X Peak to Peak)
ur			1227		Relative Permeability of Ungapped Core
LG			0.22	mm	Gap Length (Lg > 0.1 mm)
BWE			14	mm	Effective Bobbin Width
OD			0.39	mm	Maximum Primary Wire Diameter including insulation
INS			0.06	mm	Estimated Total Insulation Thickness



					(= 2 * film thickness)
DIA			0.33	mm	Bare conductor diameter
AWG			28	AWG	Primary Wire Gauge (Rounded to next smaller standard AWG value)
CM			161	Cmils	Bare conductor effective area in circular mils
CMA			248	Cmils/Amp	Primary Winding Current Capacity (200 < CMA < 500)
Primary Current Density (J)			8.08	Amps/mm ²	Primary Winding Current density (3.8 < J < 9.75)
TRANSFORMER SECONDARY DESIGN PARAMETERS (SINGLE OUTPUT EQUIVALENT)					
Lumped parameters					
ISP			21.27	Amps	Peak Secondary Current
ISRMS			11.15	Amps	Secondary RMS Current
IO_PEAK			7.26	Amps	Secondary Peak Output Current
IO			7.26	Amps	Average Power Supply Output Current
IRIPPLE			8.46	Amps	Output Capacitor RMS Ripple Current
CMS			2229	Cmils	Secondary Bare Conductor minimum circular mils
AWGS			16	AWG	Secondary Wire Gauge (Rounded up to next larger standard AWG value)
DIAS			1.29	mm	Secondary Minimum Bare Conductor Diameter
ODS			1.75	mm	Secondary Maximum Outside Diameter for Triple Insulated Wire
INSS			0.23	mm	Maximum Secondary Insulation Wall Thickness
VOLTAGE STRESS PARAMETERS					
VDRAIN			575	Volts	Maximum Drain Voltage Estimate (Includes Effect of Leakage Inductance)
PIVS			26	Volts	Output Rectifier Maximum Peak Inverse Voltage
PIVB			45	Volts	Bias Rectifier Maximum Peak Inverse Voltage
TRANSFORMER SECONDARY DESIGN PARAMETERS (MULTIPLE OUTPUTS)					
1st output					
VO1			5	Volts	Output Voltage
IO1_AVG	1.50		1.50	Amps	Average DC Output Current
PO1_AVG			7.50	Watts	Average Output Power
VD1			0.5	Volts	Output Diode Forward Voltage Drop
NS1			2.00		Output Winding Number of Turns
ISRMS1			2.303	Amps	Output Winding RMS Current
IRIPPLE1			1.75	Amps	Output Capacitor RMS Ripple Current
PIVS1			26	Volts	Output Rectifier Maximum Peak Inverse Voltage
CMS1			461	Cmils	Output Winding Bare Conductor minimum circular mils
AWGS1			23	AWG	Wire Gauge (Rounded up to next larger standard AWG value)
DIAS1			0.58	mm	Minimum Bare Conductor Diameter
ODS1			1.75	mm	Maximum Outside Diameter for Triple Insulated Wire
2nd output					
VO2	16.00			Volts	Output Voltage
IO2_AVG	1.80			Amps	Average DC Output Current
PO2_AVG			28.80	Watts	Average Output Power
VD2			0.7	Volts	Output Diode Forward Voltage Drop
NS2			6.07		Output Winding Number of Turns
ISRMS2			2.763	Amps	Output Winding RMS Current
IRIPPLE2			2.10	Amps	Output Capacitor RMS Ripple Current
PIVS2			79	Volts	Output Rectifier Maximum Peak



					Inverse Voltage
CMS2			553	Cmils	Output Winding Bare Conductor minimum circular mils
AWGS2			22	AWG	Wire Gauge (Rounded up to next larger standard AWG value)
DIAS2			0.65	mm	Minimum Bare Conductor Diameter
ODS2			0.58	mm	Maximum Outside Diameter for Triple Insulated Wire
3rd output					
VO3				Volts	Output Voltage
IO3_AVG				Amps	Average DC Output Current
PO3_AVG			0.00	Watts	Average Output Power
VD3			0.7	Volts	Output Diode Forward Voltage Drop
NS3			0.25		Output Winding Number of Turns
ISRMS3			0.000	Amps	Output Winding RMS Current
IRIPPLE3			0.00	Amps	Output Capacitor RMS Ripple Current
PIVS3			3	Volts	Output Rectifier Maximum Peak Inverse Voltage
CMS3			0	Cmils	Output Winding Bare Conductor minimum circular mils
AWGS3			N/A	AWG	Wire Gauge (Rounded up to next larger standard AWG value)
DIAS3			N/A	mm	Minimum Bare Conductor Diameter
ODS3			N/A	mm	Maximum Outside Diameter for Triple Insulated Wire
Total Continuous Output Power			36.3	Watts	Total Continuous Output Power
Negative Output			N/A		If negative output exists enter Output number; eg: If VO2 is negative output, enter 2



9 Performance Data

All measurements performed at room temperature. Unless otherwise specified, all testing performed with a line frequency of 50 Hz except for 90 VAC and 115 VAC where 60 Hz was used.

9.1 Full Load Efficiency

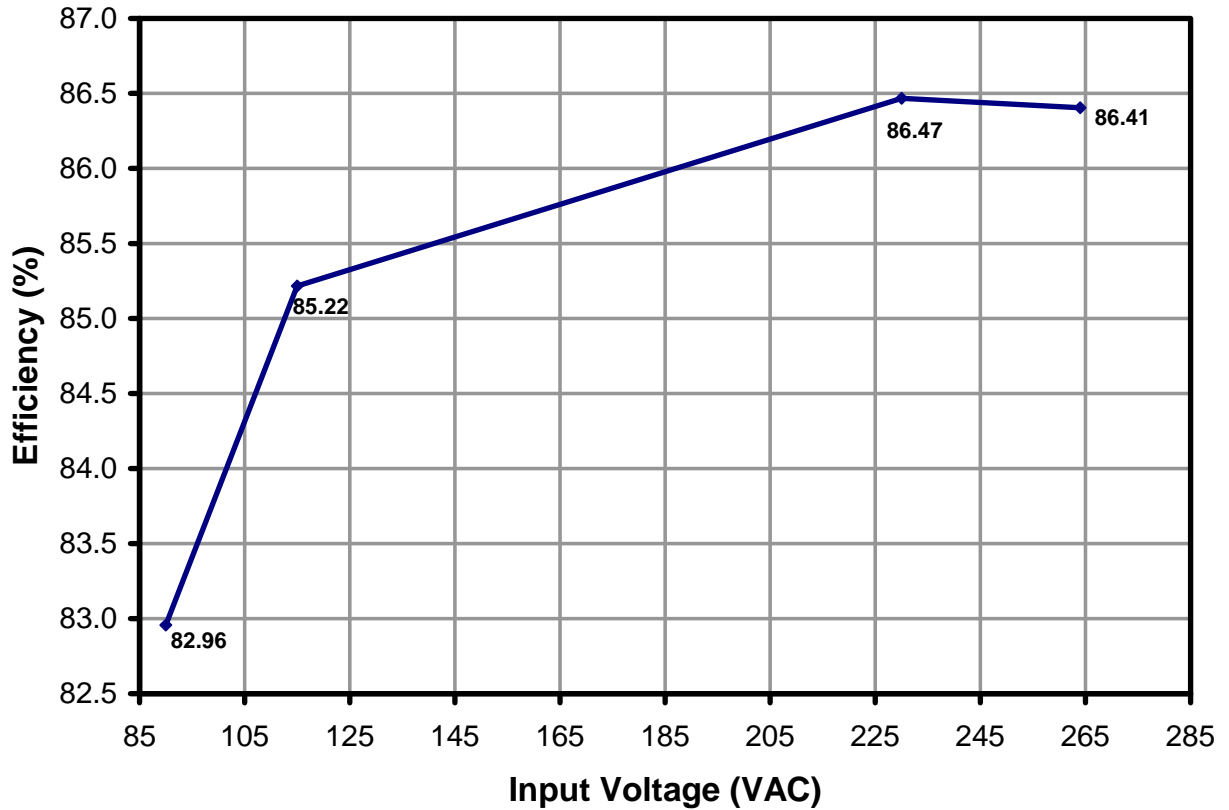

Figure 6 – Efficiency vs. Input Voltage, 60 Hz, Full Load, Room Temperature.



9.2 Input Power with 5 mA and 6 mA Load at 5 V Output

Measured with 16 V output unloaded.

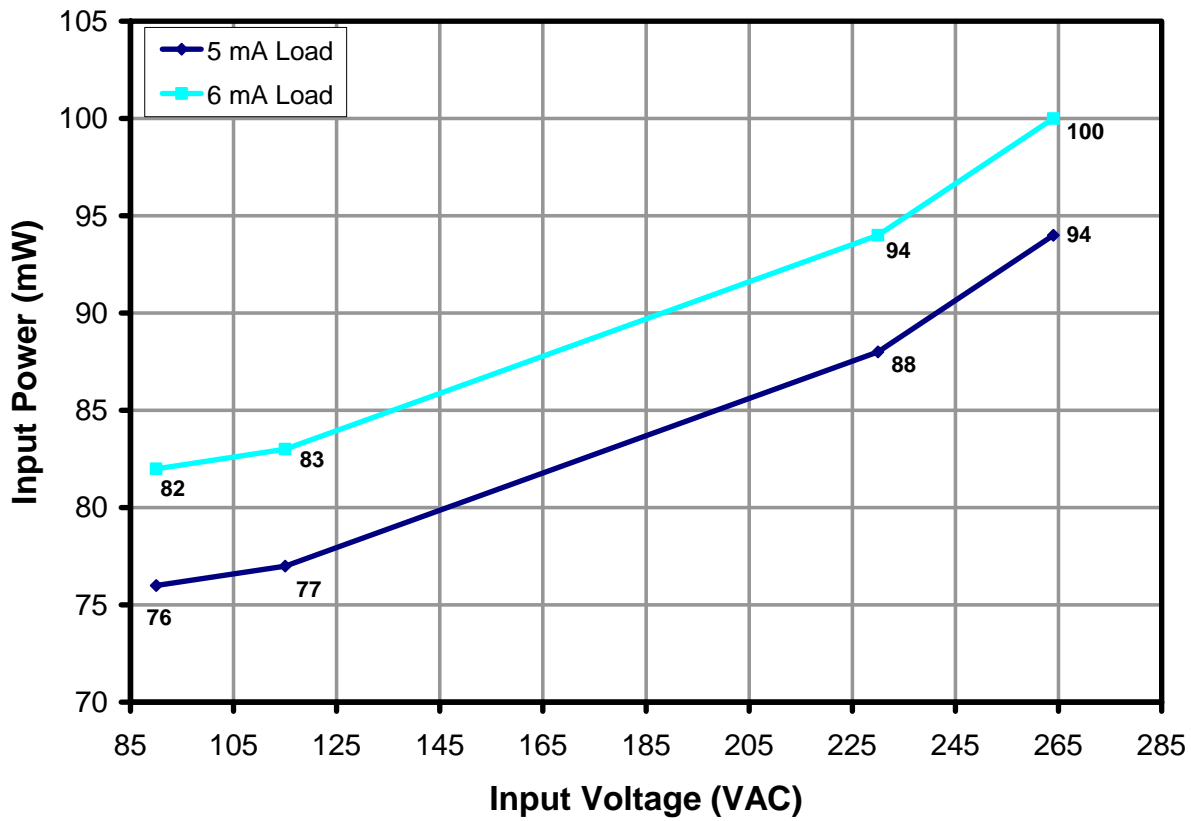

Figure 7 – Input Power with 5 mA and 6 mA Load at 5 V. Output vs. Line Voltage.



9.3 No-load Input Power

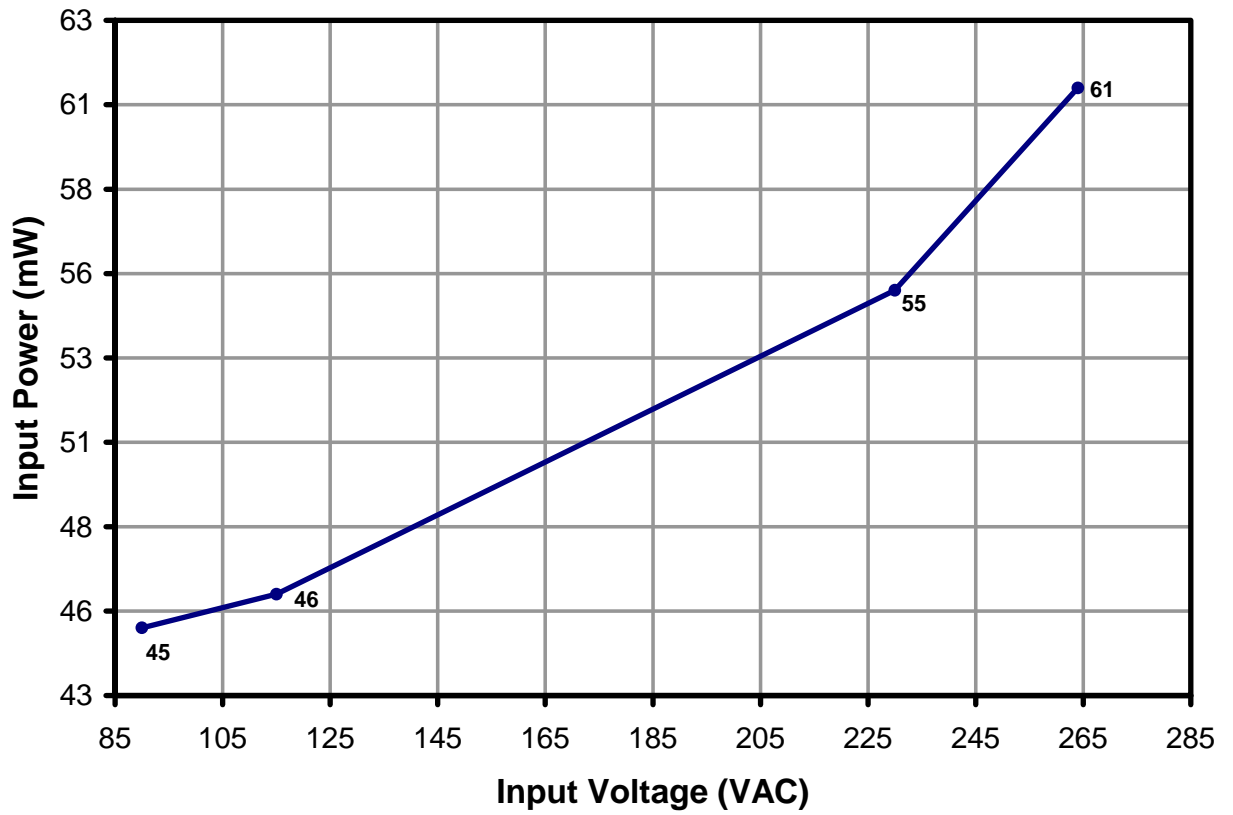

Figure 8 – No-load Input Power vs. Line Voltage.



9.4 Regulation

9.4.1 Load

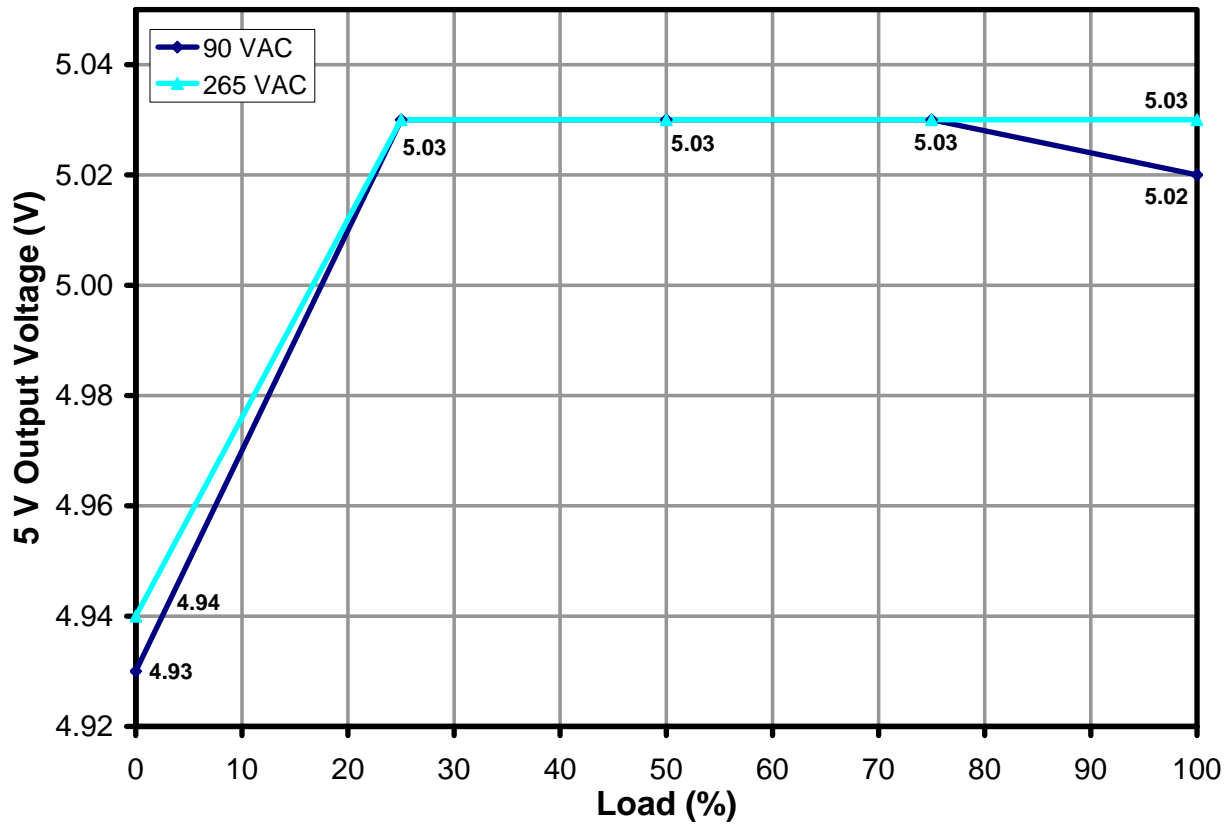

Figure 9 – 5 V Output Load Regulation, Room Temperature.



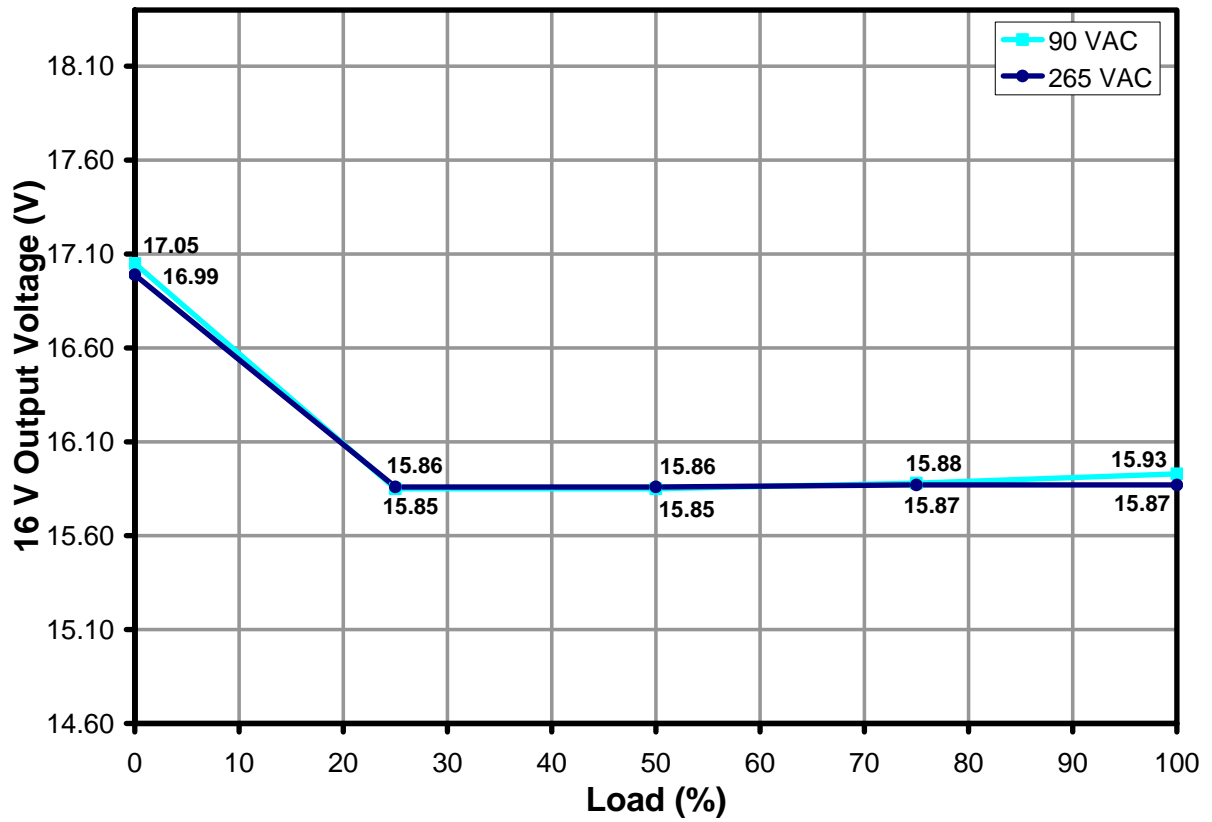

Figure 10 – 16 V Output Load Regulation, Room Temperature.

9.4.2 Line

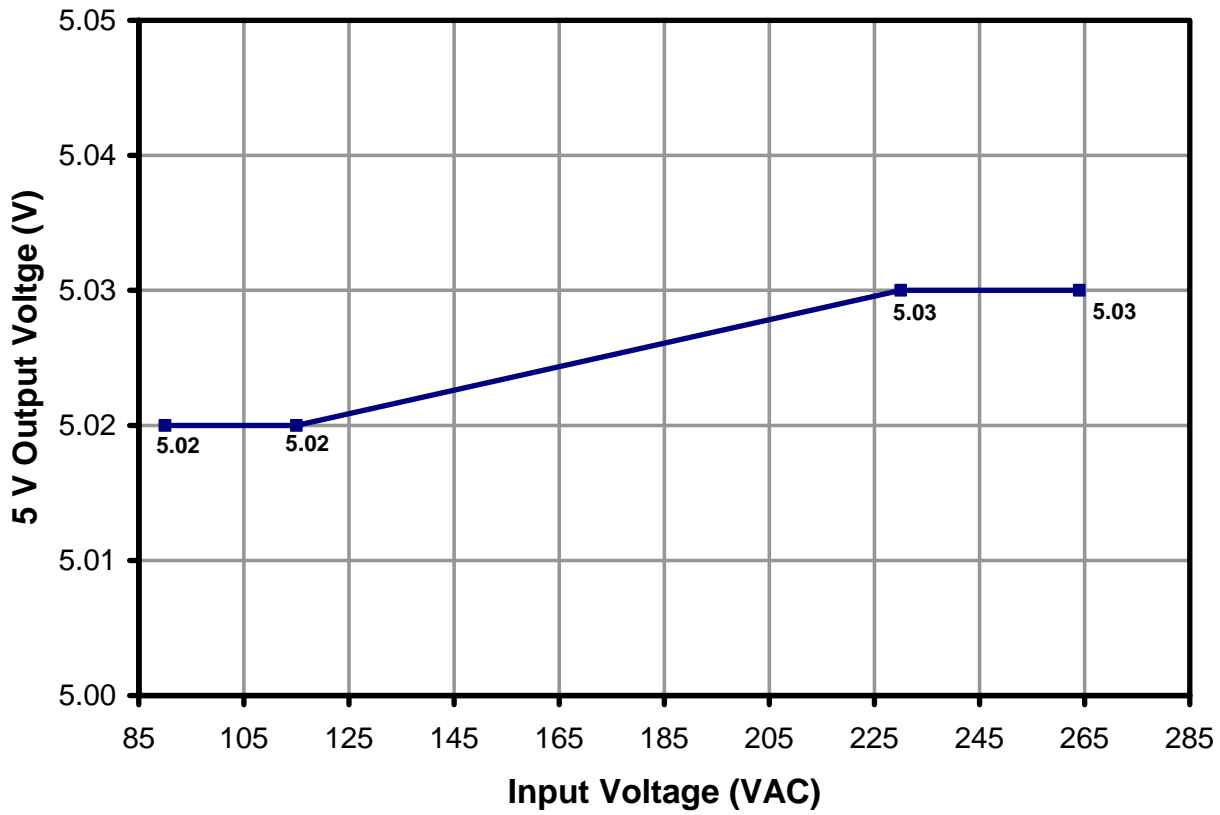

Figure 11 – 5 V Output Line Regulation, Room Temperature, Full Load.



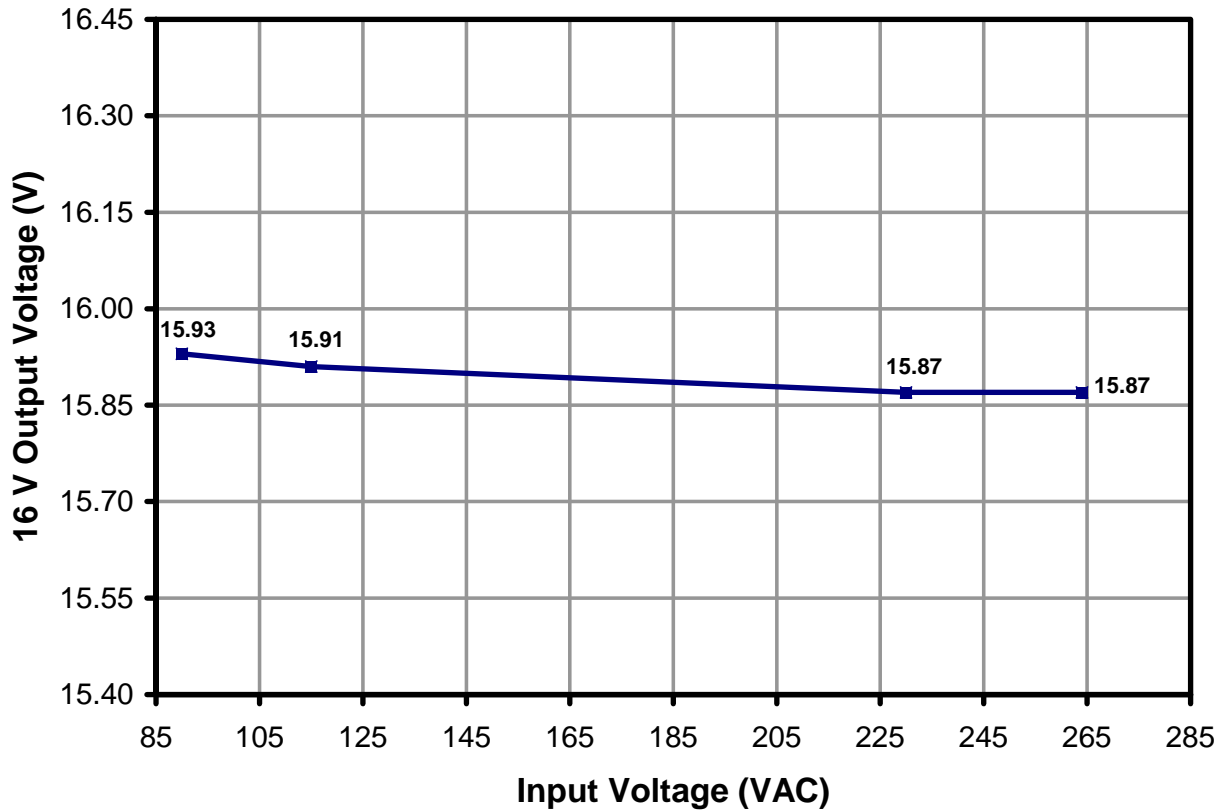

Figure 12 – 16 V Output Line Regulation, Room Temperature, Full Load.

9.4.3 Cross Regulation

	90 VAC		264 VAC	
	5 V OUT (V)	16 V OUT (V)	5 V OUT (V)	16 V OUT (V)
16 V / 1.8 A, 5 V / 2.5 A	5.02	15.93	5.03	15.87
16 V / 0 A, 5 V / 0 A	4.93	17.05	4.94	16.99
16 V / 0.1 A, 5 V / 2.5 A	4.89	17.45	4.88	17.57
16 V / 1.8 A, 5 V / 0.1 A	5.08	15.29	5.08	15.32



10 Thermal Performance

10.1 Thermal Performance at Room Temperature

The unit was running for two hours to thermally stabilize prior to the measurement. The unit was loaded at maximum load of 36.3 W at room temperature on the bench open frame.

Item	Temperature (°C)
	90 VAC / 60 Hz
Ambient	25
Common Mode Choke (L1)	46
Bridge (D10)	56
Transformer (T1)	71
PI Device (U1)	90
Rectifier for 5V (D8)	62
Rectifier for 16V (D12)	72

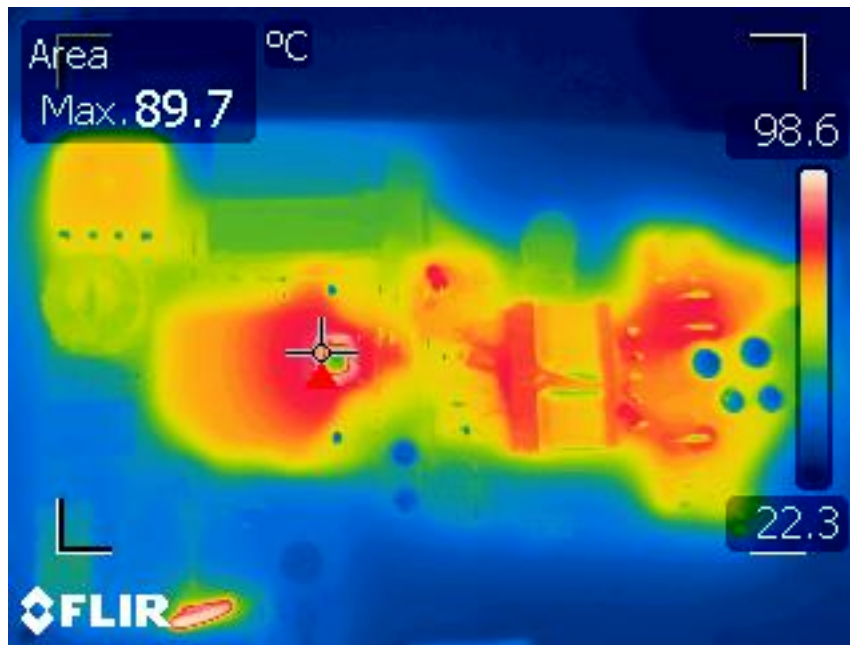

Figure 13 – Infra-Red Image of the Component Side after Two Hours Operation Full Load, 90 VAC, 60 Hz and Room Temperature, Open Frame.



10.2 Thermal Performance at 40°C Ambient Temperature

Item	Temperature (°C)
	90 VAC / 60 Hz
Ambient	40
Common Mode Choke (L1)	50
Bridge (D10)	60
Transformer (T1)	75
PI Device (U1)	95
Rectifier for 5 V (D8)	68
Rectifier for 16 V (D12)	76



11 Waveforms

11.1 Drain Voltage and Current, Normal Operation

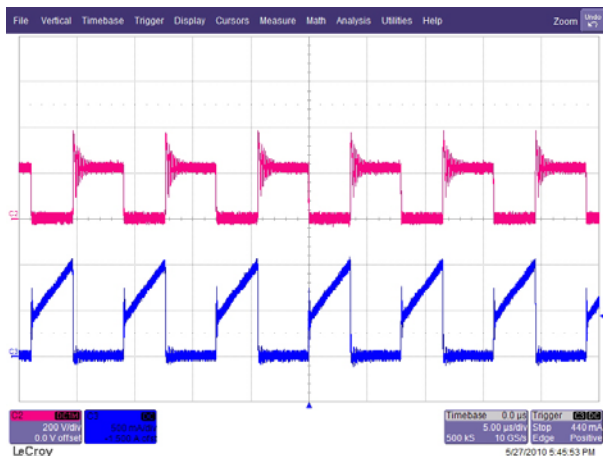

Figure 14 – 90 VAC, Full Load.
 Upper: V_{DRAIN} , 200 V / div.
 Lower: I_{DRAIN} , 0.5 A, 5 μ s / div.

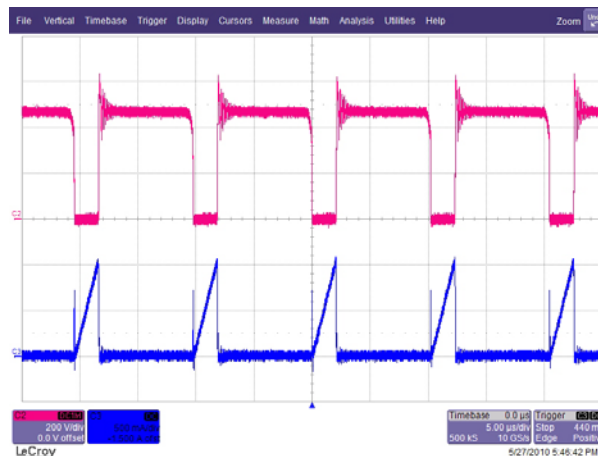

Figure 15 – 264 VAC, Full Load.
 Upper: V_{DRAIN} , 200 V / div.
 Lower: I_{DRAIN} , 0.5 A, 5 μ s / div.

11.2 Output Voltage Start-up Profile

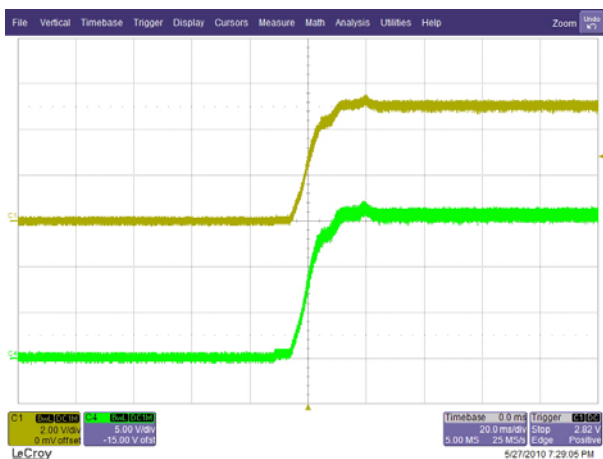

Figure 16 – Start-up Profile, 90 VAC.
 Upper: V_{5V} , 2 V / div.
 Lower: V_{16V} , 5 V, 20 ms / div.



Figure 17 – Start-up Profile, 264 VAC.
 Upper: V_{5V} , 2 V / div.
 Lower: V_{16V} , 5 V, 20 ms / div.



11.3 Drain Voltage and Current Start-up Profile



Figure 18 – 90 VAC Input and Full Load.
Upper: V_{DRAIN} , 200 V / div.
Lower: I_{DRAIN} , 0.5 A ,10 ms / div.

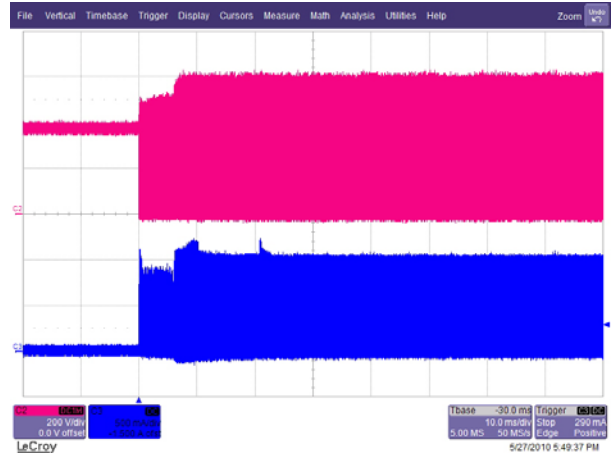

Figure 19 – 264 VAC Input and Full Load.
Upper: V_{DRAIN} , 200 V / div.
Lower: I_{DRAIN} , 0.5 A ,10 ms / div.

11.4 Load Transient Response (75% to 100% Load Step)

In the figures shown below, signal averaging was used to better enable viewing the load transient response. The oscilloscope was triggered using the load current step as a trigger source. Since the output switching and line frequency occur essentially at random with respect to the load transient, contributions to the output ripple from these sources will average out, leaving the contribution only from the load step response.

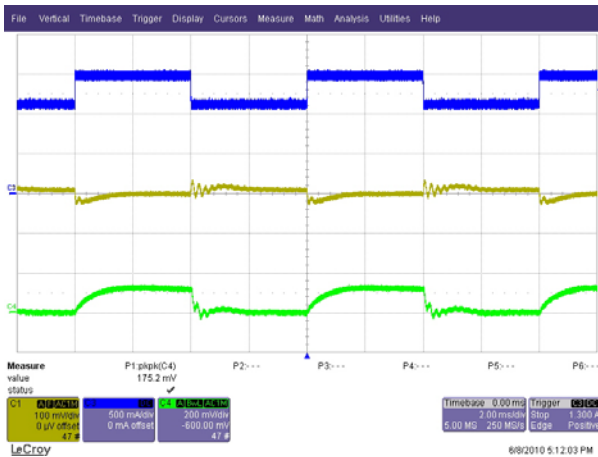

Figure 20 – Transient Response, 90 VAC,
75-100-75% Load Step at 5 V Output.
Top: Output Current, 500 mA / div.
Middle: 5 V Output, 100 mV / div.
Bottom: 16 V Output.
200 mV, 2 ms / div.

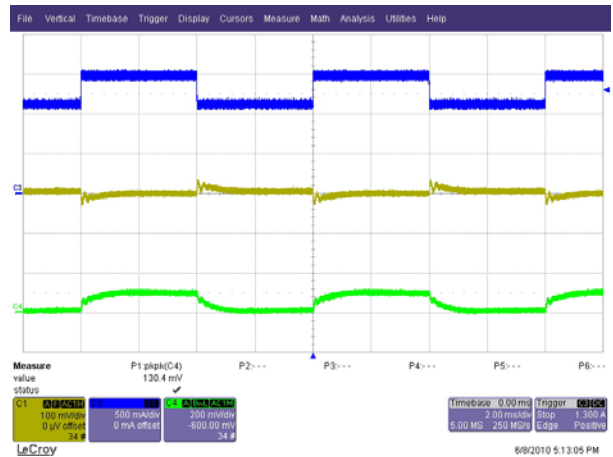

Figure 21 – Transient Response, 264 VAC,
75-100-75% Load Step at 5 V Output.
Top: Output Current, 500 mA / div.
Middle: 5 V Output, 100 mV / div.
Bottom: 16 V Output.
200 mV, 2 ms / div.



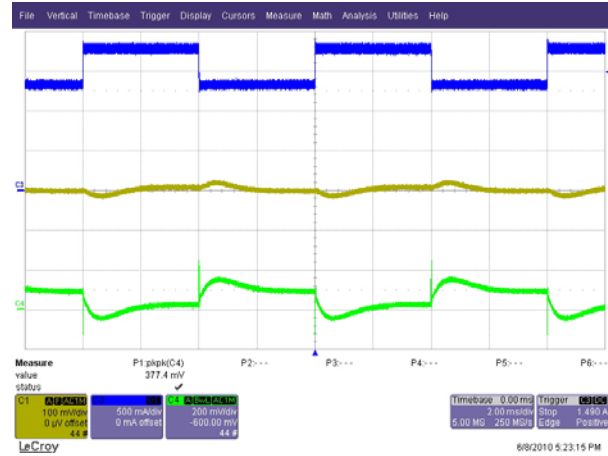
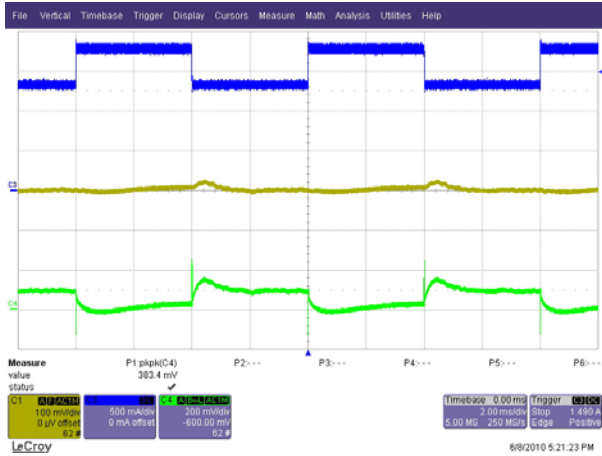

Figure 22 – Transient Response, 90 VAC, 75-100-75% Load Step at 16 V Output. Top: Output Current, 500 mA / div. Middle: 5 V Output, 100 mV / div. Bottom: 16 V Output, 200 mV, 2 ms / div.

Figure 23 – Transient Response, 264 VAC, 75-100-75% Load Step at 16 V Output. Top: Output Current, 500 mA / div. Middle: 5 V Output, 100 mV / div. Bottom: 16 V Output, 200 mV, 2 ms / div.

11.5 Output Overvoltage Protection

An output over voltage condition was simulated by shorting LED of the optocoupler (U2), with the output fully loaded. The resultant output oscillograph (below) shows the operation of the primary side OV shutdown via VR2 into the V pin.

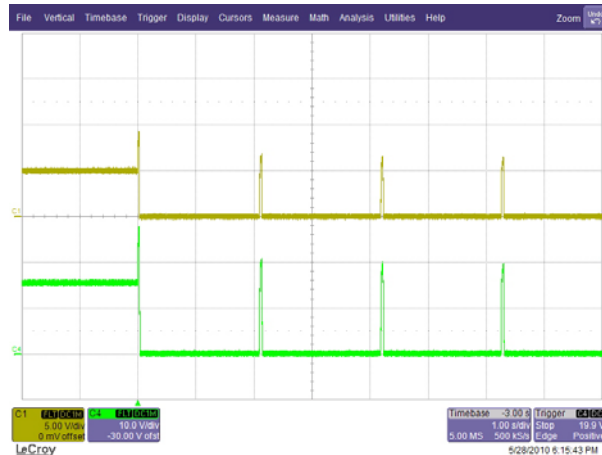

Figure 24 – Output Overvoltage Protection, 90 VAC.
 Top: 5 V Output Voltage, 5 V / div.
 Bottom: 16 V Output Voltage, 10 V / div., 1 ms / div.



11.6 Output Ripple Measurements

11.6.1 Ripple Measurement Technique

For DC output ripple measurements, a modified oscilloscope test probe must be utilized in order to reduce spurious signals due to pickup. Details of the probe modification are provided in the figures below.

The 4987BA probe adapter is affixed with two capacitors tied in parallel across the probe tip. The capacitors include one (1) 0.1 $\mu\text{F}/50\text{ V}$ ceramic type and one (1) 1.0 $\mu\text{F}/50\text{ V}$ aluminum electrolytic. The aluminum electrolytic type capacitor is polarized, so proper polarity across DC outputs must be maintained (see below).

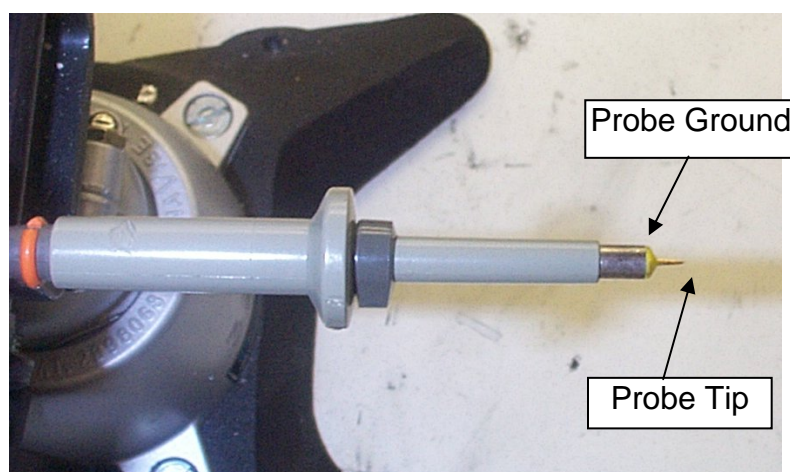

Figure 25 – Oscilloscope Probe Prepared for Ripple Measurement. (End Cap and Ground Lead Removed)



Figure 26 – Oscilloscope Probe with Probe Master (www.probemaster.com) 4987A BNC Adapter. (Modified with wires for ripple measurement, and two parallel decoupling capacitors added)



11.6.2 Measurement Results

Note: Measurements of ripple were made with the V pin of U1 connected to SOURCE pin. This was done to correctly simulate the performance of the final version of U1 which has an optimized V pin characteristic compared to the device used on this board.

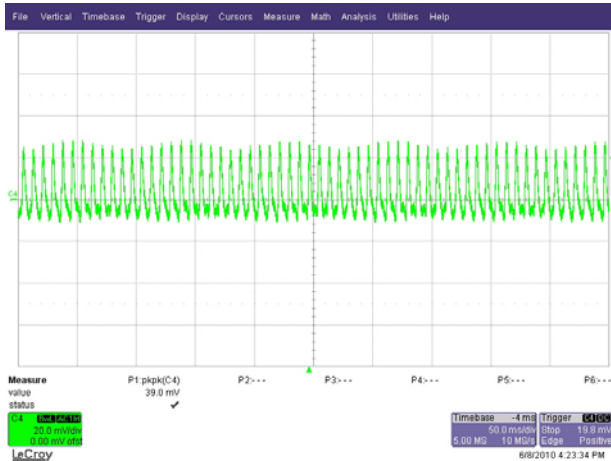

Figure 27 – 5 V Output Ripple [39 mV_{P-P}], 90 VAC, 60 Hz, Full Load. 20 mV, 50 ms / div.

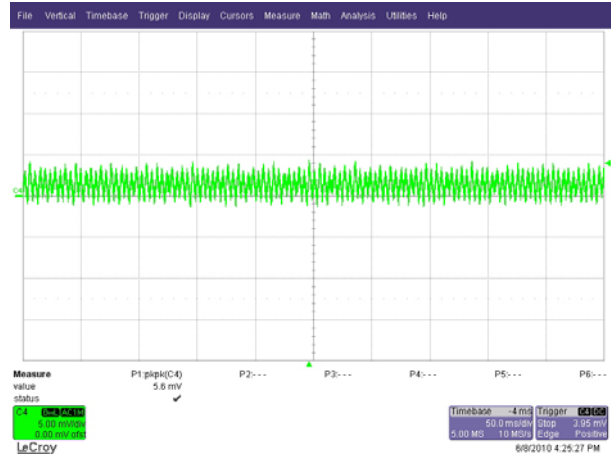

Figure 28 – 5 V Output Ripple [5.6 mV_{P-P}], 264 VAC, 50 Hz, Full Load. 5 mV, 50 ms / div.

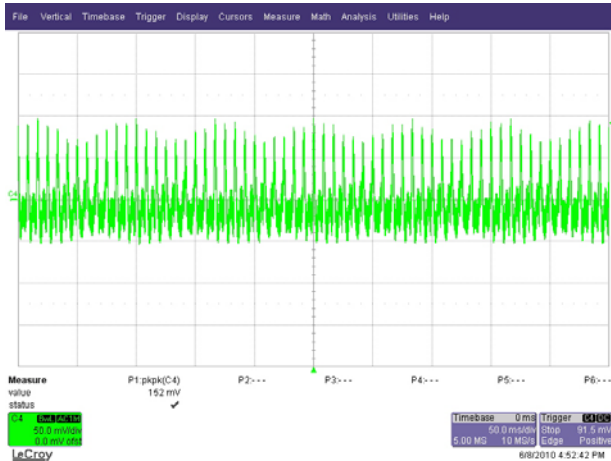

Figure 29 – 16 V Output Ripple [152 mV_{P-P}], 90 VAC, 50 Hz, Full Load. 50 mV, 50 ms / div.

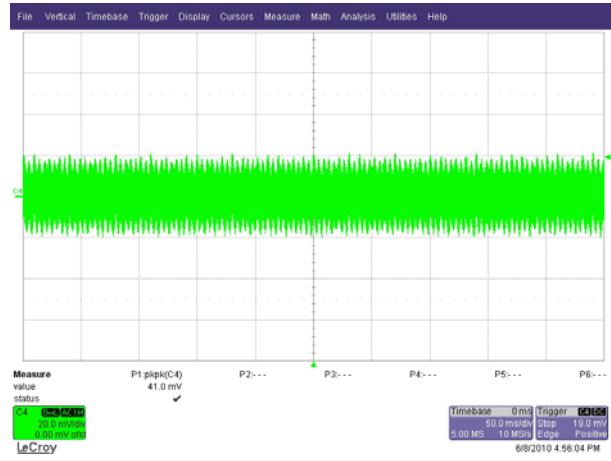

Figure 30 – 16 V Output Ripple, [41 mV_{P-P}] 264 VAC, 50 Hz, Full Load. 20 mV, 50 ms / div.

12 Control Loop Measurements

12.1 90 VAC 60 Hz Maximum Load

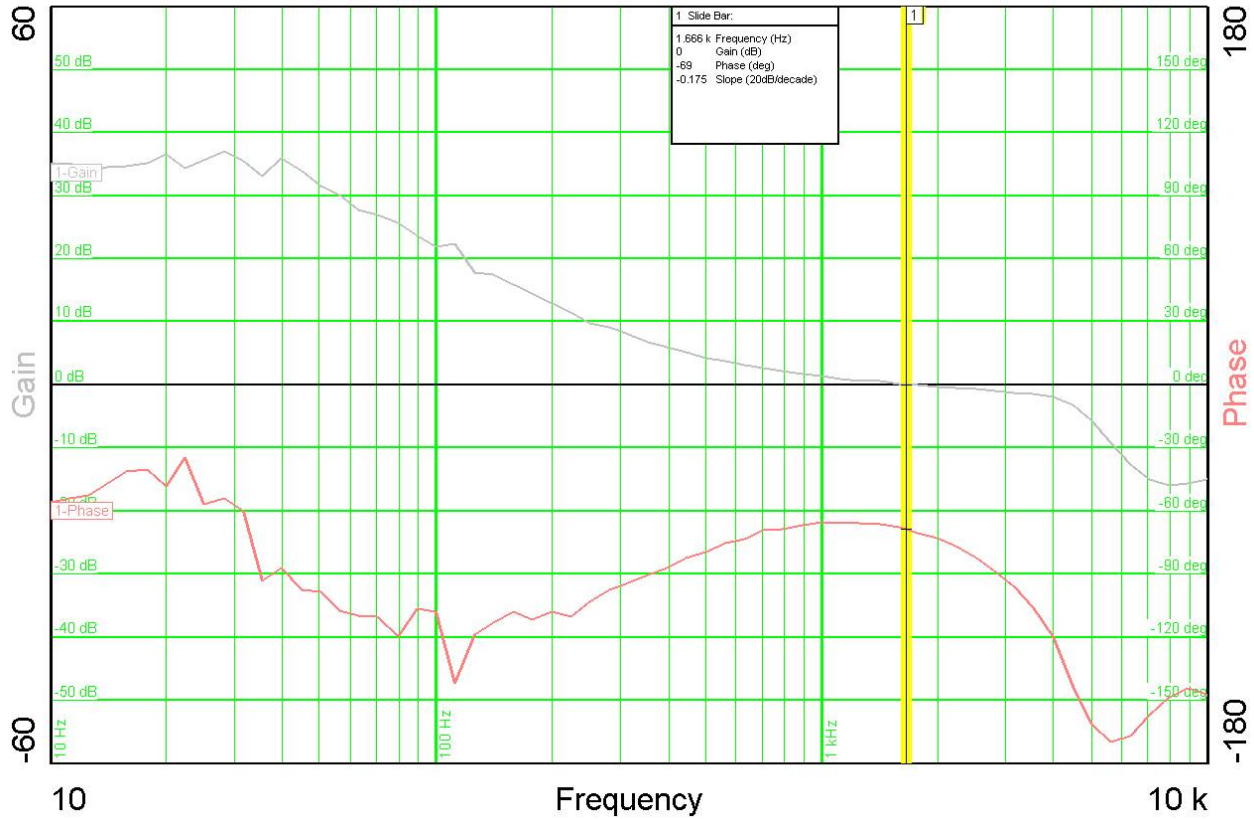

Figure 31 – Gain-Phase Plot, 90 VAC, 60 Hz, Maximum Steady State Full Load.
Crossover Frequency = 1.7 kHz, Phase Margin = 111°.



12.2 115 VAC 60 Hz Maximum Load

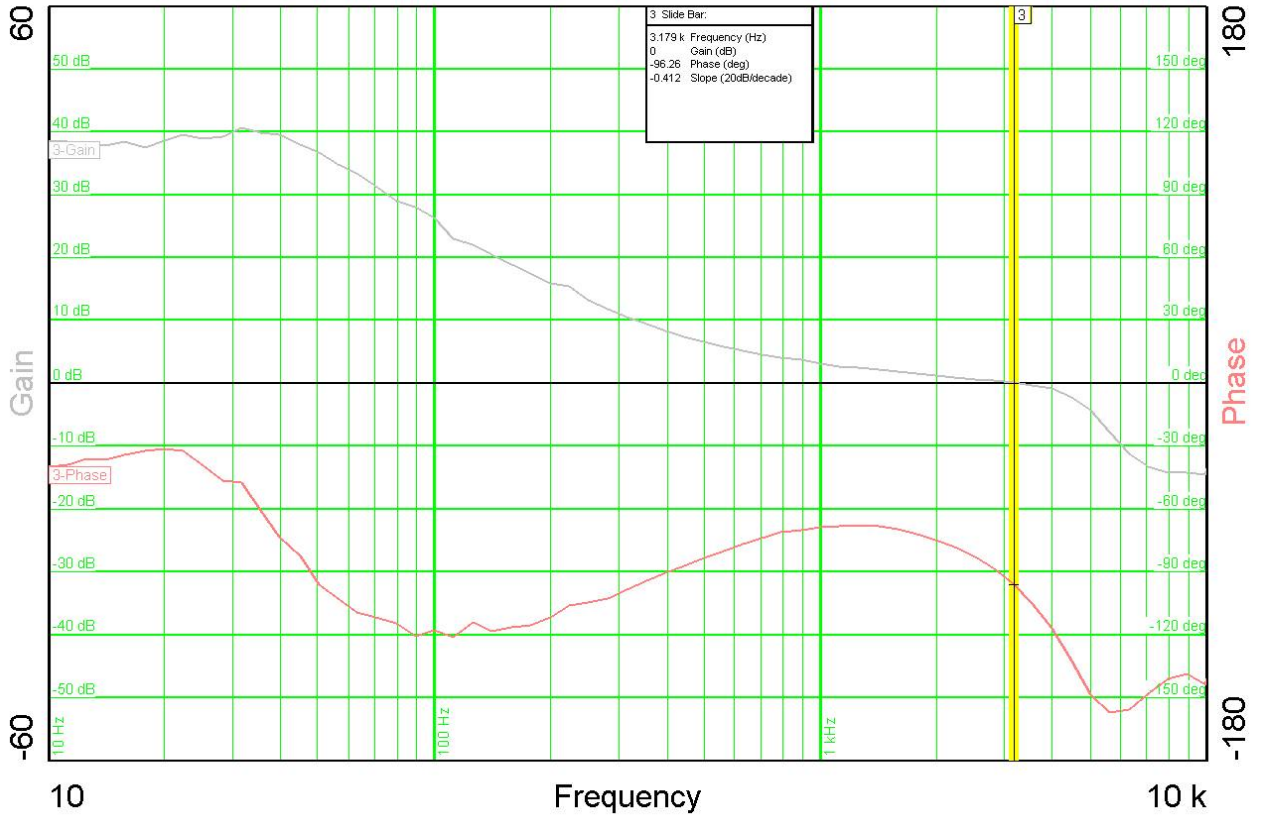

Figure 32 – Gain-Phase Plot, 115 VAC, 60 Hz, Maximum Steady State Full Load.
Crossover Frequency = 3.2 kHz, Phase Margin = 84°.



12.3 230 VAC 50 Hz Maximum Load

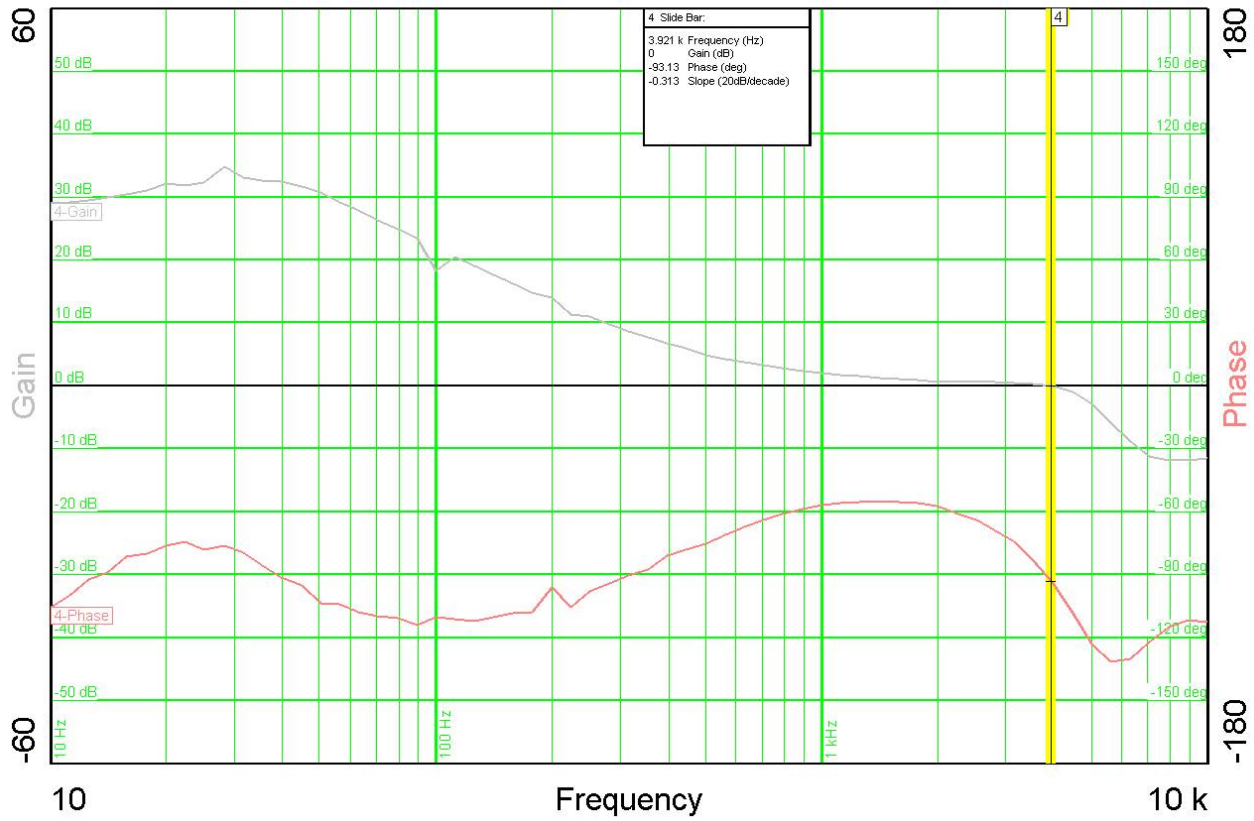

Figure 33 – Gain-Phase Plot, 230 VAC, 50 Hz, Maximum Steady State Full Load.
Crossover Frequency = 3.9 kHz, Phase Margin = 87°.



12.4 264 VAC 50 Hz Maximum Load

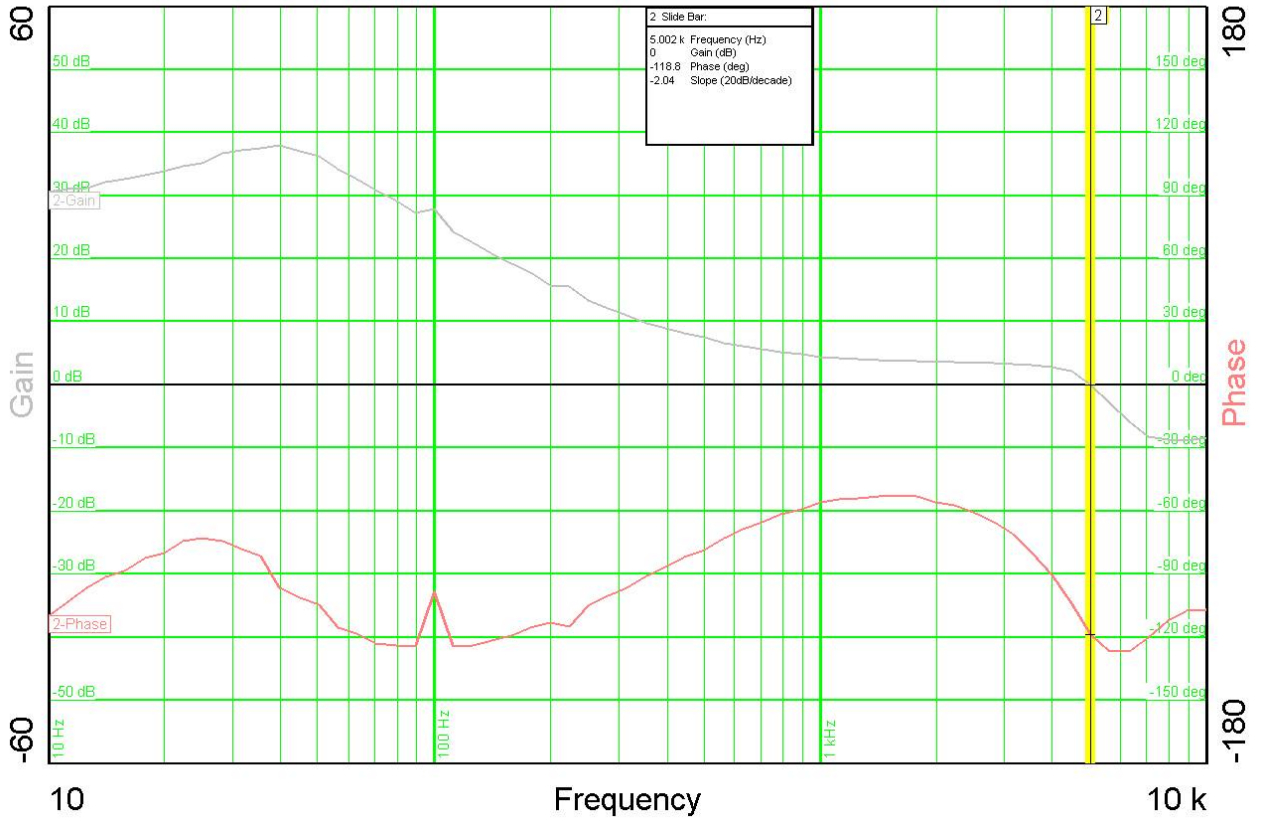

Figure 34 – Gain-Phase Plot, 264 VAC, 50 Hz, Maximum Steady State Full Load.
 Crossover Frequency = 5.0 kHz, Phase Margin = 62°.



13 Conducted EMI

Conducted EMI was measured with the board mounted above a grounded metal plate, with the output return connected to earth ground. The results below represent worst case results.

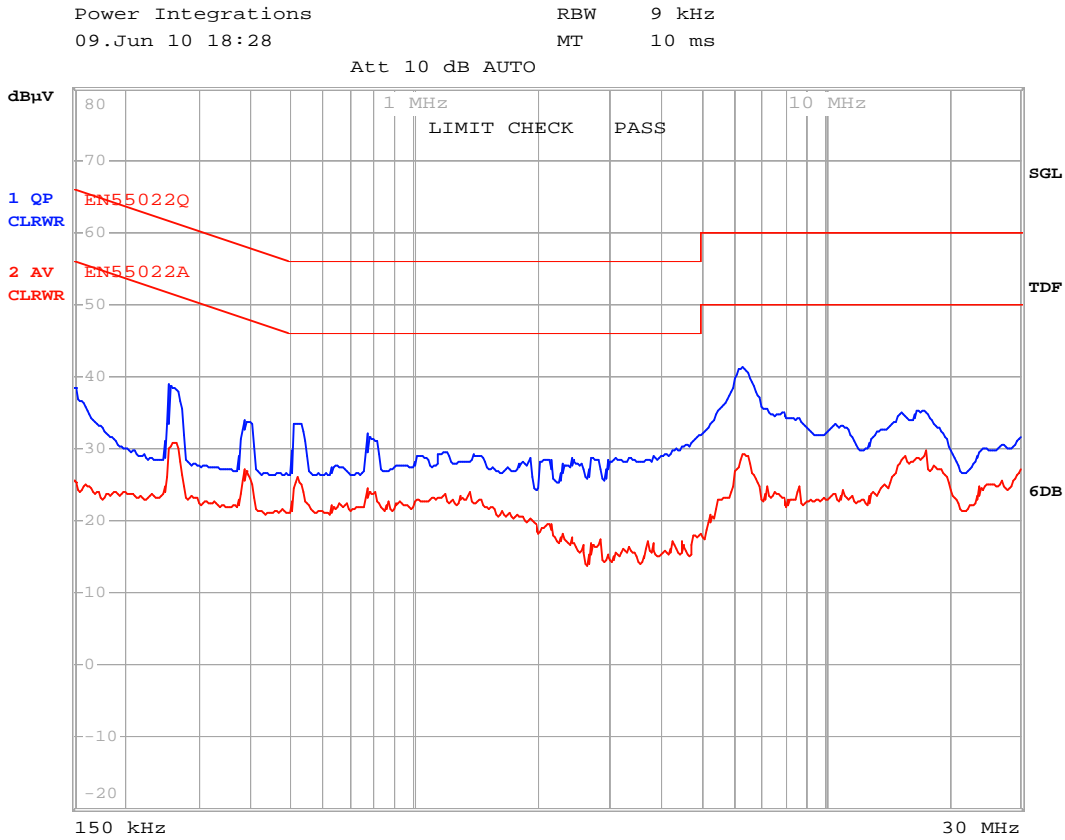

Figure 35 – Conducted EMI, Full Load, 115 VAC, 60 Hz.



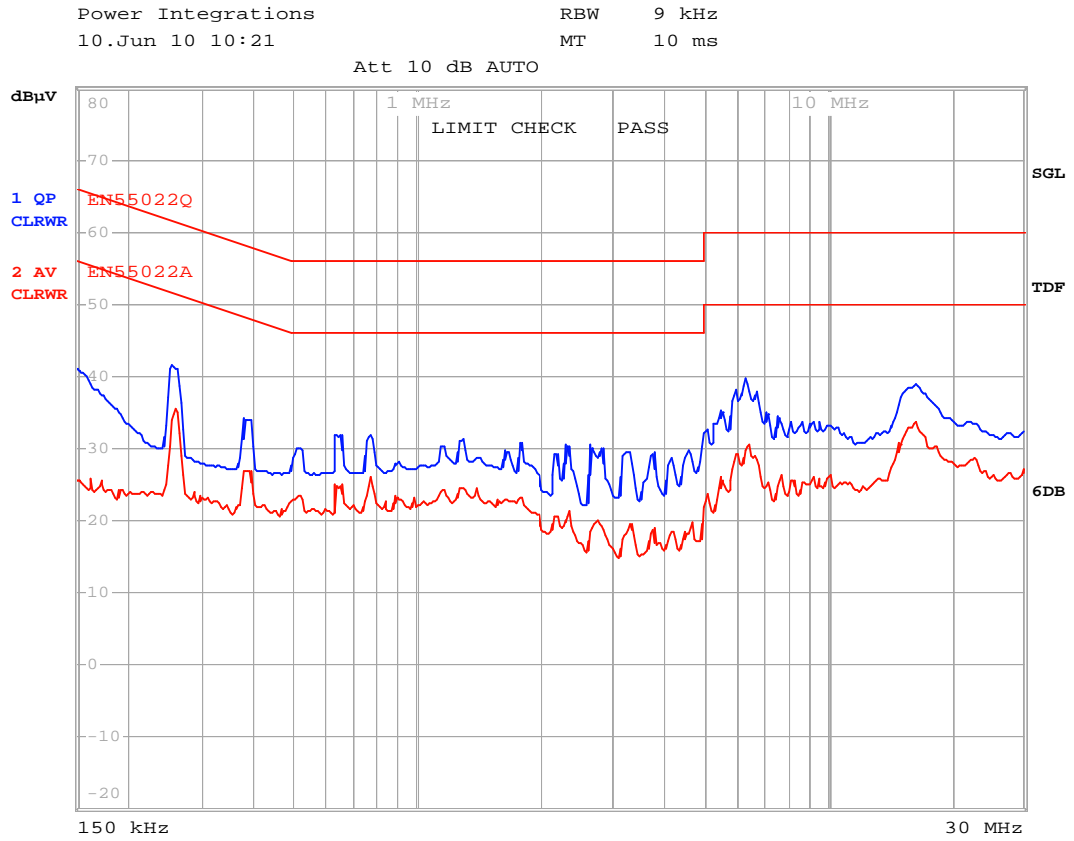

Figure 36 – Conducted EMI, Full Load, 230 VAC, 60 Hz.



14 Revision History

Date	Author	Revision	Description & changes	Reviewed
18-Aug-10	JY	1.0	Initial Release	Apps and Mktg



For the latest updates, visit our website: www.powerint.com

Power Integrations reserves the right to make changes to its products at any time to improve reliability or manufacturability. Power Integrations does not assume any liability arising from the use of any device or circuit described herein. POWER INTEGRATIONS MAKES NO WARRANTY HEREIN AND SPECIFICALLY DISCLAIMS ALL WARRANTIES INCLUDING, WITHOUT LIMITATION, THE IMPLIED WARRANTIES OF MERCHANTABILITY, FITNESS FOR A PARTICULAR PURPOSE, AND NON-INFRINGEMENT OF THIRD PARTY RIGHTS.

PATENT INFORMATION

The products and applications illustrated herein (including transformer construction and circuits external to the products) may be covered by one or more U.S. and foreign patents, or potentially by pending U.S. and foreign patent applications assigned to Power Integrations. A complete list of Power Integrations' patents may be found at www.powerint.com. Power Integrations grants its customers a license under certain patent rights as set forth at <http://www.powerint.com/ip.htm>.

The PI Logo, TOPSwitch, TinySwitch, LinkSwitch, DPA-Switch, PeakSwitch, EcoSmart, Clamless, E-Shield, Filterfuse, StackFET, PI Expert and PI FACTS are trademarks of Power Integrations, Inc. Other trademarks are property of their respective companies. ©Copyright 2010 Power Integrations, Inc.

Power Integrations Worldwide Sales Support Locations

WORLD HEADQUARTERS

5245 Hellyer Avenue
San Jose, CA 95138, USA.
Main: +1-408-414-9200
Customer Service:
Phone: +1-408-414-9665
Fax: +1-408-414-9765
e-mail:
usasales@powerint.com

GERMANY

Rueckertstrasse 3
D-80336, Munich
Germany
Phone: +49-89-5527-3911
Fax: +49-89-5527-3920
e-mail:
eurosales@powerint.com

JAPAN

Kosei Dai-3 Building
2-12-11, Shin-Yokohama,
Kohoku-ku, Yokohama-shi,
Kanagawa 222-0033
Japan
Phone: +81-45-471-1021
Fax: +81-45-471-3717
e-mail: japansales@powerint.com

TAIWAN

5F, No. 318, Nei Hu Rd., Sec. 1
Nei Hu District
Taipei 114, Taiwan R.O.C.
Phone: +886-2-2659-4570
Fax: +886-2-2659-4550
e-mail:
taiwansales@powerint.com

CHINA (SHANGHAI)

Rm 1601/1610, Tower 1
Kerry Everbright City
No. 218 Tianmu Road West
Shanghai, P.R.C. 200070
Phone: +86-021-6354-6323
Fax: +86-021-6354-6325
e-mail:
chinasales@powerint.com

INDIA

#1, 14th Main Road
Vasanthanagar
Bangalore-560052
India
Phone: +91-80-4113-8020
Fax: +91-80-4113-8023
e-mail:
indiasales@powerint.com

KOREA

RM 602, 6FL
Korea City Air Terminal B/D, 159-6
Samsung-Dong, Kangnam-Gu,
Seoul, 135-728
Korea
Phone: +82-2-2016-6610
Fax: +82-2-2016-6630
e-mail: koreasales@powerint.com

UNITED KINGDOM

1st Floor, St. James's House
East Street,
Farnham Surrey, GU9 7TJ
United Kingdom
Phone: +44 (0) 1252-730-141
Fax: +44 (0) 1252-727-689
e-mail:
eurosales@powerint.com

CHINA (SHENZHEN)

Rm A, B & C 4th Floor, Block C,
Electronics Science and
Technology Building
2070 Shennan Zhong Road
Shenzhen, Guangdong,
P.R.C. 518031
Phone: +86-755-8379-3243
Fax: +86-755-8379-5828
e-mail:
chinasales@powerint.com

ITALY

Via De Amicis 2
20091 Bresso MI
Italy
Phone: +39-028-928-6000
Fax: +39-028-928-6009
e-mail:
eurosales@powerint.com

SINGAPORE

51 Newton Road,
#15-08/10 Goldhill Plaza
Singapore, 308900
Phone: +65-6358-2160
Fax: +65-6358-2015
e-mail:
singaporesales@powerint.com

APPLICATIONS HOTLINE

World Wide +1-408-414-9660

APPLICATIONS FAX

World Wide +1-408-414-9760

