

Ferrite for Switching Power Supplies

INTRODUCTION

Our foremost mission is to develop unique and advanced electronics technologies. As such, ever since TDK was founded in 1935 when its researchers invented ferrite, we have been involved in a wide range of technological and product development efforts. Particularly, our high-performance ferrite elements, which result from our accumulated expertise and excellent microstructure control technologies, have become essential in reducing the weight and improving the performance of advanced electronic devices that are transforming the world around us.

As a result of pursuing the numerous potentials of these ferrite elements, we have been able to develop high-frequency power ferrite material that deliver among the world's highest levels of reliability and magnetic properties. These products include PC33, PC40, PC44, PC45, PC46, PC47, and PC50. They contribute to achieving even greater size reductions and performance improvements of high-performance switching power supplies and DC to DC converters -- products considered to constitute the heart of microelectronic devices. We have also developed the PC95, which delivers a saturated magnetic flux density equivalent to that of PC44 and low loss in a wide temperature range. This materials is expected to improve the efficiency of power supplies in DC to DC converters used in electric vehicles.

Additionally, we have been conducting research in ferrite that delivers permeability close to the theoretical limit in high frequency ranges. These ferrite materials are designed for EMC solutions. The materials HS52, HS72, and HS10 deliver frequency responses with excellent permeability - a prerequisite for EMC magnetic material such as EMI filters and common mode choke coils - and higher impedance compared to existing material in the high frequency ranges.

In parallel with material development, we have been working to reduce sizes and improve the performance of our switching power supplies and DC to DC converters. To this end, we have been developing optimum core shape designs and creating an extensive line up of these products to accommodate a wide range of specific needs. We also manufacture peripheral items including bobbins and various accessories.

CIRCUIT EXAMPLE

SINGLE FORWARD CONVERTER

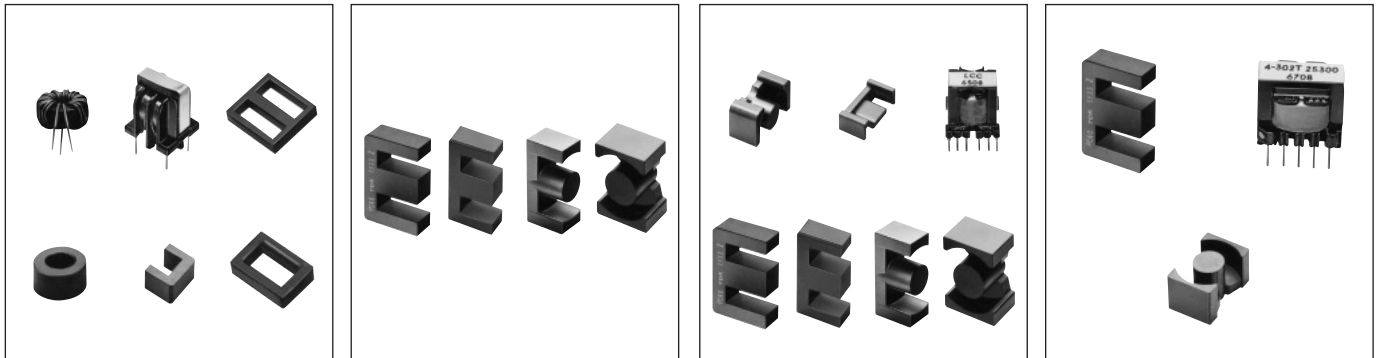

Common mode choke coil

Active filter choke coil

Main power transformer

Smoothing choke coil

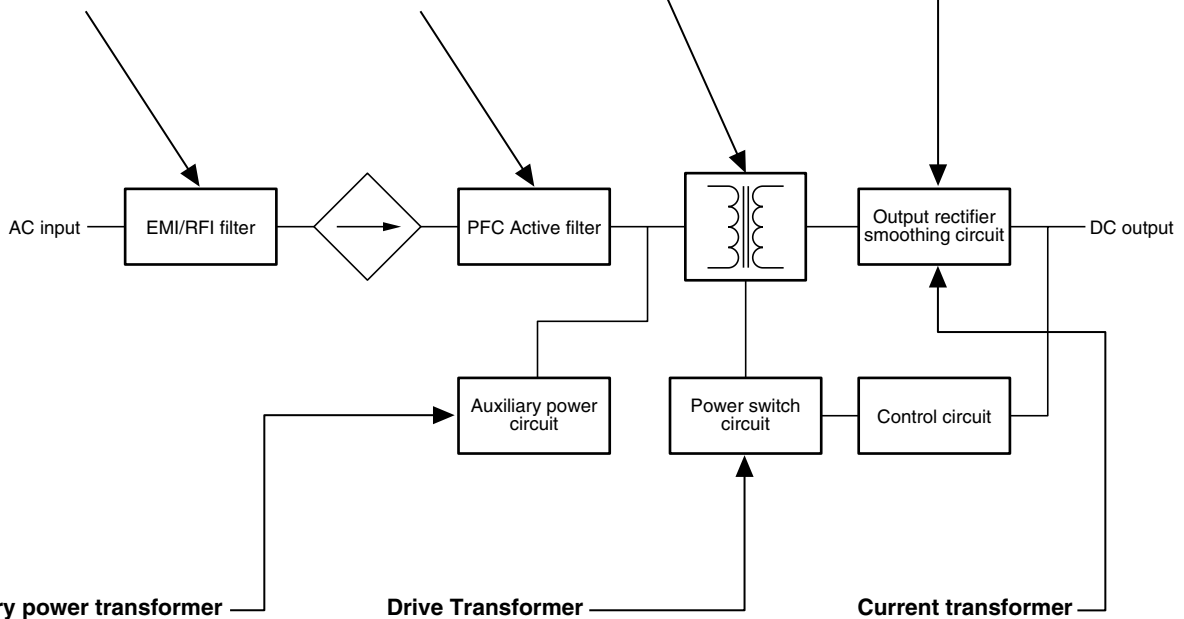

Auxiliary power transformer

Drive Transformer

Current transformer

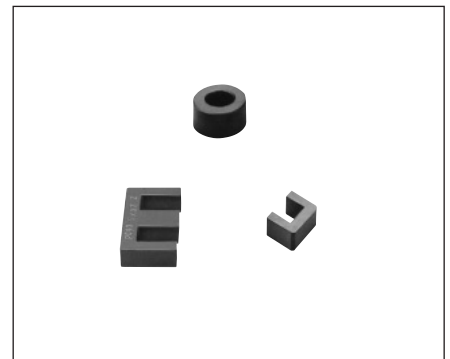
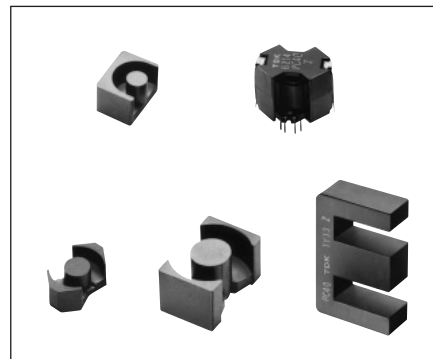
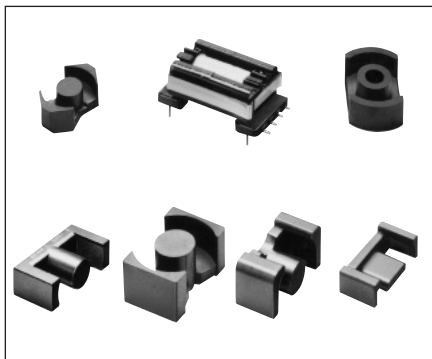

- Notes:
- LP and EPC cores are ideal for use in thin transformers.
 - LP cores are available in .5 and .7 inches in height (when mounted).
 - EP cores are available in .5 and .65 inches in height (when mounted).

SELECTED ITEMS OF LEGEND

$C_1 = \sum \frac{\ell}{A}$	Core constant mm ⁻¹
Ae	Effective cross-sectional area, mm ²
ℓ_e	Effective magnetic path length, mm
Ve	Effective core volume mm ³
Acp	Cross-sectional center leg/pole area, mm ²
Acp min.	Minimum cross-sectional center pole area, mm ²
Acw	Cross-sectional winding area of core, mm ²
Aw	Cross-sectional winding area of bobbin, mm ²
ℓ_w	Average length of turns around bobbin, mm
t	Minimum thickness of bobbin inside which core is placed, including flanges, mm
W	Bobbin-core assembly dimensions
D	Bobbin-core assembly dimensions
H	Bobbin-core assembly dimensions

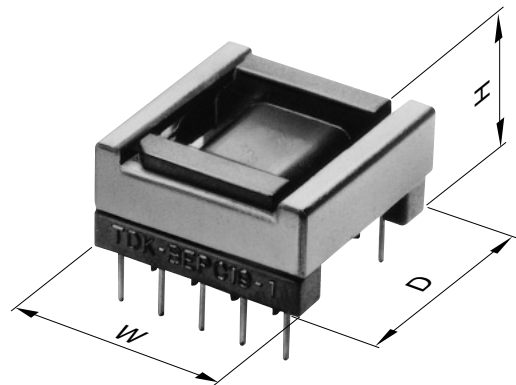
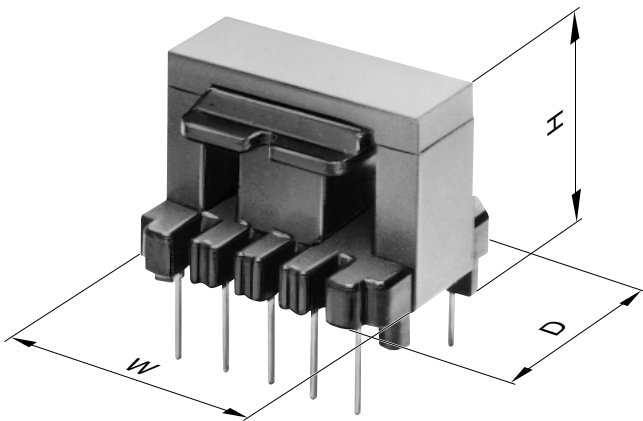

MATERIAL CHARACTERISTICS

MATERIAL CHARACTERISTICS

For Transformer and Choke

Material				PC40	PC44	PC47	PC50	
Initial permeability	μ i			2300±25%	2400±25%	2500±25%	1400±25%	
Amplitude permeability	μ a			3000 min.	3000 min.			
Core loss volume density (Core loss)* [B=200mT]	Pcv	kW/m ³	25kHz sine wave	25°C				
				60°C	120			
				100°C	80			
				120°C	70			
			100kHz sine wave	25°C	600	600	600	130**
				60°C	450	400	400	80**
				100°C	410	300	250	80**
				120°C	500	380	360	110**
Saturation magnetic flux density* [H=1194A/m]	Bs	mT	25°C	510	510	530	470	
			60°C	450	450	480	440	
			100°C	390	390	420	380	
			120°C	350	350	390	350	
Remanent flux density*	Br	mT	25°C	95	110	180	140	
			60°C	65	70	100	110	
			100°C	55	60	60	98	
			120°C	50	55	60	100	
Coercive force*	Hc	A/m	25°C	14.3	13	13	36.5	
			60°C	10.3	9	9	31.0	
			100°C	8.8	6.5	6	27.2	
			120°C	8	6	7	26.0	
Curie temperature	Tc	°C		>215	>215	>230	>240	
Density*	db	kg/m ³		4.8×10 ³	4.8×10 ³	4.9×10 ³	4.8×10 ³	
Electrical resistivity*	ρ v	$\Omega \cdot m$		6.5	6.5	4.0	30	

Material				PC45	PC46	PC33	PC95	
Initial permeability	μ i			2500±25%	3200±25%	1400±25%	3300±25%	
Amplitude permeability	μ a							
Core loss volume density (Core loss)* [B=200mT]	Pcv	kW/m ³	100kHz sine wave	25°C	570	350	1100	350
				60°C	250(75°C)	250(45°C)	800	
				100°C	460	660	600	290
				120°C	650	760	680	350
Saturation magnetic flux density* [H=1194A/m]	Bs	mT	25°C	530	520	510	530	
			60°C	480	470	490	480	
			100°C	420	410	440	410	
			120°C	390	380	420	380	
Remanent flux density*	Br	mT	25°C	120	80	220	85	
			60°C	80	80	150	70	
			100°C	80	130	100	60	
			120°C	110	140	100	55	
Coercive force*	Hc	A/m	25°C	12	10	23	9.5	
			60°C	9	9	17	7.5	
			100°C	8	10	14	6.5	
			120°C	9	9	14	6.0	
Curie temperature	Tc	°C		>230	>230	>290	>215	
Density*	db	kg/m ³		4.8×10 ³	4.8×10 ³	4.8×10 ³	4.9×10 ³	
Electrical resistivity*	ρ v	$\Omega \cdot m$		3.0	3.0	2.5	6.0	

* Average value

** 500kHz, 50mT

For Common Mode Choke

Material				HS52	HS72	HS10
Initial permeability	μ			5500±25%	7500±25% (2000min. at 500kHz)	10000±25%
Relative loss factor*	$\tan\delta/\mu$	$\times 10^{-6}$		10(100kHz)	30(100kHz)	30(100kHz)
Saturation magnetic flux density* [H=1194A/m]	Bs	mT	25°C	410	410	380
Remanent flux density*	Br	mT	25°C	70	80	120
Coercive force*	Hc	A/m	25°C	6	6	5
Curie temperature	Tc	°C		>130	>130	>120
Density*	db	kg/m ³		4.9×10 ³	4.9×10 ³	4.9×10 ³
Electrical resistivity*	ρv	$\Omega \cdot m$		1	0.2	0.2

For Telecommunication

Material				H5A	H5B2	H5C2	H5C3
Initial permeability	μ			3300 ^{+40%} _{-0%}	7500±25%	10000±30%	15000±30%
Relative loss factor	$\tan\delta/\mu$	$\times 10^{-6}$		<2.5(10kHz) <10(100kHz)	<6.5(10kHz)	<7.0(10kHz)	<7.0(10kHz)
Temperature factor of initial permeability	$\alpha_{\mu ir}$	$\times 10^{-6}$	-30 to +20°C	-0.5 to 2.0	0 to 1.8	-0.5 to 1.5	-0.5 to 1.5
			0 to 20°C				
			20 to 70°C	-0.5 to 2.0	0 to 1.8	-0.5 to 1.5	-0.5 to 1.5
Saturation magnetic flux density* [H=1194A/m]	Bs	mT	25°C	410	420	400	360
Remanent flux density*	Br	mT	25°C	100	40	90	105
Coercive force*	Hc	A/m	25°C	8.0	5.6	7.2	4.4
Curie temperature	Tc	°C		>130	>130	>120	>105
Hysteresis material constant	η_B	$\frac{10^{-6}}{mT}$		<0.8	<1.0	<1.4	<0.5
Disaccommodation factor	D _F	$\times 10^{-6}$		<3	<3	<2	<2
Density*	db	kg/m ³		4.8×10 ³	4.9×10 ³	4.9×10 ³	4.95×10 ³
Electrical resistivity*	ρv	$\Omega \cdot m$		1	0.1	0.15	0.15

Material				HP5	DNW45	DN45	DN40	DN70
Initial permeability	μ			5000±20%	4200±25%	4500±25%	4000±25%	7500±25%
Relative loss factor	$\tan\delta/\mu$	$\times 10^{-6}$	25°C, 10kHz	<3.5	<3.5	<3.5	<2.5	<2.0
Temperature factor of initial permeability	$\alpha_{\mu ir}$	$\times 10^{-6}$	-30 to +20°C				-0.5 to 2.0	-0.5 to 1.5
			0 to 20°C	±12.5%				
			20 to 70°C	±12.5%			-0.5 to 2.0	-0.5 to 1.5
Saturation magnetic flux density* [H=1194A/m]	Bs	mT	25°C	400	450	460	405	390
Remanent flux density*	Br	mT	25°C	65	50	50	95	45
Coercive force*	Hc	A/m	25°C	7.2	6.5	6	8.0	3.5
Curie temperature	Tc	°C		>140	>150	>150	>130	>105
Hysteresis material constant	η_B	$\frac{10^{-6}}{mT}$		<0.4	<0.8	<0.4	<0.8	<0.2
Disaccommodation factor	D _F	$\times 10^{-6}$		<3	<3	<3	<3	<2.5
Density*	db	kg/m ³		4.8×10 ³	4.85×10 ³	4.85×10 ³	4.8×10 ³	5.0×10 ³
Electrical resistivity*	ρv	$\Omega \cdot m$		0.15	0.65	0.3	1.0	0.3

* Average value

μ vs. Frequency Characteristics

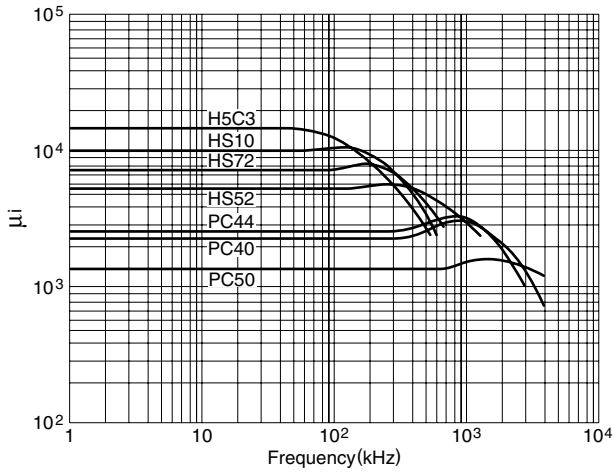

$\tan \delta / \mu$ vs. Frequency Characteristics

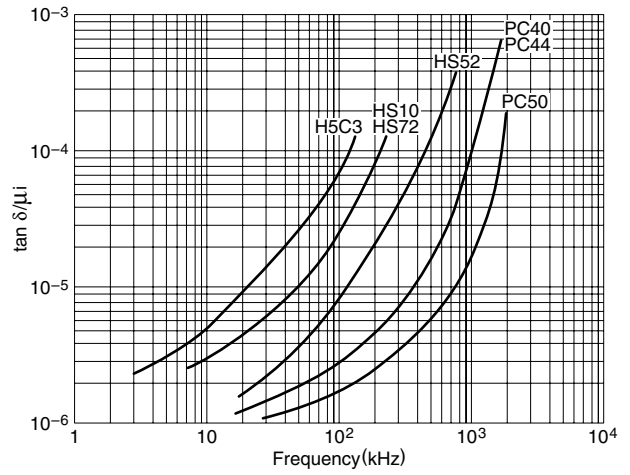

Magnetization Curves (Typical)

Material: PC40

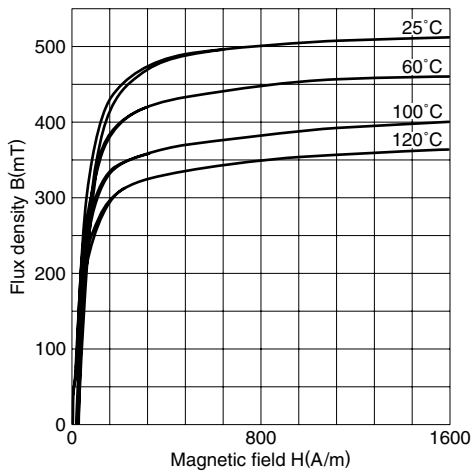

Material: PC44

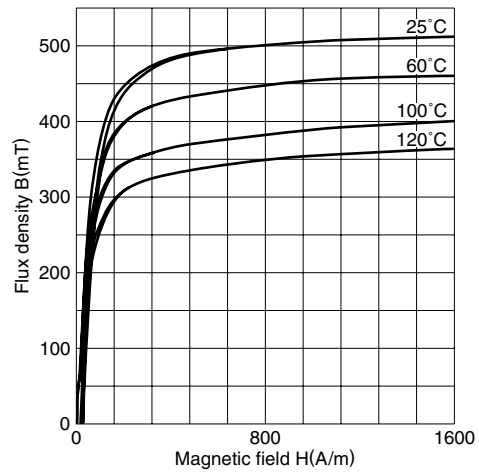

Material: PC50

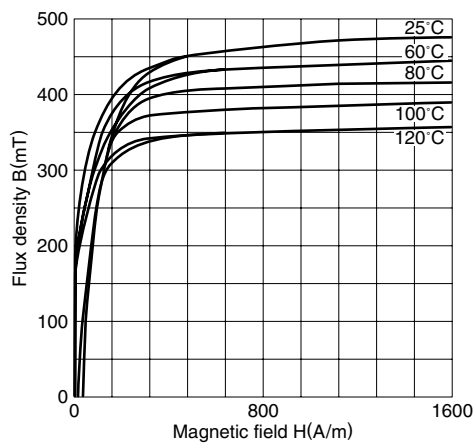

Core Loss (Typical)

Material: PC40

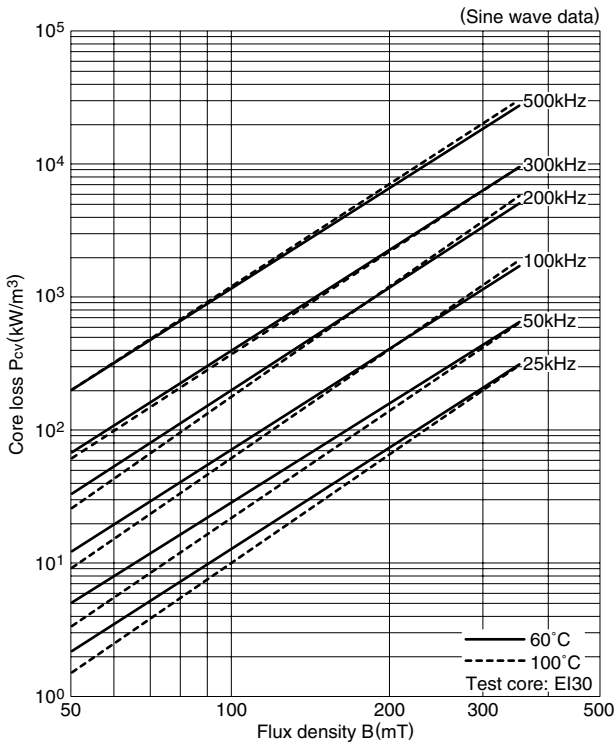

Material: PC44

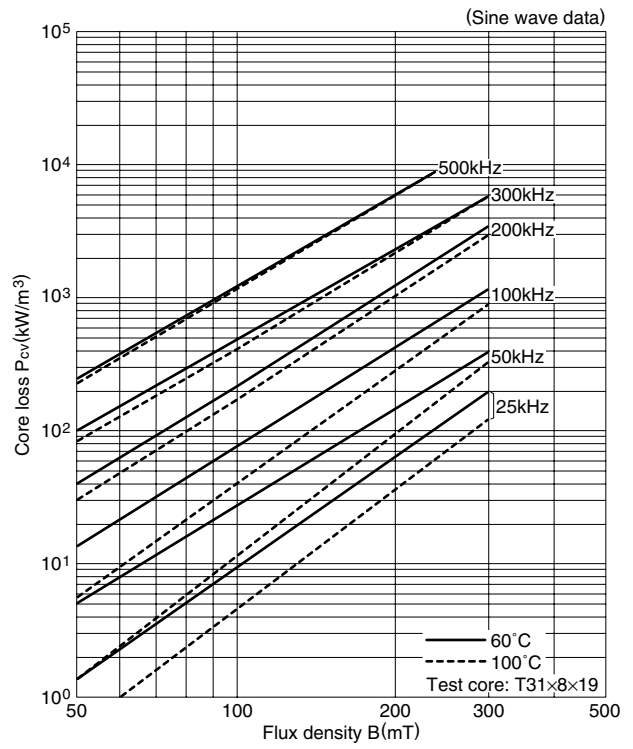

Material: PC50

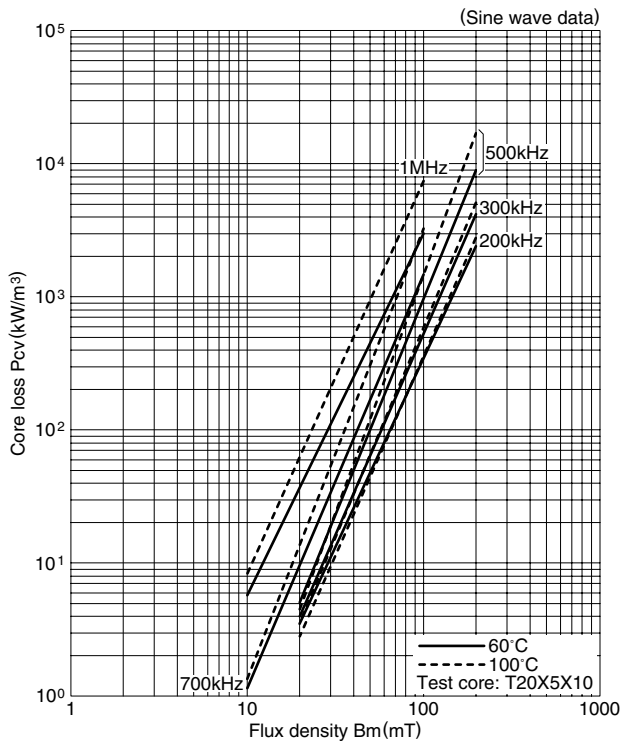

• All specifications are subject to change without notice.

Temperature Dependence of Core Loss (Typical)

Material: PC40 (Frequency: 100kHz)

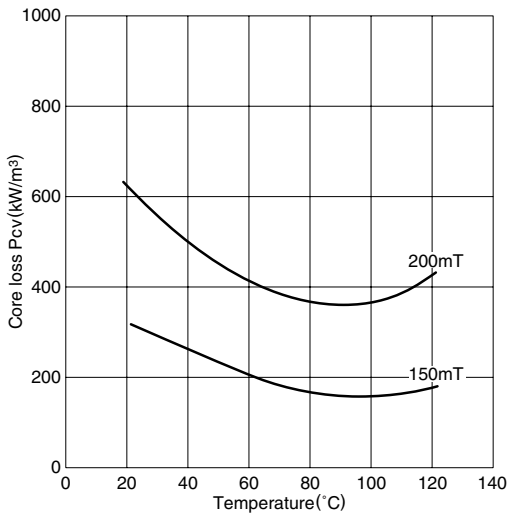

Material: PC44 (Frequency: 100kHz)

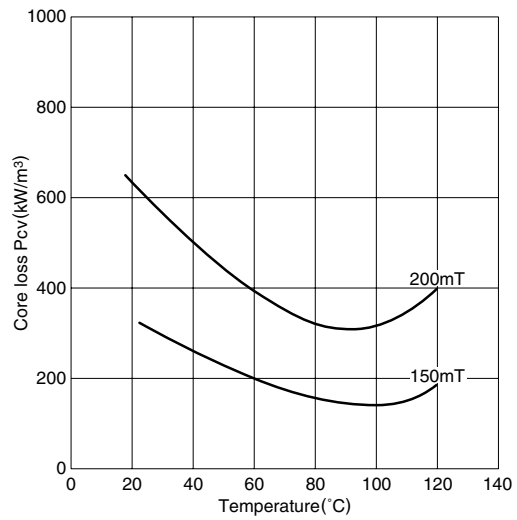

Test core: Toroidal
OD=31mm
TH=8mm
ID=19mm

Material: PC50

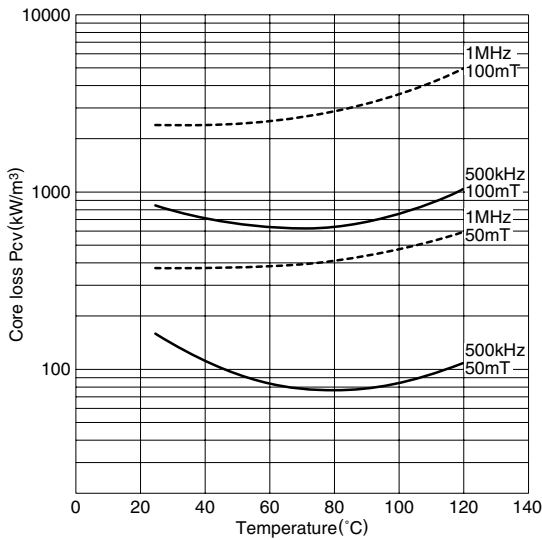

Magnetization Curves (Typical)

HS52

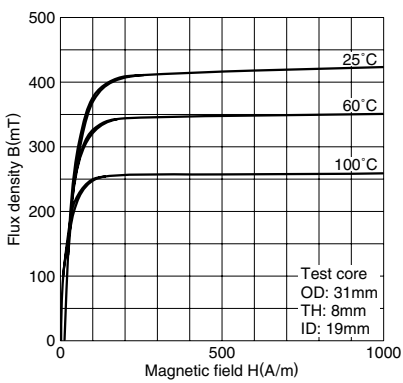

HS72

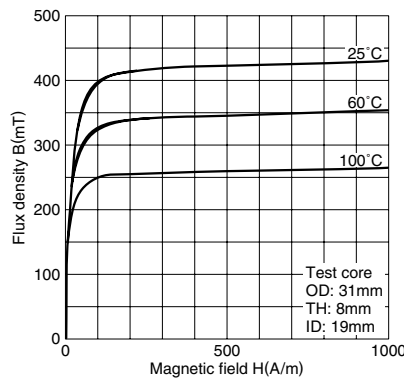

HS10

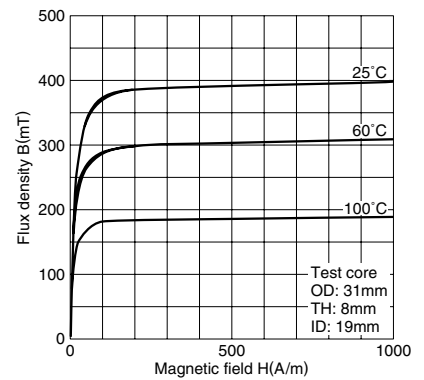

μi vs. Temperature Characteristics (Typical)

PC40

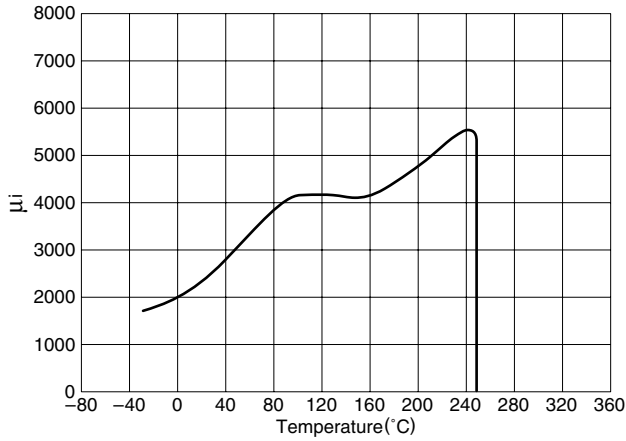

HS52

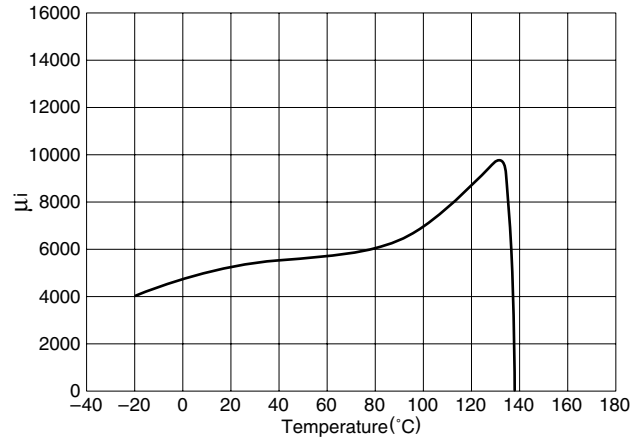

PC44

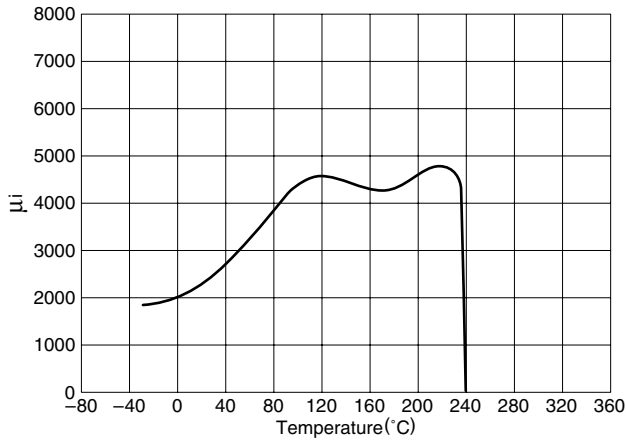

HS72

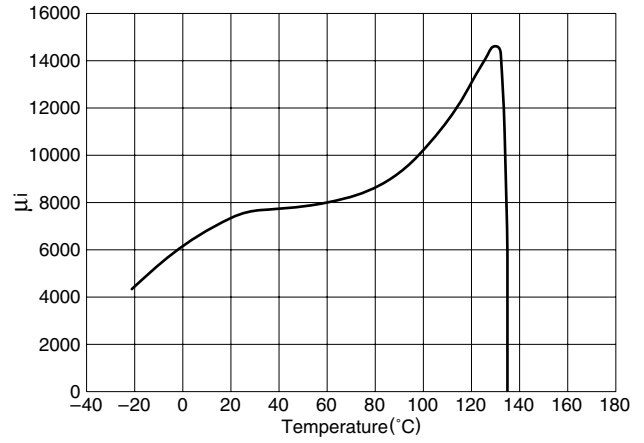

PC50

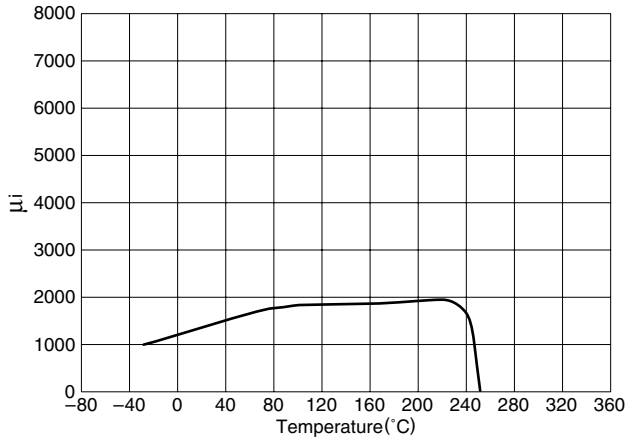

HS10

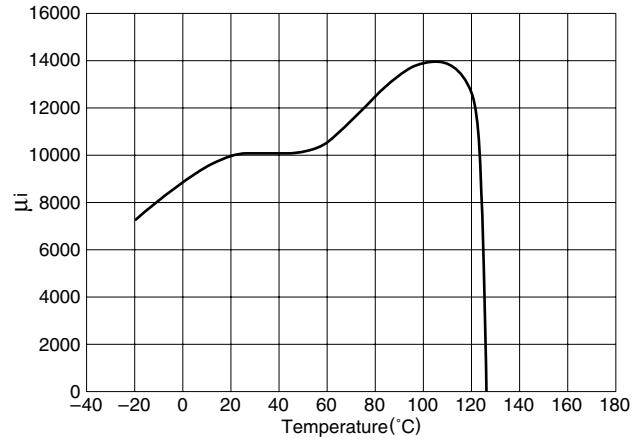

Test core: OD=31mm
TH=8mm
ID=19mm

WIDE TEMPERATURE RANGE, LOW LOSS POWER MATERIAL PC95

Based on TDK's ferrite technologies, PC95 is a high-performance ferrite material that achieves low loss over a wide range of temperatures.

This material delivers the same level of saturated magnetic flux density as our existing PC44 and also delivers minimal loss (under 350kW/m^3) at temperatures ranging from 25 to 120°C .

PC95 can be used at a near-optimum state regardless of temperature. Owing to this characteristic, transformers based on the material PC95 are optimally suited for use in DC to DC converters in electric vehicle applications, such as HEVs and FCEVs, in which components are exposed to a wide range of temperatures. It can also be used in switching power supply transformers.

FEATURES

- Low loss: $<350\text{kW/m}^3$ (100kHz, 200mT) from 25 to 120°C .
- If used in DC to DC converters for electric vehicles, fuel efficiency can be improved due to the improved power efficiency over a wide temperature ranges.
- The materials offer about the same saturation magnetic flux density as PC44 from room temperature up to high temperatures.
- The materials can be shaped into standard as well as original shapes.

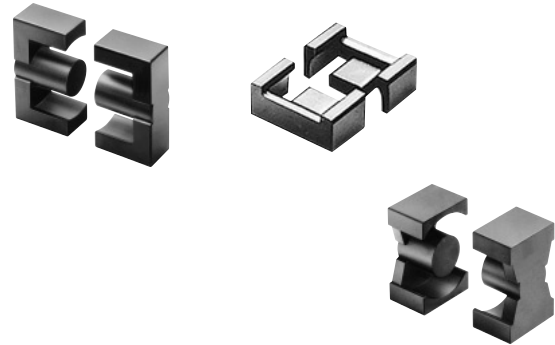

APPLICATIONS

- DC to DC converters for automobiles
- Main transformers for various switching power supplies
- Inverter transformers for LCD backlight
- AC adapters and chargers

MATERIAL CHARACTERISTICS

Material	PC95(NEW)		PC44
	25°C	350	
Core loss P _{cv} kW/m ³ [100kHz, 200mT]	80°C	280	320
	120°C	350	400

CORE LOSS vs. TEMPERATURE CHARACTERISTICS

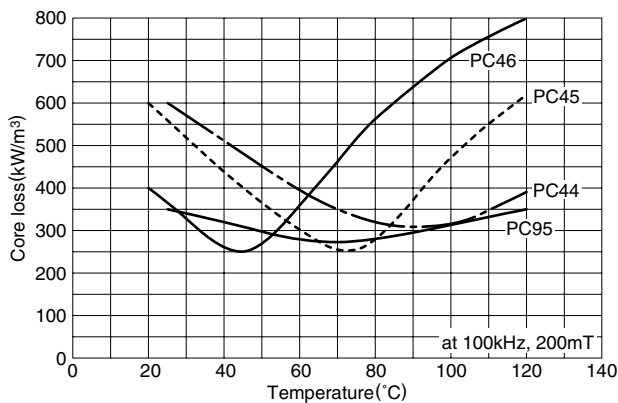

LOW LOSS FERRITE MATERIAL PC47

PC47 has the best properties for transformers of power supplies, adapters and chargers.

The core loss and saturation magnetic flux density of PC47 are far better than PC44 and PC40 which are currently in use.

FEATURES

- Core loss: 250kW/m³ at 100kHz, 200mT, 100°C.
- Low core loss at wide frequency range 100kHz to 300kHz.
- Higher saturation flux density than PC44.

APPLICATIONS

- Switching power supplies
- Adapters and chargers for notebook type pc
- CCFL LCD backlight

MATERIAL CHARACTERISTICS

Material			PC47(NEW)	PC44	PC40
Initial permeability	μ	25°C	2500±25%	2400±25%	2300±25%
Core loss volume density [100kHz, 200mT]	P _{cv}	25°C	600	600	600
		60°C	400	400	450
		100°C	250	300	410
Saturation magnetic flux density [1000A/m]	B _s	25°C	530	510	510
		100°C	420	390	390
Remanent flux density	B _r	25°C	180	110	95
		100°C	60	60	55
Curie temperature	T _c	°C	min. 230	215	215
Density	db	kg/m ³	4.9×10 ³	4.8×10 ³	4.8×10 ³

P_{cv} TEMPERATURE DEPENDENCE CHARACTERISTICS (Typical)

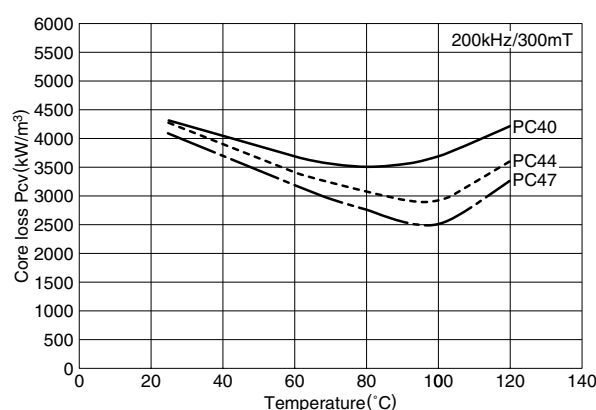
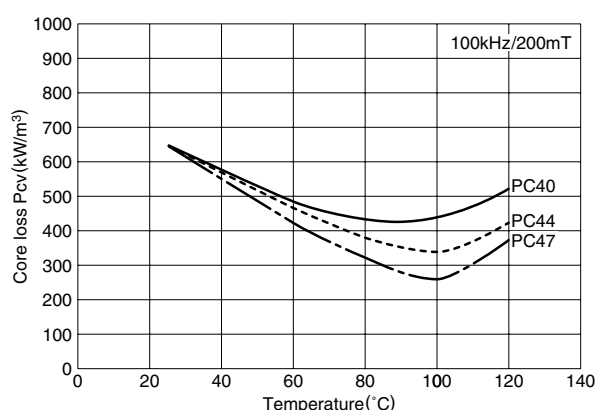

B_s and B_r TEMPERATURE DEPENDENCE CHARACTERISTICS (Typical)

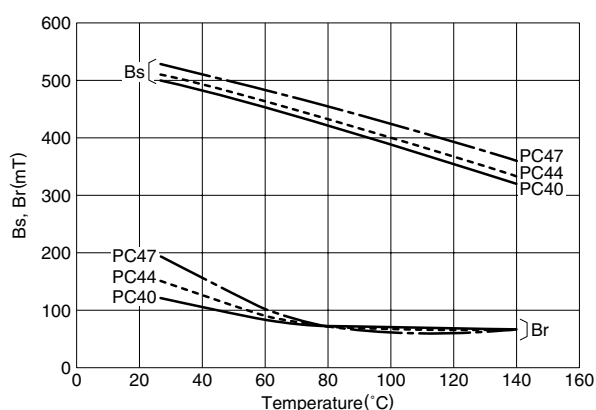

μ_i vs. FREQUENCY CHARACTERISTICS (Typical)

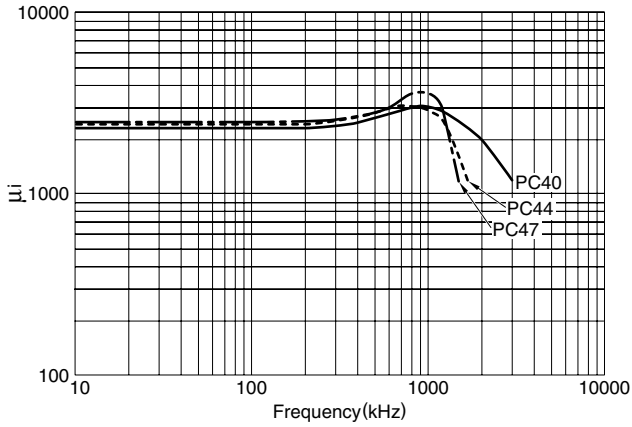

μ_i vs. TEMPERATURE CHARACTERISTICS (Typical)

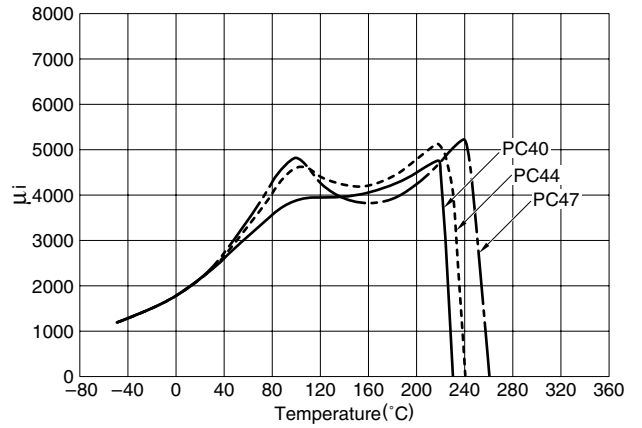

MAGNETIZATION CURVES (Typical)

MATERIAL:PC47

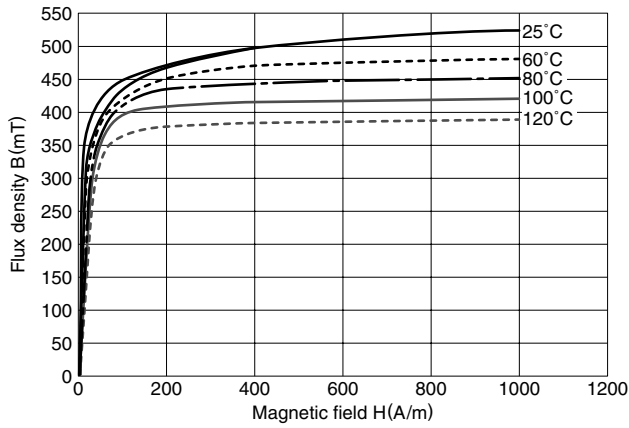

μ_a TEMPERATURE DEPENDENCE CHARACTERISTICS

(Typical)

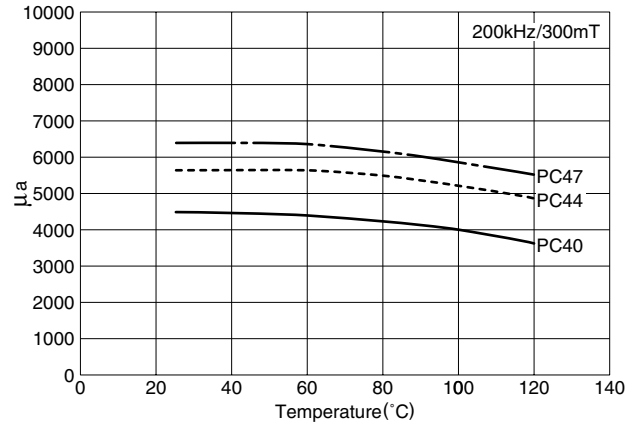

• All specifications are subject to change without notice.

LOW LOSS FERRITE MATERIALS PC45 AND PC46

In recent years, with the advent of notebook type pc, VCR's, digital camera's and mobile communication devices, technological demands have risen for higher performance CCFL LCD backlight units that have smaller sizes, lower profiles and higher efficiency.

The PC45 and PC46 are materials developed to achieve higher efficiency in designing minimize core loss at practical temperature ranges (PC45: 60 to 80°C and PC46: 40 to 50°C) and high saturation flux density.

They are also suitable for the transformers of DC to DC converters and adapters of notebook type pc.

APPLICATIONS

- Switching power supplies
- Adapters and chargers for notebook type pc
- CCFL LCD backlight

MATERIAL CHARACTERISTICS

Material			PC45(NEW)	PC46(NEW)	PC44
Initial permeability	μ_i	25°C	2500±25%	3200±25%	2400±25%
		25°C	570	350	600
Core loss volume density [100kHz, 200mT]	P _{cv}	60°C	250(75°C)	250(45°C)	400
		100°C	460	660	300
		100°C	460	660	300
Saturation magnetic flux density [1000A/m]	B _s	25°C	530	530	510
		100°C	420	410	390
Remanent flux density	B _r	25°C	120	80	110
		100°C	80	115	60
Curie temperature	T _c	°C	min. 230	230	215
Density	db	kg/m ³	4.8×10 ³	4.8×10 ³	4.8×10 ³

P_{cv} TEMPERATURE DEPENDENCE CHARACTERISTICS (Typical)

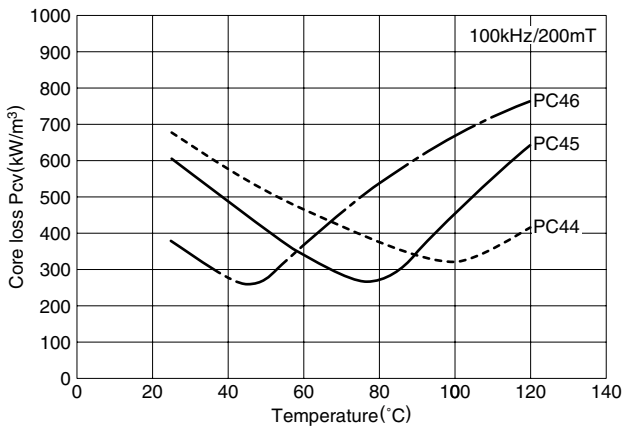

B_s and B_r TEMPERATURE DEPENDENCE CHARACTERISTICS (Typical)

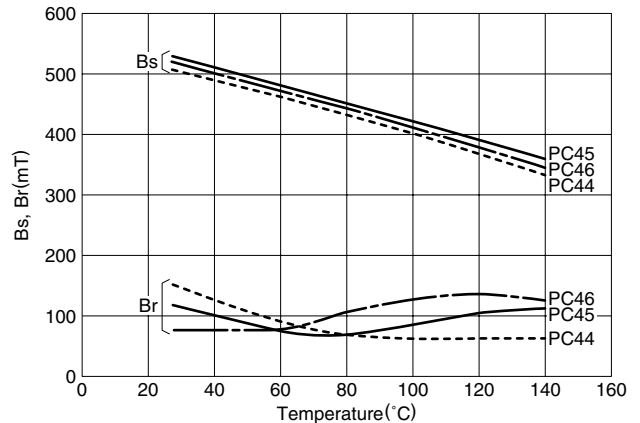

μ_i vs. FREQUENCY CHARACTERISTICS (Typical)

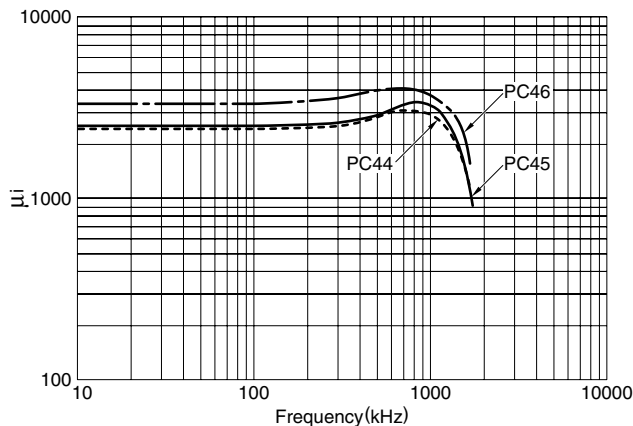

μ_i vs. TEMPERATURE CHARACTERISTICS (Typical)

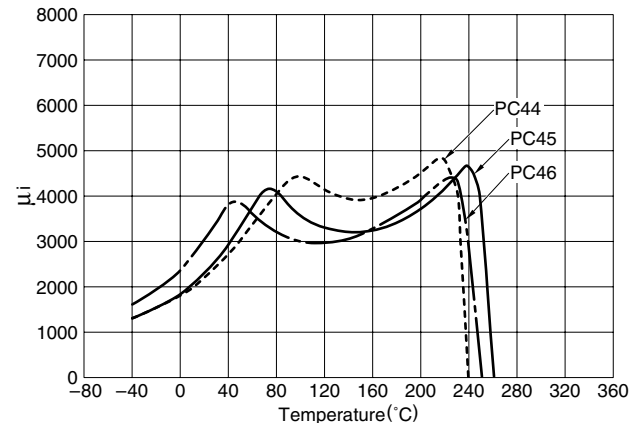

MAGNETIZATION CURVES

MATERIAL:PC45

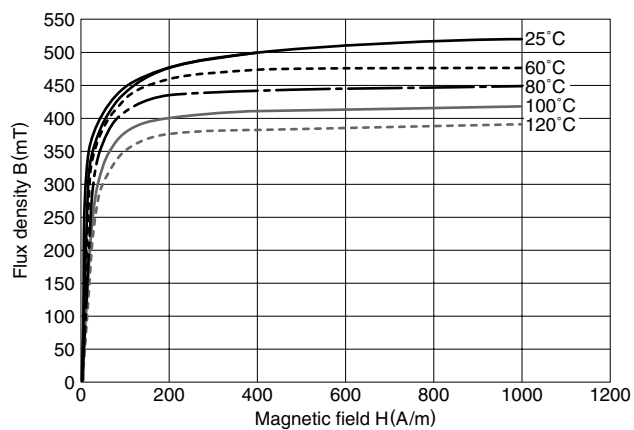

MATERIAL:PC46

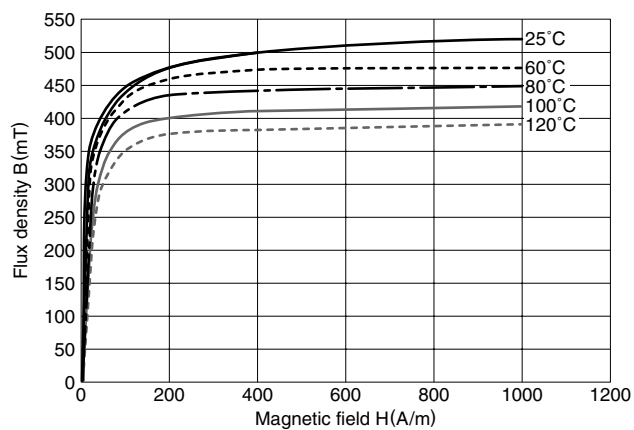

HIGH SATURATION FLUX DENSITY MATERIAL FOR CHOKE COIL PC33

PC33 has the best properties for smoothing choke coil of power supplies.

The saturation magnetic flux density of PC33 is far better than PC44 and PC40 which are currently in use.

FEATURES

- Higher saturation flux density than PC44 and PC40.
- Most suitable ferrite material for choke coils.
- Maintain high saturation magnetic flux density at high temperature.

APPLICATIONS

- Power choke coils for switching power supplies
- Power choke coils for notebook type pc

MATERIAL CHARACTERISTICS

Material				PC33(NEW)	PC44	PC40
Saturation magnetic flux density [1000A/m]	Bs	mT	25°C	510	510	510
			100°C	440	390	390
Initial permeability	μ		25°C	1400±25%	2400±25%	2300±25%
Core loss volume density [100kHz, 200mT]	P _{cv}	kW/m ³	25°C	1100	600	600
			60°C	800	400	450
			100°C	600	300	410
Curie temperature	T _c	°C	min.	290	215	215
Density	db	kg/m ³		4.8×10 ³	4.8×10 ³	4.8×10 ³

P_{cv} TEMPERATURE DEPENDENCE CHARACTERISTICS (Typical)

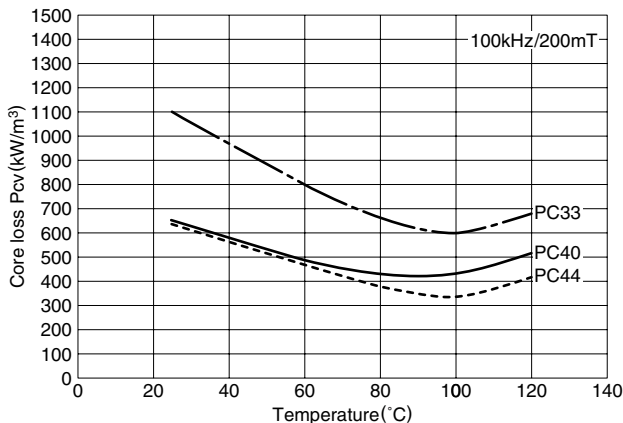

B_s TEMPERATURE DEPENDENCE CHARACTERISTICS (Typical)

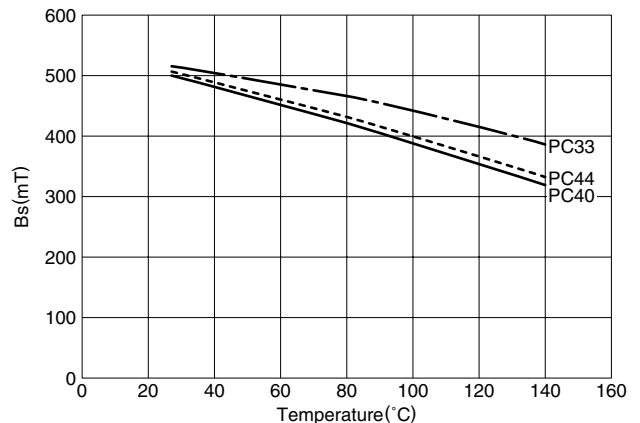

FERRITE MATERIALS FOR LAN PULSE TRANSFORMERS DNW45

With the growing popularity of high-speed Ethernet, the demand for ferrite material that is optimally suited for pulse transformers in LAN systems is rising. In particular, LAN systems that are subjected to the harsh operating environments found in industrial applications are required to operate at wider temperature ranges compared to existing materials.

To meet such demands, TDK has developed the DNW45, a product dedicated to small toroidal forms used in high-speed LANs, which delivers high inductance and excellent DC superposition characteristics at a wide temperature range (−40 to +85°C).

FEATURES

- Delivers high inductance over a wide temperature range (−40 to +85°C).
- This ferrite material delivers excellent DC superposition characteristics and was designed for small toroidal cores.
- DC superposition characteristics in the −40 to +85°C temperature range has been improved by 23% compared to DN45, one of previous materials.

APPLICATIONS

Ferrite core for pulse transformers in Ethernet (100Base-T) LAN systems.

- Please consult us for on-vehicle applications.

MATERIAL CHARACTERISTICS

COMPARISON TO PREVIOUS MATERIAL

Material				DNW45(NEW)	DN45	HP5
Initial permeability	μ_i		25°C	4200±25%	4500±25%	5000±25%
Relative loss factor	$\tan\delta/\mu_i$	$\times 10^{-6}$	25°C, 10kHz	<3.5	<3.5	<3.5
Saturation magnetic flux density	B_s	mT	25°C, 1000A/m	450	460	400
Curie temperature	T_c	°C	min.	150	150	140
Density	db	kg/m ³		4.85×10^3	4.85×10^3	4.8×10^3
Electrical resistivity	ρ_v	$\Omega \cdot m$	25°C	0.65	0.3	0.15

- Measured with toroidal core(OD10×ID5×T2.5mm).

- Various toroidal cores of small sizes are available. Please contact us for details.

μ_i vs. TEMPERATURE CHARACTERISTICS

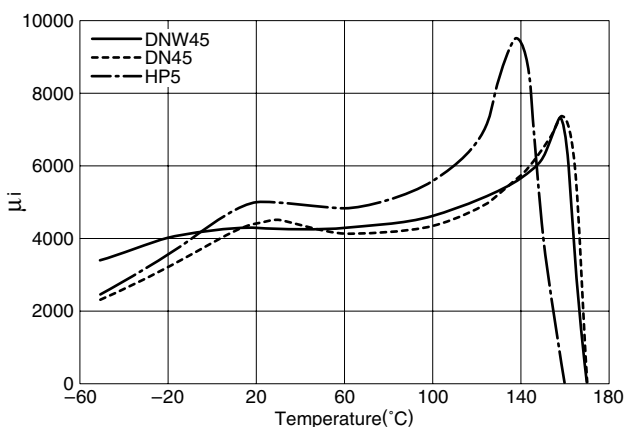

μ_Δ vs. TEMPERATURE CHARACTERISTICS

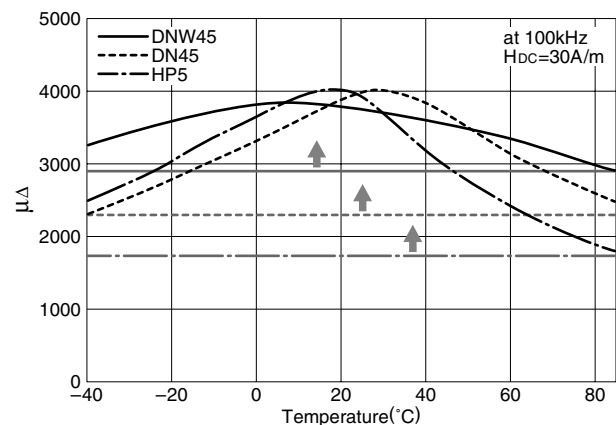

FERRITE MATERIALS FOR LAN PULSE TRANSFORMERS DN45

Pulse transformers for high-speed LANs must provide low insertion loss at a wide range of frequencies, high inductance at low frequency ranges, and the suppression of coil resistance and leakage inductance at high frequency ranges. In particular, 100 Base-T pulse transformers must be able to maintain an inductance of 350 μ H minimum at DC bias 8mA and a temperature range from 0 to 70°C.

This product meets these requirements and realizes a 30% improvement in DC superposition over our previous material HP5, and is therefore the optimum solution for 100 Base-T pulse transformer cores.

FEATURES

- Provides high inductance and excellent DC superposition over a wide temperature range (0 to 70°C).
- Provides 30% improvement in DC superposition over our previous material HP5.
- Coil windings can be reduced by 20% compared to material HP5.

MATERIAL CHARACTERISTICS

COMPARISON TO PREVIOUS MATERIAL (HP5)

Material				DN45(NEW)	HP5
Initial permeability	μ_i		25°C	4500 \pm 25%	5000 \pm 25%
Relative loss factor [10kHz]	$\tan\delta/\omega_i$	$\times 10^{-6}$	25°C	<3.5	<3.5
Saturation magnetic flux density [1000A/m]	Bs	mT	25°C	460	400
Curie temperature	Tc	°C	min.	150	140
Density	db	kg/m ³		4.85 $\times 10^3$	4.8 $\times 10^3$
Electrical resistivity	ρ_v	$\Omega \cdot m$		0.3	0.15

- Various toroidal cores of small sizes are available. Please contact us for details.

μ_i vs. TEMPERATURE CHARACTERISTICS

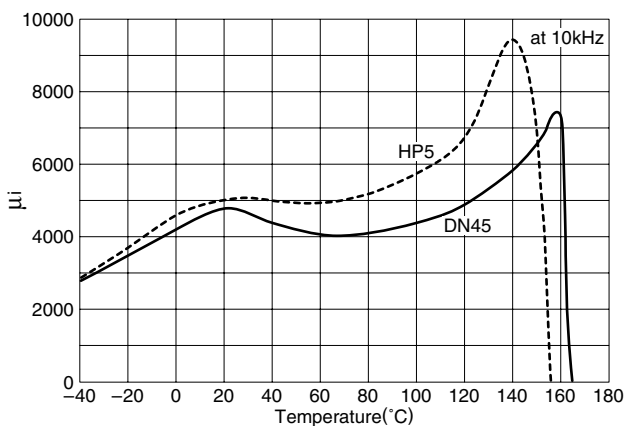

$\mu\Delta$ vs. TEMPERATURE CHARACTERISTICS

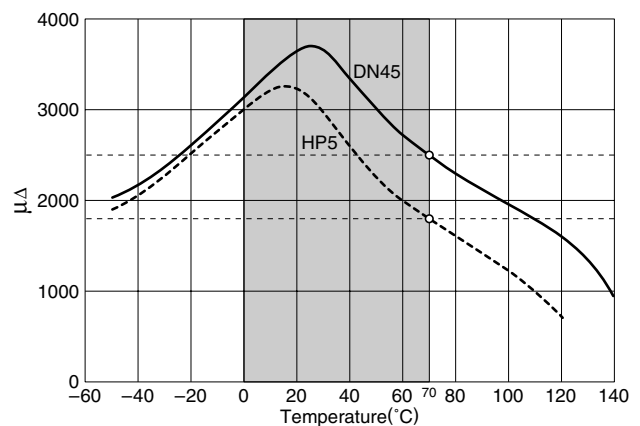

Toroidal core(OD3.05 \times ID2.54 \times T1.27mm)
DC bias current=8mA(H_{DC} =32.1A/m), 100kHz, 100mV, N=24Ts

LOW THD MATERIALS FOR xDSL MODEM TRANSFORMERS DN40 AND DN70

The use of xDSL technique becomes wide spread as a high broad-band access to the internet. In order to utilize such network access as sufficient as possible, low THD (Total Harmonic Distortion) of transformer for xDSL modem is quite important to transfer the significant signals.

Materials DN40 and DN70, TDK achieved such requirements recently, are developed to meet low THD over a wide temperature range(0 to 85°C) and wide frequency range(≥ 5 kHz).

Therefore, They are suitable for the high performance transformer design for xDSL modem applications.

Standardization of AL-value will help you to select the optimum core at the transformer design.

FEATURES

- Meet low THD over a wide temperature range(0 to 85°C) and wide frequency range (≥ 5 kHz).

APPLICATIONS

- Transformer for xDSL modem

APPLIED CORE TYPE AND AL-value

Core	Type	AL-value
EP	EP7	40, 63, 100, 160, 250
	EP10	40, 63, 100, 160, 250
	EP13	63, 100, 160, 250, 400, 500

MATERIAL CHARACTERISTICS

Material				DN70(NEW)	DN40
Initial permeability	μ_i		25°C	7500 \pm 25%	4000 \pm 25%
Relative loss factor [10kHz]	$\tan\delta/\mu_i$	$\times 10^{-6}$	25°C	<2.0	<2.5
Temperature factor of initial permeability	$\alpha_{\mu i r}$		-30 to +20°C 20 to 70°C	-0.5 to +1.5 -0.5 to +1.5	-0.5 to 2.0 -0.5 to 2.0
Saturation magnetic flux density [1000A/m]	B_s	mT	25°C	390	405
Hysteresis material constant [25°C, 1.5 to 3.0mT, 10kHz]	η_B	$\frac{10^{-6}}{\text{mT}}$		<0.2	<0.8
Curie temperature	T_c	°C	min.	105	130
Density	ρ_b	kg/m ³		5.0 $\times 10^3$	4.8 $\times 10^3$
Electrical resistivity	ρ_v	$\Omega \cdot \text{m}$		0.3	1.0

• Unless otherwise specify the tolerance, the values are shown as a typical.

THD TEMPERATURE DEPENDENCE CHARACTERISTICS (Typical) μ_i vs. TEMPERATURE CHARACTERISTICS (Typical)

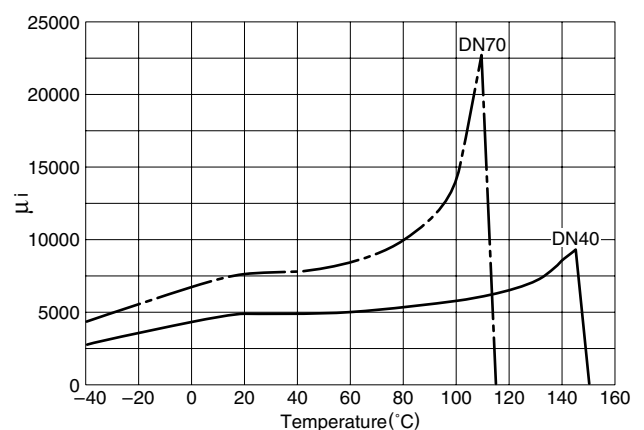
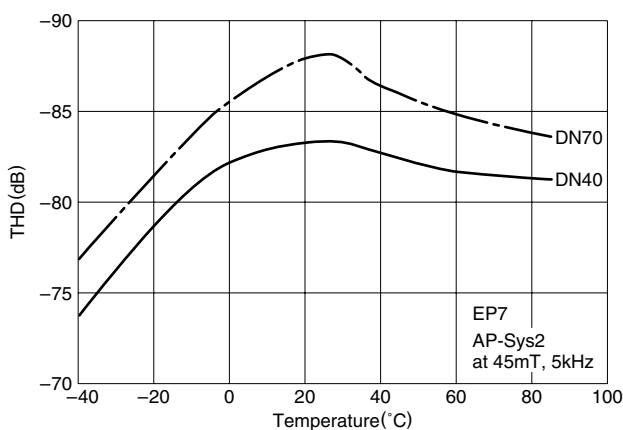

• All specifications are subject to change without notice.

E SERIES

Cores

- EI12.5 to EI60
- EE8 to EE62.3/62/6
- EF12.6 to EF32
- EER25.5 to EER49
- ETD19 to ETD49
- EC70 to EC120

Bobbins

- BE8 to BE62.3
- BEER25.5 to BEER49
- BETD19 to BETD24
- BEC70 to BEC90

Accessories

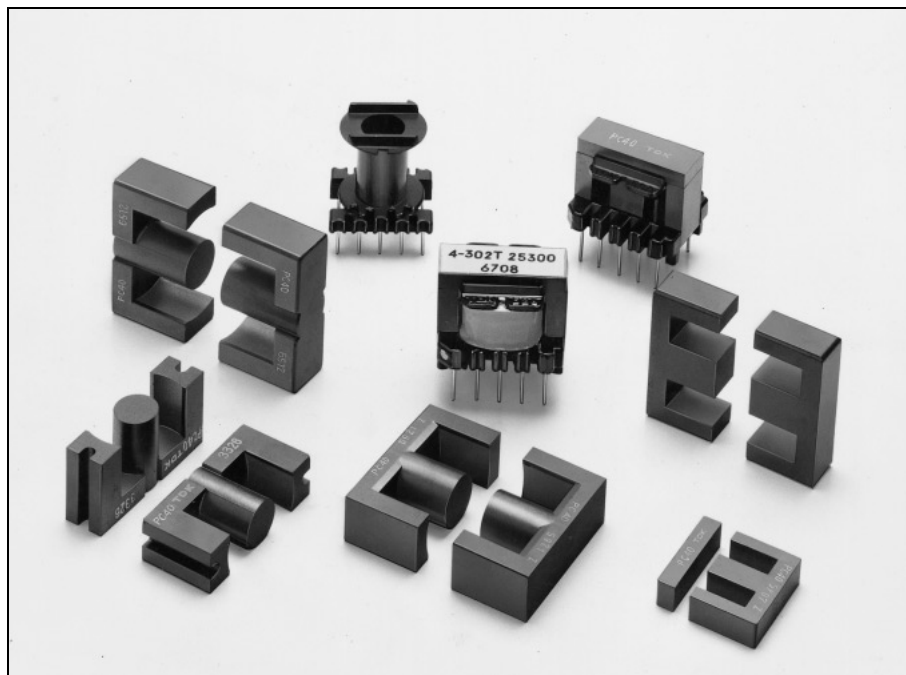

Ordering Code System

Cores

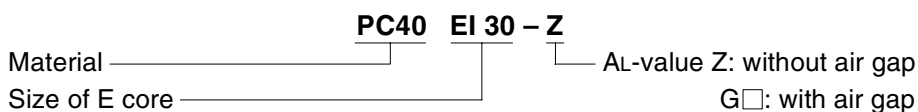

Bobbins

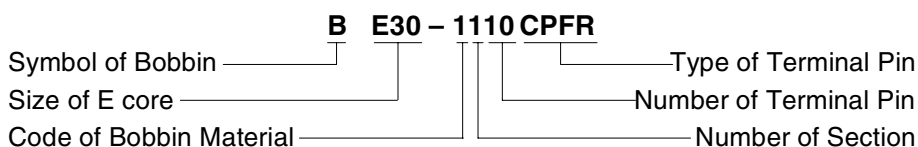

Accessories

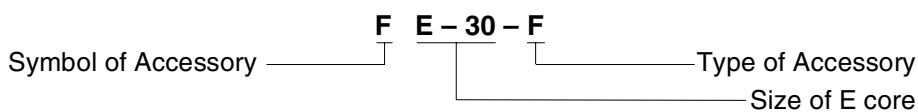

EI CORES

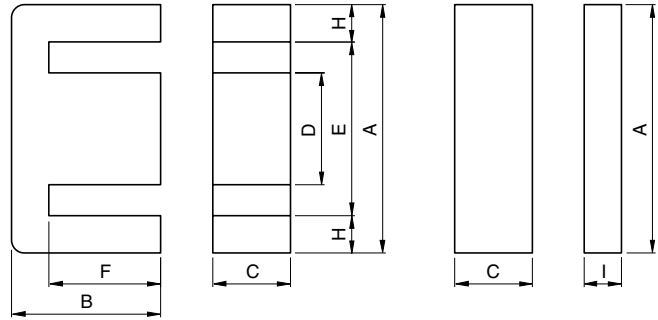
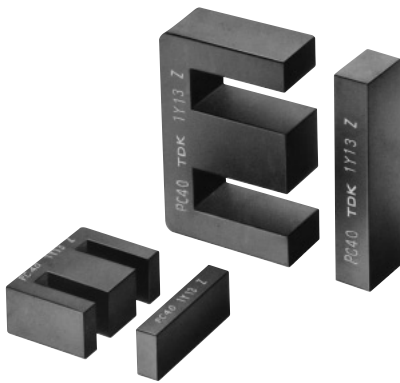

Part No.	JIS	Dimensions in		A	B	C	D	E	F	H	I
		mm	inches								
PC40EI12.5-Z	JIS	12.4±0.3	7.4±0.1	4.85±0.15	2.4±0.1	8.8	5.1±0.1	1.6	1.5±0.1		
	FEI 12.5	.488±.012	.291±.004	.191±.006	.094±.004	.346	.201±.004	.063	.059±.004		
PC40EI16-Z	JIS	16.0±0.3	12.2±0.2	4.8±0.2	4.0±0.2	11.6	10.2±0.2	2.05	2.0±0.2		
	FEI 16	.630±.012	.480±.008	.189±.008	.157±.008	.457	.402±.008	.081	.079±.008		
PC40EI19-Z		20.0±0.3	13.55±0.25	5.0±0.2	4.55±0.15	14.3	11.15±0.15	2.75	2.3±0.1		
		.787±.012	.533±.010	.197±.008	.179±.006	.563	.439±.006	.108	.091±.004		
PC40EI22-Z		22.0±0.3	14.55±0.25	5.75±0.25	5.75±0.25	13.0	10.55±0.25	4.5	4.5±0.2		
		.866±.012	.573±.010	.226±.010	.226±.010	.512	.415±.010	.177	.177±.008		
PC40EI22/19/6-Z	JIS	22.0±0.4	14.7±0.2	5.75±0.25	5.75±0.25	15.75	10.7±0.2	3.0	4.0±0.2		
	FEI 22	.866±.016	.579±.008	.226±.010	.226±.010	.620	.421±.008	.118	.157±.008		
PC40EI25-Z		25.3±0.5	15.55±0.25	6.75±0.25	6.5±0.3	19.0	12.35±0.25	3.0	2.7±0.2		
		.996±.020	.612±.010	.266±.010	.256±.012	.748	.486±.010	.118	.106±.008		
PC40EI28-Z	JIS	28.0 ^{+0.7} _{-0.5}	16.75±0.25	10.6±0.2 (E core) .417±.008	7.2±0.3	18.4	12.25±0.25	4.5	3.5±0.3		
	FEI 28	1.102 ^{+0.028} _{-.020}	.659±.010	10.7±0.3 (I core) .421±.012	.283±.012	.724	.482±.010	.177	.138±.012		

Part No.	Effective parameter				Electrical characteristics			Wt (g)	Bobbin item
	C ₁ (mm ⁻¹)	A _e (mm ²)	l _e (mm)	V _e (mm ³)	AL-value (nH/N ²)*		Core loss (W) max. 100kHz, 200mT, 100°C		
					Without air gap	With air gap			
PC40EI12.5-Z	1.48	14.4	21.3	308	1200±25%	63±7% 100±10%	0.12	1.9	BE12.5-1110CPFR
PC40EI16-Z	1.75	19.8	34.6	685	1100±25%	80±7% 160±10%	0.31	3.3	BE16-116CPFR BE16-118CPHFR BE16-1110CPNFR
PC40EI19-Z	1.65	24.0	39.6	950	1400±25%	80±7% 160±10%	0.42	5.1	BE19-116CPFR BE19-118CPHFR BE-19-5116
PC40EI22-Z	0.936	42.0	39.3	1650	2400±25%	125±7% 250±10%	0.6	9.8	BE22-1110CPFR BE22-118CPFR BE-22-5116
PC40EI22/19/6-Z	1.13	37.0	41.8	1550	2000±25%	125±7% 250±10%	0.64	8.5	BE22/19/6-118CPFR
PC40EI25-Z	1.15	41.0	47.0	1930	2140±25%	125±7% 250±10%	0.79	9.8	BE25-118CPFR BE-25-5116
PC40EI28-Z	0.57	86.0	48.2	4150	4300±25%	200±5% 400±7%	1.65	22	BE28-1110CPLFR

* AL-value: 1kHz, 0.5mA, 100Ts

EI CORES

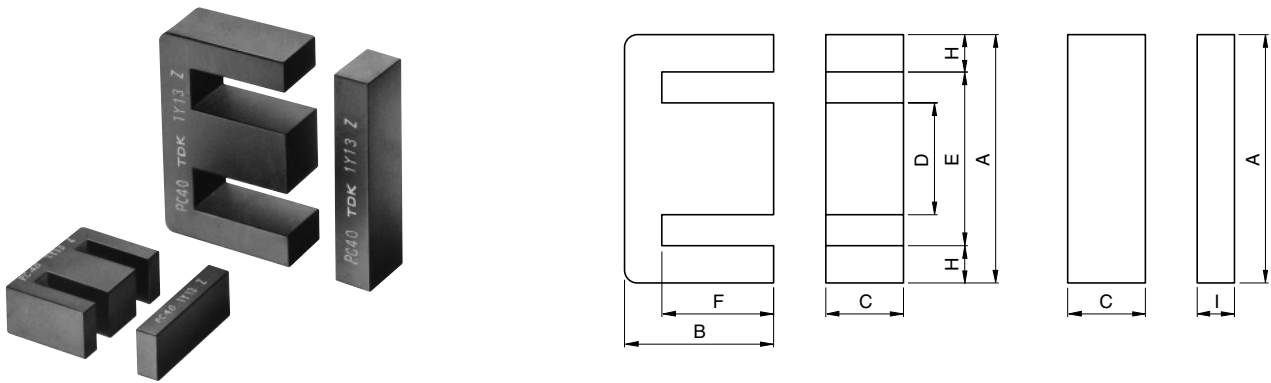

Part No.	JIS	Dimensions in		C	D	E	F	H	I
		mm	inches						
PC40EI30-Z	JIS	30.0 ^{+0.7} _{-0.4}	21.25±0.25	10.7±0.3	10.7±0.3	19.7	16.25±0.25	5.0	5.5±0.2
	FEI 30	1.181 ^{+0.028} _{-0.016}	.837±.010	.421±.012	.421±.012	.776	.640±.010	.197	.217±.008
PC40EI33/29/13-Z	JIS	33.0 ^{+0.8} _{-0.5}	23.75±0.25	12.7±0.3	9.7±0.3	23.4	19.25±0.25	4.45	5.0±0.3
	FEI 30	1.299 ^{+0.031} _{-0.020}	.935±.010	.500±.012	.382±.012	.921	.758±.010	.175	.197±.012
PC40EI35-Z	JIS	35.0±0.5	24.35±0.15	10.0±0.3	10.0±0.3	24.5	18.25±0.15	5.0	4.6±0.3
	FEI 35	1.378±.020	.959±.006	.394±.012	.394±.012	.965	.719±.006	.197	.181±.012
PC40EI40-Z	JIS	40.0±0.5	27.25±0.25	11.65±0.35	11.65±0.35	27.2	20.25±0.25	6.2	7.5±0.3
	FEI 40	1.575±.020	1.073±.010	.459±.014	.459±.014	1.071	.797±.010	.244	.295±.012
PC40EI50-Z	JIS	50.0 ^{+1.2} _{-0.7}	33.35±0.35	14.6±0.4	14.6±0.4	33.5	24.75±0.25	7.7	9.0±0.3
	FEI 50	1.969 ^{+0.047} _{-0.028}	1.313±.014	.575±.016	.575±.016	1.319	.974±.010	.303	.354±.012
PC40EI60-Z	JIS	60.0 ^{+1.4} _{-0.8}	35.85±0.35	15.6±0.4	15.6±0.4	43.6	27.85±0.35	7.7	8.5±0.3
	FEI 60	2.362 ^{+0.055} _{-0.031}	1.411±.014	.614±.016	.614±.016	1.717	1.096±.014	.303	.335±.012

Part No.	Effective parameter				Electrical characteristics			Wt (g)	Bobbin item
	C ₁ (mm ⁻¹)	A _e (mm ²)	l _e (mm)	V _e (mm ³)	AL-value (nH/N ²)*		Core loss (W) max. 100kHz, 200mT, 100°C		
					Without air gap	With air gap			
PC40EI30-Z	0.522	111	58.0	6440	4690±25%	200±5% 400±7%	3.1	34	BE30-1110CPFR BE30-1112CPFR BE-30-5112
PC40EI33/29/13-Z	0.567	119	67.5	8030	4400±25%	200±5% 400±7%	3.5	41	BE33-1112CPLFR
PC40EI35-Z	0.664	101	67.1	6780	3800±25%	200±5% 400±7%	2.85	36	BE35-1112CPLFR
PC40EI40-Z	0.520	148	77.0	11400	4860±25%	200±5% 400±7%	4.8	60	BE40-1112CPFR BE40-1112CPNFR BE-40-5112
PC40EI50-Z	0.409	230	94.0	21620	6110±25%	250±5% 500±7%	9.2	115	BE50-1112CPFR BE-50-5112
PC40EI60-Z	0.441	247	109	26900	5670±25%	250±5% 500±7%	12.5	139	BE60-1112CPFR BE-60-5112

* AL-value: 1kHz, 0.5mA, 100Ts

EE AND EF CORES

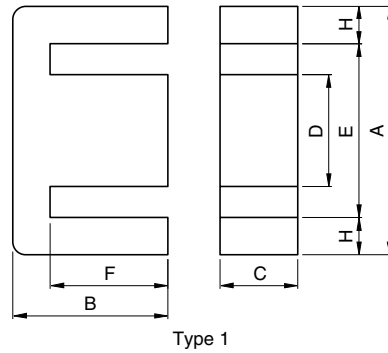
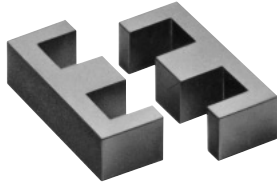
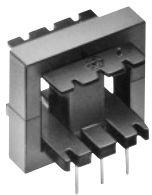

Type 1

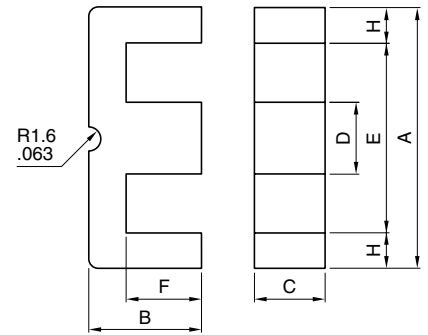

Type 2

Part No.	U.S. lam. cores, DIN standard JIS	Type	Dimensions in						
			mm		inches				
			A	B	C	D	E	F	H
PC40EE8-Z	JIS	1	8.3±0.2	4.0±0.1	3.6±0.2	1.85±0.15	6.0	3.0±0.1	1.0
	FEE 8.3		.327±.008	.157±.004	.142±.008	.073±.006	.236	.118±.004	.039
PC40EE10/11-Z	JIS	1	10.2±0.2	5.5±0.1	4.75±0.15	2.45±0.15	7.7	4.20±0.15	1.1
	FEE 10.2		.402±.008	.217±.004	.187±.006	.096±.006	.303	.165±.006	.043
PC40EF12.6-Z	DIN 41985	1	12.7±0.4	6.4±0.1	3.6±0.2	3.65±0.15	8.8	4.65±0.15	1.83
			.500±.016	.252±.004	.142±.008	.144±.006	.346	.183±.006	.072
PC40EE13-Z		1	13.0±0.2	6.00±0.15	6.15±0.15	2.75±0.15	10.0	4.6±0.1	1.4
			.512±.008	.236±.006	.242±.006	.108±.006	.394	.181±.004	.055
PC40EE16-Z	JIS FEE 16A	1	16.0±0.3	7.15±0.15	4.8±0.2	4.0±0.2	11.7	5.1±0.2	2.0
			.630±.012	.281±.006	.189±.008	.157±.008	.461	.201±.008	.079
PC40SEE16-Z		1	16.0±0.3	7.15±0.15	6.8±0.2	3.18±0.18	12.5	5.5±0.1	1.6
			.630±.012	.281±.006	.268±.008	.125±.007	.492	.217±.004	.063
PC40EF16-Z	DIN 41985	1	16.1±0.6	8.05±0.15	4.5±0.2	4.55±0.15	11.3	5.9±0.2	2.2
			.634±.024	.317±.006	.177±.008	.179±.006	.445	.232±.008	.087
PC40EE19-Z	JIS FEE 19A	1	19.1±0.3	7.95±0.15	5.0±0.2	4.55±0.15	14.2	5.6±0.1	2.3
			.752±.012	.313±.006	.197±.008	.179±.006	.559	.220±.004	.091
PC40EE19/16-Z	U.S. EE-187	1	19.29±0.32	8.1±0.18	4.75±0.13	4.75±0.08	14.05	5.715±0.125	2.46
			.759±.013	.319±.007	.187±.005	.187±.003	.553	.225±.005	.097

Part No.	Effective parameter				Electrical characteristics			Wt (g)	Bobbin item
	C ₁ (mm ⁻¹)	A _e (mm ²)	ℓ _e (mm)	V _e (mm ³)	AL-value (nH/N ²)*		Core loss (W) max. 100kHz, 200mT, 100°C		
					Without air gap	With air gap			
PC40EE8-Z	2.75	7.0	19.2	134	610±25%	40±7% 63±10%	0.06	0.7	BE8-116CPHFR
PC40EE10/11-Z	2.16	12.1	26.1	315	850±25%	40±7% 63±10%	0.14	1.5	BE10-118CPSFR
PC40EF12.6-Z	2.28	13.0	29.6	385	810±25%	63±7% 100±10%	0.17	2.0	—
PC40EE13-Z	1.77	17.1	30.2	517	1130±25%	63±7% 100±10%	0.235	2.7	BE13-1110CPSFR
PC40EE16-Z	1.82	19.2	34.5	656	1140±25%	80±7% 160±10%	0.31	3.3	BE16-116CPFR BE16-118CPHFR BE16-1110CPNFR
PC40SEE16-Z	1.69	21.7	36.6	795	1240±25%	80±7% 160±10%	0.37	4.1	BES16-1110CPSFR
PC40EF16-Z	1.87	20.1	37.6	754	1100±25%	63±7% 100±10%	0.32	3.9	—
PC40EE19-Z	1.71	23.0	39.4	906	1250±25%	80±7% 160±10%	0.42	4.8	BE19-116CPFR BE19-118CPHFR BE-19-5116
PC40EE19/16-Z	1.75	22.4	39.1	876	1350±25%	80±7% 160±10%	0.41	4.8	

* AL-value: 1kHz, 0.5mA, 100Ts

EE AND EF CORES

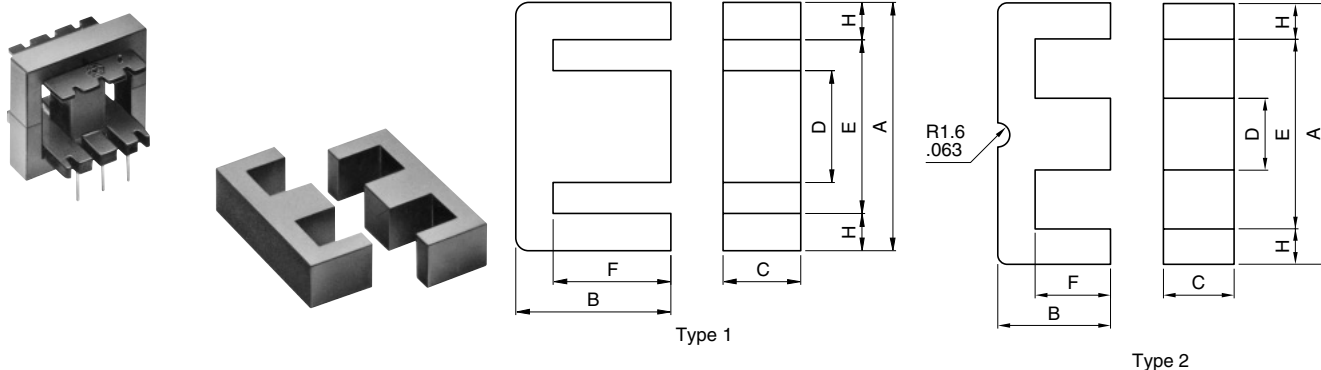

Part No.	U.S. lam. cores, DIN standard JIS	Type	Dimensions in		C	D	E	F	H
			mm	inches					
PC40EE20/20/5-Z	DIN 41295	2	20.15±0.55	10.0±0.2	5.1±0.2	5.0±0.2	12.8	6.5±0.2	3.53
			.793±.022	.394±.008	.201±.008	.197±.008	.504	.256±.008	.139
PC40EF20-Z	DIN 41985	1	20.0±0.4	9.9±0.2	5.65±0.25	5.7±0.2	14.1	7.2±0.2	2.8
			.787±.016	.390±.008	.222±.010	.224±.008	.555	.283±.008	.110
PC40EE22-Z		1	22.0±0.3	9.35±0.15	5.75±0.25	5.75±0.25	13.0	5.35±0.15	4.3
			.866±.012	.368±.006	.226±.010	.226±.010	.512	.211±.006	.169
PC40EE25/19-Z	U.S. EE-24/25	1	25.4±0.5	9.46±0.19	6.29±0.19	6.35±0.25	18.55	6.41±0.19	3.11
			1.000±.020	.372±.007	.248±.007	.250±.010	.730	.252±.007	.122
PC40EF25-Z	DIN 41985	1	25.05±0.75	12.55±0.25	7.2±0.3	7.25±0.25	17.5	8.95±0.25	3.55
			.986±.030	.494±.010	.283±.012	.285±.010	.689	.352±.010	.140
PC40EE25.4-Z	JIS FEE 25.4A	1	25.4±0.76	9.66±0.15	6.35±0.25	6.35±0.25	18.5	6.48±0.15	3.18
			1.000±.030	.380±.006	.250±.010	.250±.010	.728	.255±.006	.125
PC40EE30-Z	JIS FEE 30A	1	30.0±0.5	13.15±0.15	10.7±0.3	10.7±0.3	19.7	8.15±0.15	5.0
			1.181±.020	.518±.006	.421±.012	.421±.012	.776	.321±.006	.197
PC40EE30/30/7-Z	DIN 41295	2	30.1±0.7	15.0±0.2	7.05±0.25	6.95±0.25	19.5	9.95±0.25	5.1
			1.185±.028	.591±.008	.278±.010	.274±.010	.768	.392±.010	.201

Part No.	Effective parameter				Electrical characteristics			Wt (g)	Bobbin item
	C ₁ (mm ⁻¹)	A _e (mm ²)	l _e (mm)	V _e (mm ³)	AL-value (nH/N ²)*		Core loss (W) max. 100kHz, 200mT, 100°C		
					Without air gap	With air gap			
PC40EE20/20/5-Z	1.38	31.0	43.0	1340	1400±25%	100±7% 160±10%	0.51	7.5	—
PC40EF20-Z	1.34	33.5	44.9	1500	1570±25%	100±7% 160±10%	0.69	7.4	—
PC40EE22-Z	0.970	41.0	39.6	1620	2180±25%	125±7% 250±10%	0.61	8.8	BE22-1110CPFR BE22-118CPFR BE-22-5116
PC40EE25/19-Z	1.22	40.0	48.7	1950	2000±25%	100±7% 200±10%	0.86	9.1	—
PC40EF25-Z	1.11	51.8	57.8	2990	2000±25%	100±7% 160±10%	1.40	15	—
PC40EE25.4-Z	1.21	40.3	48.7	1963	2000±25%	125±7% 250±10%	0.90	10	—
PC40EE30-Z	0.529	109.0	57.7	6290	4690±25%	200±5% 400±7%	2.90	32	BE30-1110CPFR BE30-1112CPFR BE-30-5112
PC40EE30/30/7-Z	1.12	59.7	66.9	4000	2100±25%	160±5% 250±7%	1.51	22	—

* AL-value: 1kHz, 0.5mA, 100Ts

EE AND EF CORES

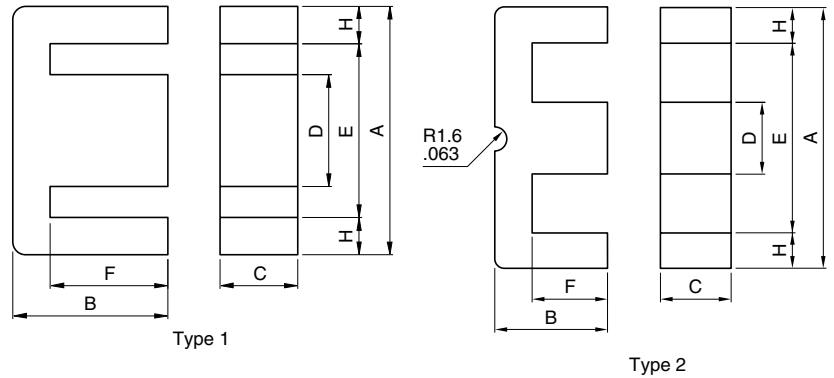
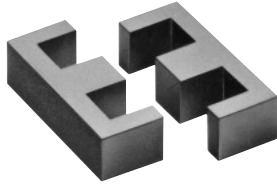
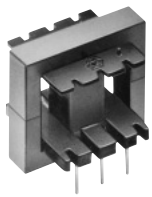

Part No.	U.S. lam. cores, DIN standard JIS	Type	Dimensions in							
			mm		inches					
			A	B	C	D	E min.	F	H	
PC40EF32-Z	DIN 41985	1	32.1±0.8 1.264±.031	16.1±0.3 .634±.012	9.15±0.35 .360±.014	9.2±0.3 .362±.012	22.7 .894	11.6±0.3 .457±.012	4.4 .173	
PC40EE35/28B-Z	U.S. EE-375	1	34.6±0.5 1.362±.020	14.27±0.37 .562±.014	9.31±0.30 .367±.012	9.4±0.3 .370±.012	25.0 .984	9.78±0.25 .385±.010	4.5 .177	
PC40EE35-Z	JIS FEE35B	1	34.54±1.0 1.360±.039	14.35±0.35 .564±.014	9.53±0.38 .375±.015	9.39±0.27 .370±.011	24.89 .980	9.71±0.28 .382±.011	4.75 .187	
PC40EE40-Z	JIS FEE40A	1	40.0±0.5 1.575±.020	17.0±0.3 .669±.012	10.7±0.3 .421±.012	10.7±0.3 .421±.012	27.4 1.079	10.25±0.25 .404±.010	6.0 .236	
PC40EE41/33C-Z	U.S. EE-21	1	41.07±0.8 1.617±.031	16.78±0.4 .661±.016	12.57±0.38 .495±.015	12.64±0.45 .498±.018	28.55 1.124	10.38±0.3 .409±.012	6.0 .236	
PC40EE42/42/15-Z	DIN 41295	JIS FEE42A	1	42.15±0.85 1.659±.033	21.0±0.2 .827±.008	14.95±0.25 .589±.010	11.95±0.25 .470±.010	29.5 1.161	15.15±0.35 .596±.014	6.025 .237
PC40EE42/42/20-Z	DIN 41295	JIS FEE42B	1	42.15±0.85 1.659±.033	21.0±0.2 .827±.008	19.7±0.3 .776±.012	11.95±0.25 .470±.010	29.5 1.161	15.15±0.35 .596±.014	6.025 .237

Part No.	Effective parameter				Electrical characteristics			Wt (g)	Bobbin item
	C ₁ (mm ⁻¹)	A _e (mm ²)	l _e (mm)	V _e (mm ³)	AL-value (nH/N ²)*		Core loss (W) max. 100kHz, 200mT, 100°C		
					Without air gap	With air gap			
PC40EF32-Z	0.893	83.2	74.3	6180	2590±25%	160±5% 250±7%	2.90	32	—
PC40EE35/28B-Z	0.819	84.9	69.6	5907	2950±25%	200±5% 400±7%	2.33	28	—
PC40EE35-Z	0.774	89.3	69.2	6179	3170±25%	200±5% 400±7%	3.00	33	—
PC40EE40-Z	0.606	128	77.3	9890	4150±25%	200±5% 400±7%	4.20	50	BE40-1112CPFR BE40-1112CPNFR BE-40-5112
PC40EE41/33C-Z	0.495	157	77.6	12165	5060±25%	200±5% 400±7%	5.80	64	—
PC40EE42/42/15-Z	0.547	178	97.4	17400	4700±25%	250±5% 400±7%	8.00	80	—
PC40EE42/42/20-Z	0.415	235	97.4	22900	6100±25%	250±5% 400±7%	10.4	116	—

* AL-value: 1kHz, 0.5mA, 100Ts

EE AND EF CORES

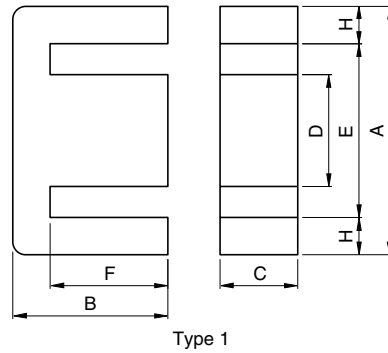
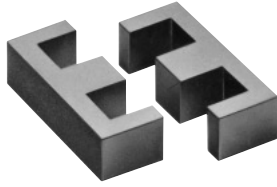
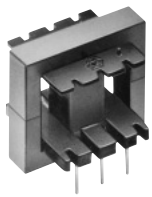

Type 1

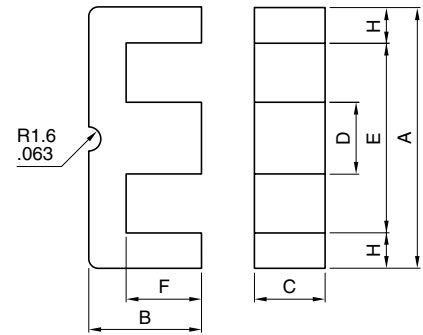

Type 2

Part No.	U.S. lam. cores, DIN standard JIS		Type	Dimensions in						
				mm		inches				
			A	B	C	D	E	F	H	
PC40EE47/39-Z	U.S. EE-625		1	47.12±0.48 1.855±0.019	19.63±0.2 .773±.008	15.62±0.25 .615±.010	15.62±0.25 .615±.010	31.72 1.249	12.2±0.13 .480±.005	7.49 .295
PC40EE50-Z	JIS FEE50A		1	50.0 ^{+1.0} _{-0.7} 1.969 ^{+0.039} _{-.028}	21.3±0.3 .839±.012	14.6±0.4 .575±.016	14.6±0.4 .575±.016	34.2 1.346	12.75±0.25 .502±.010	7.5 .295
PC40EE55/55/21-Z	DIN 41295	JIS FEE55	1	55.15±1.05 2.17±.041	27.5±0.3 1.083±.012	20.7±0.3 .815±.012	16.95±0.25 .667±.010	37.5 1.476	18.8±0.3 .740±.012	8.53 .336
PC40EE57/47-Z	U.S. EE-75		1	56.57±1.00 2.227±.039	23.60±0.23 .929±.009	18.8±0.25 .740±.010	18.80±0.25 .740±.010	38.1 1.500	14.63±0.15 .576±.006	9.02 .355
PC40EE60-Z	JIS FEE60A		1	60.0 ^{+1.1} _{-0.8} 2.362 ^{+0.043} _{-.031}	22.3±0.3 .878±.012	15.6±0.4 .614±.016	15.6±0.4 .614±.016	43.8 1.724	14.05±0.25 .553±.010	7.7 .303
PC40EE50.3/51/6-Z			1	50.3±0.8 1.980±.031	25.6±0.25 1.008±.010	6.1 ^{+0.4} _{-0.2} .240 ^{+0.016} _{-.008}	19.9±0.35 .783±.014	29.5 1.161	15.9±0.25 .626±.010	10 .394
PC40EE62.3/62/6-Z			1	62.3±1.2 2.453±.047	31.0±0.25 1.220±.010	6.1 ^{+0.4} _{-0.2} .240 ^{+0.016} _{-.008}	25.3±0.5 .996±.020	35.9 1.413	18.7±0.25 .736±.010	12.6 .496

Part No.	Effective parameter				Electrical characteristics			Wt (g)	Bobbin item
	C ₁ (mm ⁻¹)	A _e (mm ²)	l _e (mm)	V _e (mm ³)	AL-value (nH/N ²)*		Core loss (W) max. 100kHz, 200mT, 100°C		
					Without air gap	With air gap			
PC40EE47/39-Z	0.374	242	90.6	21930	6660±25%	250±5% 400±7%	9.70	108	—
PC40EE50-Z	0.425	226	95.8	21600	6110±25%	250±5% 400±7%	9.40	116	BE50-1112CPFR BE-50-5112
PC40EE55/55/21-Z	0.348	354	123	43700	7100±25%	250±5% 400±7%	11.0**	234	—
PC40EE57/47-Z	0.297	344	102	35100	8530±25%	250±5% 400±7%	8.5**	190	—
PC40EE60-Z	0.446	247	110	27100	5670±25%	250±5% 500±7%	12.5	135	BE60-1112CPFR BE-60-5112
PC40EE50.3/51/6-Z	0.868	121	105	12700	2900±25%	200±5% 400±7%	5.83	68	BE50.3-1112CPHFR
PC40EE62.3/62/6-Z	0.823	153	126	19300	3100±25%	200±5% 400±7%	8.85	102	BE62.3-1112CPHFR

* AL-value: 1kHz, 0.5mA, 100Ts

** Core loss: 100kHz, 150mT, 100°C

EE AND EI BOBBINS

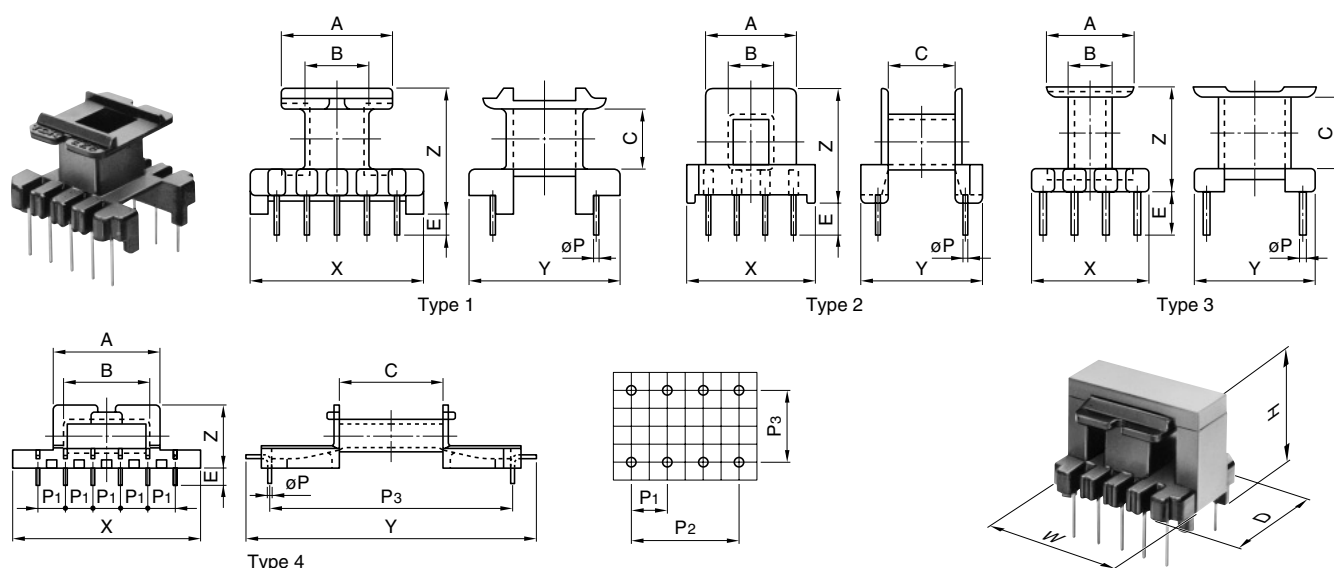

Part No.	Type	Dimensions in		A	B	C	E	X	Y	Z	t*						
		mm	inches														
BE8-116CPHFR	2	5.8	.228	3.0	.118	4.78	.188	2.7	.106	8.0	.315	8.8	.346	8.4	.331	0.35	.014
BE10-118CPSFR	3	7.2	.283	3.5	.138	6.6	.260	3.85	.152	10.2	.402	10.2	.402	9.0	.354	0.40	.016
BE12.5-1110CPFR	1	8.5	.335	3.6	.142	3.5	.138	3.25	.128	12.35	.486	12.35	.486	8.3	.327	0.325	.013
BE13-1110CPSFR	3	10.0	.394	4.0	.157	7.4	.291	3.7	.146	12.1	.476	12.5	.492	10.4	.409	0.40	.016
BE16-116CPFR	3	11.5	.453	5.15	.203	8.5	.335	3.8	.150	11.5	.453	13.0	.512	11.5	.453	0.375	.015
BE16-118CPHFR	2	11.4	.449	5.15	.203	8.6	.339	4.0	.157	15.0	.591	13.4	.528	13.4	.528	0.325	.013
BE16-1110CPNFR	1	11.35	.447	5.65	.222	8.15	.321	3.8	.150	16.0	.630	13.0	.512	13.85	.545	0.55	.022
BES-16-1110CPSFR	3	12.2	.480	4.6	.181	8.7	.343	5.0	.197	15.9	.426	14.0	.551	11.7	.461	0.40	.016
BE19-116CPFR	3	13.8	.543	5.8	.228	9.1	.358	5.0	.197	13.8	.543	16.5	.650	12.0	.472	0.35	.014
BE19-118CPHFR	2	14.0	.551	6.65	.262	9.0	.354	6.0	.236	20.0	.787	16.2	.638	18.6	.732	0.80	.031

Part No.	Dimensions in mm				Terminal pins	W D H (mm)	Parameter		Wt (g)	Accessory item
	øP (mm)	P1 (mm)	P2 (mm)	P3 (mm)			Aw (mm ²)	øw (mm)		
BE8-116CPHFR	0.6	2.5	5.0	7.0	6	8.3 8.0 8.0	5.3	19.9	0.26	—
BE10-118CPSFR	0.5	2.5	7.7	8.0	8	10.4 12.7 11.2	12.2	23.8	0.34	—
BE12.5-1110CPFR	0.6	(2.5, 2.6)	10.0	7.5	10	12.7 12.5 9.1	8.6	27.2	0.64	—
BE13-1110CPSFR	0.6	2.5	10.0	8.5	10	13.2 12.7 12.3	22.2	31.3	0.63	—
BE16-116CPFR	0.6	3.1	6.2	9.2	6	16.3 13.3 14.6	27.3	32.5	0.63	—
BE16-118CPHFR	0.6	3.0	9.0	11.0	8	16.5 14.6 13.6	26.7	33.1	0.84	—
BE16-1110CPNFR	0.6	3.25	13.0	10.5	10	16.3 13.1 15.6	23.2	33.0	1.2	—
BES-16-1110CPSFR	0.6	3.3	13.2	11.0	10	16.3 14.1 16.3	33.1	37.1	1.0	—
BE19-116CPFR	0.5	4.0	8.0	12.5	6	20.3 16.7 16.2	36.4	36.8	0.95	—
BE19-118CPHFR	0.8	5.08	15.24	12.7	8	20.3 16.2 18.8	33.1	39.1	2.4	—

UL Grade: 94V-0, Material: FR phenol, Pin material: Steel wire (Solder plated)

Maximum number of turns N that can be wound on bobbins, see section of "Maximum number of Turns on Bobbins".

* Minimum thickness of bobbin inside which core is placed, including flanges.

EE AND EI BOBBINS

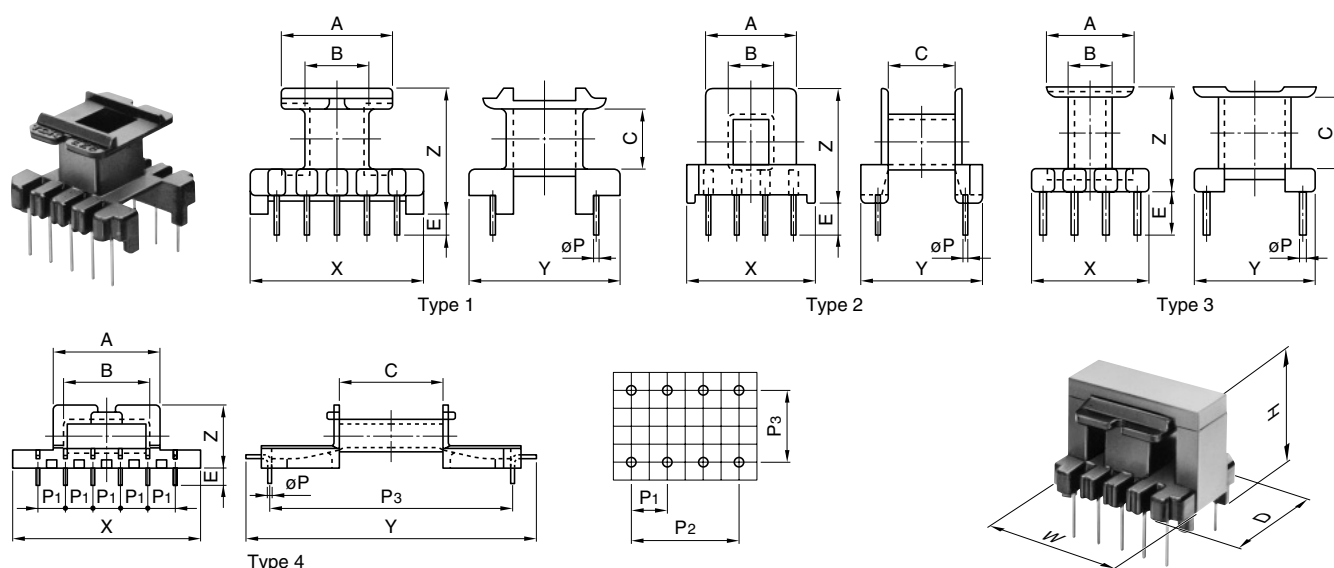

Part No.	Type	Dimensions in							
		mm		inches					
		A	B	C	E	X	Y	Z	t*
BE22-118CPFR	1	12.5 .492	7.9 .311	8.45 .332	6.0 .236	22.0 .866	17.0 .669	17.5 .689	0.80 .031
BE22/19/6-118CPFR	1	15.2 .598	7.9 .311	8.45 .332	6.0 .236	22.0 .866	17.0 .669	17.3 .681	0.80 .031
BE25-118CPFR	1	18.1 .713	9.1 .358	9.8 .386	6.0 .236	25.0 .984	18.0 .709	19.3 .760	0.75 .030
BE28-1110CPLFR	1	18.1 .713	9.9 .390	9.6 .378	7.0 .276	28.0 1.102	25.0 .984	20.6 .811	0.80 .031
BE30-1110CPFR	1	19.2 .756	13.1 .516	13.7 .539	7.0 .276	30.0 1.181	25.0 .984	25.6 1.008	0.80 .031
BE30-1112CPFR	1	19.4 .764	13.1 .516	13.7 .539	7.0 .276	30.0 1.181	25.0 .984	25.6 1.008	0.80 .031
BE33-1112CPLFR	1	23.1 .909	12.4 .488	16.6 .654	7.0 .276	33.0 1.299	28.0 1.102	28.6 1.126	0.80 .031
BE35-1112CPLFR	1	24.0 .945	12.7 .500	15.7 .618	7.0 .276	35.0 1.378	25.0 .984	28.7 1.130	0.80 .031
BE40-1112CPFR	1	26.5 1.043	14.0 .551	17.3 .681	7.0 .276	36.0 1.417	30.0 1.181	30.5 1.201	0.80 .031
BE40-1112CPNFR	1	26.5 1.043	14.0 .551	17.3 .681	7.0 .276	36.0 1.417	30.0 1.181	30.5 1.201	0.80 .031

Part No.	Dimensions in mm					Terminal pins	W D (mm) H	Parameter		Wt (g)	Accessory item
	øP (mm)	P ₁ (mm)	P ₂ (mm)	P ₃ (mm)	Aw (mm ²)			ø w (mm)			
BE22-118CPFR	0.8	5.0	15.0	12.5	8	22.3 17.1 20.1	20.0	38.6	2.3	—	
BE22/19/6-118CPFR	0.8	5.0	15.0	12.5	8	22.4 17.1 19.1	31.5	42.8	2.7	—	
BE25-118CPFR	0.8	5.0	15.0	12.5	8	25.8 18.1 20.5	42.5	49.4	3.5	—	
BE28-1110CPLFR	0.8	5.0	20.0	17.5	10	28.5 25.1 22.7	39.4	59.1	5.0	—	
BE30-1110CPFR	0.8	5.0	20.0	20.0	10	30.4 25.1 28.6	44.5	61.0	4.9	FE-30-F FE-30-G	
BE30-1112CPFR	0.8	5.0	25.0	20.0	12	30.4 25.1 28.6	43.2	58.0	6.2	—	
BE33-1112CPLFR	0.8	5.0	25.0	22.5	12	33.5 28.1 31.2	88.8	72.3	6.8	—	
BE35-1112CPLFR	0.8	5.0	25.0	20.0	12	35.5 25.1 30.9	88.7	68.5	7.7	—	
BE40-1112CPFR	1.0	5.0	25.0	25.0	12	40.5 30.2 35.8	108.0	76.0	9.7	FE-40-F FE-40-G	
BE40-1112CPNFR	1.0	5.0	25.0	22.5	12	40.5 30.2 35.7	108.1	75.6	9.8	—	

UL Grade: 94V-0, Material: FR phenol, Pin material: Steel wire (Solder plated)

Maximum number of turns N that can be wound on bobbins, see section of "Maximum number of Turns on Bobbins".

* Minimum thickness of bobbin inside which core is placed, including flanges.

EE AND EI BOBBINS

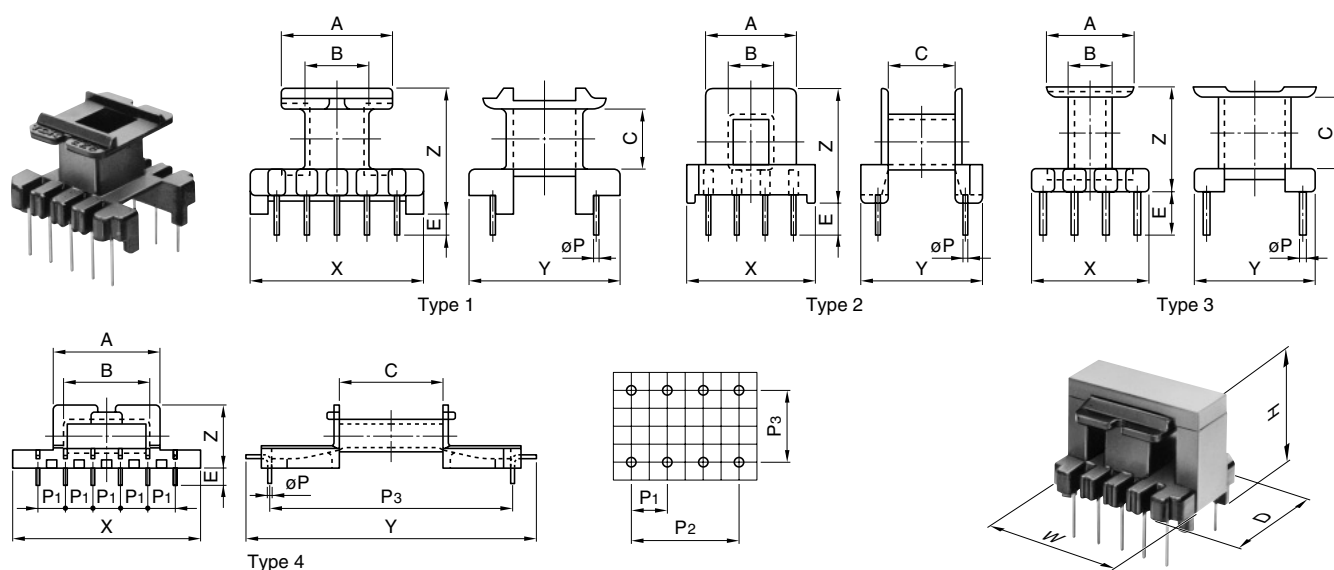

Part No.	Type	Dimensions in		A	B	C	E	X	Y	Z	t*
		mm	inches								
BE50-1112CPFR	1	33.2	17.2	21.3	9.0	50.0	36.0	36.65	0.80		
		1.307	.677	.839	.354	1.969	1.417	1.443	.031		
BE60-1112CPFR	1	43.3	18.5	23.8	10.0	56.0	45.0	38.9	0.80		
		1.705	.728	.937	.394	2.205	1.772	1.531	.031		
BE50.3-1112CPHFR	4	29.1	22.3	28.25	4.5	51.0	74.79	16.2	0.80		
		1.146	.878	1.112	.177	2.008	2.944	.638	.031		
BE62.3-1112CPHFR	4	35.1	28.3	33.85	4.5	63.0	85.6	16.2	0.80		
		1.382	1.114	1.333	.177	2.480	3.370	.638	.031		

Part No.	Dimensions in mm					Terminal pins	W D (mm) H	Parameter		Wt (g)	Accessory item
	ϕP (mm)	P1 (mm)	P2 (mm)	P3 (mm)	Aw (mm ²)			ϕw (mm)			
BE50-1112CPFR	1.0	7.5	37.5	27.5	12	50.7 36.2 43.6	170.0	94.0	17	FE-50-F FE-50-G	
BE60-1112CPFR	1.0	7.5	37.5	35.0	12	50.8 45.2 45.1	294.0	113.0	29	FE-60-F FE-60-G	
BE50.3-1112CPHFR	0.9	7.5	37.5	60	12	52 77 16.2	96.05	76	16	—	
BE62.3-1112CPHFR	0.9	7.5	37.5	72.5	12	64 88 16.2	115.09	88	22	—	

UL Grade: 94V-0, Material: FR phenol, Pin material: Steel wire (Solder plated)

Maximum number of turns N that can be wound on bobbins, see section of "Maximum number of Turns on Bobbins".

* Minimum thickness of bobbin inside which core is placed, including flanges.

EE AND EI BOBBINS

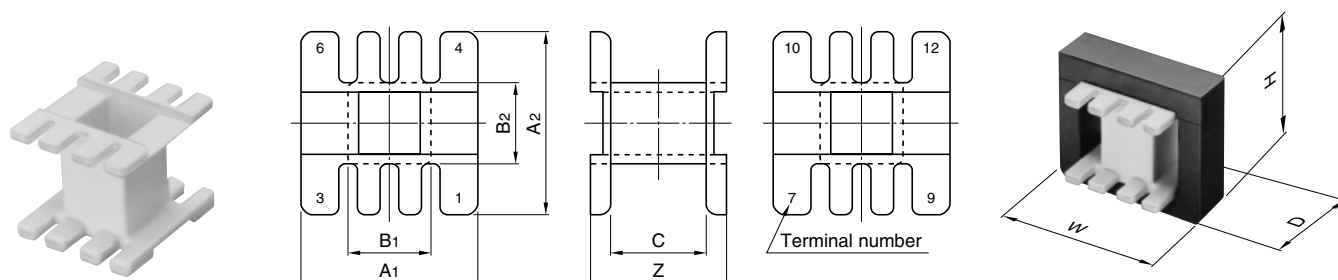

Part No.	Dimensions in							
	mm		inches					
	A1	A2	B1	B2	C	Z	t*	W D (mm) H
BE-19-5116	13.7 .539	14.8 .583	6.4 .252	7.15 .281	9.33 .367	11.93 .470	0.60 .024	20.3 14.9 16.2
BE-22-5116	12.5 .492	13.0 .512	7.7 .303	8.0 .315	8.68 .342	11.28 .444	0.575 .023	22.3 13.1 19.5
BE-25-5116	18.1 .713	19.1 .752	8.7 .343	9.2 .362	10.2 .402	14.6 .575	0.725 .029	25.8 19.2 18.7
BE-30-5112	18.85 .742	20.8 .819	13.0 .512	13.0 .512	13.95 .549	18.5 .728	0.60 .024	30.4 21.1 27.2
BE-40-5112	26.35 1.037	29.1 1.146	14.4 .567	14.4 .567	17.6 .693	23.55 .927	0.80 .031	40.5 29.4 35.3
BE-50-5112	32.75 1.289	35.55 1.400	17.4 .685	17.4 .685	22.1 .870	30.1 1.185	0.80 .031	50.7 35.8 43.0
BE-60-5112	42.75 1.683	45.75 1.801	19.5 .768	19.5 .768	24.1 .949	34.1 1.343	1.30 .051	60.8 46.0 45.0

Part No.	Parameter				Material	Accessory item
	Aw (mm ²)	∅ w (mm)	Wt (g)			
BE-19-5116	35.7	37.9	0.55		6-Nylon	
BE-22-5116	21.7	38.2	0.45		6-Nylon	
BE-25-5116	47.6	50.6	1.3		6-Nylon	
BE-30-5112	47.6	66.0	1.5		6-Nylon	FE-30-F FE-30-G
BE-40-5112	110.0	85.0	3.8		6-Nylon	FE-40-F FE-40-G
BE-50-5112	178.0	100.0	6.6		6-Nylon	FE-50-F FE-50-G
BE-60-5112	289.0	128.0	15		6-Nylon	FE-60-F FE-60-G

UL Grade: 94V-0

Maximum number of turns N that can be wound on bobbins, see section of "Maximum number of Turns on Bobbins".

* Minimum thickness of bobbin inside which core is placed, including flanges.

EER CORES

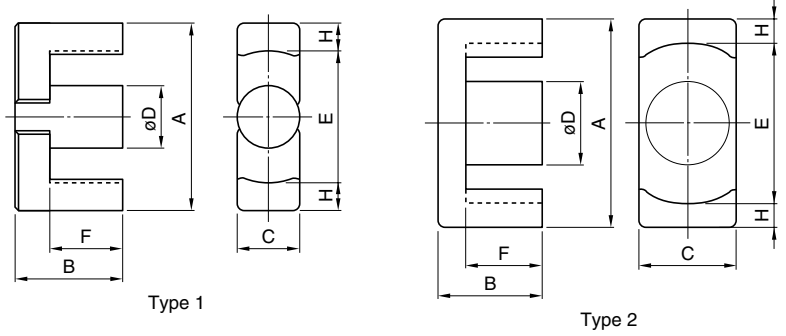

Part No.	U.S. lam. cores, DIN standard JIS	Type	Dimensions in						
			mm		inches				
			A	B	C	D	E	F	H
			min.						
PC40EER25.5-Z	JIS FEER25.5A	1	25.5±0.5	9.3±0.2	7.5±0.2	7.5±0.15	19.8	6.2±0.2	2.6
			1.004±.020	.366±.008	.295±.008	.295±.006	.779	.244±.008	.102
PC40EER28-Z	JIS FEER28.5A	2	28.55±0.55	14.0±0.2	11.4±0.25	9.9±0.25	21.2	9.65±0.25	3.4
			1.124±.022	.551±.008	.499±.010	.390±.010	.835	.380±.010	.134
PC40EER28L-Z	JIS FEER28.5B	2	28.55±0.55	16.9±0.25	11.4±0.25	9.9±0.25	21.2	12.53±0.28	3.4
			1.124±.022	.665±.010	.499±.010	.390±.010	.835	.493±.011	.134
PC40EER35-Z	JIS FEER35A	1	35.0±0.5	20.7±0.2	11.3±0.2	11.3±0.15	25.6	14.7±0.3	4.43
			1.378±.020	.815±.008	.445±.008	.445±.006	1.009	.579±.012	.174
PC40EER40-Z		1	40.0±0.5	22.4±0.2	13.3±0.25	13.3±0.25	29.0	15.4±0.3	5.28
			1.575±.020	.882±.008	.524±.010	.524±.010	1.142	.606±.012	.208
PC40EER42-Z	JIS FEER42	1	42.0±0.6	22.4±0.2	15.5±0.25	15.5±0.25	29.4	15.4±0.3	6.0
			1.654±.024	.882±.008	.610±.010	.610±.010	1.157	.606±.012	.236
PC40EER42/42/20-Z		2	42.15±0.65	21.2±0.2	19.60±0.4	17.3±0.25	31.8	15.25±0.25	4.93
			1.659±.026	.835±.008	.772±.016	.681±.010	1.252	.600±.010	.194
PC40EER49-Z		1	49.0±0.8	19.0±0.3	17.2±0.4	17.2±0.25	36.4	12.4±0.2	6.0
			1.929±.031	.748±.012	.677±.016	.677±.010	1.433	.488±.008	.236

Part No.	Effective parameter				Electrical characteristics			Wt (g)	Bobbin item
	C ₁ (mm ⁻¹)	A _e (mm ²)	ℓ _e (mm)	V _e (mm ³)	AL-value (nH/N ²)*		Core loss (W) max. 100kHz, 200mT, 100°C		
					Without air gap	With air gap			
PC40EER25.5-Z	1.08	44.8	48.2	2160	1920±25%	100±5% 200±7%	0.98	11	BEER25.5-118CPFR
PC40EER28-Z	0.780	82.1	64.0	5250	2870±25%	200±5%	2.30	28	BEER28-1110CPFR BEER28-1112CPHFR
						400±7%			
PC40EER28L-Z	0.928	81.4	75.5	6150	2520±25%	160±5%	2.70	33	BEER28L-1110CPFR BEER28L-1112CPHFR
						315±7%			
PC40EER35-Z	0.849	107	90.8	9720	2770±25%	200±5%	4.20	52	BEER35-1112CPFR BEER35-1116CPHFR
						400±7%			
PC40EER40-Z	0.658	149	98.0	14600	3620±25%	200±5%	6.30	78	BEER40-1112CPFR BEER40-1116CPHFR
						400±7%			
PC40EER42-Z	0.509	194	98.8	19200	4690±25%	250±5%	8.60	102	BEER42-1114CPFR BEER42-1116CPHFR
						500±7%			
PC40EER42/42/20-Z	0.411	240	98.6	23700	5340±25%	250±5%	10.7	116	BEER42/20-1112CPFR
						500±7%			
PC40EER49-Z	0.395	231	91.3	21100	6250±25%	250±5%	5.4**	110	BEER49-1118CPFR
						500±7%			

* AL-value: 1kHz, 0.5mA, 100Ts

** Core loss: 100kHz, 150mT, 100°C

EER BOBBINS

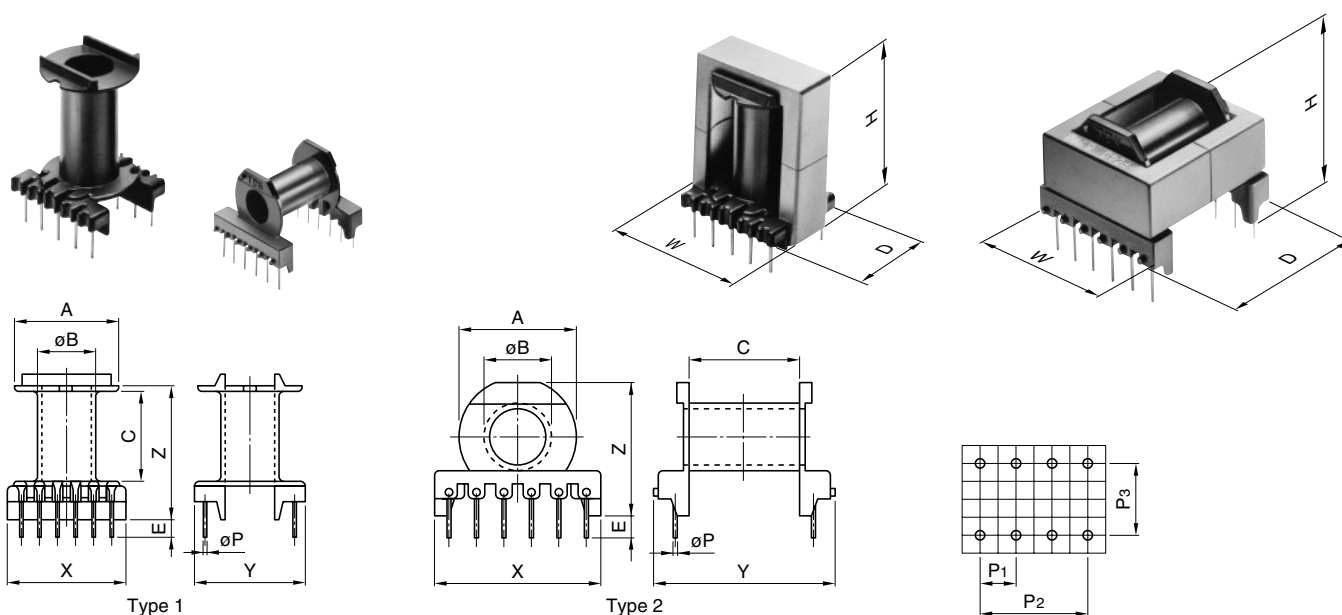

Part No.	Type	Dimensions in mm inches							
		A	øB	C	E	X	Y	Z	t*
BEER25.5-118CPFR	1	19.53 .769	9.9 .390	10.05 .396	4.5 .177	22.0 .866	19.6 .772	19.05 .750	0.8 .031
BEER28-1110CPFR	1	20.9 .823	12.3 .484	16.7 .657	4.5 .177	24.8 .976	23.0 .906	26.6 1.047	0.8 .031
BEER28L-1110CPFR	1	20.9 .823	12.3 .484	22.4 .882	4.5 .177	24.8 .976	23.0 .906	32.3 1.272	0.8 .031
BEER35-1112CPFR	1	25.4 1.000	13.7 .539	26.1 1.028	5.5 .217	30.0 1.181	28.5 1.122	39.3 1.547	0.8 .031
BEER40-1112CPFR	1	28.7 1.130	15.8 .622	27.5 1.083	5.0 .197	32.0 1.260	30.0 1.181	41.7 1.642	0.8 .031
BEER42-1114CPFR	1	29.1 1.146	17.95 .707	27.5 1.083	5.0 .197	38.0 1.496	30.0 1.181	42.7 1.681	0.8 .031
BEER42/20-1112CPFR	1	31.5 1.240	19.8 .780	27.3 1.075	5.0 .197	43.5 1.713	37.0 1.457	42.5 1.673	0.8 .031

Part No.	Dimensions in mm					Terminal pins	Parameter		Wt (g)
	øP (mm)	P ₁ (mm)	P ₂ (mm)	P ₃ (mm)	W D (mm) H		Aw (mm ²)	ℓ w (mm)	
BEER25.5-118CPFR	0.8	5.0	15	12.5	8	26 20 21	48.4	46.2	2.7
BEER28-1110CPFR	0.8	5.0	20	17.5	10	29 23 29	71.8	52.2	3.5
BEER28L-1110CPFR	0.8	5.0	20	17.5	10	29 23 35	96.3	52.2	3.9
BEER35-1112CPFR	1.0	5.0	25	22.5	12	36 29 44	152.7	61.4	7.7
BEER40-1112CPFR	1.0	5.0	25	25	12	41 30 46	178.8	69.9	8.9
BEER42-1114CPFR	1.0	5.0	30	25	14	43 30 47	153.3	73.9	9.8
BEER42/20-1112CPFR	1.0	7.5	37.5	30	12	43 37 46	159.7	80.6	12

UL Grade: 94V-0, Material: FR phenol, Pin material: Steel wire (Solder plated)

Maximum number of turns N that can be wound on bobbins, see section of "Maximum number of Turns on Bobbins".

* Minimum thickness of bobbin inside which core is placed, including flanges.

EER BOBBINS

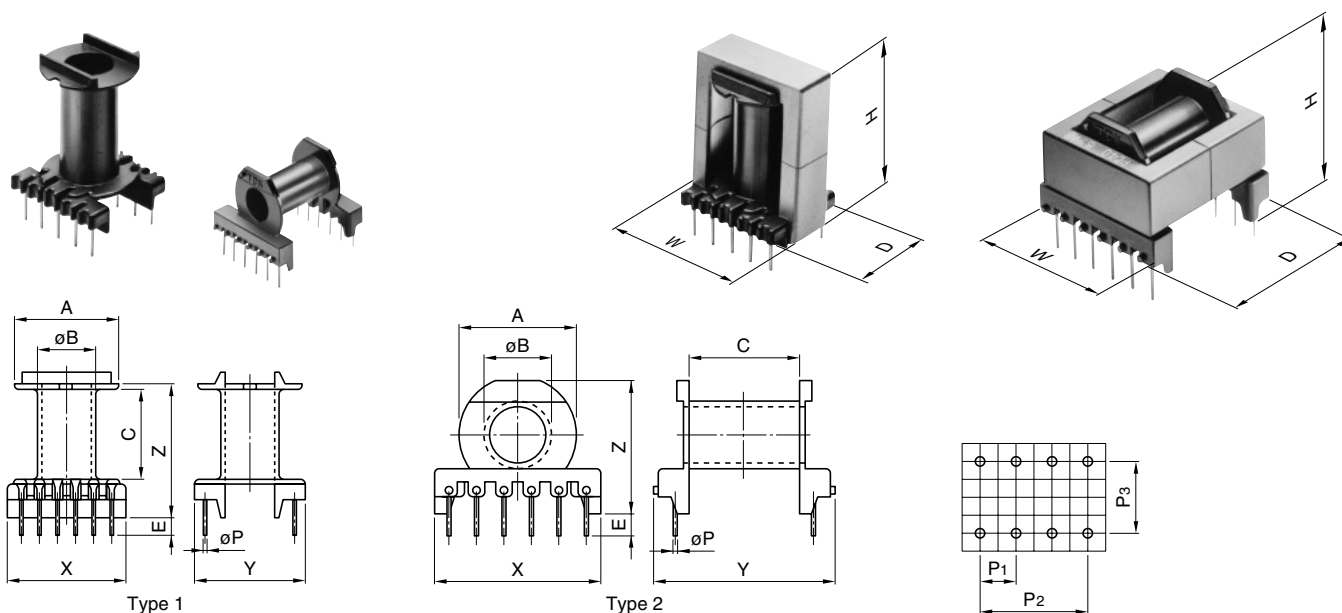

Part No.	Type	Dimensions in mm inches							
		A	øB	C	E	X	Y	Z	t*
BEER49-1118CPFR	1	35.95 1.415	20.3 .799	21.45 .844	4.5 .177	49.0 1.929	37.0 1.457	39.45 1.553	0.9 .035
BEER28-1112CPHFR	2	20.9 .823	12.0 .472	16.1 .634	5.0 .197	30.0 1.181	31.3 1.232	25.0 .984	0.8 .031
BEER28L-1112CPHFR	2	20.9 .823	12.0 .472	21.8 .858	5.0 .197	30.0 1.181	37.0 1.457	25.0 .984	0.8 .031
BEER35-1116CPHFR	2	25.2 .992	13.6 .535	26.4 1.039	4.5 .177	40.0 1.575	45.5 1.791	29.0 1.142	0.8 .031
BEER40-1116CPHFR	2	28.6 1.126	15.7 .618	27.5 1.083	4.2 .165	40.0 1.575	44.0 1.732	31.8 1.252	0.8 .031
BEER42-1116CPHFR	2	29.0 1.142	18.0 .709	27.3 1.075	5.0 .197	40.0 1.575	44.0 1.732	34.5 1.358	0.8 .031

Part No.	Dimensions in mm				Terminal pins	W D (mm) H	Parameter		Wt (g)
	øP (mm)	P1 (mm)	P2 (mm)	P3 (mm)			Aw (mm ²)	ℓ w (mm)	
BEER49-1118CPFR	0.8	5.0	40	30	18	50 37 43	167.8	88.4	15
BEER28-1112CPHFR	0.8	5.0	25	25	12	31 32 26	71.6	51.6	5.2
BEER28L-1112CPHFR	0.8	5.0	25	30	12	31 38 26	97.0	51.7	5.5
BEER35-1116CPHFR	0.75	5.0	35	35	16	41 46 31	154.4	60.8	11
BEER40-1116CPHFR	1.0	5.0	35	35	16	41 45 32	170.6	69.9	11
BEER42-1116CPHFR	1.0	5.0	35	35	16	43 46 35	148.5	73.8	12

UL Grade: 94V-0, Material: FR phenol, Pin material: Steel wire (Solder plated)
 Maximum number of turns N that can be wound on bobbins, see section of "Maximum number of Turns on Bobbins".
 * Minimum thickness of bobbin inside which core is placed, including flanges.

• All specifications are subject to change without notice.

ETD AND EC CORES

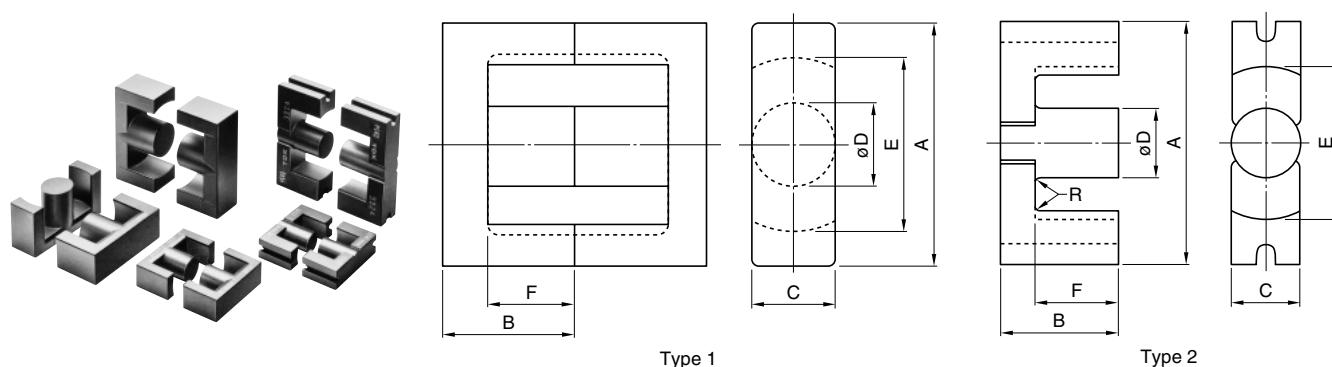

Part No.	JIS	Type	Dimensions in					
			mm inches					
			A	B	C	øD	E	F
PC40ETD19-Z		1	19.6±0.5 .771±.020	13.65±0.15 .537±.006	7.4±0.2 .291±.008	7.4±0.2 .291±.008	14.9±0.5 .586±.020	9.4±0.2 .370±.008
PC40ETD24-Z		1	24.4±0.6 .960±.024	14.45±0.15 .569±.006	8.5±0.4 .335±.016	8.5±0.2 .335±.008	18.6±0.6 .732±.024	10.1±0.2 .398±.008
PC40ETD29-Z		1	29.8±0.8 1.173±.031	15.80±0.15 .622±.006	9.5±0.3 .374±.012	9.5±0.3 .374±.012	22.7±0.7 .893±.028	11.0±0.3 .433±.012
PC40ETD34-Z	JIS FEER 34.2	1	34.2±0.8 1.346±.031	17.3±0.2 .681±.008	10.88±0.38 .428±.015	10.8±0.3 .425±.012	26.3±0.7 1.035±.028	12.1±0.3 .476±.012
PC40ETD39-Z	JIS FEER 39.1	1	39.1±0.9 1.539±.035	19.8±0.2 .780±.008	12.58±0.38 .495±.015	12.5±0.3 .492±.012	30.1±0.8 1.185±.031	14.6±0.4 .575±.016
PC40ETD44-Z	JIS FEER 44	1	44.0±1.0 1.732±.039	22.3±0.2 .878±.008	14.9±0.5 .587±.020	14.8±0.4 .583±.016	33.3±0.8 1.311±.031	16.5±0.4 .650±.016
PC40ETD49-Z	JIS FEER 48.7	1	48.7±1.1 1.917±.043	24.7±0.2 .972±.008	16.4±0.5 .646±.020	16.3±0.4 .642±.016	37.0±0.9 1.457±.035	18.1±0.4 .713±.016
PC40EC70-Z		2	70.0±1.7 2.756±.067	34.5±0.15 1.358±.006	16.4±0.4 .646±.016	16.4±0.4 .646±.016	44.5±1.2 1.752±.047	22.75±0.45 .896±.018
PC40EC90-Z		2	90.0±1.8 3.543±.071	45.0±1.3 1.772±.051	30.0±1.0 1.181±.039	30.0±1.0 1.181±.039	70.0±1.5 2.756±.059	35.5±0.5 1.398±.020
PC40EC120-Z		2	120±2.0 4.724±.079	50.5±1.0 1.988±.039	30.0±1.0 1.181±.039	30.0±1.0 1.181±.039	95.0±1.7 3.740±.067	35.5±0.5 1.398±.020

Part No.	Effective parameter				Electrical characteristics			Wt (g)	Bobbin item
	C ₁ (mm ⁻¹)	A _e (mm ²)	l _e (mm)	V _e (mm ³)	AL-value (nH/N ²)*		Core loss (W) max. 100kHz, 200mT, 100°C		
					Without air gap	With air gap			
PC40ETD19-Z	1.32	41.3	54.6	2260	1720±25%	80±5% 160±7%	1.1	14	BETD19-1111CPHFR
PC40ETD24-Z	1.100	56.3	61.9	3480	2125±25%	100±5% 200±7%	1.6	20	BETD24-1112CPHFR
PC40ETD29-Z	0.959	73.6	70.6	5170	2500±25%	200±5% 400±10%	2.4	28	—
PC40ETD34-Z	0.810	97.1	78.6	7630	2780±25%	200±5% 400±7%	3.31	40	—
PC40ETD39-Z	0.737	125	92.1	11500	3150±25%	200±5% 400±7%	5.3	60	—
PC40ETD44-Z	0.589	175	103	18000	4000±25%	250±5% 400±7%	8.3	94	—
PC40ETD49-Z	0.535	213	114	24300	4440±25%	250±5% 400±7%	11.2	124	—
PC40EC70-Z	0.514	279	144	40100	4800±25%	100±5% 200±5%	14.0	256	BEC-70-5116
PC40EC90-Z	0.346	624	216	135000	6000 min.		2.8**	698	BEC-90-0112
PC40EC120-Z	0.332	753	250	188250	6300 min.		3.5**	780	—

* AL-value: 1kHz, 0.5mA, 100Ts

** Core loss: 25kHz, 200mT, 100°C

EC AND ETD BOBBINS

Bobbin-core assembly dimensions

EC cores

ETD cores

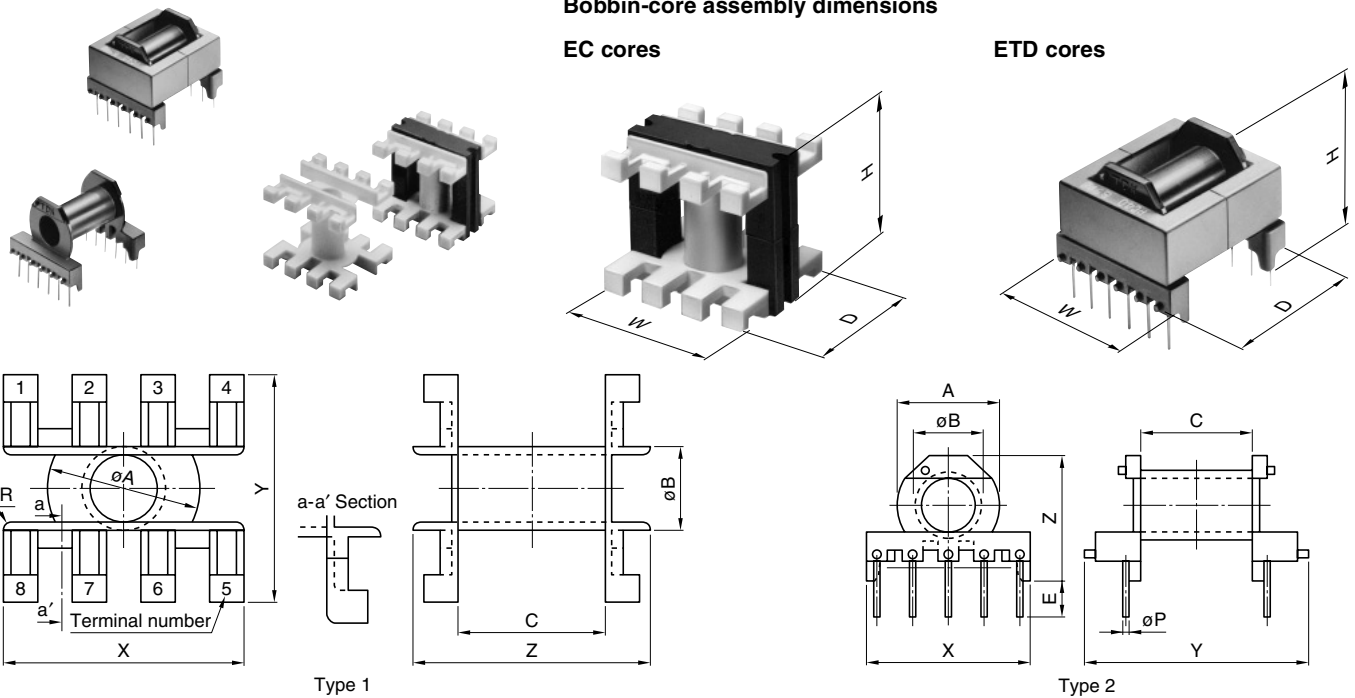

EC Bobbins

Part No.	Type	Dimensions in		C	X	Y	Z	t*	W D (mm) H
		mm	inches						
BEC-70-5116	1	42.7	19.5	41.45	70.0	56.25	57.8	1.13	72
		1.681	.768	1.632	2.756	2.214	2.276	.044	57
BEC-90-0112	1	67.6	35.4	65.3	80.0	77.0	89.8	1.90	92
		2.661	1.394	2.571	3.150	3.031	3.535	.075	77
									93

Part No.	Parameter		Wt (g)	Material	Accessory item
	Aw (mm ²)	ℓw (mm)			
BEC-70-5116	471.4	98	18	6-Nylon	—
BEC-90-0112	1046.5	162	82	6-Nylon	—

ETD Bobbins

Part No.	Type	Dimensions in		C	E	X	Y	Z	t*
		mm	inches						
BETD19-1111CPHFR	2	14.0	9.7	16.0	5.0	23.4	31.0	18.15	0.9
		.551	.382	.630	.197	.921	1.220	.715	.035
BETD24-1112CPHFR	2	17.5	10.9	17.2	5.0	29.0	33.6	21.65	0.9
		.689	.429	.677	.197	1.142	1.223	.852	.035

Part No.	Dimensions in mm					Terminal pins	Parameter			Wt (g)
	øP (mm)	P ₁ (mm)	P ₂ (mm)	P ₃ (mm)	W D (mm) H		Aw (mm ²)	ℓw (mm)		
BETD19-1111CPHFR	0.8	5.08	20.32	20.32	10	23.55 31.0 18.15	37.3	33.2	3.3	
BETD24-1112CPHFR	0.8	5.08	25.4	22.86	12	29.0 33.6 21.65	44.7	55.5	4.8	

UL Grade: 94V-0, Material: FR phenol, Pin material: Steel wire (Solder plated)

Maximum number of turns N that can be wound on bobbins, see section of "Maximum number of Turns on Bobbins".

* Minimum thickness of bobbin inside which core is placed, including flanges.

PLANAR CORES

Cores

- EL11/4 to EL25/8.6
- ELT11/3 to ELT25/8.6
- PQI16/7.8 to PQI26/11.5
- EIR14/4.5/9 to EIR22/5.5/15
- ER14/4.5/9 to ER22/5.5/15
- EI14/5/5 to EI22/8/16

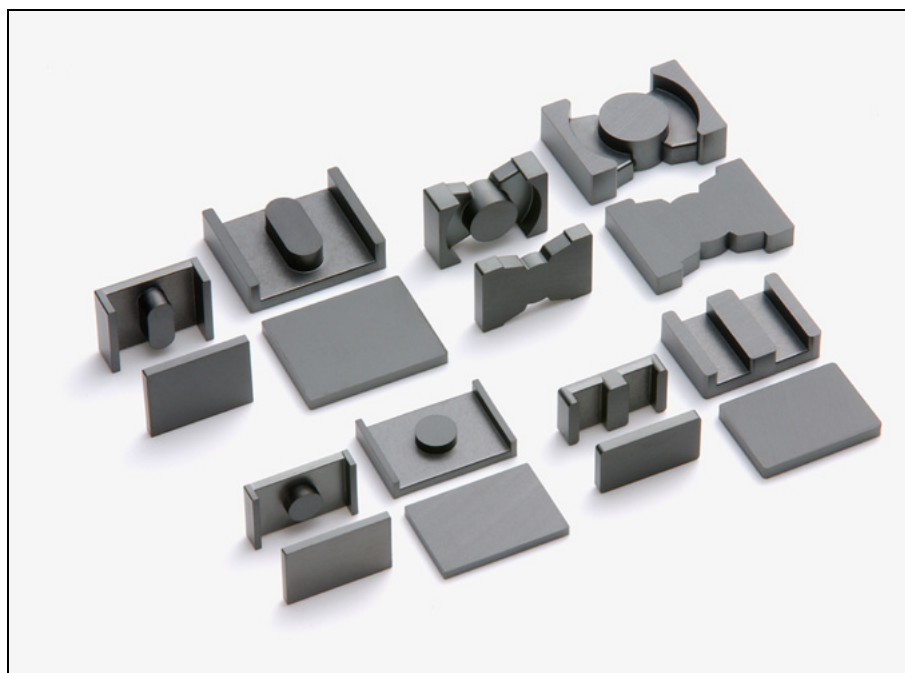

Ordering Code System

Cores

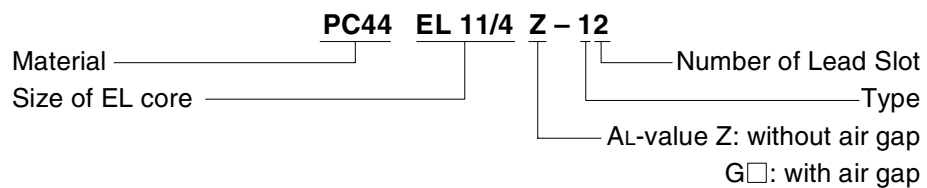

EL CORES

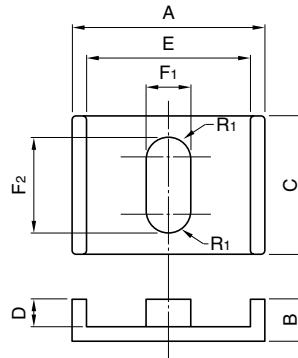
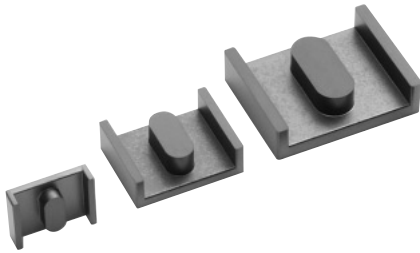

Part No.	Dimensions in							
	mm		inches					
	A	B	C	D	E	F1	F2	R1
PC44EL11/4-Z								
PC47EL11/4-Z	11.0±0.2	2.01±0.10	8.8±0.2	1.0±0.1	9.17±0.20	2.78±0.10	6.40±0.15	0.3
PC50EL11/4-Z	.433±.008	.079±.004	.346±.008	.039±.004	.361±.008	.109±.004	.252±.006	.012
PC33EL11/4-Z								
PC44EL13/4.4-Z								
PC47EL13/4.4-Z	13.00±0.25	2.19±0.10	10.4±0.2	1.0±0.1	10.83±0.20	3.29±0.10	7.56±0.15	0.3
PC50EL13/4.4-Z	.512±.010	.086±.004	.409±.008	.039±.004	.426±.008	.130±.004	.298±.006	.012
PC33EL13/4.4-Z								
PC44EL15.5/5.8-Z								
PC47EL15.5/5.8-Z	15.5±0.3	2.92±0.10	12.40±0.25	1.5±0.1	12.92±0.25	3.92±0.10	9.01±0.20	0.3
PC50EL15.5/5.8-Z	.610±.012	.115±.004	.488±.010	.059±.004	.509±.010	.154±.004	.355±.008	.012
PC33EL15.5/5.8-Z								
PC44EL18/7.3-Z								
PC47EL18/7.3-Z	18.0±0.3	3.65±0.10	14.40±0.25	2.0±0.1	15.0±0.3	4.55±0.10	10.47±0.20	0.3
PC50EL18/7.3-Z	.709±.012	.144±.004	.567±.010	.079±.004	.591±.012	.179±.004	.412±.008	.012
PC33EL18/7.3-Z								
PC44EL20/7.7-Z								
PC47EL20/7.7-Z	20.00±0.35	3.83±0.10	16.0±0.3	2.0±0.1	16.67±0.30	5.06±0.15	11.63±0.20	0.5
PC50EL20/7.7-Z	.787±.014	.151±.004	.630±.012	.079±.004	.656±.012	.199±.006	.458±.008	.020
PC33EL20/7.7-Z								

Part No.	Effective parameter							Electrical characteristics	
	C ₁	ℓ _e	A _e	V _e	A _{min.}	A _{cw}	Wt	A _L -value (nH/N ²)*	
	(mm ⁻¹)	(mm)	(mm ²)	(mm ³)	(mm ²)	(mm ²)	(g)	Without air gap	With air gap
PC44EL11/4-Z								1760±25%	50±3%
PC47EL11/4-Z								1790±25%	80±5%
PC50EL11/4-Z	0.825	13.7	16.6	227	16.1	6.39	1.4	1310±25%	125±7%
PC33EL11/4-Z								1310±25%	
PC44EL13/4.4-Z								2310±25%	63±3%
PC47EL13/4.4-Z								2360±25%	100±5%
PC50EL13/4.4-Z	0.666	15.4	23.2	358	22.5	7.55	2.2	1690±25%	160±7%
PC33EL13/4.4-Z								1690±25%	
PC44EL15.5/5.8-Z								2880±25%	63±3%
PC47EL15.5/5.8-Z								2950±25%	100±5%
PC50EL15.5/5.8-Z	0.597	19.6	32.9	645	32.0	13.5	3.9	2050±25%	160±7%
PC33EL15.5/5.8-Z								2050±25%	
PC44EL18/7.3-Z								3460±25%	80±3%
PC47EL18/7.3-Z								3550±25%	125±5%
PC50EL18/7.3-Z	0.538	23.8	44.3	1060	43.1	20.9	6.3	2400±25%	200±5%
PC33EL18/7.3-Z								2400±25%	
PC44EL20/7.7-Z								4090±25%	80±3%
PC47EL20/7.7-Z								4200±25%	125±5%
PC50EL20/7.7-Z	0.467	25.6	54.7	1400	53.2	23.2	8.3	2820±25%	200±5%
PC33EL20/7.7-Z								2820±25%	

* A_L-value: 1kHz, 0.5mA, 100Ts

EL CORES

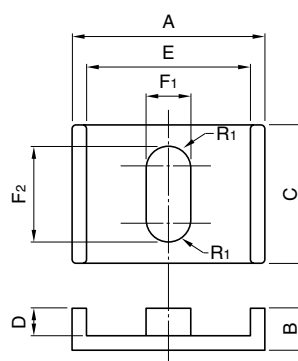
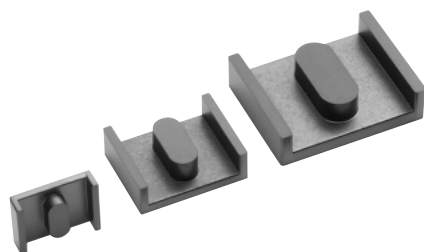

Part No.	Dimensions in		C	D	E	F ₁	F ₂	R ₁
	mm	inches						
PC44EL22/8-Z								
PC47EL22/8-Z	22.0±0.4	4.02±0.10	17.6±0.3	2.0±0.1	18.33±0.35	5.56±0.15	12.79±0.25	0.5
PC50EL22/8-Z	.866±.016	.158±.004	.693±.012	.079±.004	.722±.014	.219±.006	.504±.010	.020
PC33EL22/8-Z								
PC44EL25/8.6-Z								
PC47EL25/8.6-Z	25.00±0.45	4.29±0.10	20.00±0.35	2.0±0.1	20.83±0.35	6.32±0.15	14.54±0.25	0.5
PC50EL25/8.6-Z	.984±.018	.169±.004	.787±.014	.079±.004	.820±.014	.249±.006	.572±.010	.020
PC33EL25/8.6-Z								

Part No.	Effective parameter							Electrical characteristics	
	C ₁	ℓ _e	A _e	V _e	A _{min.}	A _{cw}	Wt	AL-value (nH/N ²)*	
	(mm ⁻¹)	(mm)	(mm ²)	(mm ³)	(mm ²)	(mm ²)	(g)	Without air gap	With air gap
PC44EL22/8-Z								4740±25%	
PC47EL22/8-Z								100±3%	
PC50EL22/8-Z	0.413	27.3	66.3	1810	64.4	25.5	10.8	160±3%	250±5%
PC33EL22/8-Z								3240±25%	
PC44EL25/8.6-Z								5770±25%	
PC47EL25/8.6-Z								100±3%	
PC50EL25/8.6-Z	0.350	85.7	30.0	2570	83.2	29.0	15.3	160±3%	250±5%
PC33EL25/8.6-Z								3900±25%	

* AL-value: 1kHz, 0.5mA, 100Ts

ELT CORES

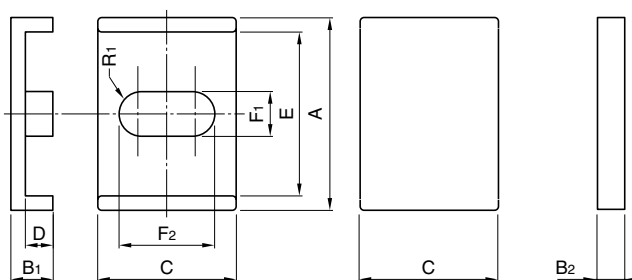
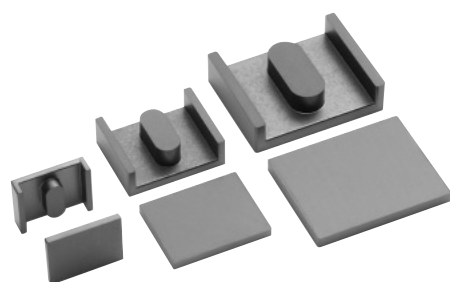

Part No.	Dimensions in								
	mm		inches						
	A	B1	B2	C	D	E	F1	F2	R1
PC44ELT11/3-Z									
PC47ELT11/3-Z	11.0±0.2	2.01±0.10	1.01±0.05	8.8±0.2	1.0±0.1	9.17±0.20	2.78±0.10	6.40±0.15	0.3
PC50ELT11/3-Z	.433±.008	.079±.004	.040±.002	.346±.008	.039±.004	.361±.008	.109±.004	.252±.006	.012
PC33ELT11/3-Z									
PC44ELT11/4-Z									
PC47ELT11/4-Z	11.0±0.2	3.01±0.10	1.01±0.05	8.8±0.2	2.0±0.1	9.17±0.20	2.78±0.10	6.40±0.15	0.3
PC50ELT11/4-Z	.433±.008	.119±.004	.040±.002	.346±.008	.079±.004	.361±.008	.109±.004	.252±.006	.012
PC33ELT11/4-Z									
PC44ELT13/3.4-Z									
PC47ELT13/3.4-Z	13.00±0.25	2.19±0.10	1.19±0.05	10.4±0.2	1.0±0.1	10.83±0.20	3.29±0.10	7.56±0.15	0.3
PC50ELT13/3.4-Z	.512±.010	.086±.004	.047±.002	.409±.008	.039±.004	.426±.008	.130±.004	.298±.006	.012
PC33ELT13/3.4-Z									
PC44ELT13/4.4-Z									
PC47ELT13/4.4-Z	13.00±0.25	3.19±0.10	1.19±0.05	10.4±0.2	2.0±0.1	10.83±0.20	3.29±0.10	7.56±0.15	0.3
PC50ELT13/4.4-Z	.512±.010	.126±.004	.047±.002	.409±.008	.079±.004	.426±.008	.130±.004	.298±.006	.012
PC33ELT13/4.4-Z									
PC44ELT15.5/4.3-Z									
PC47ELT15.5/4.3-Z	15.5±0.3	2.92±0.10	1.42±0.10	12.40±0.25	1.5±0.1	12.92±0.25	3.92±0.10	9.01±0.20	0.3
PC50ELT15.5/4.3-Z	.610±.012	.115±.004	.056±.004	.488±.010	.059±.004	.509±.010	.154±.004	.355±.008	.012
PC33ELT15.5/4.3-Z									

Part No.	Effective parameter							Electrical characteristics	
	C ₁	ℓ _e	A _e	V _e	A _{min.}	A _{cw}	Wt	A _L -value (nH/N ²)*	
	(mm ⁻¹)	(mm)	(mm ²)	(mm ³)	(mm ²)	(mm ²)	(g)	Without air gap	With air gap
PC44ELT11/3-Z								1890±25%	
PC47ELT11/3-Z								1930±25%	50±3%
PC50ELT11/3-Z								1440±25%	80±5%
PC33ELT11/3-Z								1440±25%	125±7%
PC44ELT11/4-Z								1530±25%	
PC47ELT11/4-Z								1570±25%	50±3%
PC50ELT11/4-Z								1110±25%	80±5%
PC33ELT11/4-Z								1110±25%	125±7%
PC44ELT13/3.4-Z								2480±25%	
PC47ELT13/3.4-Z								2530±25%	63±3%
PC50ELT13/3.4-Z								1850±25%	100±5%
PC33ELT13/3.4-Z								1850±25%	160±7%
PC44ELT13/4.4-Z								2040±25%	
PC47ELT13/4.4-Z								2080±25%	63±3%
PC50ELT13/4.4-Z								1450±25%	100±5%
PC33ELT13/4.4-Z								1450±25%	160±7%
PC44ELT15.5/4.3-Z								3170±25%	
PC47ELT15.5/4.3-Z								3240±25%	63±3%
PC50ELT15.5/4.3-Z								2300±25%	100±5%
PC33ELT15.5/4.3-Z								2300±25%	160±7%

* A_L-value: 1kHz, 0.5mA, 100Ts

ELT CORES

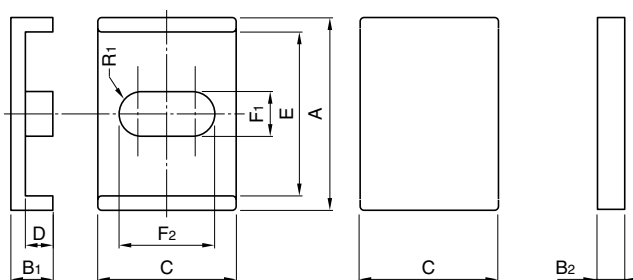
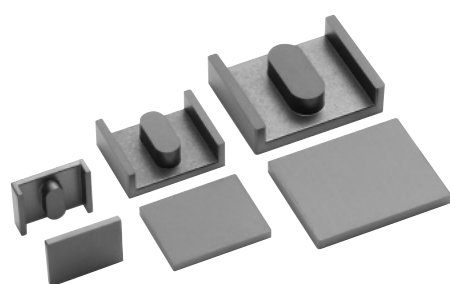

Part No.	Dimensions in									
	mm inches									
	A	B1	B2	C	D	E	F1	F2	R1	
PC44ELT15.5/5.8-Z										
PC47ELT15.5/5.8-Z	15.5±0.3	4.42±0.10	1.42±0.10	12.4±0.25	3.0±0.1	12.92±0.25	3.92±0.10	9.01±0.20	0.3	
PC50ELT15.5/5.8-Z	.610±.012	.174±.004	.056±.004	.488±.010	.118±.004	.509±.010	.154±.004	.355±.008	.012	
PC33ELT15.5/5.8-Z										
PC44ELT18/5.3-Z										
PC47ELT18/5.3-Z	18.0±0.3	3.65±0.10	1.65±0.10	14.4±0.25	2.0±0.1	15.0±0.3	4.55±0.10	10.47±0.20	0.3	
PC50ELT18/5.3-Z	.709±.012	.144±.004	.065±.004	.567±.010	.079±.004	.591±.012	.179±.004	.412±.008	.012	
PC33ELT18/5.3-Z										
PC44ELT18/7.3-Z										
PC47ELT18/7.3-Z	18.0±0.3	5.65±0.10	1.65±0.10	14.4±0.25	4.00±0.15	15.0±0.3	4.55±0.10	10.47±0.20	0.3	
PC50ELT18/7.3-Z	.709±.012	.222±.004	.065±.004	.567±.010	.157±.006	.591±.012	.179±.004	.412±.008	.012	
PC33ELT18/7.3-Z										
PC44ELT20/5.7-Z										
PC47ELT20/5.7-Z	20.00±0.35	3.83±0.10	1.83±0.10	16.0±0.3	2.0±0.1	16.67±0.30	5.06±0.15	11.63±0.20	0.5	
PC50ELT20/5.7-Z	.787±.014	.151±.004	.072±.004	.630±.012	.079±.004	.656±.012	.199±.006	.458±.008	.020	
PC33ELT20/5.7-Z										
PC44ELT20/7.7-Z										
PC47ELT20/7.7-Z	20.00±0.35	5.83±0.15	1.83±0.10	16.0±0.3	4.00±0.15	16.67±0.30	5.06±0.15	11.63±0.20	0.5	
PC50ELT20/7.7-Z	.787±.014	.230±.006	.072±.004	.630±.012	.157±.006	.656±.012	.199±.006	.458±.008	.020	
PC33ELT20/7.7-Z										

Part No.	Effective parameter							Electrical characteristics	
	C ₁	ℓ _e	A _e	V _e	A _{min.}	A _{cw}	Wt	A _L -value (nH/N ²) [*]	
	(mm ⁻¹)	(mm)	(mm ²)	(mm ³)	(mm ²)	(mm ²)	(g)	Without air gap	With air gap
PC44ELT15.5/5.8-Z								2450±25%	
PC47ELT15.5/5.8-Z								2510±25%	63±3%
PC50ELT15.5/5.8-Z	0.784	25.6	32.7	837	32.0	27.0	4.8	1680±25%	100±5%
PC33ELT15.5/5.8-Z								1680±25%	160±7%
PC44ELT18/5.3-Z								3880±25%	
PC47ELT18/5.3-Z								3970±25%	80±3%
PC50ELT18/5.3-Z	0.445	19.8	44.5	883	43.1	10.5	6.2	2750±25%	125±5%
PC33ELT18/5.3-Z								2750±25%	200±5%
PC44ELT18/7.3-Z								2860±25%	
PC47ELT18/7.3-Z								2940±25%	80±3%
PC50ELT18/7.3-Z	0.723	31.8	44.0	1400	43.1	41.8	7.5	1920±25%	125±5%
PC33ELT18/7.3-Z								1920±25%	200±5%
PC44ELT20/5.7-Z								4560±25%	
PC47ELT20/5.7-Z								4670±25%	80±3%
PC50ELT20/5.7-Z	0.392	21.6	55.0	1190	53.2	11.6	8.2	3200±25%	125±5%
PC33ELT20/5.7-Z								3200±25%	200±5%
PC44ELT20/7.7-Z								3400±25%	
PC47ELT20/7.7-Z								3500±25%	80±3%
PC50ELT20/7.7-Z	0.617	33.6	54.4	1830	53.2	46.4	9.8	2270±25%	125±5%
PC33ELT20/7.7-Z								2270±25%	200±5%

* A_L-value: 1kHz, 0.5mA, 100Ts

ELT CORES

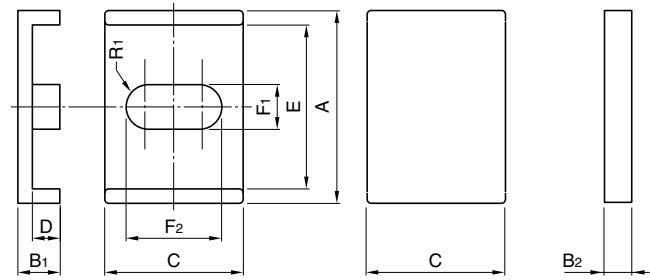
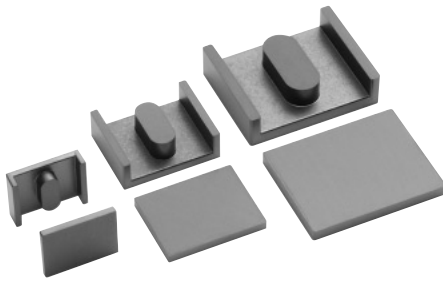

Part No.	Dimensions in								
	mm		inches						
	A	B1	B2	C	D	E	F1	F2	R1
PC44ELT22/6-Z									
PC47ELT22/6-Z	22.0±0.4	4.02±0.10	2.02±0.10	17.6±0.3	2.0±0.1	18.33±0.35	5.56±0.15	12.79±0.25	0.5
PC50ELT22/6-Z	.866±.016	.158±.004	.080±.004	.693±.012	.079±.004	.722±.014	.219±.006	.504±.010	.020
PC33ELT22/6-Z									
PC44ELT22/8-Z									
PC47ELT22/8-Z	22.0±0.4	6.02±0.15	2.02±0.10	17.6±0.3	4.00±0.15	18.33±0.35	5.56±0.15	12.79±0.25	0.5
PC50ELT22/8-Z	.866±.016	.237±.006	.080±.004	.693±.012	.157±.006	.722±.014	.219±.006	.504±.010	.020
PC33ELT22/8-Z									
PC44ELT25/6.6-Z									
PC47ELT25/6.6-Z	25.00±0.45	4.29±0.10	2.29±0.10	20.00±0.35	2.0±0.1	20.83±0.35	6.32±0.15	14.54±0.25	0.5
PC50ELT25/6.6-Z	.984±.018	.169±.004	.090±.004	.787±.014	.079±.004	.820±.014	.249±.006	.572±.010	.020
PC33ELT25/6.6-Z									
PC44ELT25/8.6-Z									
PC47ELT25/8.6-Z	25.00±0.45	6.29±0.15	2.29±0.10	20.00±0.35	4.00±0.15	20.83±0.35	6.32±0.15	14.54±0.25	0.5
PC50ELT25/8.6-Z	.984±.018	.248±.006	.090±.004	.787±.014	.157±.006	.820±.014	.249±.006	.572±.010	.020
PC33ELT25/8.6-Z									

Part No.	Effective parameter							Electrical characteristics	
	C ₁ (mm ⁻¹)	ℓ _e (mm)	A _e (mm ²)	V _e (mm ³)	A _{min.} (mm ²)	A _{cw} (mm ²)	Wt (g)	AL-value (nH/N ²)* Without air gap	With air gap
PC44ELT22/6-Z								5250±25%	
PC47ELT22/6-Z								5390±25%	100±3%
PC50ELT22/6-Z	0.351	23.3	66.6	1550	64.4	12.8	10.6	3660±25%	160±3%
PC33ELT22/6-Z								3660±25%	250±5%
PC44ELT22/8-Z								3970±25%	
PC47ELT22/8-Z								4090±25%	100±3%
PC50ELT22/8-Z	0.536	35.3	65.9	2330	64.4	51.1	12.6	2640±25%	160±3%
PC33ELT22/8-Z								2640±25%	250±5%
PC44ELT25/6.6-Z								6350±25%	
PC47ELT25/6.6-Z								6520±25%	100±3%
PC50ELT25/6.6-Z	0.302	26.0	86.1	2240	83.2	14.5	15.1	4370±25%	160±3%
PC33ELT25/6.6-Z								4370±25%	250±5%
PC44ELT25/8.6-Z								4870±25%	
PC47ELT25/8.6-Z								5020±25%	100±3%
PC50ELT25/8.6-Z	0.446	38.0	85.2	3230	83.2	58.0	17.7	3220±25%	160±3%
PC33ELT25/8.6-Z								3220±25%	250±5%

* AL-value: 1kHz, 0.5mA, 100Ts

PQI CORES

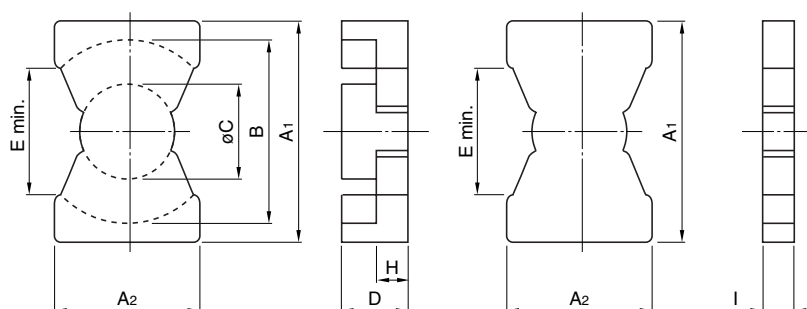
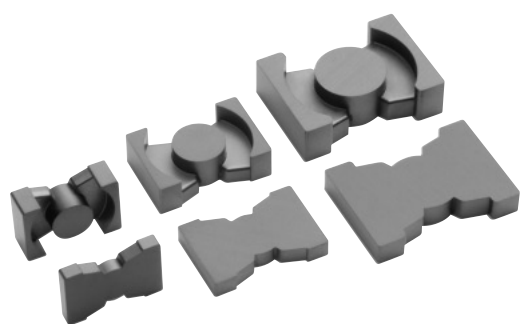

Part No.	Dimensions in		B	øC	D	E	H	I
	mm	inches						
	A1	A2						
PC44PQI16/7.8Z-12								
PC47PQI16/7.8Z-12	16.4±0.3	11.2±0.3	14.4±0.3	7.0±0.2	5.4±0.1	9.6min.	3.05±0.15	2.35±0.10
PC50PQI16/7.8Z-12	.646±.012	.441±.012	.567±.012	.276±.008	.213±.004	.378min.	.120±.006	.093±.004
PC33PQI16/7.8Z-12								
PC44PQI20/9Z-12								
PC47PQI20/9Z-12	20.5±0.4	14.0±0.4	18.0±0.4	8.8±0.2	6.0±0.1	12.0min.	3.05±0.15	2.95±0.10
PC50PQI20/9Z-12	.807±.016	.551±.016	.709±.016	.346±.008	.236±.004	.472min.	.120±.006	.116±.004
PC33PQI20/9Z-12								
PC44PQI26/11.5Z-12								
PC47PQI26/11.5Z-12	26.50±0.45	19.00±0.45	22.50±0.45	12.0±0.2	7.3±0.1	15.5min.	3.10±0.15	4.2±0.1
PC50PQI26/11.5Z-12	1.043±.018	.748±.018	.886±.018	.472±.008	.287±.004	.610min.	.122±.006	.165±.004
PC33PQI26/11.5Z-12								

Part No.	Effective parameter							Electrical characteristics	
	C ₁	ℓ _e	A _e	V _e	A _{min.}	A _{cw}	Wt	AL-value (nH/N ²)*	
	(mm ⁻¹)	(mm)	(mm ²)	(mm ³)	(mm ²)	(mm ²)	(g)	Without air gap	With air gap
PC44PQI16/7.8Z-12								3600±25%	63±3%
PC47PQI16/7.8Z-12	0.465	19.5	42.0	818	38.5	11.3	5.0	3710±25%	100±5%
PC50PQI16/7.8Z-12								2590±25%	160±7%
PC33PQI16/7.8Z-12								2590±25%	
PC44PQI20/9Z-12								5600±25%	
PC47PQI20/9Z-12	0.346	22.9	66.0	1509	60.8	14.0	9.0	5660±25%	100±3%
PC50PQI20/9Z-12								3670±25%	160±5%
PC33PQI20/9Z-12								3670±25%	250±7%
PC44PQI26/11.5Z-12								9700±25%	
PC47PQI26/11.5Z-12	0.224	27.7	123.0	3415	113.0	16.3	19.0	9700±25%	100±3%
PC50PQI26/11.5Z-12								5990±25%	160±5%
PC33PQI26/11.5Z-12								5990±25%	250±7%
								5990±25%	

* AL-value: 1kHz, 0.5mA, 100Ts

EIR CORES

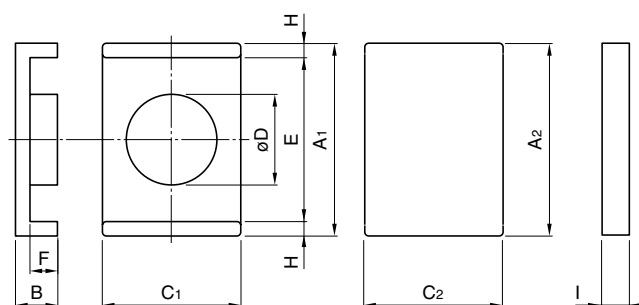
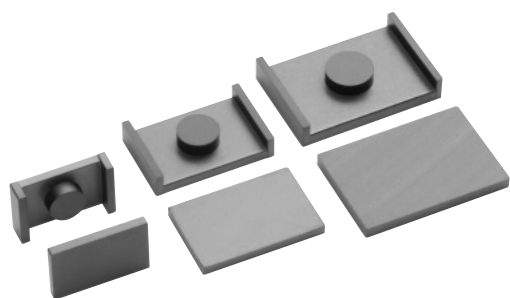

Part No.	Dimensions in										
	mm inches										
	A1	B	C1	øD	E	F	H	A2	C2	I	
PC44EIR14/4.5/9-Z											
PC47EIR14/4.5/9-Z	13.85±0.25	3.2±0.1	9.0±0.2	5.2±0.1	11.35±0.15	1.9±0.1	1.2	14.0±0.2	9.2±0.2	1.3±0.1	
PC50EIR14/4.5/9-Z	.545±.010	.126±.004	.354±.008	.205±.004	.447±.006	.075±.004	.047	.551±.008	.362±.008	.051±.004	
PC33EIR14/4.5/9-Z											
PC44EIR18/5/12-Z											
PC47EIR18/5/12-Z	18.15±0.30	3.5±0.1	12.0±0.2	6.0±0.1	15.75±0.25	2.0±0.1	1.2	18.20±0.25	12.2±0.2	1.5±0.1	
PC50EIR18/5/12-Z	.715±.012	.138±.004	.472±.008	.236±.004	.620±.010	.079±.004	.047	.717±.010	.480±.008	.059±.004	
PC33EIR18/5/12-Z											
PC44EIR22/5.5/15-Z											
PC47EIR22/5.5/15-Z	22.10±0.35	3.75±0.10	15.25±0.25	6.8±0.1	19.7±0.3	2.0±0.1	1.2	22.2±0.3	15.5±0.2	1.75±0.10	
PC50EIR22/5.5/15-Z	.870±.014	.148±.004	.600±.010	.268±.004	.776±.012	.079±.004	.047	.874±.012	.610±.008	.069±.004	
PC33EIR22/5.5/15-Z											

Part No.	Effective parameter							Electrical characteristics	
	C1	ℓ _e	A _e	V _e	A _{min.}	A _{cw}	Wt	AL-value (nH/N ²)	
	(mm ⁻¹)	(mm)	(mm ²)	(mm ³)	(mm ²)	(mm ²)	(g)	Without air gap	With air gap
PC44EIR14/4.5/9-Z								2400±25%	
PC47EIR14/4.5/9-Z								2400±25%	63±3%
PC50EIR14/4.5/9-Z	0.690	15.4	22.5	348	21.2	5.84	2.0	1800±25%	100±5%
PC33EIR14/4.5/9-Z								1800±25%	160±7%
PC44EIR18/5/12-Z								2900±25%	
PC47EIR18/5/12-Z								2950±25%	63±3%
PC50EIR18/5/12-Z	0.600	19.7	32.8	646	28.3	9.75	3.8	2100±25%	100±5%
PC33EIR18/5/12-Z								2100±25%	160±7%
PC44EIR22/5.5/15-Z								3400±25%	
PC47EIR22/5.5/15-Z								3430±25%	63±3%
PC50EIR22/5.5/15-Z	0.500	23.2	46.1	1071	36.3	12.9	6.5	2500±25%	100±5%
PC33EIR22/5.5/15-Z								2500±25%	160±7%

* AL-value: 1kHz, 0.5mA, 100Ts

ER CORES

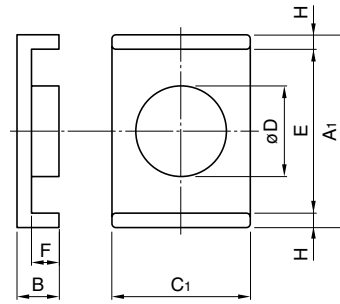
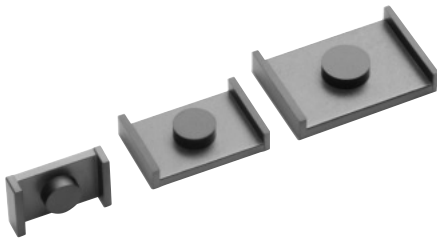

Part No.	Dimensions in		C ₁	øD	E	F	H
	mm	inches					
PC44ER14/4.5/9-Z							
PC47ER14/4.5/9-Z	13.85±0.25	2.25±0.10	9.0±0.2	5.2±0.1	11.35±0.15	0.95±0.10	1.2
PC50ER14/4.5/9-Z	.545±.010	.089±.004	.354±.008	.205±.004	.447±.006	.037±.004	.047
PC33ER14/4.5/9-Z							
PC44ER18/5/12-Z							
PC47ER18/5/12-Z	18.15±0.30	2.5±0.1	12.0±0.2	6.0±0.1	15.75±0.25	1.0±0.1	1.2
PC50ER18/5/12-Z	.715±.012	.098±.004	.472±.008	.236±.004	.620±.010	.039±.004	.047
PC33ER18/5/12-Z							
PC44ER22/5.5/15-Z							
PC47ER22/5.5/15-Z	22.10±0.35	2.75±0.10	15.25±0.25	6.8±0.1	19.7±0.3	1.0±0.1	1.2
PC50ER22/5.5/15-Z	.870±.014	.108±.004	.600±.010	.268±.004	.776±.012	.039±.004	.047
PC33ER22/5.5/15-Z							

Part No.	Effective parameter							Electrical characteristics	
	C ₁	∅e	A _e	V _e	A _{min.}	A _{cw}	Wt	A _L -value (nH/N ²)*	
	(mm ⁻¹)	(mm)	(mm ²)	(mm ³)	(mm ²)	(mm ²)	(g)	Without air gap	With air gap
PC44ER14/4.5/9-Z								2400±25%	
PC47ER14/4.5/9-Z								2400±25%	63±3%
PC50ER14/4.5/9-Z	0.690	15.4	22.5	348	21.2	5.84	2.0	1640±25%	100±5%
PC33ER14/4.5/9-Z								1640±25%	160±7%
PC44ER18/5/12-Z								2900±25%	
PC47ER18/5/12-Z								3000±25%	63±3%
PC50ER18/5/12-Z	0.602	19.7	32.8	646	28.3	9.75	3.8	1960±25%	100±5%
PC33ER18/5/12-Z								1960±25%	160±7%
PC44ER22/5.5/15-Z								3400±25%	
PC47ER22/5.5/15-Z								3430±25%	63±3%
PC50ER22/5.5/15-Z	0.505	23.2	46.1	1071	36.3	12.9	6.5	2390±25%	100±5%
PC33ER22/5.5/15-Z								2390±25%	160±7%

* A_L-value: 1kHz, 0.5mA, 100Ts

EI CORES

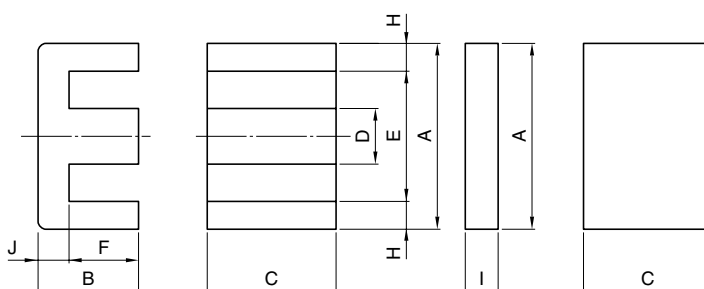
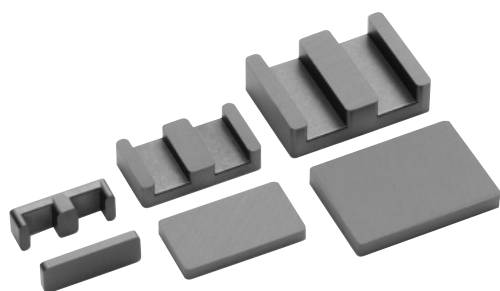

Part No.	Dimensions in		C	D	E	F	H	I	J
	mm	inches							
PC44E114/5/5-Z									
PC47E114/5/5-Z	14.0±0.3	3.5±0.1	5.0±0.1	3.0±0.1	11.00±0.25	2.0±0.1	1.5	1.50±0.05	1.5
PC50E114/5/5-Z	.551±.012	.138±.004	.197±.004	.118±.004	.433±.010	.079±.004	.059	.059±.002	.059
PC33E114/5/5-Z									
PC44E118/6/10-Z									
PC47E118/6/10-Z	18.15±0.35	4.0±0.1	10.0±0.2	4.0±0.1	14.0±0.3	2.0±0.1	2.0	2.00±0.05	2.0
PC50E118/6/10-Z	.715±.014	.157±.004	.394±.008	.157±.004	.551±.012	.079±.004	.079	.079±.002	.079
PC33E118/6/10-Z									
PC44E122/8/16-Z									
PC47E122/8/16-Z	21.80±0.4	5.7±0.1	15.8±0.3	5.0±0.1	16.8±0.4	3.2±0.1	2.5	2.50±0.05	2.5
PC50E122/8/16-Z	.858±.016	.224±.004	.622±.012	.197±.004	.661±.016	.126±.004	.098	.098±.002	.098
PC33E122/8/16-Z									

Part No.	Effective parameter							Electrical characteristics	
	C ₁	ℓ _e	A _e	V _e	A _{min.}	A _{cw}	Wt	AL-value (nH/N ²)*	
	(mm ⁻¹)	(mm)	(mm ²)	(mm ³)	(mm ²)	(mm ²)	(g)	Without air gap	With air gap
PC44E114/5/5-Z								1400±25%	63±3%
PC47E114/5/5-Z								1450±25%	100±5%
PC50E114/5/5-Z	1.114	16.7	15.0	251	15.0	8.00	2.0	1020±25%	160±7%
PC33E114/5/5-Z								1020±25%	
PC44E118/6/10-Z								3480±25%	100±3%
PC47E118/6/10-Z								3560±25%	160±5%
PC50E118/6/10-Z	0.507	20.3	40.0	811	40.0	10.0	6.0	2450±25%	250±7%
PC33E118/6/10-Z								2450±25%	
PC44E122/8/16-Z								5900±25%	160±3%
PC47E122/8/16-Z								5900±25%	250±3%
PC50E122/8/16-Z	0.330	26.1	79.0	2060	79.0	18.9	14.3	4300±25%	315±3%
PC33E122/8/16-Z								4300±25%	

* AL-value: 1kHz, 0.5mA, 100Ts

ORIGINAL CORES

Cores

PQ20/16 to PQ50/50

LP23/8 to LP32/13

EPC10 to EPC30

EP7 to EP20

Bobbins

BPQ20/16 to BPQ50/50

BLP23/8 to BLP32/13

BEPC10 to BEPC30

BEP7 to BEP20

Accessories

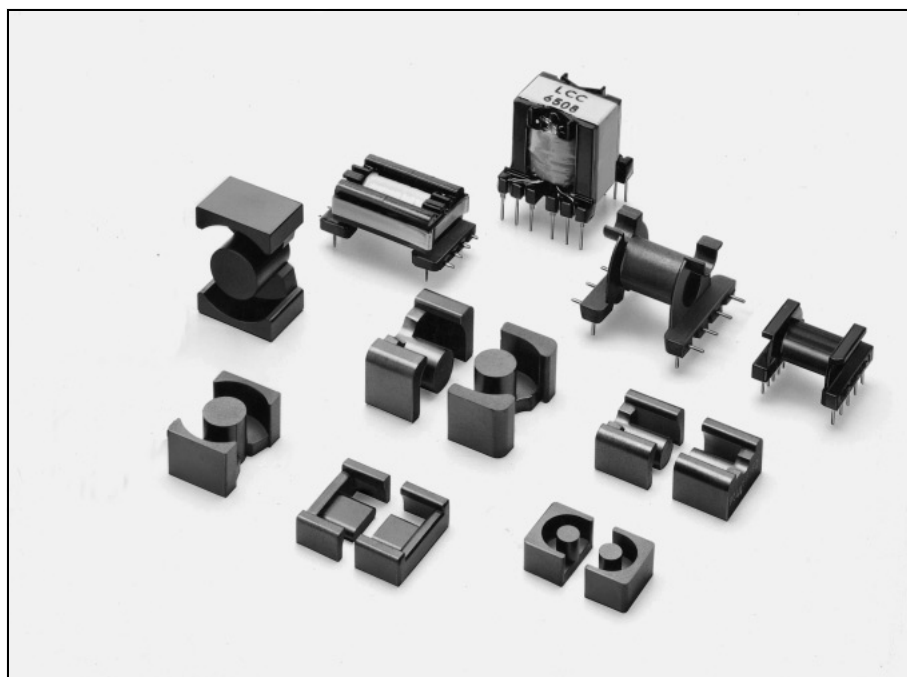

Ordering Code System

Cores

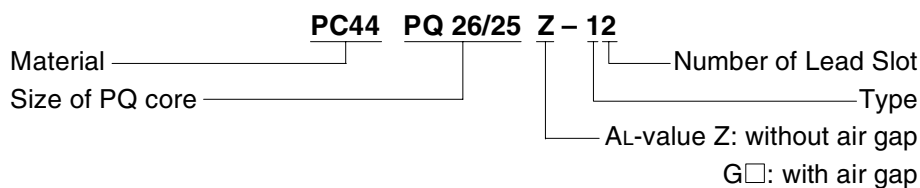

Bobbins

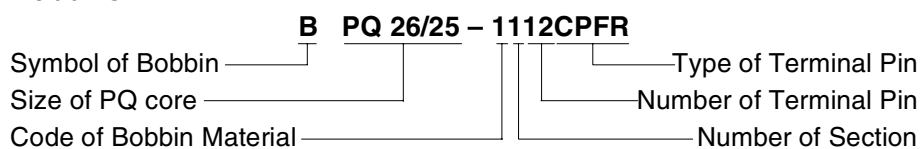

Accessories

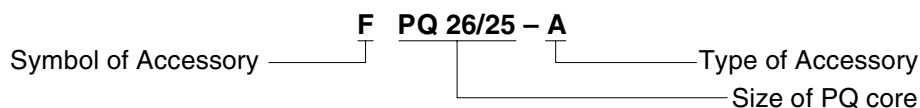

PQ CORES

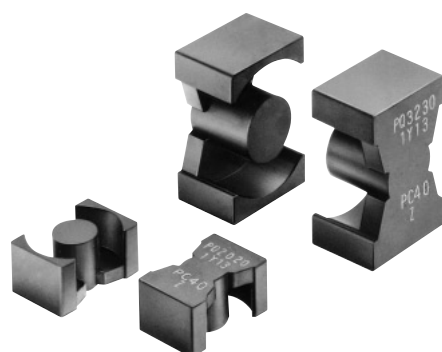

DE. PAT. 2,944,583
 DE. DES. 15,655
 EP. PAT. 26,104(DE, FR, GB, NL)
 GB. PAT. 2,035,706
 GB. DES. 990,685
 JP. U. M 1,589,580
 JP. U. M 1,621,895
 JP. U. M PUB.
 85(60)-3556 1,647,781
 JP. U. M PUB.
 86(61)-5779 1655608
 JP. DES. 580,081
 JP. DES. 649,618
 KR. U. M 23,487
 NL. PAT. 178,826
 NL. DES. 5,777
 US. PAT. 4,352,080
 US. DES. 264,959

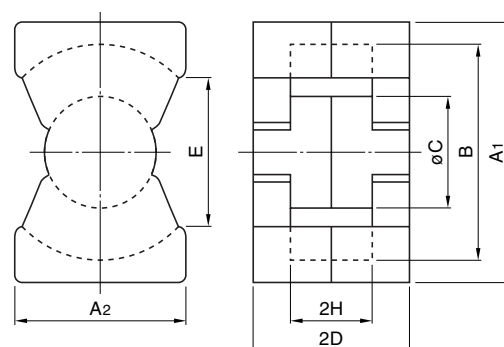

Part No.	Dimensions in		B	øC	2D	E	2H
	mm	inches					
	A1	A2				min.	
PC44PQ20/16Z-12	20.5±0.4 .807±.016	14.0±0.4 .551±.016	18.0±0.4 .709±.016	8.8±0.2 .346±.008	16.2±0.2 .638±.008	12.0 .472	10.3±0.3 .406±.012
PC44PQ20/20Z-12	20.5±0.4 .807±.016	14.0±0.4 .551±.016	18.0±0.4 .709±.016	8.8±0.2 .346±.008	20.2±0.2 .795±.008	12.0 .472	14.3±0.3 .563±.012
PC50PQ20/20Z-12	20.5±0.4 .807±.016	14.0±0.4 .551±.016	18.0±0.4 .709±.016	8.8±0.2 .346±.008	20.2±0.2 .795±.008	12.0 .472	14.3±0.3 .563±.012
PC44PQ26/20Z-12	26.5±0.45 1.043±.018	19.0±0.45 .748±.018	22.5±0.45 .886±.018	12.0±0.2 .472±.008	20.15±0.25 .793±.010	15.5 .610	11.5±0.3 .453±.012
PC44PQ26/25Z-12	26.5±0.45 1.043±.018	19.0±0.45 .748±.018	22.5±0.45 .886±.018	12.0±0.2 .472±.008	24.75±0.25 .974±.010	15.5 .610	16.1±0.3 .634±.012
PC50PQ26/25Z-12	26.5±0.45 1.043±.018	19.0±0.45 .748±.018	22.5±0.45 .886±.018	12.0±0.2 .472±.008	24.75±0.25 .974±.010	15.5 .610	16.1±0.3 .634±.012
PC44PQ32/20Z-12	32.0±0.5 1.260±.020	22.0±0.5 .866±.020	27.5±0.5 1.083±.020	13.45±0.25 .530±.010	20.55±0.25 .809±.010	19.0 .748	11.5±0.3 .453±.012
PC44PQ32/30Z-12	32.0±0.5 1.260±.020	22.0±0.5 .866±.020	27.5±0.5 1.083±.020	13.45±0.25 .530±.010	30.35±0.25 1.195±.010	19.0 .748	21.3±0.3 .839±.012

Part No.	Effective parameter				Electrical characteristics		Core loss (W) max. 100kHz, 200mT, 100°C	Wt (g)	Bobbin item
	C ₁ (mm ⁻¹)	A _e (mm ²)	l _e (mm)	V _e (mm ³)	AL-value (nH/N ²) [*]				
					Without air gap	With air gap			
PC44PQ20/16Z-12	0.603	62	37.4	2320	3880±25%	100±5% 250±7% 400±10%	0.84	13	BPQ20/16-1114CPFR
PC44PQ20/20Z-12	0.732	62	45.4	2810	3150±25%	100±5% 250±7% 400±10%	1.02	15	BPQ20/20-1114CPFR
PC50PQ20/20Z-12	0.732	62	45.4	2810	2000±25%	100±5% 160±5% 250±7%	0.33***	15	BPQ20/20-1114CPFR
PC44PQ26/20Z-12	0.389	119	46.3	5510	6170±25%	160±5% 315±5% 630±10%	1.94	31	BPQ26/20-1112CPFR
PC44PQ26/25Z-12	0.470	118	55.5	6550	5250±25%	160±5% 315±5% 630±10%	2.32	36	BPQ26/25-1112CPFR
PC50PQ26/25Z-12	0.470	118	55.5	6550	3200±25%	100±5% 250±5% 400±7%	0.76***	36	BPQ26/25-1112CPFR
PC44PQ32/20Z-12	0.326	170	55.5	9440	7310±25%	160±5% 315±5% 630±7%	2.92	42	BPQ32/20-1112CPFR
PC44PQ32/30Z-12	0.463	161	74.6	12000	5140±25%	160±5% 315±5% 630±7%	3.92	55	BPQ32/30-1112CPFR

* AL-value: 1kHz, 0.5mA, 100Ts

** Core loss: 100kHz, 150mT, 100°C

*** Core loss: 500kHz, 50mT, 100°C

PQ CORES



DE. PAT. 2,944,583
 DE. DES. 15,655
 EP. PAT. 26,104(DE, FR, GB, NL)
 GB. PAT. 2,035,706
 GB. DES. 990,685
 JP. U. M 1,589,580
 JP. U. M 1,621,895
 JP. U. M PUB.
 85(60)-3556 1,647,781
 JP. U. M PUB.
 86(61)-5779 1655608
 JP. DES. 580,081
 JP. DES. 649,618
 KR. U. M 23,487
 NL. PAT. 178,826
 NL. DES. 5,777
 US. PAT. 4,352,080
 US. DES. 264,959

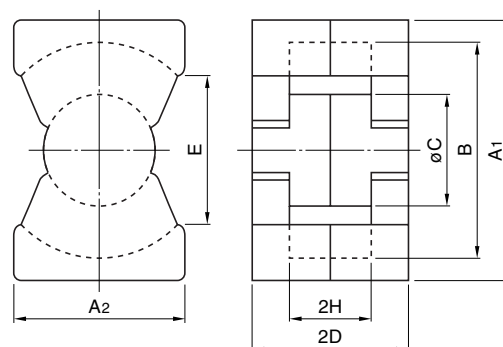

Part No.	Dimensions in		B	øC	2D	E	2H
	mm	inches					
PC44PQ35/35Z-12	35.1±0.6	26.0±0.5	32.0±0.5	14.35±0.25	34.75±0.25	23.5	25.0±0.3
	1.382±.024	1.024±.020	1.260±.020	.565±.010	1.368±.010	.925	.984±.012
PC44PQ40/40Z-12	40.5±0.9	28.0±0.6	37.0±0.6	14.9±0.3	39.75±0.25	28.0	29.5±0.3
	1.594±.035	1.102±.024	1.457±.024	.587±.012	1.565±.010	1.102	1.161±.012
PC44PQ50/50Z-12	50.0±0.7	32.5±0.5	44.0±0.7	20.0±0.35	49.95±0.25	31.5	36.1±0.3
	1.969±.028	1.260±.020	1.732±.028	.787±.014	1.967±.010	1.240	1.421±.012

Part No.	Effective parameter				Electrical characteristics			Wt (g)	Bobbin item
	C ₁ (mm ⁻¹)	A _e (mm ²)	l _e (mm)	V _e (mm ³)	AL-value (nH/N ²)*		Core loss (W) max. 100kHz, 200mT, 100°C		
					Without air gap	With air gap			
PC44PQ35/35Z-12	0.448	196	87.9	17200	4860±25%	160±5% 315±5% 630±7%	5.27	73	BPQ35/35-1112CPFR
PC44PQ40/40Z-12	0.507	201	102	20500	4300±25%	160±5% 315±5% 630±7%	6.56	95	BPQ40/40-1112CPFR
PC44PQ50/50Z-12	0.346	328	113	37238	6720±25%	250±5% 400±5% 630±5%	6.10**	195	BPQ50/50-1112CPFR

* AL-value: 1kHz, 0.5mA, 100Ts

** Core loss: 100kHz, 150mT, 100°C

*** Core loss: 500kHz, 50mT, 100°C

PQ BOBBINS

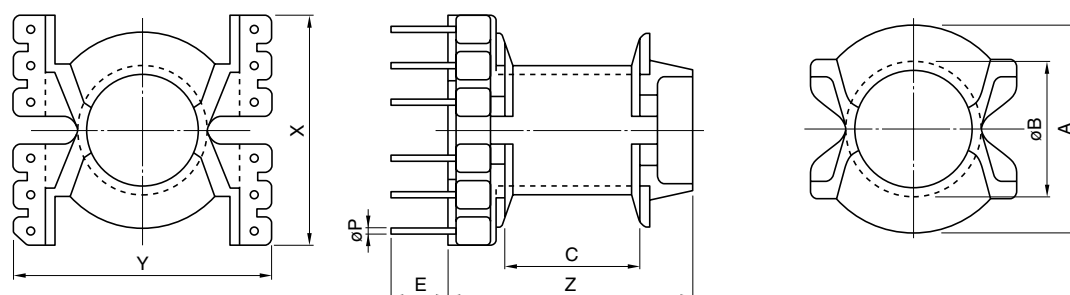

Part No.	Dimensions in							
	mm		inches					
	A	ØB	C	E	X	Y	Z	t*
BPQ20/16-1114CPFR	17.2 .677	10.95 .431	8.0 .315	6.5 .256	23.0 .906	23.0 .906	18.3 .720	0.8 .031
BPQ20/20-1114CPFR	17.2 .677	10.95 .431	12.0 .472	6.5 .256	23.0 .906	23.0 .906	22.3 .878	0.8 .031
BPQ26/20-1112CPFR	21.6 .850	14.3 .563	9.2 .362	6.5 .256	26.5 1.043	29.3 1.154	21.5 .846	0.8 .031
BPQ26/25-1112CPFR	21.6 .850	14.3 .563	13.9 .547	3.5 .138	26.5 1.043	29.3 1.154	29.1 1.146	0.8 .031
BPQ32/20-1112CPFR	26.6 1.047	16.0 .630	9.0 .354	7.0 .276	32.0 1.260	34.0 1.339	22.5 .886	0.9 .035
BPQ32/30-1112CPFR	26.6 1.047	16.0 .630	18.6 .732	7.0 .276	32.0 1.260	34.0 1.339	32.1 1.264	0.9 .035
BPQ35/35-1112CPFR	31.1 1.224	16.9 .665	22.4 .882	7.5 .295	35.0 1.378	39.0 1.535	37.4 1.472	0.9 .035
BPQ40/40-1112CPFR	36.0 1.417	17.5 .689	26.8 1.055	6.5 .256	40.0 1.575	42.0 1.654	44.8 1.764	0.9 .035
BPQ50/50-1112CPFR	42.9 1.689	23.2 .913	32.4 1.276	10.0 .394	51.0 2.008	51.0 2.008	52.0 2.047	1.0 .039

Part No.	Dimensions in mm			Parameter		Wt (g)	Accessory item
	ØP (mm)	Terminal pins	W D (mm) H	Aw (mm ²)	ℓ w (mm)		
BPQ20/16-1114CPFR	0.6	14	23.0 23.0 18.3	23.4	44	2.7	FPQ20/16-A
BPQ20/20-1114CPFR	0.6	14	23.0 23.0 22.3	36.2	44	2.8	FPQ20/20-A
BPQ26/20-1112CPFR	0.8	12	26.5 29.3 21.5	30.7	56.2	4.3	FPQ26/20-A
BPQ26/25-1112CPFR	0.8	12	26.5 29.3 29.1	47.7	56.2	4.9	FPQ26/25-A
BPQ32/20-1112CPFR	1.0	12	32.0 34.0 22.5	42.9	67.1	6.6	FPQ32/20-A
BPQ32/30-1112CPFR	1.0	12	32.0 34.0 32.1	95.3	67.1	7.4	FPQ32/30-A
BPQ35/35-1112CPFR	1.0	12	35.0 39.0 37.4	154.2	75.2	11	FPQ35/35-A
BPQ40/40-1112CPFR	1.0	12	40.0 42.0 44.8	240.0	83.9	14	FPQ40/40-A
BPQ50/50-1112CPFR	1.2	12	51.0 51.0 52.0	313.0	104	22	FPQ50/50-B

UL Grade: 94V-0, Material: FR phenol, Pin material: Steel wire (Solder plated)

Maximum number of turns N that can be wound on bobbins, see section of "Maximum number of Turns on Bobbins".

* Minimum thickness of bobbin inside which core is placed, including flanges.

Connecting Pin Patterns (2.54mm/0.1 inch grids) View in mounting direction

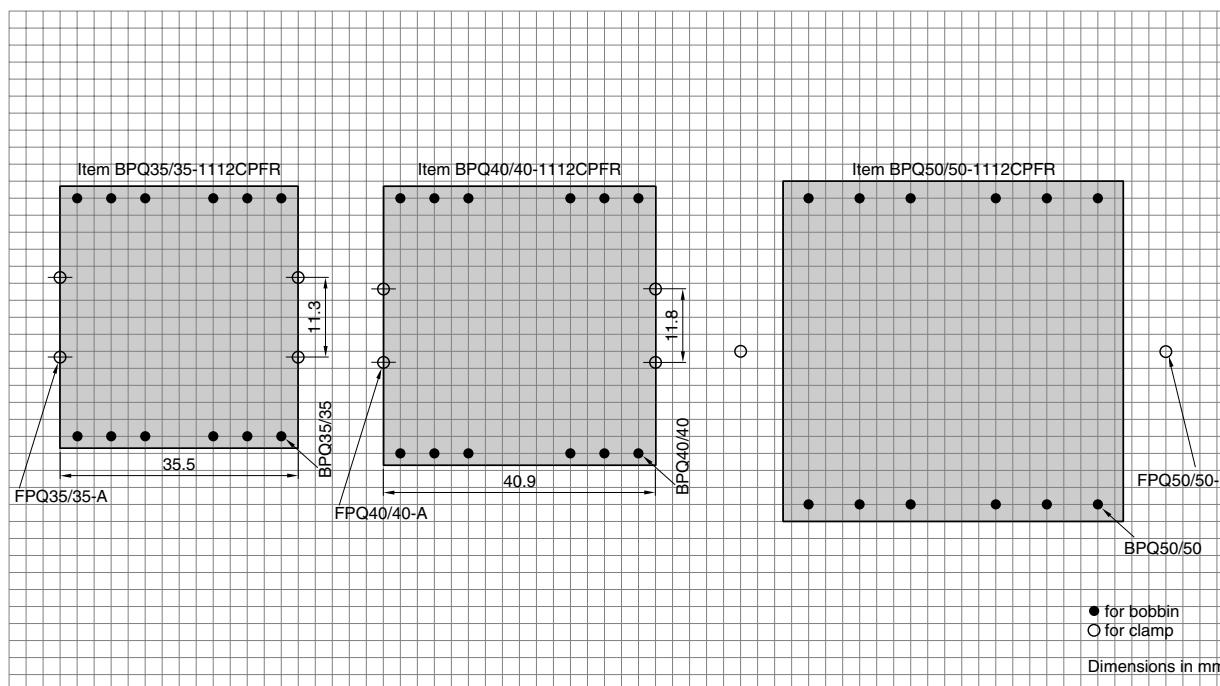
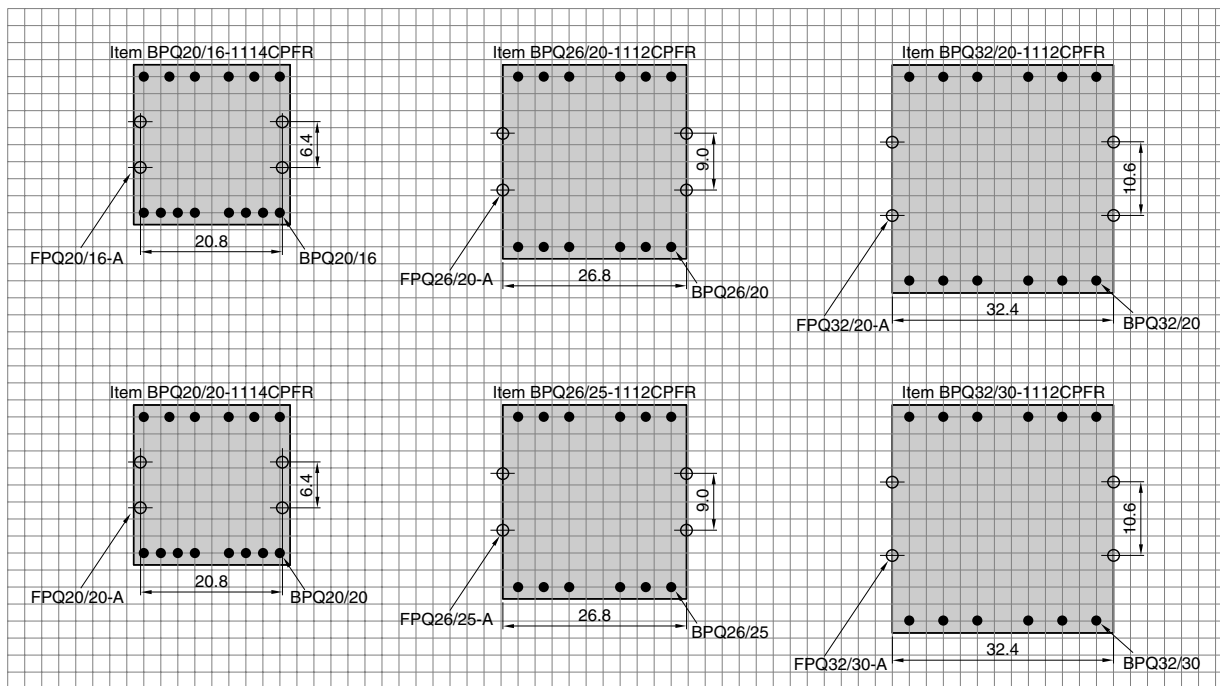

• All specifications are subject to change without notice.

LP CORES

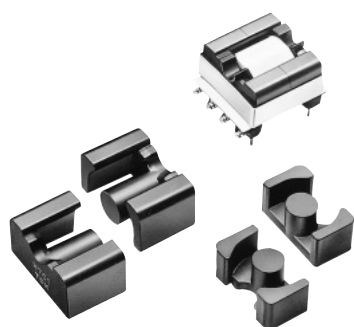

DE. DES. 19,581
 EP. PAT. 68,745(DE, FR, GB, NL)
 FR. DES. 201,586
 GB. DES. 1,007,200
 JP. U. M PRO. PUB. 82(57)-201,824
 JP. DES. 630,754
 NL. DES. 9,767
 US. PAT. 4,424,504
 US. DES. 280,810

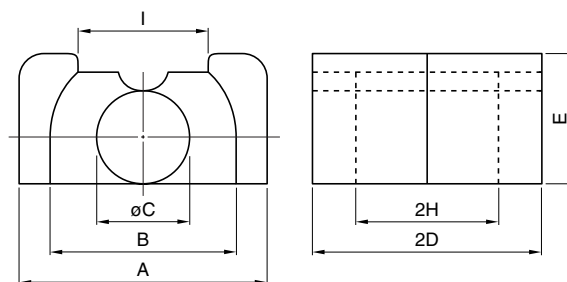

Part No.	Dimensions in		øC	2D	E	2H	I
	mm	inches					
	A	B					
PC44LP23/8Z-12	16.5±0.3 .650±.012	12.5±0.3 .492±.012	5.7±0.1 .224±.004	23.4±0.2 .921±.008	8.7±0.2 .343±.008	17.4±0.2 .685±.008	9.0±0.5 .354±.020
PC44LP22/13Z-12	25.0±0.4 .984±.016	19.0±0.3 .748±.012	8.6±0.2 .339±.008	22.4±0.2 .882±.008	12.9±0.3 .508±.012	16.4±0.3 .646±.012	13.5±0.5 .531±.020
PC44LP32/13Z-12	25.0±0.4 .984±.016	19.0±0.3 .748±.012	8.6±0.2 .339±.008	31.8±0.2 1.252±.008	12.9±0.3 .508±.012	24.1±0.3 .949±.012	13.5±0.5 .531±.020

Part No.	Effective parameter				Electrical characteristics			Wt (g)	Bobbin item
	C ₁ (mm ⁻¹)	A _e (mm ²)	l _e (mm)	V _e (mm ³)	AL-value (nH/N ²)*		Core loss (W) max. 100kHz, 200mT, 100°C		
					Without air gap	With air gap			
PC44LP23/8Z-12	1.41	31.3	44.1	1380	1600±25%	63±5% 100±7% 250±13%	0.42	9.6	BLP23/8-018PFR
PC44LP22/13Z-12	0.721	67.9	49.0	3330	3310±25%	100±5% 200±7% 400±10%	1.05	21	BLP22/13-1110CPLFR
PC44LP32/13Z-12	0.909	70.3	64.0	4500	2630±25%	100±5% 200±7% 400±10%	1.38	30	BLP32/13-1110CPLFR

* AL-value: 1kHz, 0.5mA, 100Ts

LP BOBBINS

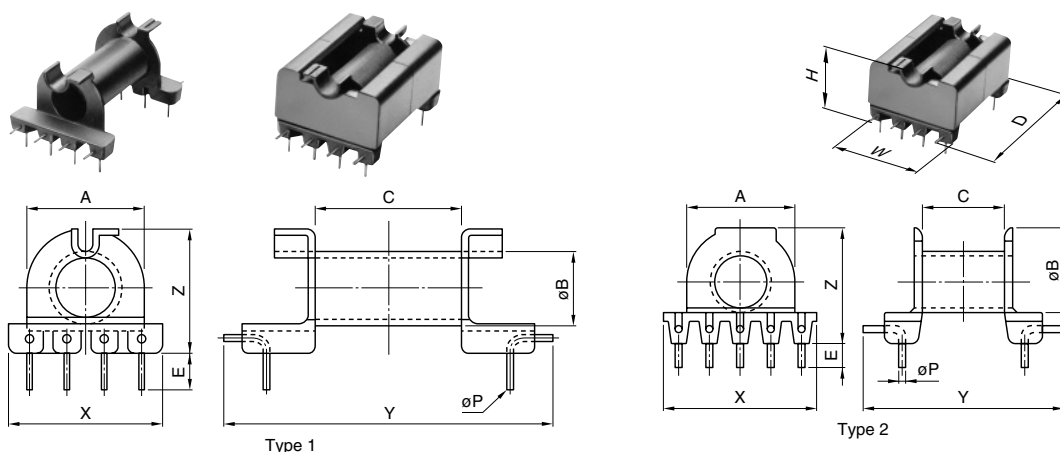

Part No.	Type	Dimensions in							
		mm		inches					
		A	B	C	E	X	Y	Z	t**
BLP23/8-018CPLFR	1	12.0 .472	7.7 .303	15.2 .598	4.0 .157	16.5 .650	34.0 1.358	12.5 .492	0.8 .031
BLP22/13-018CPLFR	1	17.6 .693	10.7 .421	14.1 .555	4.0 .157	25.0 .984	31.5 1.240	17.6 .693	0.8 .031
BLP22/13-1110CPLFR*	2	17.6 .693	10.78 .424	13.4 .528	4.0 .157	25.0 .984	32.3 1.272	19.1 .752	0.8 .031
BLP32/13-018CPLFR	1	17.6 .693	10.7 .421	21.8 .858	4.0 .157	25.0 .984	40.4 1.591	17.6 .693	0.8 .031
BLP32/13-1110CPLFR*	2	17.6 .693	10.82 .426	21.1 .835	4.0 .157	25.0 .984	40.6 1.598	19.1 .752	0.8 .031

Part No.	Dimensions in mm			Parameter		Wt (g)	Material	Clamp item
	øP (mm)	Terminal pins	W D (mm) H	Aw (mm ²)	ℓ w (mm)			
BLP23/8-018CPLFR	0.6	8	17.2 34.2 12.5	31.9	30.9	1.9	PPS	FLP23/8-A
BLP22/13-018CPLFR	0.8	8	27 32 17.8	51.5	45.8	3.2	PPS	FLP22/13-A
BLP22/13-1110CPLFR*	0.8	10	25.9 32.3 19.2	45.7	44.5	3.1	FR Phenol	FLP22/13-A
BLP32/13-018CPLFR	0.8	8	27 41 17.8	79.6	45.8	3.7	PPS	FLP32/13-A
BLP32/13-1110CPLFR*	0.8	10	25.9 40.6 19.2	72.0	44.5	3.7	FR Phenol	FLP32/13-A

UL Grade: 94V-0, Pin material: Phosphor bronze wire/Steel wire for "-1110-CPLFR" (Solder plated), Insulating divider's material: NOMEX®
 Maximum number of turns N that can be wound on bobbins, see section of "Maximum number of Turns on Bobbins".

* Include 2 pieces of insulating dividers.

Insulating divider for BLP22/13-1110CPLFR
 Part No.: ILP22/13

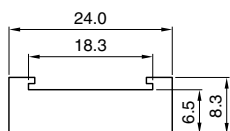

Insulating divider for BLP32/13-1110CPLFR
 Part No.: ILP32/13

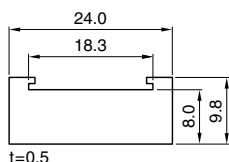

Dimensions in mm

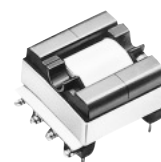

** Minimum thickness of bobbin inside which core is placed, including flanges.

PIN LAYOUT

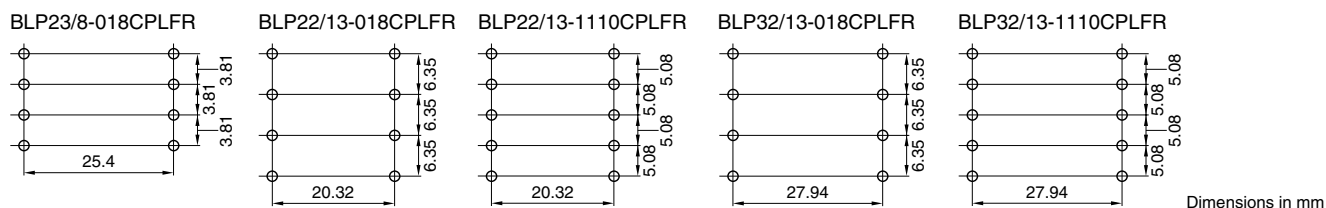

• All specifications are subject to change without notice.

EPC CORES

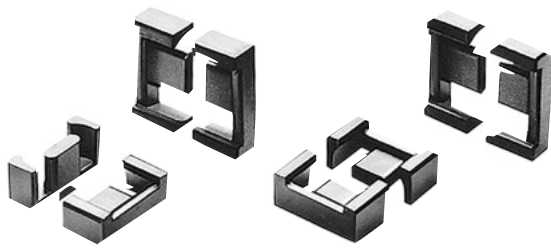

US. PAT. 4,760,366
 EP. PAT. 245,083(DE, FR, GB, NL)
 KS. UM 50,836
 TW. UM 39,406
 JP. PENDING

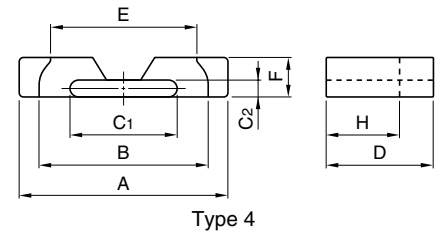
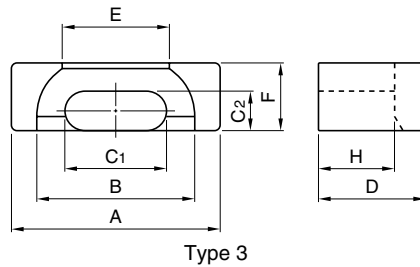
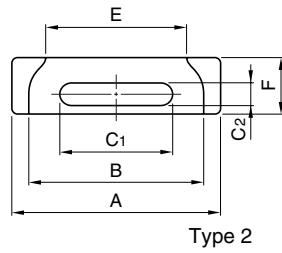
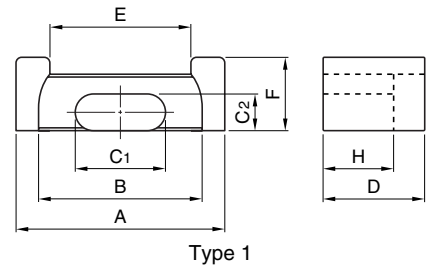

Part No.	Type	Dimensions in							
		mm		inches					
		A	B	C ₁	C ₂	D	E	F	H
		min.							
		min.							
PC44EPC10-Z	3	10.2±0.2	7.6	5.0±0.1	1.9±0.1	4.05±0.10	5.3	3.4±0.1	2.65±0.10
PC50EPC10-Z		.402±.008	.299	.197±.004	.075±.004	.159±.004	.209	.139±.004	.104±.004
PC44EPC13-Z	1	13.25±0.30	10.5	5.60±0.15	2.05±0.10	6.6±0.2	8.3	4.60±0.15	4.5±0.2
PC50EPC13-Z		.522±.012	.413	.220±.006	.081±.004	.026±.008	.327	.181±.006	.177±.008
PC44EPC17-Z	1	17.6±0.4	14.3	7.70±0.15	2.8±0.1	8.55±0.20	11.5	6.00±0.15	6.05±0.20
PC50EPC17-Z		.693±.016	.563	.303±.006	.110±.004	.337±.008	.453	.236±.006	.238±.008
PC44EPC19-Z	1	19.1±0.4	15.8	8.50±0.15	2.5±0.1	9.75±0.20	13.1	6.00±0.15	7.25±0.20
PC50EPC19-Z		.752±.016	.622	.335±.006	.098±.004	.384±.008	.516	.236±.006	.285±.008
PC44EPC25-Z	1	25.1±0.5	20.65	11.5±0.2	4.0±0.1	12.5±0.2	17.1	8.0±0.2	9.0±0.3
PC50EPC25-Z		.988±.020	.813	.453±.008	.157±.004	.492±.008	.673	.315±.008	.354±.012
PC44EPC25B-Z	2	25.1±0.5	20.4	13.8±0.2	2.50±0.15	11.4±0.15	16.5	6.5±0.2	8.75±0.15
PC50EPC25B-Z		.988±.020	.803	.543±.008	.098±.006	.449±.006	.650	.266±.008	.344±.006
PC44EPC27-Z	1	27.1±0.5	21.6	13.0±0.3	4.0±0.1	16.0±0.2	18.5	8.0±0.2	12.0±0.3
PC50EPC27-Z		1.067±.020	.850	.512±.012	.157±.004	.630±.008	.728	.315±.008	.472±.012
PC44EPC27N-Z	4	27.0±0.4	20.8	13.85±0.15	2.2±0.1	13.0±0.1	19.0	5.1±0.1	8.5±0.1
		1.063±.016	.819	.545±.006	.087±.004	.512±.004	.748	.201±.004	.335±.004
PC44EPC30-Z	1	30.1±0.5	23.6	15.0±0.3	4.0±0.1	17.5±0.2	20.0	8.0±0.2	13.0±0.3
PC50EPC30-Z		1.185±.020	.929	.591±.012	.157±.004	.689±.008	.787	.315±.008	.512±.012

Part No.	Effective parameter				Electrical characteristics			Wt (g)	Bobbin item
	C ₁ (mm ⁻¹)	A _e (mm ²)	∅ _e (mm)	V _e (mm ³)	AL-value (nH/N ²)*		Core loss (W) max. 100kHz, 200mT, 100°C		
				Without air gap		With air gap			
PC44EPC10-Z	1.89	9.39	17.8	167	1000±25%	40±7%	0.072	1.1	BEPC10-118GAFR
PC50EPC10-Z					660±25%	63±10%	0.025**		
PC44EPC13-Z	2.45	12.5	30.6	382	870±25%	40±4%	0.14	2.1	BEPC13-1110CPHFR BEPC13-1110GAFR
PC50EPC13-Z					560±25%	63±5%	0.039**		
PC44EPC17-Z	1.76	22.8	40.2	917	1150±25%	80±4%	0.35	4.5	BEPC17-1110CPHFR BEPC17-119GAFR
PC50EPC17-Z					740±25%	125±5%	0.1**		
PC44EPC19-Z	2.03	22.7	46.1	1050	940±25%	80±4%	0.4	5.3	BEPC19-1111CPHFR BEPC19-1110GAFR
PC50EPC19-Z					680±25%	125±5%	0.12**		
PC44EPC25-Z	1.28	46.4	59.2	2750	1560±25%	125±5%	1.11	13	BEPC25-1111CPHFR
PC50EPC25-Z					1080±25%	200±7%	0.32**		
PC44EPC25B-Z	1.39	33.3	46.2	1540	1560±25%	80±5%	0.65	11	BEPC25B-1111GAFR
PC50EPC25B-Z					1080±25%	125±7%	0.22**		
PC44EPC27-Z	1.34	54.6	73.1	4000	1540±25%	125±5%	1.56	18	BEPC27-1111CPHFR
PC50EPC27-Z					1030±25%	200±7%	0.46**		
PC44EPC27N-Z	1.70	33.0	55.9	1840	1400±25%	80±5% 125±7%	0.73	10	BEPC27N-1114CPHFR
PC44EPC30-Z	1.34	61.0	81.6	4980	1570±25%	125±5%	2.03	23	BEPC30-1112CPHFR
PC50EPC30-Z					1060±25%	200±7%	0.58**		

* AL-value: 1kHz, 0.5mA, 100Ts

** Core loss: 500kHz, 50mT, 100°C

EPC BOBBINS



Lead through type

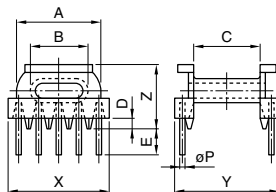

Drop in type

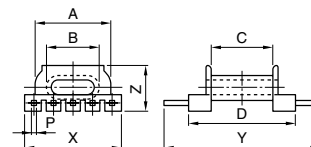

SMD type

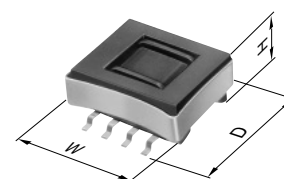
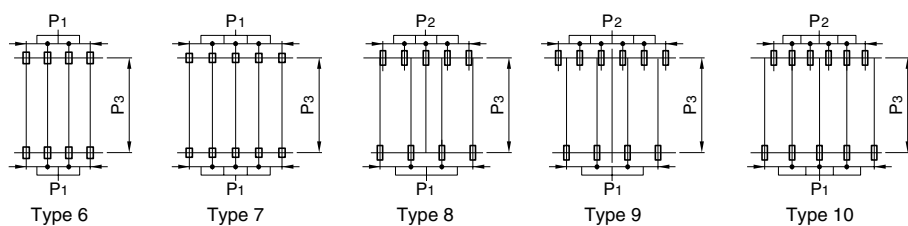
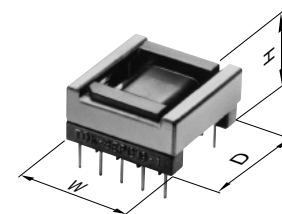
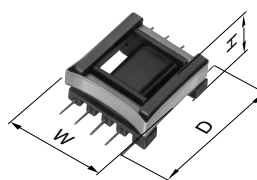
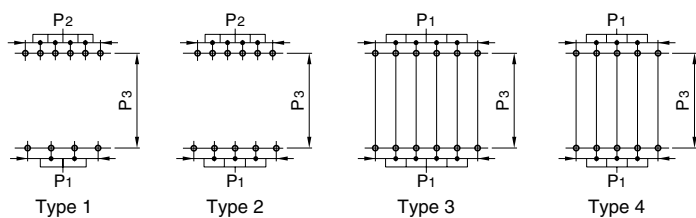
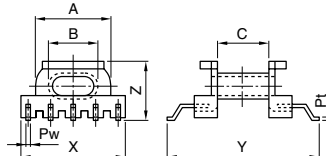

• All specifications are subject to change without notice.

EPC BOBBINS

Lead through type

Part No.	Dimensions in								
	mm inches								
	A	B	C	D	E	X	Y	Z	t*
BEPC13-1110CPHFR	10.22 .402	6.93 .273	6.88 .271	0.9 .035	2.5 .098	13.2 .520	13.2 .520	7.5 .295	0.5 .020
BEPC17-1110CPHFR	14.07 .554	9.88 .389	9.55 .376	2.5 .098	4.5 .177	17.2 .677	17.5 .689	11.9 .469	0.9 .035
BEPC19-1111CPHFR	15.57 .613	10.78 .424	11.95 .470	2.5 .098	4.5 .177	18.7 .736	19.0 .748	11.9 .469	0.9 .035
BEPC25-1111CPHFR	20.37 .802	13.73 .541	14.7 .579	3.0 .118	4.5 .177	25.0 .984	25.0 .984	16.0 .630	0.9 .035
BEPC27-1111CPHFR	21.32 .839	15.33 .604	20.7 .815	3.0 .118	4.5 .177	27.0 1.063	32.0 1.260	16.0 .630	0.8 .031
BEPC27N-1114CPHFR	20.5 .807	15.9 .623	16.5 .650	0.3 .012	3.5 .138	28.5 1.122	29.8 1.173	8.7 .343	0.9 .035
BEPC30-1112CPHFR	23.32 .918	17.33 .682	22.7 .894	3.0 .118	4.5 .177	30.0 1.181	35.0 1.378	16.0 .630	0.9 .035

Part No.	Dimensions in mm					Terminal pins	W D (mm) H	Parameter		Wt (g)	Connecting pin pattern
	øP (mm)	P ₁ (mm)	P ₂ (mm)	P ₃ (mm)	A _w (mm ²)			ℓ _w (mm)			
BEPC13-1110CPHFR	ø0.49	2.5	—	10.5	10	13.9 14.8 7.7	11.2	23.0	0.57	Type 4	
BEPC17-1110CPHFR	ø0.49	3.75	2.5	15.0	10	18.2 19.1 12.1	20.1	32.1	1.5	Type 1	
BEPC19-1111CPHFR	ø0.49	3.75	2.5	16.25	11	20.0 21.5 12.1	29.3	34.4	1.6	Type 2	
BEPC25-1111CPHFR	0.8	5.0	3.75	20.0	11	26.1 27.0 16.2	54.4	45.0	3.9	Type 2	
BEPC27-1111CPHFR	0.8	5.0	3.75	27.5	11	28.1 34.0 16.2	62.1	47.2	4.7	Type 2	
BEPC27N-1114CPHFR	0.8	3.75	—	25.0	14	29.0 36.5 9.0	32.4	43.7	3.1	Type 3	
BEPC30-1112CPHFR	1.0	5.0	—	30.0	12	31.1 37.0 16.2	68.1	51.1	6.0	Type 3	

UL Grade: 94V-0, Material: FR phenol, Pin material: Steel wire (Solder plated), Phosphor bronze (Solder plated) for BEPC25B-1111GAFR only. Maximum number of turns N that can be wound on bobbins, see section of "Maximum number of Turns on Bobbins".

* Minimum thickness of bobbin inside which core is placed, including flanges.

EPC BOBBINS

SMD type

Part No.	Dimensions in								
	mm inches								
	A	B	C	D	E	X	Y	Z	t*
BEPC10-118GAFR	7.5 .295	5.95 .234	3.9 .154	—	—	10.8 .425	11.5 .453	4.85 .193	0.35 .014
BEPC13-1110GAFR	10.3 .406	6.93 .273	6.9 .272	—	—	14.0 .551	20.4 .803	7.02 .276	0.5 .020
BEPC17-119GAFR	14.1 .555	9.9 .390	9.6 .378	—	—	17.5 .689	23.0 .906	9.8 .386	0.8 .031
BEPC19-1110GAFR	15.4 .606	10.7 .421	12.0 .472	—	—	20.0 .787	25.0 .984	9.75 .384	0.8 .031
BEPC25B-1111GAFR	20.1 .791	15.7 .618	14.7 .579	—	—	25.0 .984	28.7 1.130	9.8 .386	0.8 .031

Part No.	Dimensions in mm						Parameter		Wt (g)	Connecting pin pattern
	Pt×Pw (mm)	P ₁ (mm)	P ₂ (mm)	P ₃ (mm)	Terminal pins	W D (mm) H	Aw (mm ²)	ℓ w (mm)		
BEPC10-118GAFR	0.3×0.5	2.0	—	10.8	8	11.0 11.7 5.2	3.2	17.5	0.14	Type 6
BEPC13-1110GAFR	0.4×0.7	3.0	—	18.5	10	14.2 20.6 7.3	11.6	23.1	0.6	Type 7
BEPC17-119GAFR	0.4×0.7	5.0	3.5	21.8	9	18.2 23.2 9.9	20.1	32.1	1.1	Type 8
BEPC19-1110GAFR	0.4×0.7	5.0	3.5	23.8	10	20.2 25.2 9.9	28.2	34.4	1.3	Type 9
BEPC25B-1111GAFR	0.4×0.8	5.0	3.5	27.5	11	26.1 28.9 9.9	32.3	44.3	1.9	Type 10

UL Grade: 94V-0, Material: FR phenol, Pin material: Steel wire (Solder plated), Phosphor bronze (Solder plated) for BEPC25B-1111GAFR only.
Maximum number of turns N that can be wound on bobbins, see section of "Maximum number of Turns on Bobbins".

* Minimum thickness of bobbin inside which core is placed, including flanges.

Drop in type

Part No.	Dimensions in								
	mm inches								
	A	B	C	D	E	X	Y	Z	t*
BEPC19-1110SAFR	15.6 .611	10.7 .413	12.0 .480	18.6 .835	—	20.0 .768	26.0 1.228	9.55 .337	0.8 .031
BEPC25B-1111SFR	20.2 .795	16.0 .630	14.7 .579	21.7 .854	—	25.0 .984	37.7 1.484	9.40 .370	0.8 .031

Part No.	Dimensions in mm						Parameter		Wt (g)	Connecting pin pattern
	Pt×Pw (mm)	P ₁ (mm)	P ₂ (mm)	P ₃ (mm)	Terminal pins	W D (mm) H	Aw (mm ²)	ℓ w (mm)		
BEPC19-1110SAFR	0.4×0.7	5.0	3.5	24.0	10	20.2 26.2 9.8	28.2	34.4	1.3	Type 9
BEPC25B-1111SFR	0.49	5.0	3.5	34.7	11	26.0 37.9 9.5	30.9	50.5	2.1	Type 10

UL Grade: 94V-0, Material: FR phenol, Pin material: Steel wire (Solder plated), Phosphor bronze (Solder plated) for BEPC25B-1111GAFR only.
Maximum number of turns N that can be wound on bobbins, see section of "Maximum number of Turns on Bobbins".

* Minimum thickness of bobbin inside which core is placed, including flanges.

EPC ACCESSORIES

Part No.	Dimensions in		C	D	E	t	Material
	A	B					
FEPC-10-A	10.8 .425	2.8 .110	1.5 .059	8.0 .315	0.8 .031	0.2 .008	Stainless steel
FEPC-13-A	13.7 .541	2.8 .110	2.9 .114	14.75 .581	2.65 .104	0.25 .010	Stainless steel
FEPC-17-A	18.1 .713	3.8 .150	2.9 .114	19.1 .752	3.0 .118	0.3 .012	Stainless steel
FEPC-19-A	19.9 .783	3.8 .150	2.9 .114	21.5 .846	3.0 .118	0.3 .012	Stainless steel
FEPC-25-A	26.0 1.024	5.6 .220	2.9 .114	27.0 1.063	3.0 .118	0.3 .012	Stainless steel
FEPC-25B-A	26.0 1.024	5.0 .197	2.9 .114	24.5 .965	3.0 .118	0.3 .012	Stainless steel
FEPC-27-A	28.0 1.102	5.6 .220	2.9 .114	34.0 1.339	3.0 .118	0.3 .012	Stainless steel
FEPC-30-A	31.0 1.220	5.6 .220	2.9 .114	37.0 1.457	3.0 .118	0.3 .012	Stainless steel

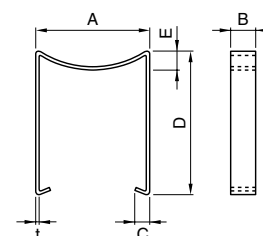

EP CORES

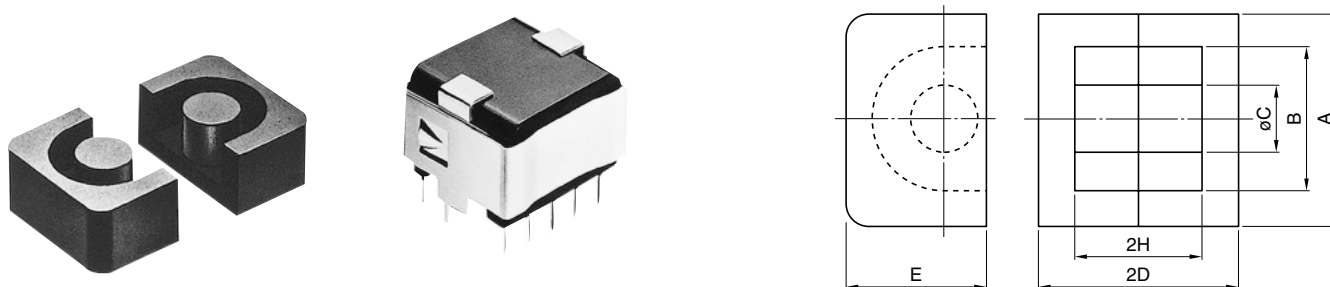

Part No.	Dimensions in							
	mm inches		A	B	øC	2D	E	2H
PC40EP7-Z	9.2±0.2 .362±.008	7.4±0.2 .291±.008	3.3±0.1 .130±.004	7.4±0.1 .291±.004	6.35±0.15 .250±.006	5.2±0.2 .205±.008		
PC40EP10-Z	11.5±0.3	9.4±0.2	3.3±0.15	10.2±0.2	7.65±0.2	7.4±0.2		
PC50EP10-Z	.453±.012	.370±.008	.130±.006	.402±.008	.301±.008	.291±.008		
PC40EP13-Z	12.5±0.3	10.0±0.3	4.35±0.15	12.85±0.15	8.8±0.2	9.2±0.2		
PC50EP13-Z	.492±.012	.394±.012	.171±.006	.506±.006	.346±.008	.362±.008		
PC40EP17-Z	18.0±0.4 .709±.016	12.0±0.4 .472±.016	5.68±0.18 .224±.007	16.8±0.2 .661±.008	11.0±0.25 .433±.010	11.3±0.3 .445±.012		
PC40EP20-Z	24.0±0.5 .945±.020	16.5±0.4 .650±.016	8.75±0.25 .344±.010	21.4±0.2 .843±.008	14.95±0.35 .589±.014	14.3±0.3 .563±.012		

Part No.	Effective parameter				Electrical characteristics			Wt (g)	Bobbin item
	C ₁ (mm ⁻¹)	A _e (mm ²)	l _e (mm)	V _e (mm ³)	A _L -value (nH/N ²)*		Core loss (W) max. 100kHz, 200mT, 100°C		
					Without air gap	With air gap			
PC40EP7-Z	1.52	10.3	15.7	162	830 min.	63±5% 100±7%	0.065	1.4	BEP7-316DFR
PC40EP10-Z	1.70	11.3	19.2	217	800 min.	63±5% 100±7%	0.08 0.02**	2.8	BEP10-318DFR
PC50EP10-Z					800±25%				
PC40EP13-Z	1.24	19.5	24.2	472	1170 min.	100±5% 160±7%	0.17 0.044**	5.1	BEP13-3110DFR
PC50EP13-Z					1100±25%				
PC40EP17-Z	0.84	33.9	28.5	966	1840 min.	100±5% 250±7%	0.33	12	BEP17-318DFR
PC40EP20-Z	0.508	78	39.8	3120	3200 min.	100±5% 250±7%	1.1	28	BEP20-8110DFR

* A_L-value: 1kHz, 0.5mA, 100Ts

** Core loss: 500kHz, 50mT, 100°C

EP BOBBINS

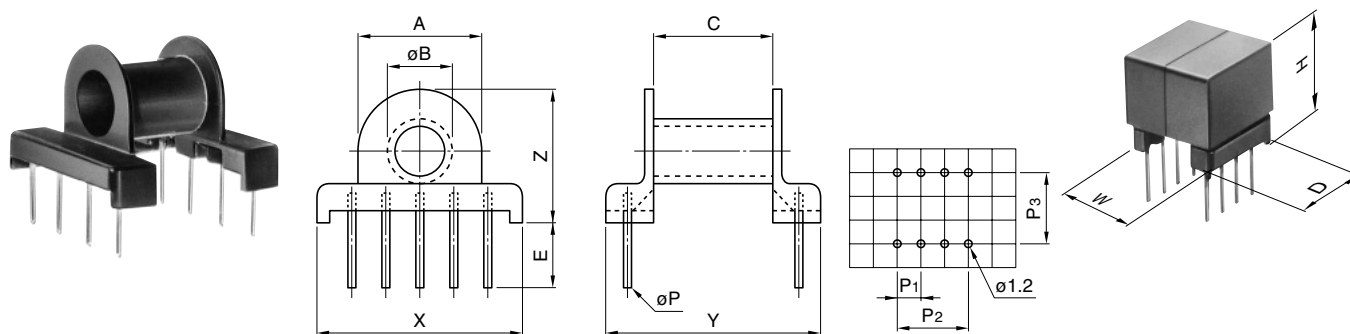

Part No.	Dimensions in		C	E	X	Y	Z	t*
	mm	inches						
	A	øB						
BEP7-316DFR	7.0 .276	4.5 .177	3.1 .122	3.0 .118	9.2 .362	7.4 .291	8.25 .325	0.25 .010
BEP10-318DFR	8.8 .346	4.8 .189	5.6 .220	5.2 .205	11.0 .433	11.0 .433	10.2 .402	0.40 .016
BEP13-3110DFR	9.6 .378	5.7 .224	7.7 .303	5.3 .209	13.2 .520	13.5 .531	10.75 .423	0.35 .014
BEP17-318DFR	11.4 .449	7.2 .283	9.4 .370	5.0 .197	19.0 .748	19.0 .748	13.2 .520	0.45 .018
BEP20-8110DFR	15.9 .626	10.2 .402	12.4 .488	5.0 .197	24.7 .972	21.5 .846	16.6 .654	0.325 .013

Part No.	Dimensions in mm				Terminal pins	W D (mm) H	Parameter		Wt (g)	Accessory item
	øP (mm)	P1 (mm)	P2 (mm)	P3 (mm)			Aw (mm ²)	ℓ w (mm)		
BEP7-316DFR	0.6	2.5	5.0	5.0	6	9.4 7.5 9.6	3.85	18.1	0.3	FEP-7-C
BEP10-318DFR	0.6	2.5	7.5	7.5	8	11.8 11.2 11.8	11.7	21.7	0.65	FEP-10-C
BEP13-3110DFR	0.6	2.5	10.0	10.0	10	13.4 13.7 12.7	16.6	23.9	0.74	FEP-13-C
BEP17-318DFR	0.6	5.0	15.0	15.0	8	19.25 19.25 15.7	19.0	29.1	1.3	FEP-17-C
BEP20-8110DFR	0.6	5.0	20.0	17.5	10	25.0 21.8 19.6	33.2	40.8	1.8	FEP-20-C

UL Grade: 94V-0, Material: FR phenol, Pin material: Phosphor bronze (Solder plated)

Maximum number of turns N that can be wound on bobbins, see section of "Maximum number of Turns on Bobbins".

* Minimum thickness of bobbin inside which core is placed, including flanges

RM SERIES

Cores

RM4 to RM14

Bobbins

BRM4 to BRM14

Accessories

FRM4 to FRM14



Ordering Code System

Cores

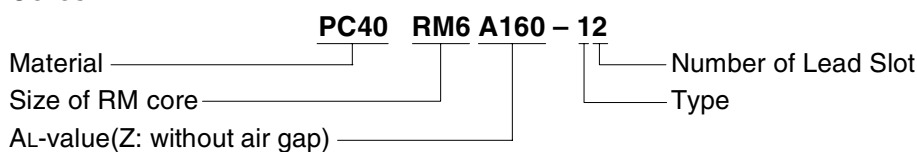

Bobbins

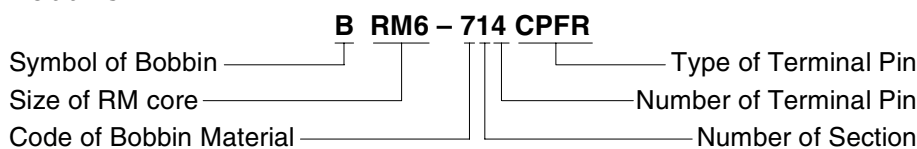

Accessories

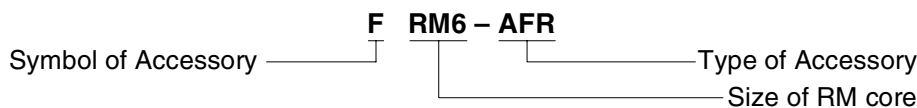

RM CORES

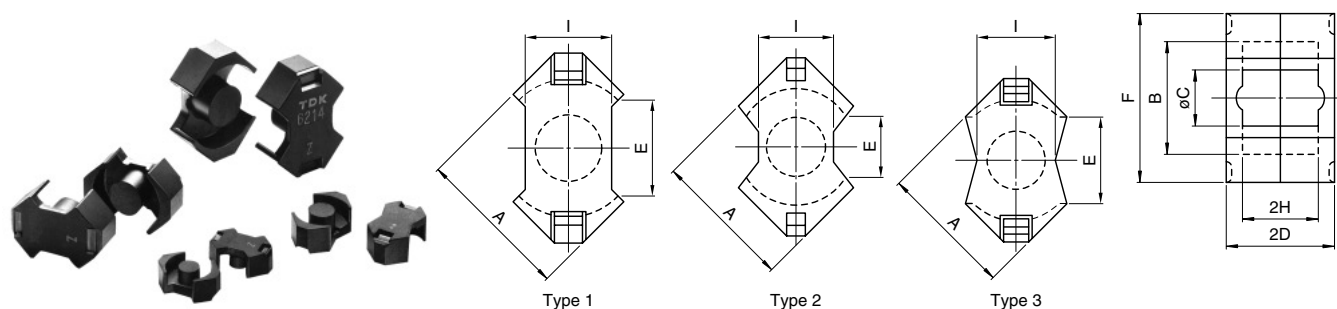

Part No.	Type	Dimensions in							
		A	B	øC	2D	E min.	F	2H	I
PC40RM4Z-12	1	9.63±0.18	8.15±0.2	3.8±0.1	10.4±0.1	5.8	10.8±0.2	7.2±0.2	4.45±0.15
PC50RM4Z-12		.379±.007	.321±.008	.150±.004	.409±.004	.228	.425±.008	.283±.008	.175±.006
PC40RM5Z-12	1	12.05±0.25	10.4±0.2	4.8±0.1	10.4±0.1	6.0	14.3±0.3	6.5±0.2	6.6±0.2
PC50RM5Z-12		.474±.010	.409±.008	.189±.004	.409±.004	.236	.563±.012	.256±.008	.260±.008
PC40RM6Z-12	3	14.4±0.3	12.65±0.25	6.3±0.1	12.4±0.1	8.4	17.6±0.3	8.2±0.2	8.0±0.2
PC50RM6Z-12		.567±.012	.498±.010	.248±.004	.488±.004	.331	.693±.012	.323±.008	.315±.008
PC40RM8Z-12	2	19.35±0.35	17.3±0.3	8.4±0.15	16.4±0.1	9.8	22.75±0.45	11.0±0.2	10.8±0.2
PC50RM8Z-12		.762±.014	.681±.012	.331±.006	.646±.004	.386	.896±.018	.433±.008	.425±.008
PC40RM10Z-12	2	24.15±0.55	21.65±0.45	10.7±0.2	18.6±0.1	11.3	27.85±0.65	12.7±0.3	13.25±0.25
PC50RM10Z-12		.951±.022	.852±.018	.421±.008	.732±.004	.445	1.096±.026	.500±.012	.522±.010
PC40RM12Z-12	2	29.25±0.55	25.5±0.5	12.6±0.2	23.5±0.1	12.9	36.75±0.65	17.1±0.3	16.0±0.3
PC50RM12Z-12		1.152±.022	1.004±.020	.496±.008	.925±.004	.508	1.447±.026	.673±.012	.630±.012
PC40RM14Z-12	1	34.2±0.5	29.5±0.5	14.75±0.25	28.8±0.2	17.0	41.6±0.6	21.1±0.3	18.7±0.3
PC50RM14Z-12		1.346±.020	1.161±.020	.581±.010	1.134±.008	.669	1.638±.024	.831±.012	.736±.012

Part No.	Effective parameter				Electrical characteristics			Wt (g)	Bobbin item
	C ₁ (mm ⁻¹)	A _e (mm ²)	l _e (mm)	V _e (mm ³)	AL-value (nH/N ²)*		Core loss (W) max. 100kHz, 200mT, 100°C		
					Without air gap	With air gap			
PC40RM4Z-12	1.62	14.0	22.7	318	680 min.	63±3%	0.12	1.7	BRM4-714SDFR
PC50RM4Z-12					960±25%	100±3% 160±3%			
PC40RM5Z-12	0.940	23.7	22.4	530	1250 min.	63±3%	0.18	3.0	BRM5-714CPFR
PC50RM5Z-12					1340±25%	100±3% 160±3%			
PC40RM6Z-12	0.781	36.6	28.6	1050	1830 min.	100±3%	0.41	5.5	BRM6-714CPFR
PC50RM6Z-12					1700±25%	160±3% 250±3%			
PC40RM8Z-12	0.594	64.0	38.0	2430	1950 min.	100±3% 160±3% 250±3%	0.97	13	BRM8-718CPFR
PC50RM8Z-12					3630 min.	160±3% 250±3% 400±3%			1.8
PC40RM10Z-12	0.450	98.0	44.0	4310	3630 min.	160±3% 250±3% 400±3%	3.3	42	
PC50RM10Z-12					4150 min.	160±3% 250±3% 400±3%			4.75
PC40RM12Z-12	0.406	140	56.9	7970	4150 min.	160±3% 250±3% 400±3%	7.0	70	
PC50RM12Z-12					4600 min.	160±3% 250±3% 400±3%			BRM12-7112CPFR
PC40RM14Z-12	0.393	178	70.0	12500	4600 min.	160±3% 250±3% 400±3%	7.0	70	BRM14-7110CPFR
PC50RM14Z-12					4600 min.	160±3% 250±3% 400±3%			BRM14-7112CPFR

* AL-value: 1kHz, 0.5mA, 100Ts

** Core loss: 500kHz, 50mT, 100°C

RM BOBBINS

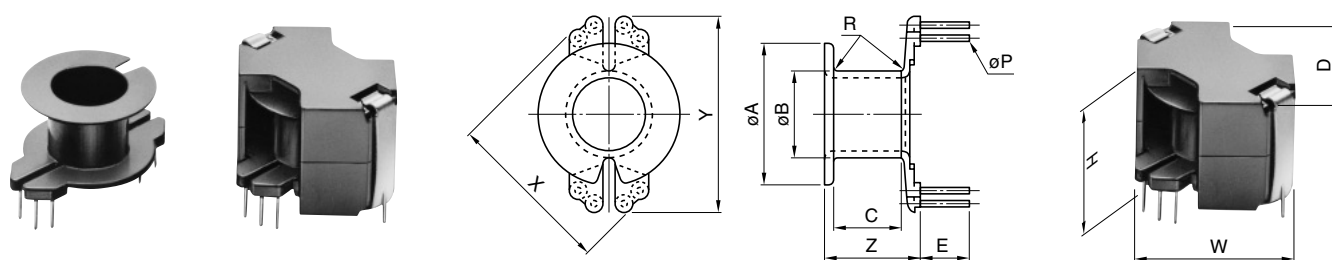

Part No.	Dimensions in		C	E	X	Y	Z	t*
	mm	inches						
BRM4-716SDFR	7.7 .303	4.9 .193	5.9 .232	5.25 .207	10.0 .394	4.3 .169	8.0 .315	0.25 .010
BRM5-716CPFR	10.1 .398	5.95 .234	4.9 .193	5.0 .197	12.5 .492	16.2 .638	7.9 .311	0.35 .014
BRM6-716CPFR	12.3 .484	7.45 .293	6.4 .252	4.5 .177	15.0 .591	20.0 .787	9.6 .378	0.3 .012
BRM8-718CPFR	16.9 .665	9.95 .392	9.15 .360	5.6 .220	20.0 .787	24.6 .967	12.7 .500	0.425 .017
BRM10-7112SDFR	21.0 .827	12.5 .492	10.75 .423	4.78 .118	22.5 .886	28.0 1.102	13.5 .531	0.5 .020
BRM12-7112CPFR	24.7 .972	14.5 .571	14.8 .583	6.35 .250	30.0 1.181	38.0 1.496	18.9 .744	0.55 .022
BRM14-7112CPFR	28.8 1.134	16.8 .661	18.8 .740	6.35 .250	35.6 1.402	41.9 1.650	22.9 .902	0.6 .024

Part No.	Dimensions in mm			Parameter		Wt (g)	Other bobbins' item	Accessory item
	øP (mm)	Terminal pins	W D (mm) H	Aw (mm ²)	∅ w (mm)			
BRM4-716SDFR	∅0.45	4	10.0 10.0 10.5	8.05	19.8	0.23	BRM4-714SDFR	FRM4-AFR
BRM5-716CPFR	0.5	6	12.5 12.5 10.5	10.1	25	0.26	BRM5-714CPFR	FRM5-AFR
BRM6-716CPFR	0.6	6	15.0 15.0 12.5	15.5	31	0.43	BRM6-714CPFR	FRM6-AFR
BRM8-718CPFR	0.6	8	20.0 20.0 16.5	31.0	42	1.00	BRM8-7112CPFR	FRM8-AFR
BRM10-7112SDFR	∅0.51	12	24.7 24.7 18.7	45.7	53	1.6	BRM10-7110SDNFR	FRM10-AFR
BRM12-7112CPFR	0.8	12	30.0 30.0 23.6	75.5	55	2.7	BRM12-7111CPFR	FRM12-AFR
BRM14-7112CPFR	0.83	12	35.6 35.6 29.0	113	72	3.8	BRM14-7110CPFR	FRM14-AFR

UL Grade: 94V-0, Material: FR phenol, Pin material: Steel wire (Solder plated)

Maximum number of turns N that can be wound on bobbins, see section of "Maximum number of Turns on Bobbins".

* Minimum thickness of bobbin inside which core is placed, including flanges.

Connecting Pin Patterns (2.54mm/0.1 inch grids) View in mounting direction

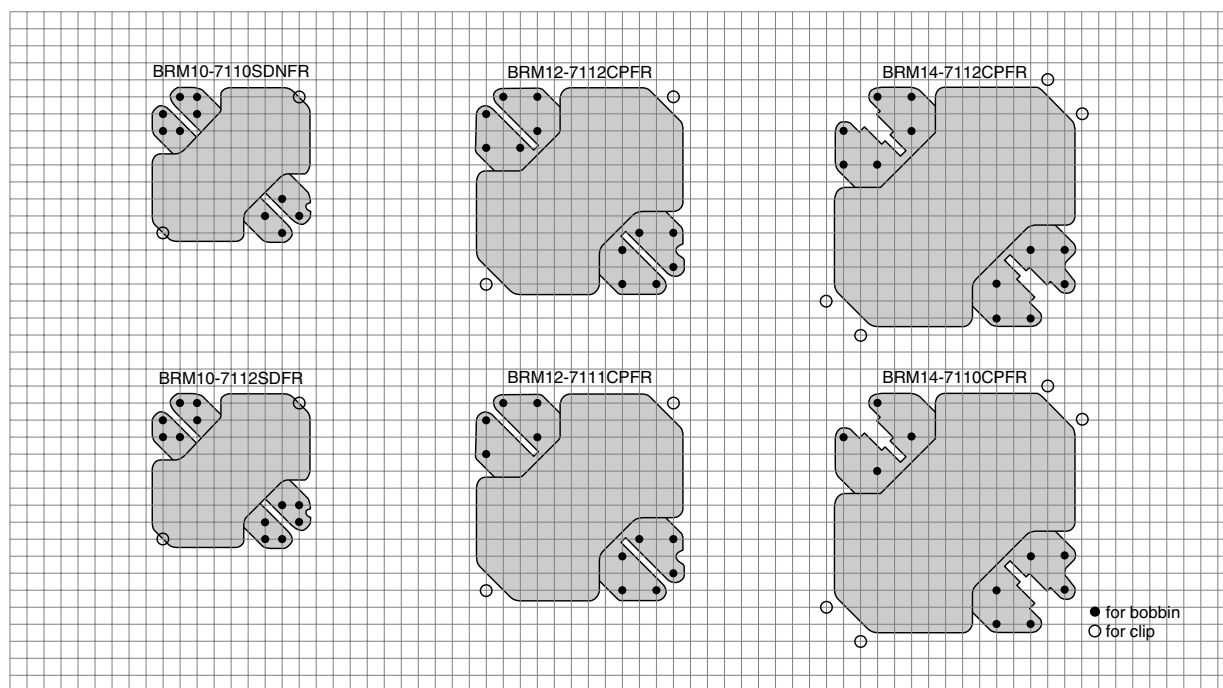
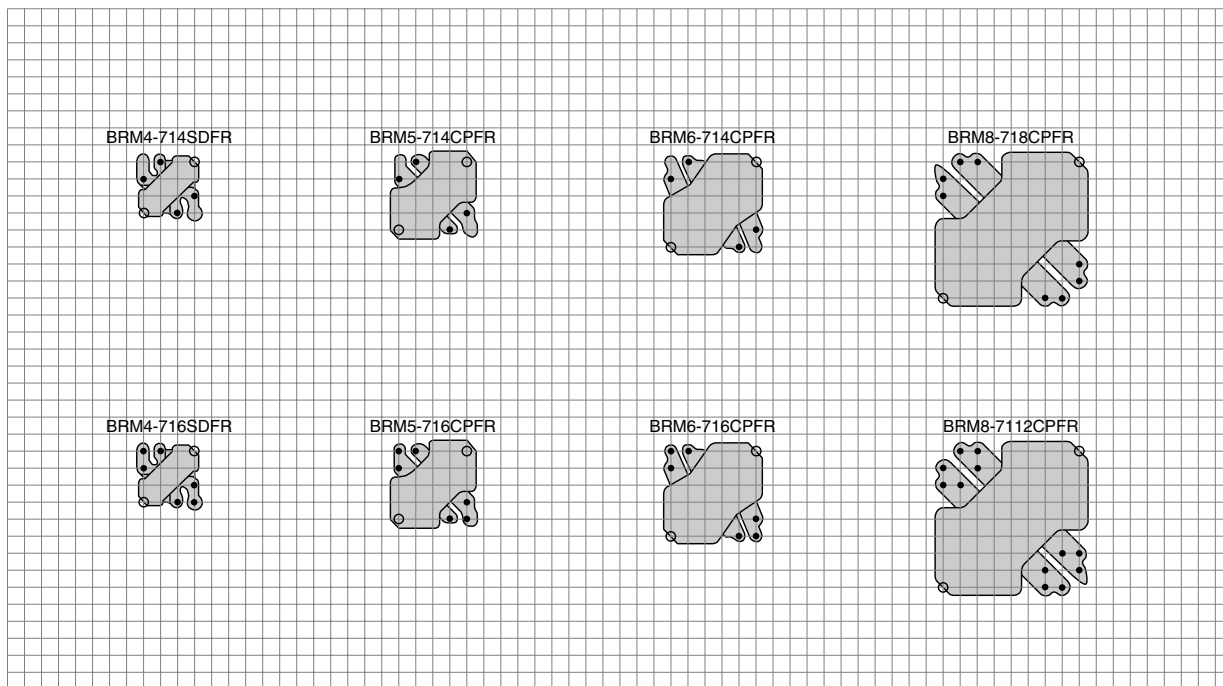

SMD CORES

Cores

- EE5, EE8.9/8
- ER9.5/5, ER11/3.9, ER11/5
- ER14.5/6
- EEM12.7/13.7

Bobbins

- BE5, BE8.9/8
- BER9.5/5, BER11/3.9, BER11/5
- BER14.5/6
- BEM12.7

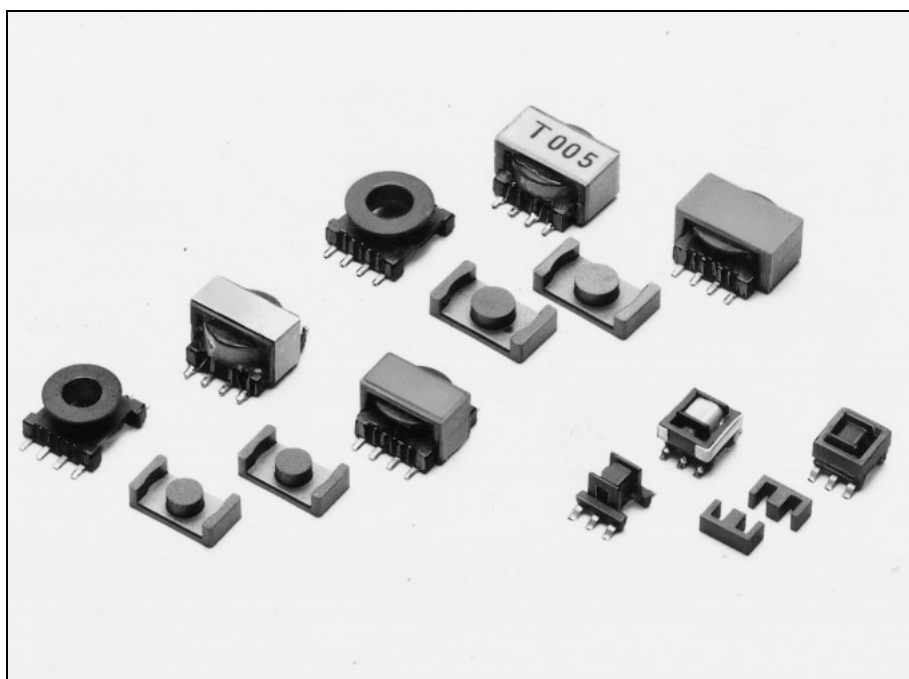

Ordering Code System

Cores

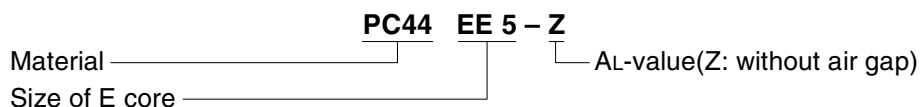

Bobbins

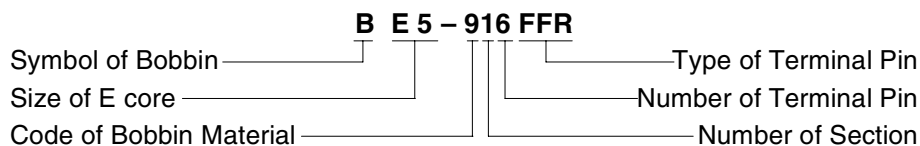

• All specifications are subject to change without notice.

EE, ER AND EEM CORES

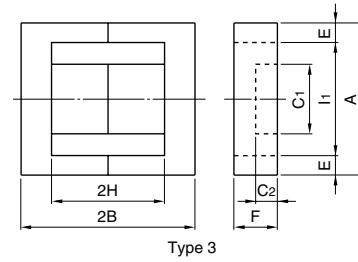
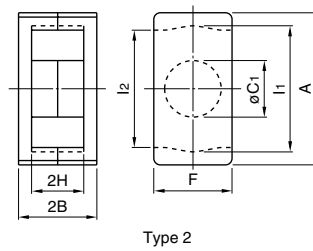
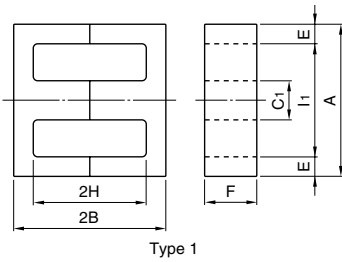
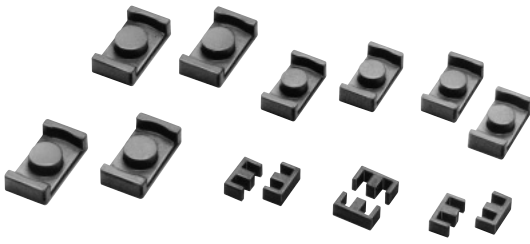

Part No.	Type	Dimensions in								
		mm inches								
		A	2B	C1	C2	E	F	2H	l1	l2
PC44EE5-Z	1	5.25±0.05 .207±.002	5.3±0.1 .209±.004	1.35±0.05 .053±.002		0.70±0.05 .028±.002	1.95±0.05 .077±.002	4.0 .157	3.85 .152	
PC44EE8.9/8-Z	1	8.86±0.20 .349±.008	8.0±0.3 .315±.012	1.90±0.12 .075±.005		1.91±0.20 .075±.008	1.90±0.12 .075±.008	4.5±0.3 .177±.012	5.08 min. .200 min.	
PC44ER9.5/5-Z PC50ER9.5/5-Z	2	9.35±0.15 .368±.006	4.9±0.1 .193±.004	3.4±0.1 .134±.004			4.9±0.1 .193±.004	3.35±0.15 .132±.004	7.63±0.13 .300±.005	7.0 min. .276 min.
PC44ER11/3.9-Z PC50ER11/3.9-Z	2	10.83±0.18 .426±.007	3.85±0.10 .152±.004	4.13±0.13 .163±.005			5.9±0.1 .232±.004	2.10±0.15 .083±.006	8.85±0.15 .348±.006	7.9 min. .311 min.
PC44ER11/5-Z PC50ER11/5-Z	2	10.83±0.18 .426±.007	4.9±0.1 .193±.004	4.13±0.13 .163±.005			5.9±0.1 .232±.004	3.15±0.15 .124±.006	8.85±0.15 .348±.006	7.9 min. .311 min.
PC44ER14.5/6-Z PC50ER14.5/6-Z	2	14.5±0.2 .571±.008	5.9±0.1 .232±.004	4.7±0.1 .185±.004			6.7±0.1 .264±.004	3.3±0.2 .130±.008	11.8±0.2 .465±.008	11.8±0.2 .465±.008
PC44EEM12.7/13.7-Z PC50EEM12.7/13.7-Z	3	12.75±0.25 .502±.010	13.7±0.3 .539±.012	6.0±0.1 .236±.004	1.85±0.10 .073±.004	1.7±0.1 .067±.004	3.30±0.15 .130±.006	9.1±0.3 .358±.012	9.0 min. .354 min.	

Part No.	Effective parameter				Electrical characteristics		Wt (g)	Bobbin item
	C1 (mm ⁻¹)	Ae (mm ²)	ℓe (mm)	Ve (mm ³)	AL-value (nH/N ²) [*] Without air gap	With air gap		
PC44EE5-Z	4.72	2.67	12.6	33.6	200 min.		0.2	BE5-916FFR
PC44EE8.9/8-Z	3.15	4.96	15.6	77.4	480±25%		0.6	BE8.9/8-118GFR
PC44ER9.5/5-Z PC50ER9.5/5-Z	1.68	8.47	14.2	120	610 min. 750±25%	63±5% 100±7%	0.6	BER9.5/5-118GAFR
PC44ER11/3.9-Z PC50ER11/3.9-Z	1.08	11.7	12.6	147	1040 min. 1100±25%	63±5% 100±7%	0.8	BER11/3.9-1110GAFR
PC44ER11/5-Z PC50ER11/5-Z	1.24	11.9	14.7	175	870 min. 960±25%	63±5% 100±7%	1.0	BER11/5-1110GAFR
PC44ER14.5/6-Z PC50ER14.5/6-Z	1.08	17.6	19.0	334	1280 min. 1150±25%	100±5% 160±7%	1.8	BER14.5/6-1110GAFR
PC44EEM12.7/13.7-Z PC50EEM12.7/13.7-Z	2.28	12.0	27.3	328	820±25% 580±25%	40±5% 63±7%	1.9	BEM12.7-118GAFR

* AL-value: 1kHz, 0.5mA, 100Ts

EE, ER AND EEM BOBBINS

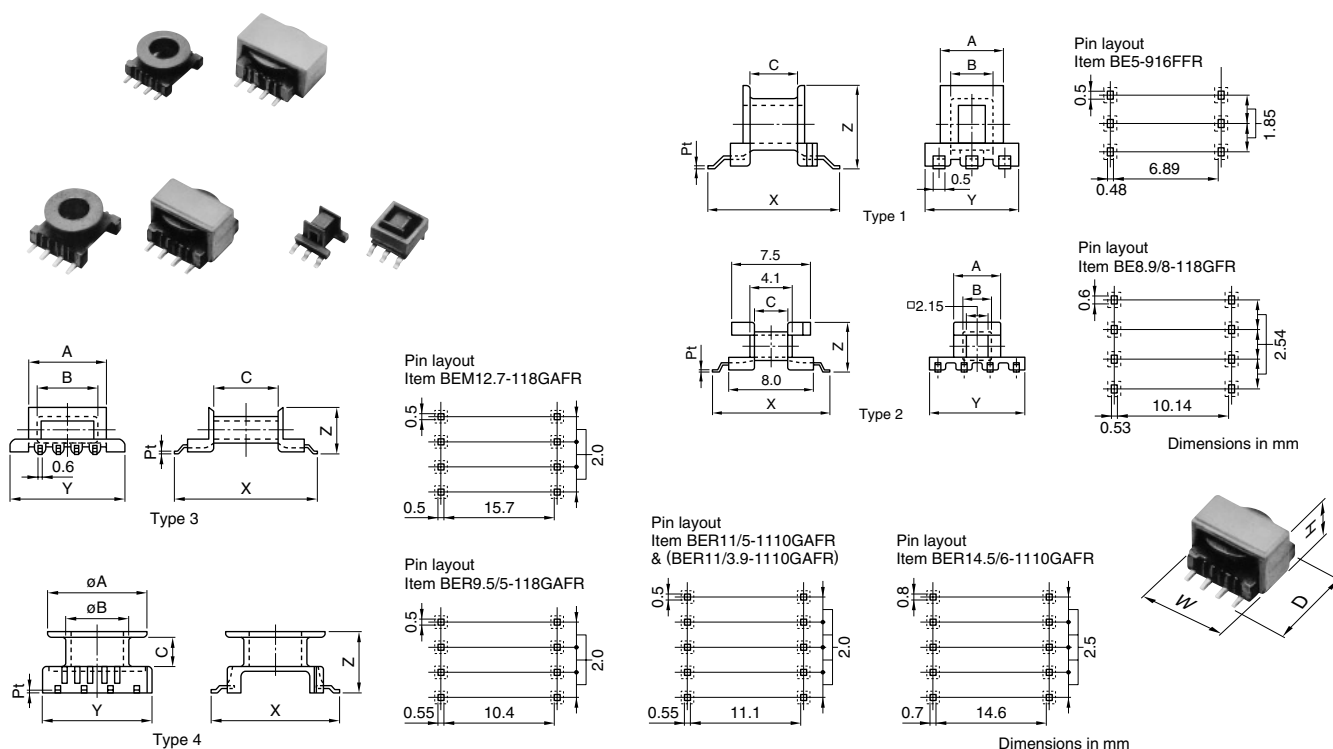

Part No.	Type	Dimensions in mm							t*
		A	B	C	X	Y	Z		
BE5-916FFR BE5-926F1FR	1	3.5 .138	2.3 .091	2.7 .106	7.85 .309	5.2 .205	4.65 .183	0.4 .016	
BE8.9/8-118GFR	2	4.5 .177	2.7 .106	3.1 .122	11.2 .441	9.2 .362	4.75 .187	0.2 .008	
BEM12.7-118GAFR	3	8.9 .350	6.9 .272	7.5 .295	16.7 .657	12.8 .504	4.9 .193	0.35 .014	
BER9.5/5-118GAFR	4	7.3 .287	4.45 .175	2.15 .085	11.5 .452	8.6 .339	4.45 .175	0.4 .016	
BER11/3.9-1110GAFR	4	8.5 .335	5.2 .205	1.05 .041	12.45 .490	10.5 .413	3.4 .134	0.4 .016	
BER11/5-1110GAFR**	4	8.5 .335	5.2 .205	1.95 .077	12.2 .480	10.5 .413	4.70 .185	0.4 .016	
BER14.5/6-1110GAFR	4	11.4 .449	5.9 .232	2.0 .079	16.0 .630	14.0 .551	5.75 .226	0.4 .016	

Part No.	Dimensions in mm			Parameter		Material	Wt (g)	Accessory item
	Pt×Pw (mm)	Terminal pins	w D (mm) H	Aw (mm ²)	∅ w (mm)			
BE5-916FFR BE5-926F1FR	0.2×0.5	6	5.7 7.8 4.8	1.62	12.4	Diallyl Phtalate	0.03 0.07	FE-5-A
BE8.9/8-118GFR	0.2×0.6	6	9.3 11.3 4.8	2.79	14.4	FR Phenol	0.17	—
BEM12.7-118GAFR	0.3×0.5	8	13.6 16.8 5.0	7.5	22.4	FR Phenol	0.31	FEM12.7/13.7-A
BER9.5/5-118GAFR	0.3×0.5	8	9.9 11.7 5.9	3.06	18.5	FR Phenol	0.16	FER9.5/5-A
BER11/3.9-1110GAFR	0.25×0.7	10	11.0 12.6 4.7	1.73	21.5	FR Phenol	0.21	FER11/3.9-A
BER11/5-1110GAFR**	0.3×0.5	10	11.5 12.3 6.4	3.22	21.5	FR Phenol	0.21	FER11/5-A
BER14.5/6-1110GAFR	0.3×0.8	10	15.1 16.2 7.3	5.5	27.2	FR Phenol	0.55	FER14.5/6-A

UL Grade: 94V-0, Material of pins: F, G types are Phosphor bronze wire (Solder plated), GA type is Steel wire (Solder plated). Maximum number of turns N that can be wound on bobbins, see section of "Maximum number of Turns on Bobbins".

* Minimum thickness of bobbin.

** 8-pin is available (Part No. BER11/5-118GAFR).

ET, UU AND FT SERIES

Cores

ET20 to 35

UU10.1 to UU19.7B

FT20.6

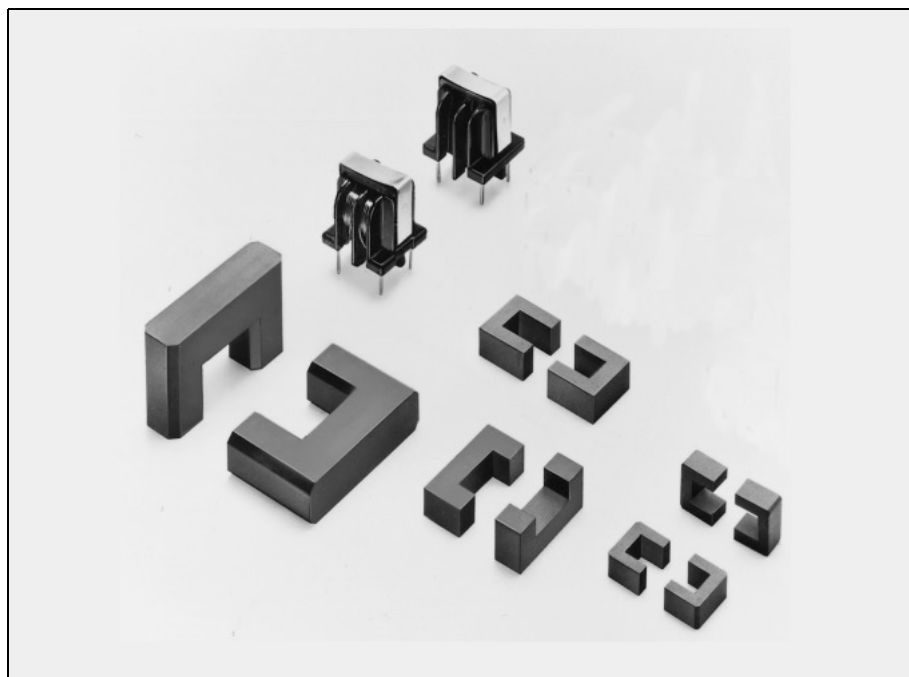

Ordering Code System

Cores

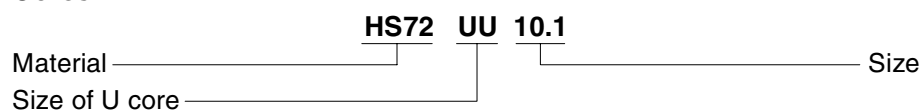

ET AND UU CORES

ET Cores

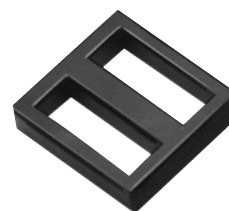
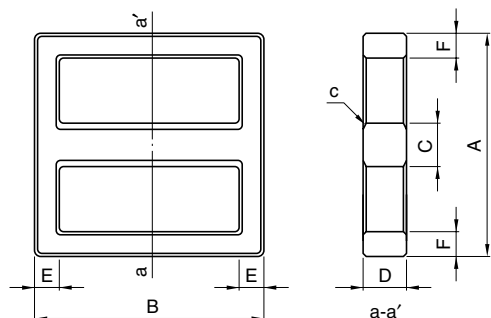

Part No.	AL-value* (nH/N ²)	Dimensions in						Ae (mm ²)	ℓe (mm)
		mm inches							
		A	B	C	D	E	F		
HS72ET20	3100 ^{+40%} -25%	20.1±0.4 .791±.016	20.1±0.4 .791±.016	4.0±0.2 .157±.008	4.4±0.2 .173±.008	2.00±0.15 .079±.006	2.00±0.15 .079±.006	17.6	50.6
HS72ET24	2600 ^{+40%} -25%	24.2±0.5 .953±.020	24.2±0.5 .953±.020	4.0±0.2 .157±.008	4.0±0.3 .157±.012	2.40±0.15 .094±.006	2.40±0.15 .094±.006	17.8	61.0
HS72ET28	3550 ^{+40%} -25%	28.45±0.55 1.120±.022	28.45±0.55 1.120±.022	5.0±0.2 .197±.008	5.0±0.3 .197±.012	2.90±0.15 .114±.006	2.90±0.15 .114±.006	27.4	71.4
HS10ET28	4835±30%	28.45±0.55 1.120±.022	28.45±0.55 1.120±.022	5.0±0.2 .197±.008	5.0±0.3 .197±.012	2.90±0.15 .114±.006	2.90±0.15 .114±.006	27.4	71.4
HS72ET35	6000 ^{+40%} -25%	35.3±0.6 1.390±.024	35.3±0.6 1.390±.024	7.5±0.3 .295±.012	7.5±0.3 .295±.012	4.0±0.2 .157±.008	4.0±0.2 .157±.008	58.6	86.7

* AL-value: 1kHz, 0.25A/m, 10Ts

UU Cores

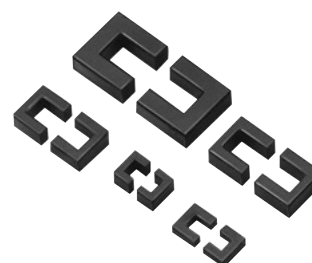
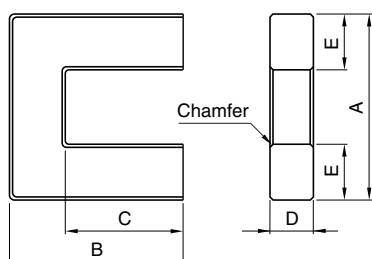

Part No.	AL-value* (nH/N ²)	Dimensions in					Ae (mm ²)	ℓe (mm)
		mm inches						
		A	B	C	D	E		
HS72UU10.1	1005±25%	10.1±0.3 .398±.012	7.5±0.25 .295±.010	4.5±0.25 .177±.010	2.9±0.15 .114±.006	2.95±0.15 .116±.006	8.6	35.7
HS72UU10.5	1500±25%	10.5±0.3 .413±.012	7.80±0.2 .307±.008	5.25±0.3 .207±.012	5.00±0.20 .197±.008	2.5±0.20 .098±.008	12.5	40.3
HS72UU15.7	2600±25%	15.7±0.4 .618±.016	9.70±0.25 .382±.010	6.00±0.30 .236±.012	6.00±0.30 .236±.012	4.50 .177	24.8	50.0
HS72UU19.7B	2650±25%	19.7±0.4 .776±.016	17.7±0.3 .697±.012	11.7±0.3 .461±.012	6.00±0.30 .236±.012	6.00±0.30 .236±.012	35.7	81.1

* AL-value: 1kHz, 0.25A/m, 10Ts

FT CORES

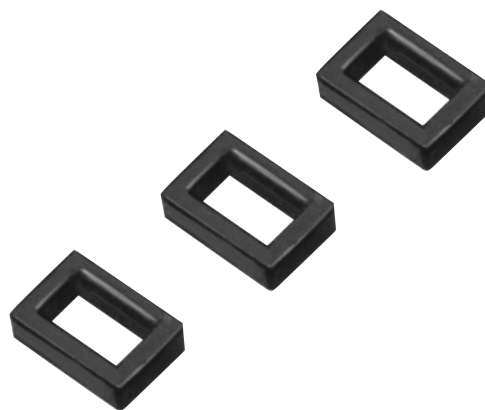
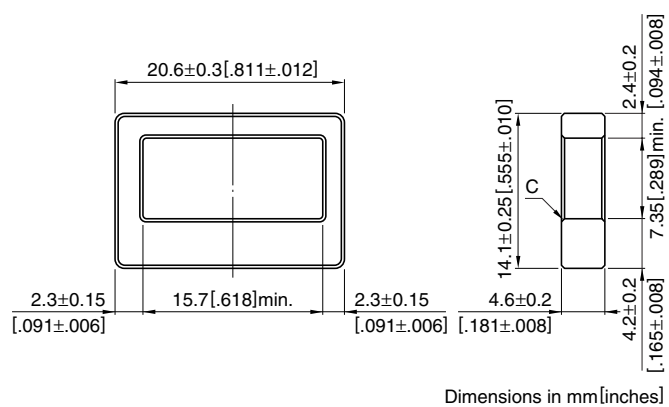

Part No.	AL-value* (nH/N ²)	Ae (mm ²)	∅ e (mm)
HS72FT20.6	2200 ^{+40%} _{-30%}	12.1	52.9
HS10FT20.6	2690 ± 30%	12.1	52.9

* AL-value: 1kHz, 0.25A/m, 10Ts

TOROIDAL CORES

TDK's toroidal cores are available in a number of sizes. Therefore, by selecting the ferrite material which corresponds to the application, it is possible to design stable transformers, inductors, etc. to cover a wide band range.

FEATURES

- Selection of core material to correspond to the application is possible as a result of standard ferrite materials with $\mu_i=5500$ to 10000.
- Epoxy and paraxyllylene insulation coating is available.

APPLICATIONS

Choke coils, filters, current sensors, EMI/RFI filters, balun transformers.

T14 to T44.5

Material: HS52, HS72, HS10

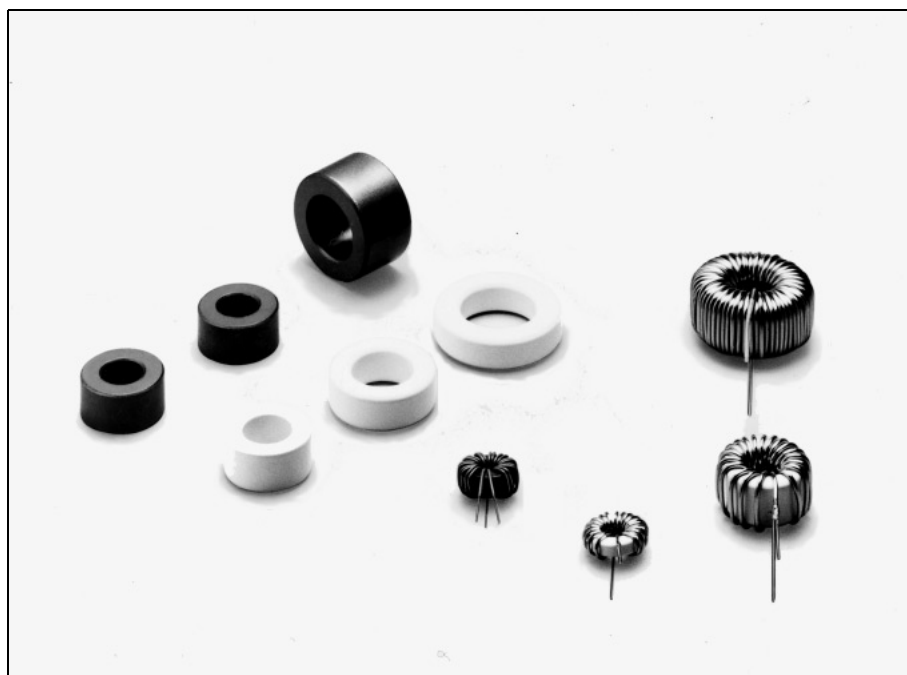

Ordering Code System

Cores

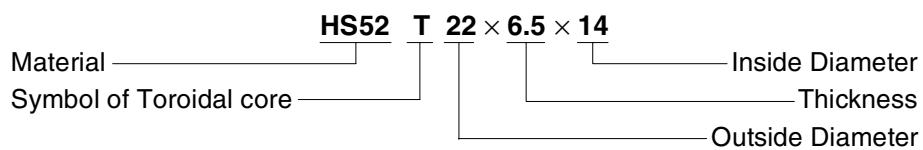

T CORES

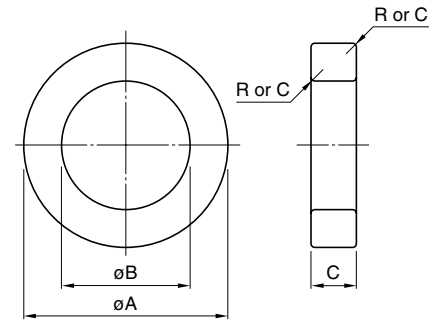

Part No.	JIS C 2569	Dimensions in			Effective parameter	
		ϕA	ϕB	C	C_1 (mm ⁻¹)	A_e (mm ²)
T14×7×8		14.0±0.3 .551±.012	8.0±0.3 .315±.012	7.0±0.3 .276±.012	1.60	20.5
T18×10×10	FOR-18-10-10	18.0±0.3 .709±.012	10.0±0.3 .394±.012	10.0±0.3 .394±.012	1.07	38.9
T16×8×12		16.0±0.3 .630±.012	12.0±0.3 .472±.012	8.0±0.3 .315±.012	2.73	15.9
T20×10×12	FOR-20-10-12	20.0±0.4 .787±.016	12.0±0.4 .472±.016	10.0±0.3 .394±.012	1.23	39.1
T22×6.5×14		22.0±0.4 .866±.016	14.0±0.4 .551±.016	6.5±0.3 .256±.012	2.14	25.6
T25×13×15		25.0±0.4 .984±.016	15.0±0.4 .591±.016	13.0±0.3 .512±.012	0.946	63.6
T28×13×16	FOR-28-13-16	28.0±0.4 1.102±.016	16.0±0.4 .630±.016	13.0±0.3 .512±.012	0.864	76.0
T31×8×19		31.0±0.5 1.220±.020	19.0±0.5 .748±.020	8.0±0.3 .315±.012	1.60	47.1
T38×14×22		38.0±0.5 1.496±.020	22.0±0.5 .866±.020	14.0±0.4 .551±.016	0.821	109
T44.5×13×30	FOR-45-13-30	44.5±0.5 1.752±.020	30.0±0.5 1.181±.020	13.0±0.4 .512±.016	1.23	93

Part No.	Effective parameter			AL-value (nH/N ²)			Wt (g)
	ϕe (mm)	V_e (mm ³)	R or C	Material			
				HS52*	HS72**	HS10***	
T14×7×8	32.8	671	C0.5	3800±25%	5100±25%	6800±30%	3.4
T18×10×10	41.5	1610	C0.5	6400±25%	8800±25%	10150±30%	8.3
T16×8×12	43.4	689	C1.0	2500±25%	3400±25%	4500±30%	3.4
T20×10×12	48.1	1880	C0.5	5600±25%	7600±25%	10000±30%	9.5
T22×6.5×14	54.7	1400	C0.5	3200±25%	4400±25%	5750±30%	6.9
T25×13×15	60.2	3830	C1.0	7300±25%	9900±25%	13000±30%	19
T28×13×16	65.6	4990	C0.5	8000±25%	10700±25%	14200±30%	26
T31×8×19	75.5	3550	C1.0	4300±25%	5800±25%	7700±30%	17
T38×14×22	89.7	9800	C1.0	8400±25%	10700±25%	—	50
T44.5×13×30	114	10600	C0.5	5600±25%	7100±25%	—	53

* AL-value: 100kHz, 100mV, 10Ts

** AL-value: 100kHz, 10mV, 5Ts

*** AL-value: 10kHz, 10mV, 10Ts

Can be coated with epoxy. If epoxy-coated products are desired, please suffix E to part No. when ordering.

Ex. HS52 T22 × 6.5 × 12E

Outer diameter(ϕA)

10mm min.(T10): Epoxy coating

8mm max.(T8): Paraxylolene coating

* Dielectric breakdown voltage 1000Vd.c. min.

• All specifications are subject to change without notice.