

iW3620 Product Brief

Digital PWM Constant Current Controller for AC/DC LED Driver

iWatt

1.0 Features

- Primary-side feedback eliminates opto-isolators and simplifies design
- Quasi-resonant operation for highest overall efficiency
- **EZ-EMI**® design to easily meet global EMI standards
- Up to 130 kHz switching frequency enables small adapter size
- Very tight LED constant current regulation
- No external compensation components required
- Built-in output constant-current control with primary-side feedback for LED driver.
- Low start-up current (10 μ A typical)
- Built-in soft start
- Built-in short circuit protection and output overvoltage protection
- Current sense resistor short protection
- Overtemperature Protection
- Open circuit protection
- Universal input range from 85 V_{ac} to 264 V_{ac}
- Single-fault protection
- Small input bulk capacitor
- Long MTBF
- High efficiency

2.0 Description

The iW3620 is a high performance AC/DC offline LED driver which uses digital control technology to build peak current mode PWM flyback power supplies. The device operates in quasi-resonant mode at heavy load to provide high efficiency along with a number of key built-in protection features while minimizing the external component count, simplifying EMI design and lowering the total bill of material cost. The iW3620 removes the need for secondary feedback circuitry while achieving excellent line and load regulation. It also eliminates the need for loop compensation components while maintaining stability over all operating conditions. Pulse-by-pulse waveform analysis allows for a loop response that is much faster than traditional solutions, resulting in improved dynamic load response. The built-in current limit function enables optimized transformer design in universal off-line applications over a wide input voltage range.

3.0 Applications

- LED lighting

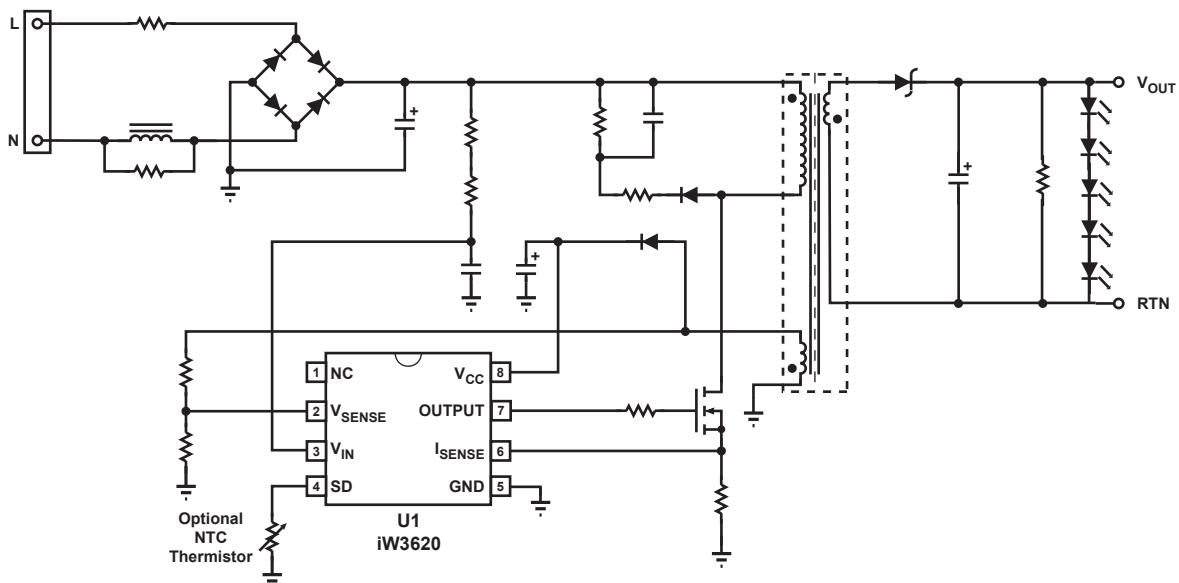

Figure 3.1 : Typical Application Circuit

iW3620 Product Brief

Digital PWM Constant Current Controller for AC/DC LED Driver

iWatt

4.0 Pinout Description

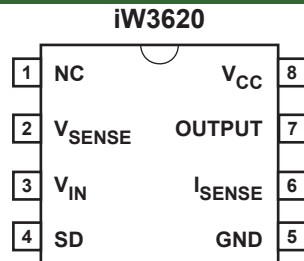

Pin #	Name	Type	Pin Description
1	NC	-	No connection.
2	V _{SENSE}	Analog Input	Auxiliary voltage sense (used for primary side regulation).
3	V _{IN}	Analog Input	Rectified AC line average voltage sense.
4	SD	Analog Input	External shutdown control. Connect to ground through a resistor if not used.
5	GND	Ground	Ground.
6	I _{SENSE}	Analog Input	Primary current sense (used for cycle-by-cycle peak current control and limit).
7	OUTPUT	Output	Gate drive for external MOSFET switch.
8	V _{CC}	Power Input	Power supply for control logic and voltage sense for power-on reset circuitry.

5.0 Absolute Maximum Ratings

Absolute maximum ratings are the parameter values or ranges which can cause permanent damage if exceeded. For maximum safe operating conditions, refer to Electrical Characteristics in Section 6.0.

Parameter	Symbol	Value	Units
DC supply voltage range (pin 8, I _{CC} = 20mA max)	V _{CC}	-0.3 to 18	V
DC supply current at V _{CC} pin	I _{CC}	20	mA
Output (pin 7)		-0.3 to 18	V
V _{SENSE} input (pin 2, I _{Vsense} ≤ 10 mA)		-0.7 to 4.0	V
V _{IN} input (pin 3)		-0.3 to 18	V
I _{SENSE} input (pin 6)		-0.3 to 4.0	V
SD input (pin 4)		-0.3 to 18	V
Power dissipation at T _A ≤ 25°C	P _D	526	mW
Maximum junction temperature	T _{J MAX}	125	°C
Storage temperature	T _{STG}	-65 to 150	°C
Lead temperature during IR reflow for ≤ 15 seconds	T _{LEAD}	260	°C
Thermal Resistance Junction-to-Ambient	θ _{JA}	160	°C/W
ESD rating per JEDEC JESD22-A114		2,000	V
Latch-Up test per JEDEC 78		±100	mA

iW3620 Product Brief

Digital PWM Constant Current Controller for AC/DC LED Driver



6.0 Physical Dimensions

8-Lead Small Outline (SOIC) Package

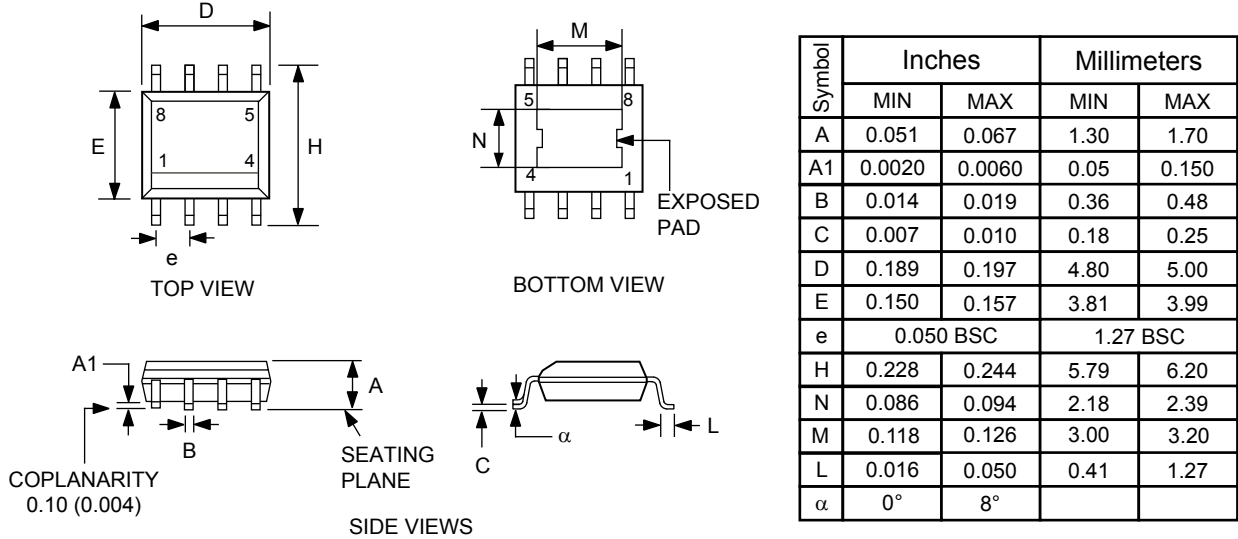

Figure 6.1 : Physical dimensions, 8-lead SOIC package

Compliant to JEDEC Standard MS12F

Controlling dimensions are in inches; millimeter dimensions are for reference only

This product is RoHS compliant and Halide free.

Soldering Temperature Resistance:

[a] Package is IPC/JEDEC Std 020D Moisture Sensitivity Level 3

Dimension D does not include mold flash, protrusions or gate burrs. Mold flash, protrusions or gate burrs shall not exceed 0.15 mm per end. Dimension E does not include interlead flash or protrusion. Interlead flash or protrusion shall not exceed 0.25 mm per side.

The package top may be smaller than the package bottom. Dimensions D and E are determined at the outermost extremes of the plastic body exclusive of mold flash, tie bar burrs, gate burrs and interlead flash, but including any mismatch between the top and bottom of the plastic body.

7.0 Ordering Information

Part Number	Options	Package	Operating Temp. Range	Description
iW3620-00		SOIC-8	$-40^{\circ}\text{C} \leq T_A \leq 85^{\circ}\text{C}$	Tape & Reel ¹

Note 1: Tape & Reel packing quantity is 2,500/reel.

iW3620 Product Brief

Digital PWM Constant Current Controller for AC/DC LED Driver

iWatt

About iWatt

iWatt Inc. is a fabless semiconductor company that develops intelligent power management ICs for computer, communication, and consumer markets. The company's patented *pulseTrain*™ technology, the industry's first truly digital approach to power system regulation, is revolutionizing power supply design.

Trademark Information

© 2009 iWatt, Inc. All rights reserved. iWatt, the iW light bulb, *EZ-EMI* and *pulseTrain* are trademarks of iWatt, Inc. All other trademarks and registered trademarks are the property of their respective companies.

Contact Information

Web: <http://www.iwatt.com>

E-mail: info@iwatt.com

Phone: 408-374-4200

Fax: 408-341-0455

iWatt Inc.

101 Albright Way
Los Gatos CA 95032-1827

Disclaimer

iWatt reserves the right to make changes to its products and to discontinue products without notice. The applications information, schematic diagrams, and other reference information included herein is provided as a design aid only and are therefore provided as-is. iWatt makes no warranties with respect to this information and disclaims any implied warranties of merchantability or non-infringement of third-party intellectual property rights.

Certain applications using semiconductor products may involve potential risks of death, personal injury, or severe property or environmental damage ("Critical Applications").

IWATT SEMICONDUCTOR PRODUCTS ARE NOT DESIGNED, INTENDED, AUTHORIZED, OR WARRANTED TO BE SUITABLE FOR USE IN LIFE-SUPPORT APPLICATIONS, DEVICES OR SYSTEMS, OR OTHER CRITICAL APPLICATIONS.

Inclusion of iWatt products in critical applications is understood to be fully at the risk of the customer. Questions concerning potential risk applications should be directed to iWatt, Inc.

iWatt semiconductors are typically used in power supplies in which high voltages are present during operation. High-voltage safety precautions should be observed in design and operation to minimize the chance of injury.