

CONSTANT VOLTAGE AND CONSTANT CURRENT CONTROLLER AP4313**General Description**

The AP4313 is a highly integrated solution for a constant voltage/constant current mode SMPS application.

The AP4313 contains one 1.21V voltage reference with $\pm 1\%$ accuracy, one current sensing circuit and two operational amplifiers. Combining the voltage reference with one operational amplifier makes AP4313 an ideal voltage controller for use in adapters and battery chargers. The other low voltage reference combined with the other operational amplifier makes it an ideal current limiter for output low side current sensing.

The AP4313 is available in SOT-23-6 package.

Features

- Constant Voltage and Constant Current Control
- Precision Internal Voltage Reference
- Few External Components
- Easy Compensation
- Low Supply Current: 0.5mA
- Operating Temperature Range: -40 to 105°C

Applications

- Adapters
- Battery Chargers

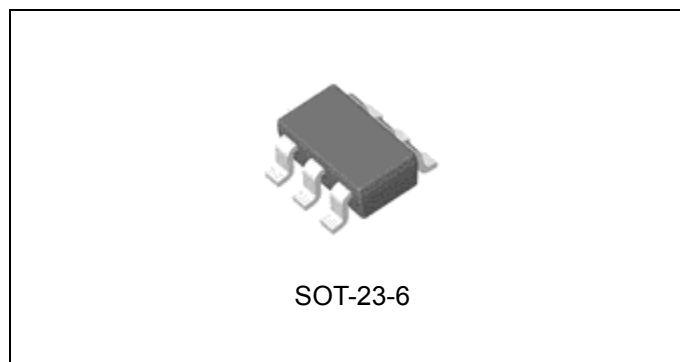

Figure 1. Package Type of AP4313

CONSTANT VOLTAGE AND CONSTANT CURRENT CONTROLLER AP4313

Pin Configuration

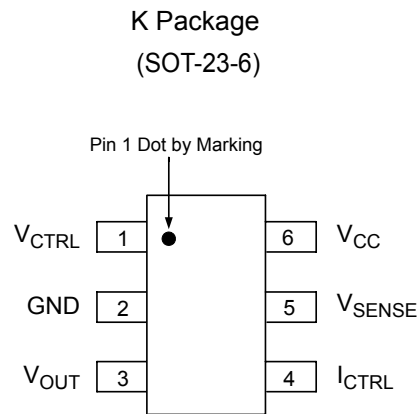

Figure 2. Pin Configuration of AP4313 (Top View)

Pin Description

Pin Number	Pin Name	Function
1	V_{CTRL}	Input pin of the voltage control loop
2	GND	Ground
3	V_{OUT}	Output pin. Sinking current only
4	I_{CTRL}	Input pin of the current control loop
5	V_{SENSE}	Input pin of the current control loop
6	V_{CC}	Power supply

**CONSTANT VOLTAGE AND CONSTANT CURRENT CONTROLLER AP4313****Absolute Maximum Ratings (Note 1)**

Parameter	Symbol	Value	Unit
Power Supply Voltage	V_{CC}	20	V
Input Voltage	V_{IN}	-0.3 to V_{CC}	V
Junction Temperature	T_J	150	°C
Storage Temperature	T_{STG}	-65 to 150	°C
Lead Temperature (Soldering, 5sec)	T_{LEAD}	260	°C
Package Thermal Resistance (Junction to Case)	θ_{JC}	92	°C/W

Note 1: Stresses greater than those listed under "Absolute Maximum Ratings" may cause permanent damage to the device. These are stress ratings only, and functional operation of the device at these or any other conditions beyond those indicated under "Recommended Operating Conditions" is not implied. Exposure to "Absolute Maximum Ratings" for extended periods may affect device reliability.

Recommended Operating Conditions

Parameter	Symbol	Min	Max	Unit
Power Supply Voltage	V_{CC}	2.5	18	V
Operating Temperature Range	T_A	-40	105	°C

**CONSTANT VOLTAGE AND CONSTANT CURRENT CONTROLLER AP4313****Electrical Characteristics**(V_{CC}=5V, T_A=25°C, unless otherwise specified.)

Parameter	Symbol	Conditions	Min	Typ	Max	Unit
TOTAL CURRENT CONSUMPTION						
Total Supply Current Not Including the Output Sinking Current	I _{CC}			0.6	1.2	mA
VOLTAGE CONTROL LOOP						
Transduction Gain (V _{CTRL}). Sink Current Only	G _{mv}		1	3.5		mA/mV
Voltage Control Loop Reference	V _{REF}		1.198	1.21	1.222	V
Input Bias Current (V _{CTRL})	I _{IBV}			50		nA
CURRENT CONTROL LOOP						
Transduction Gain (I _{CTRL}).	G _{mi}		1.5	7		mA/mV
Current Control Loop Reference	V _{SENSE}	I _{OUT} =2.5mA	196	200	204	mV
Current Out of Pin I _{CTRL} at -200mV	I _{IBI}			25		μA
OUTPUT STAGE						
Low Output Voltage at 10mA Sinking Current	V _{OL}			200		mV
Output Short Circuit Current. Output to V _{CC} . Sink Current Only	I _{OS}			27	50	mA



CONSTANT VOLTAGE AND CONSTANT CURRENT CONTROLLER AP4313

Typical Performance Characteristics

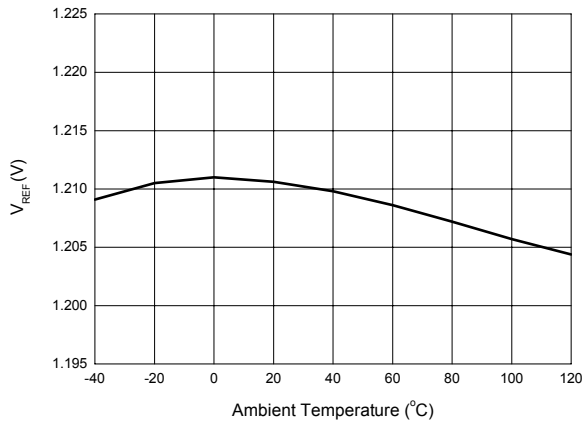

Figure 4. V_{REF} vs. Ambient Temperature

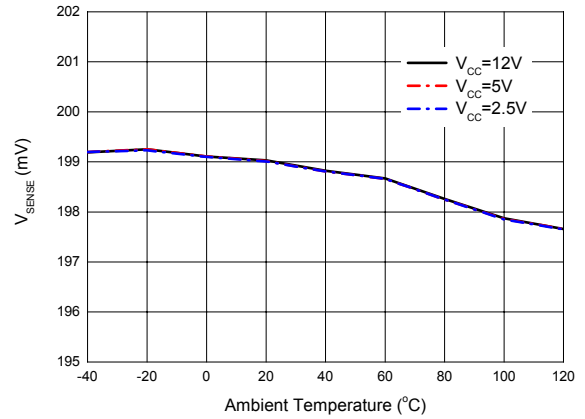

Figure 5. V_{SENSE} vs. Ambient Temperature

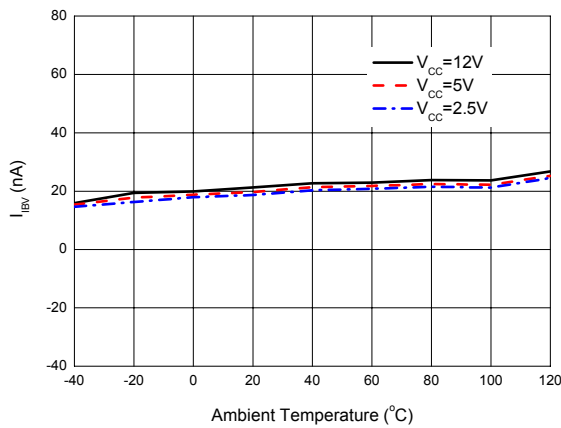

Figure 6. V_{CTRL} Pin Input Bias Current vs. Ambient Temperature

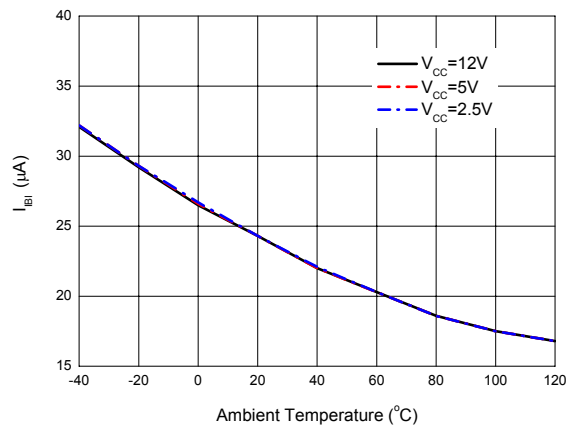

Figure 7. I_{CTRL} Pin Input Bias Current vs. Ambient Temperature



CONSTANT VOLTAGE AND CONSTANT CURRENT CONTROLLER AP4313

Typical Performance Characteristics (Continued)

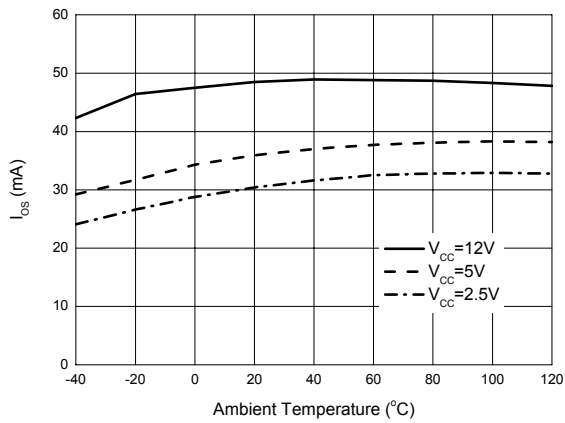

Figure 8. Output Short Circuit Current vs. Ambient Temperature

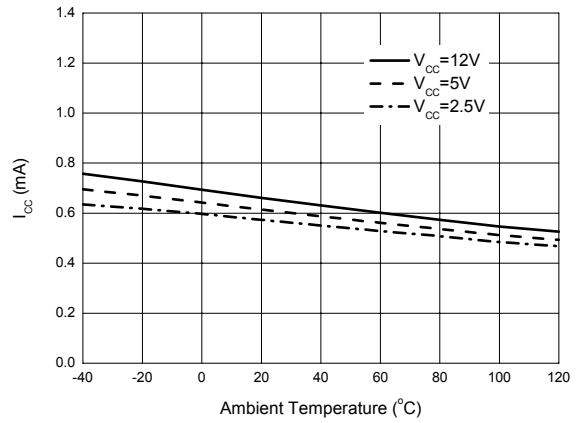
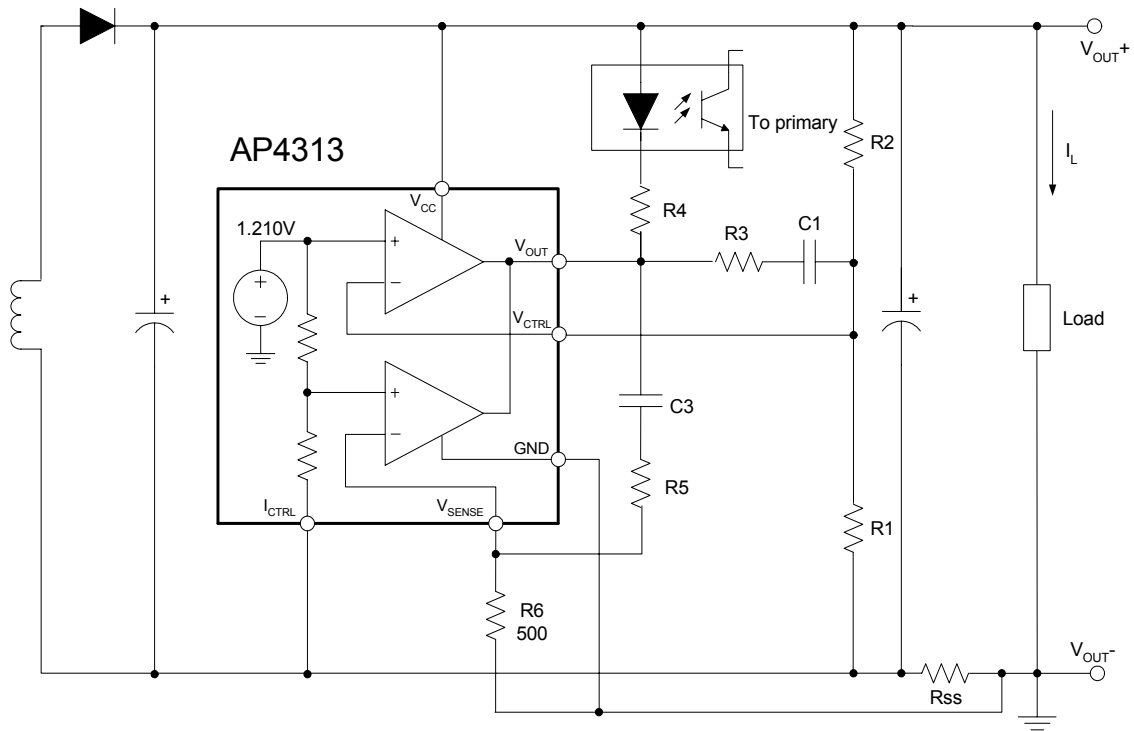

Figure 9. Supply Current vs. Ambient Temperature

CONSTANT VOLTAGE AND CONSTANT CURRENT CONTROLLER AP4313

Typical Application (Continued)



$$V_{OUT} = [V_{REF} + (I_L \times R_{SS})] \times \frac{R1 + R2}{R1} - (I_L \times R_{SS}) \quad (\text{V})$$

$$\text{CurrentLimit} = \frac{V_{SENSE}}{R_{SS}} \quad (\text{A})$$

Figure 11. Typical Application 2 of AP4313

CONSTANT VOLTAGE AND CONSTANT CURRENT CONTROLLER AP4313

Typical Application (Continued)

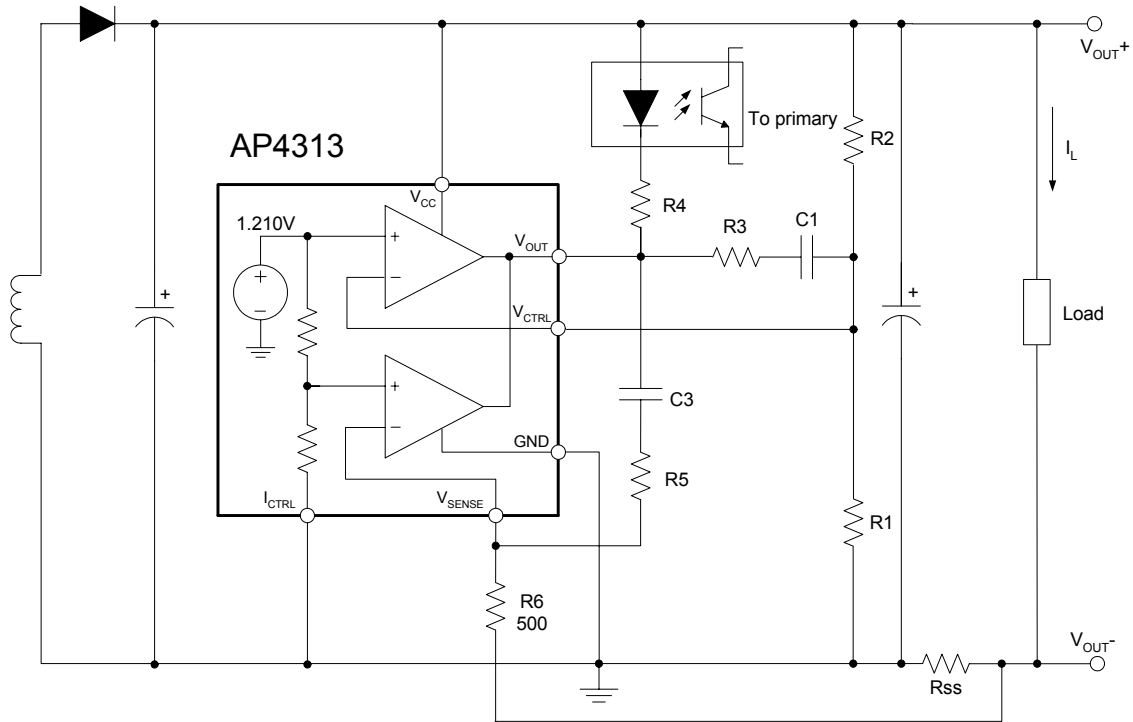

$$V_{OUT} = V_{REF} \times \frac{R1 + R2}{R1} - (I_L \times R_{SS}) \quad (V)$$

$$CurrentLimit = \frac{V_{SENSE} \times V_{REF}}{(V_{SENSE} + V_{REF}) \times R_{SS}} \quad (A)$$

Figure 12. Typical Application 3 of AP4313



CONSTANT VOLTAGE AND CONSTANT CURRENT CONTROLLER AP4313

Mechanical Dimensions

SOT-23-6

Unit: mm(inch)

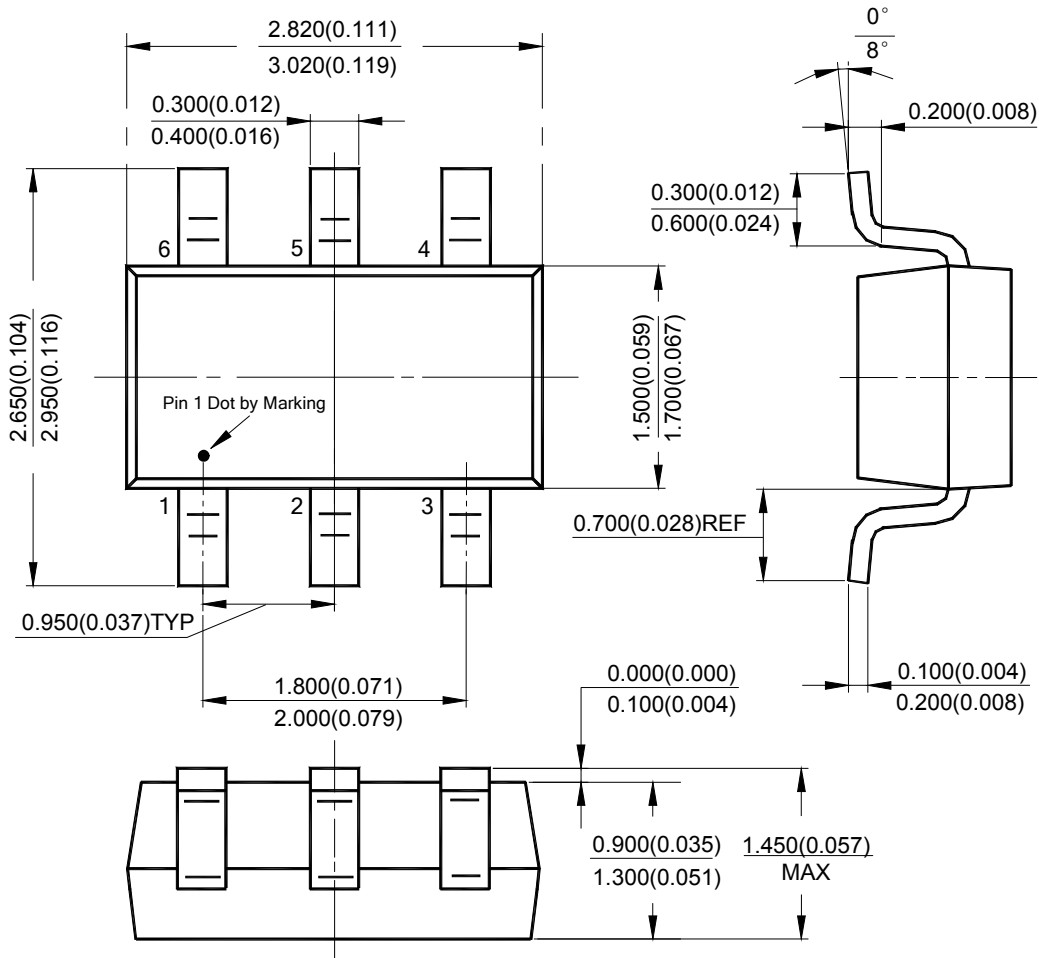



BCD Semiconductor Manufacturing Limited

<http://www.bcdsemi.com>

IMPORTANT NOTICE

BCD Semiconductor Manufacturing Limited reserves the right to make changes without further notice to any products or specifications herein. BCD Semiconductor Manufacturing Limited does not assume any responsibility for use of any its products for any particular purpose, nor does BCD Semiconductor Manufacturing Limited assume any liability arising out of the application or use of any its products or circuits. BCD Semiconductor Manufacturing Limited does not convey any license under its patent rights or other rights nor the rights of others.

MAIN SITE

- Headquarters

BCD Semiconductor Manufacturing Limited

No. 1600, Zi Xing Road, Shanghai Zizhu Science-based Industrial Park, 200241, China
Tel: +86-21-24162266, Fax: +86-21-24162277

- Wafer Fab

Shanghai SIM-BCD Semiconductor Manufacturing Co., Ltd.

800 Yi Shan Road, Shanghai 200233, China
Tel: +86-21-6485 1491, Fax: +86-21-5450 0008

REGIONAL SALES OFFICE

Shenzhen Office

Shanghai SIM-BCD Semiconductor Manufacturing Co., Ltd., Shenzhen Office
Room E, 5F, Noble Center, No.1006, 3rd Fuzhong Road, Futian District, Shenzhen,
518026, China
Tel: +86-755-8826 7951
Fax: +86-755-8826 7865

Taiwan Office

BCD Semiconductor (Taiwan) Company Limited
4F, 298-1, Rui Guang Road, Nei-Hu District, Taipei,
Taiwan
Tel: +886-2-2656 2808
Fax: +886-2-2656 2806

USA Office

BCD Semiconductor Corp.
30920 Huntwood Ave. Hayward,
CA 94544, USA
Tel : +1-510-324-2988
Fax: +1-510-324-2788