



High Voltage Multi-Topology LED Driver

Features

- High Voltage : VIN up to 36V, VOUT up to 36V
- 1.5A Switch Current
- Buck, Boost or Buck-Boost Operation
- Current Mode PWM with 1MHz Switching Frequency
- Easy dimming : Analog, PWM or PWM Converting to Analog with One External Capacitor
- Soft Start to Avoid Inrush Current
- Programmable Over Voltage Protection to Limit Output Voltage
- VIN Under Voltage Lockout and Thermal Shut-down
- 12-Lead TDFN Package

General Description

The G2602 is a current mode DC/DC converter with an internal 1.5A, 40V switch specifically designed to drive LEDs. The G2602 operates as a LED driver in buck, boost and buck-boost mode. The LED current is externally programmable with a 120mV sense resistor. With a 1MHz operating frequency, the external inductor and input/output capacitors can all be small. Dimming can be either analog, PWM, or PWM converting to analog with an external capacitor.

The G2602 is available in a TDFN-12L 3x3 package.

Applications

- GPS, Portable DVD Backlight
- Desk Light and Room Lighting
- Industrial Display Backlight

Ordering Information

ORDER NUMBER	MARKING	TEMP. RANGE	PACKAGE (Green)
G2602RQ1U	2602	-40°C to +85°C	TDFN3X3-12

Note: RQ: TDFN3X3-12

1: Bonding Code

U: Tape & Reel

Pin Configuration

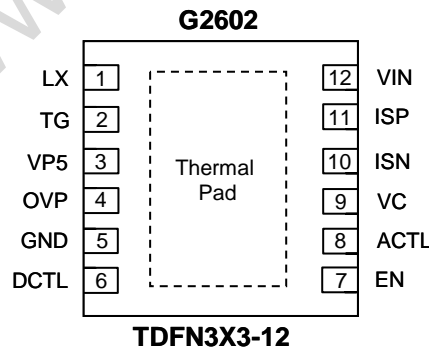

Note: Recommend connecting the Thermal Pad to the Ground for excellent power dissipation.



Absolute Maximum Ratings

VIN, ISP, ISN, LX 40V
 VC, ACTL, DCTL, EN, OVP, TG, VP5 5V
 Thermal Resistance of Junction to Ambient (θ_{JA})*
 TDFN3X3-12 60°C/W
 Continuous Power Dissipation ($T_A = +25^\circ\text{C}$)*
 TDFN3X3-12 1.667W
 Junction Temperature 150°C
 Storage Temperature -65°C to 150°C
 Reflow Temperature (soldering, 10sec) 260°C

Recommended Operation conditions

VIN, ISP, ISN 6.5V to 36V
 Junction Temperature Range -40°C to 125°C
 Ambient Temperature Range -40°C to 85°C

* Please refer to Minimum Footprint PCB Layout Section.

Electrical Characteristics

(VIN=12V, $T_A=25^\circ\text{C}$.)

The device is not guaranteed to function outside its operating conditions. Parameters with MIN and/or MAX limits are 100% tested at +25°C, unless otherwise specified.

Parameter	Symbol	Conditions	Min	Typ	Max	Unit
Supply Voltage	VIN		6.5	---	36	V
Under Voltage Threshold	UVLO	VIN falling	5.8	6	6.2	V
Supply Current	IVCC	VC=0V (Switching off)	---	0.6	---	mA
Shutdown Current	ISHDN	EN=0V	---	12	---	μA
EN Input Level	VIH		1.5	---	VP5	V
	VIL		---	---	0.5	V
EN Output Current	IEN1	EN=0V, current out of pin	---	0.5	---	μA
EN Input Current	IEN2	EN=5V	---	2	---	μA
Input Threshold (VISP-VISN)		6.5V < common mode < 36V	114	120	126	mV
ISP Input Current	IISP	VISP=24V	---	100	---	μA
ISN Input Current	IISN	VISN=24V	---	---	1	μA
ACTL Output Current	IACTL1	VACTL=0V, current out of pin (DCTL floating)	---	12	---	μA
ACTL Input Current	IACTL2	VACTL=5V	---	50	---	μA
LED Current Off Threshold at ACTL	VACTL		---	50	---	mV
DCTL Output Current	IDCTL1	VDCTL=0V, current out of pin	---	0.5	---	μA
DCTL Input Current	IDCTL2	VDCTL=5V	---	2	---	μA
DCTL Input Level	VIH		1.5	---	---	V
	VIL		---	---	0.5	V
Switching Frequency	FOSC		800K	1M	1.2M	Hz
Maximum Duty Cycle			90	92	---	%
LX ON Resistance	RLX	ILX=500mA	---	0.3	---	Ω
LX Leakage Current		VLX=40V, EN=0V	---	---	5	μA
Over-Current Protection	IOCP		1.25	1.5	---	A
OVP Threshold	VOVP		---	1.2	---	V
OVP Input Current	IOVP	VOVP=1.2V	---	---	0.1	μA
TG Output Low	VOL		---	0	---	V
TG Output High	VOH		---	VP5	---	V
VP5 Regulation Voltage	VP5		---	5	---	V
Thermal shutdown	OTP		---	150	---	°C
OTP Hysteresis			---	30	---	°C



Minimum Footprint PCB Layout Section

TDFN3X3-12

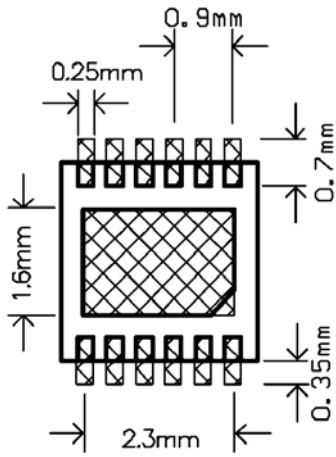

www.gofotech.com



Pin Description

PIN	NAME	FUNCTION
1	LX	Switch Pin.
2	TG	Gate Driver Output for the true shutdown NMOS switch. Only for Boost Converter.
3	VP5	A regulated voltage for internal circuits. A capacitor of at least 1uF is required.
4	OVP	Over voltage protection. Boost and Buck-Boost converter turn off when VOVP goes higher than 1.2V.
5	GND	Ground.
6	DCTL	PWM Dimming Control. By Adding a Filtering Capacitor on ACTL Pin, the PWM dimming signal on ACTL pin will be averaged and converted into analog dimming signal.
7	EN	Chip Enable (Active High). When low, chip is in shutdown mode.
8	ACTL	Analog Dimming Control.
9	VC	Gm Error Amplifier Output Pin. Adding an RC network on this pin for stabilization.
10	ISN	Current Sense Negative Input.
11	ISP	Current Sense Positive Input.
12	VIN	Power Supply of the chip.
13 Thermal Pad		The thermal pad must be soldered to a large PCB and connected to GND for maximum power dissipation.

www.gofotech.com

Application Information

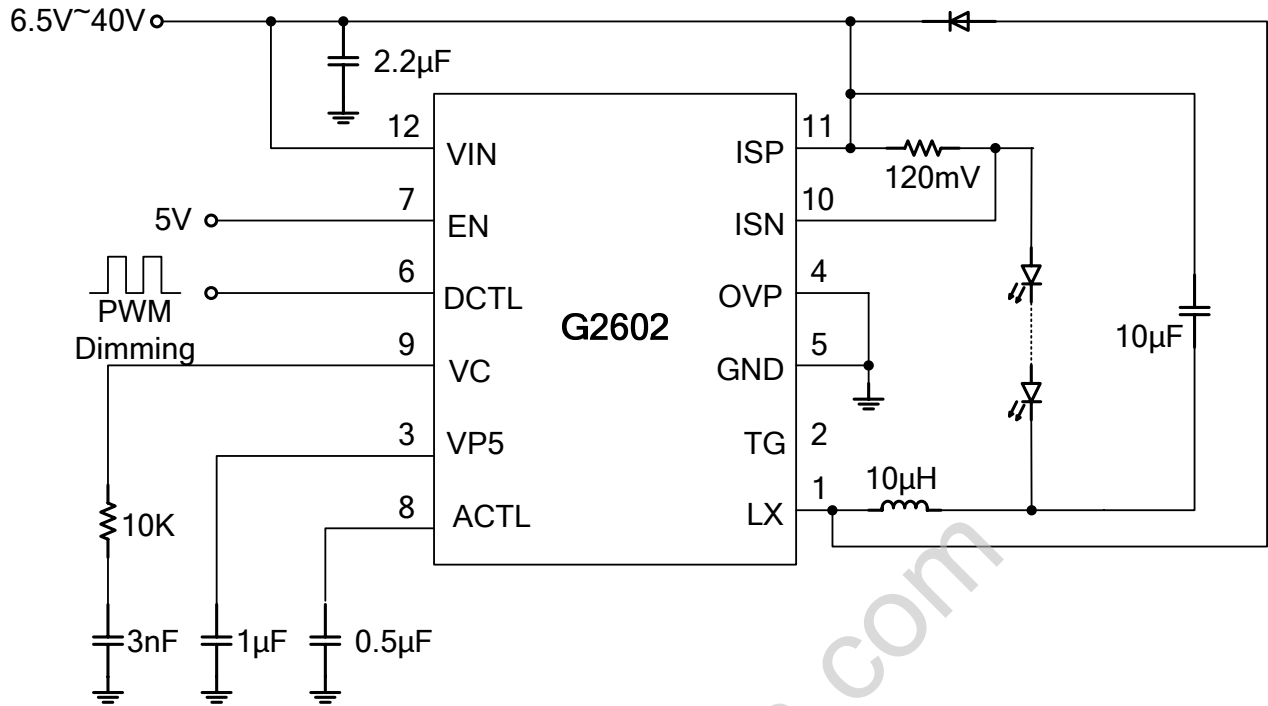

Fig. 1 PWM to Analog Dimming BUCK Configuration

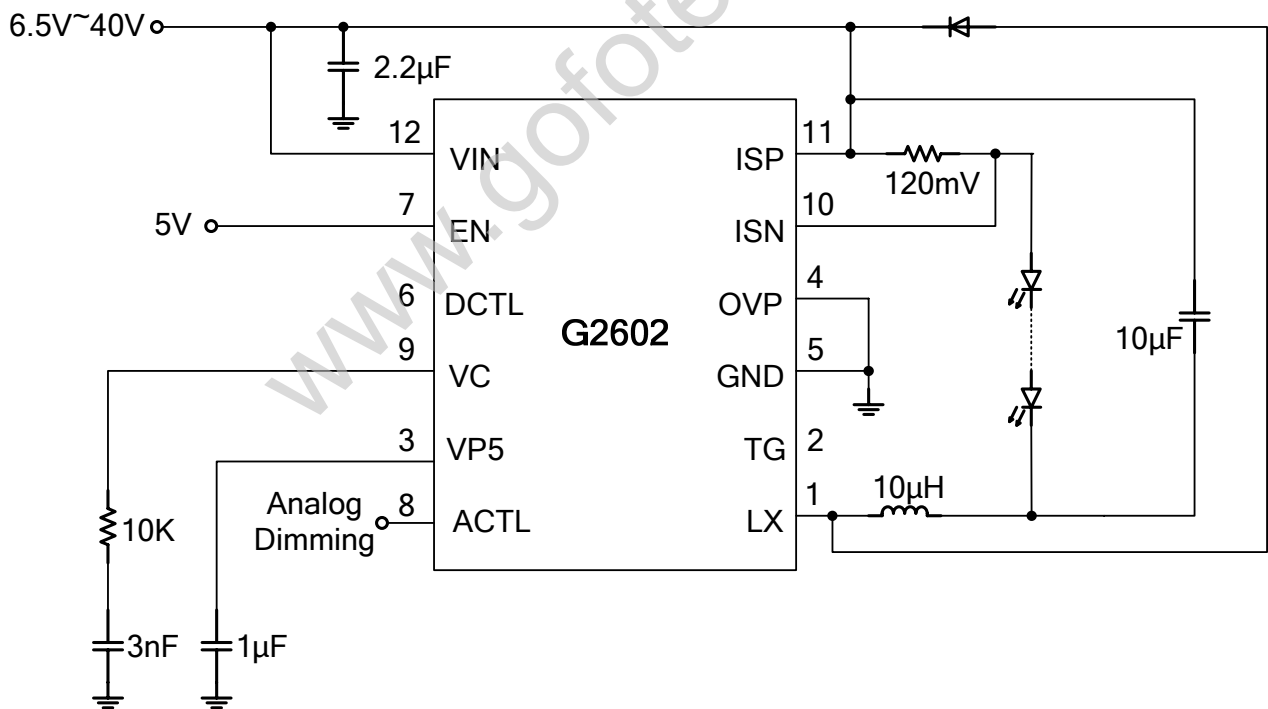

Fig. 2 Analog Dimming BUCK Configuration

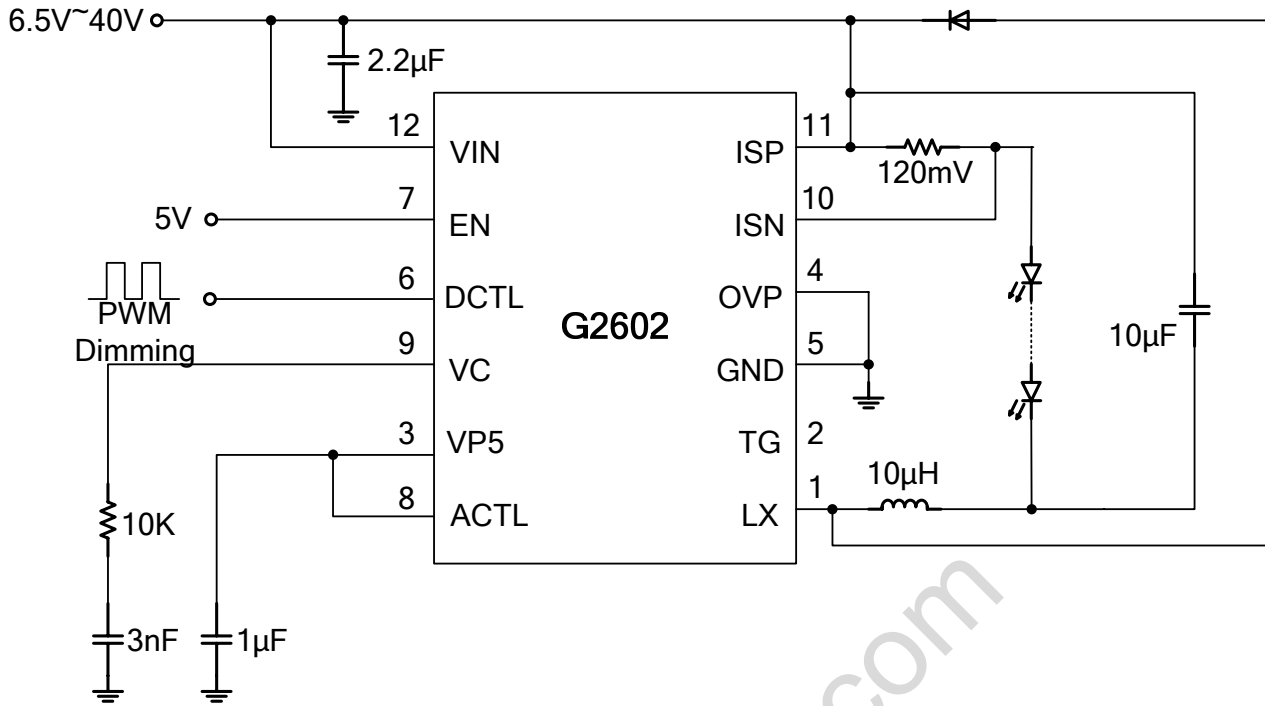

Fig. 3 PWM Dimming BUCK Configuration

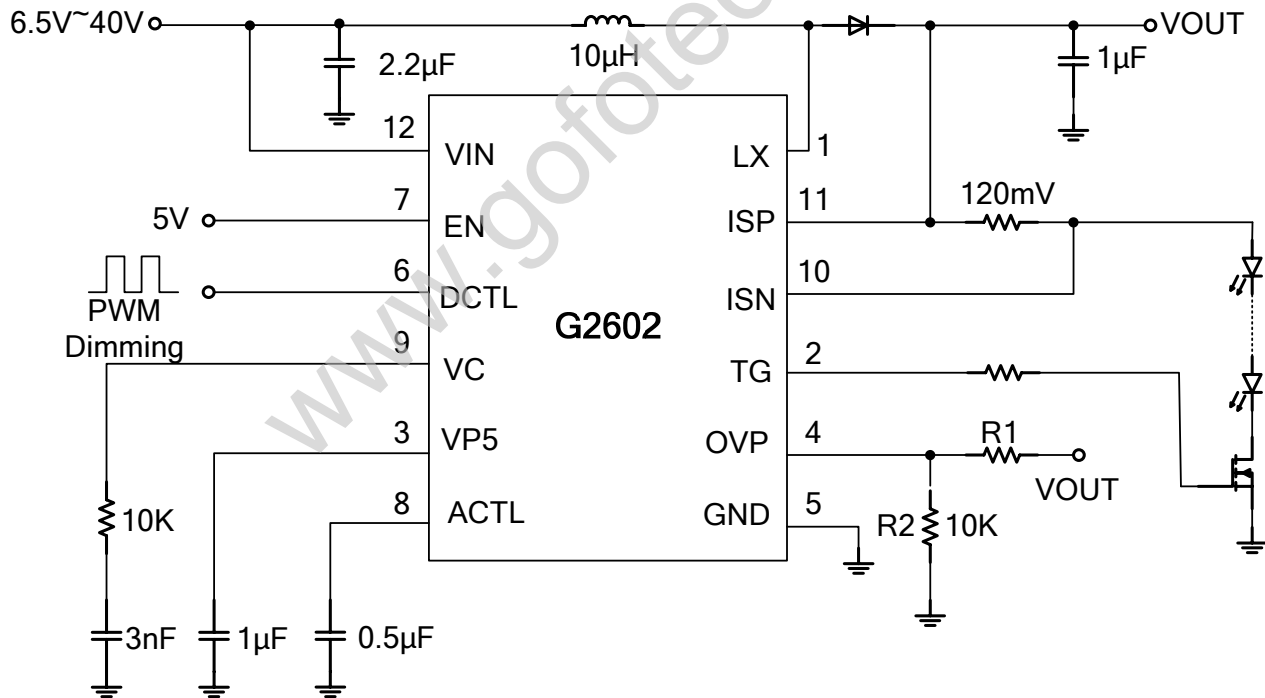

Fig. 4 PWM to Analog Dimming Boost Configuration

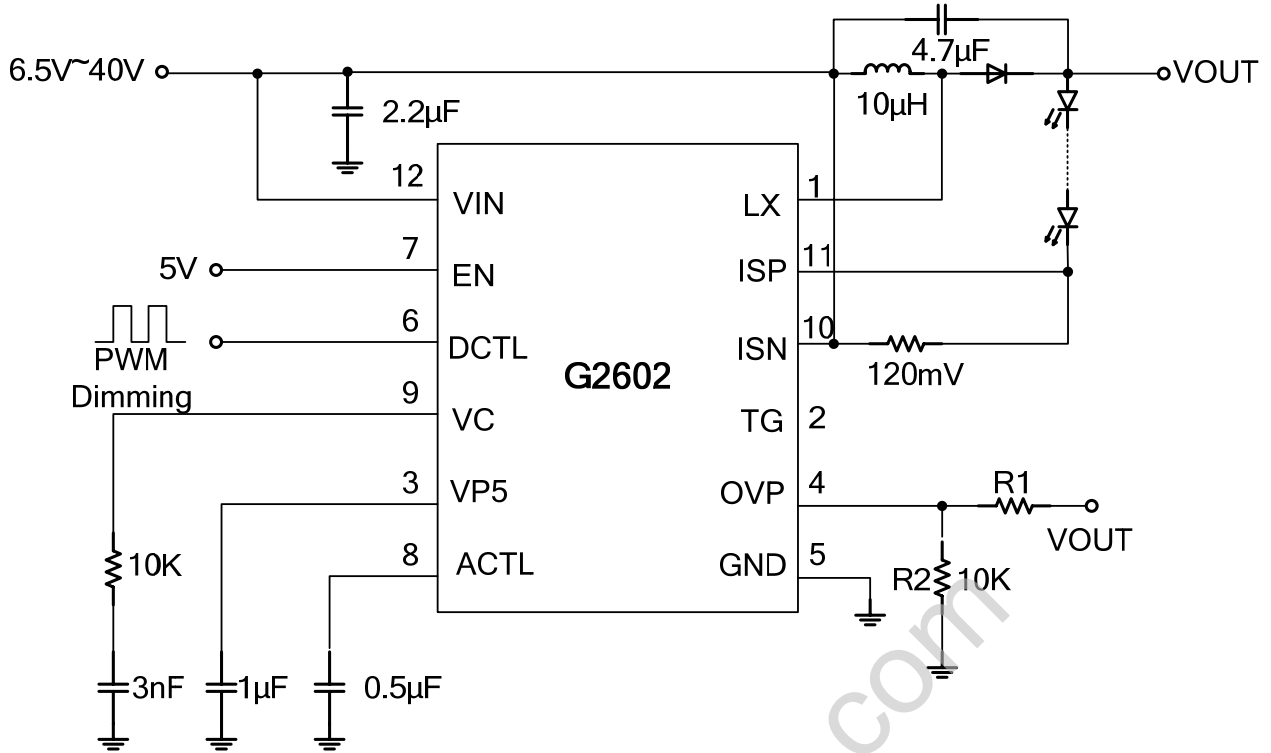

Fig. 5 PWM to Analog Dimming Buck-Boost Configuration

www.gofotech.com



Block Diagram

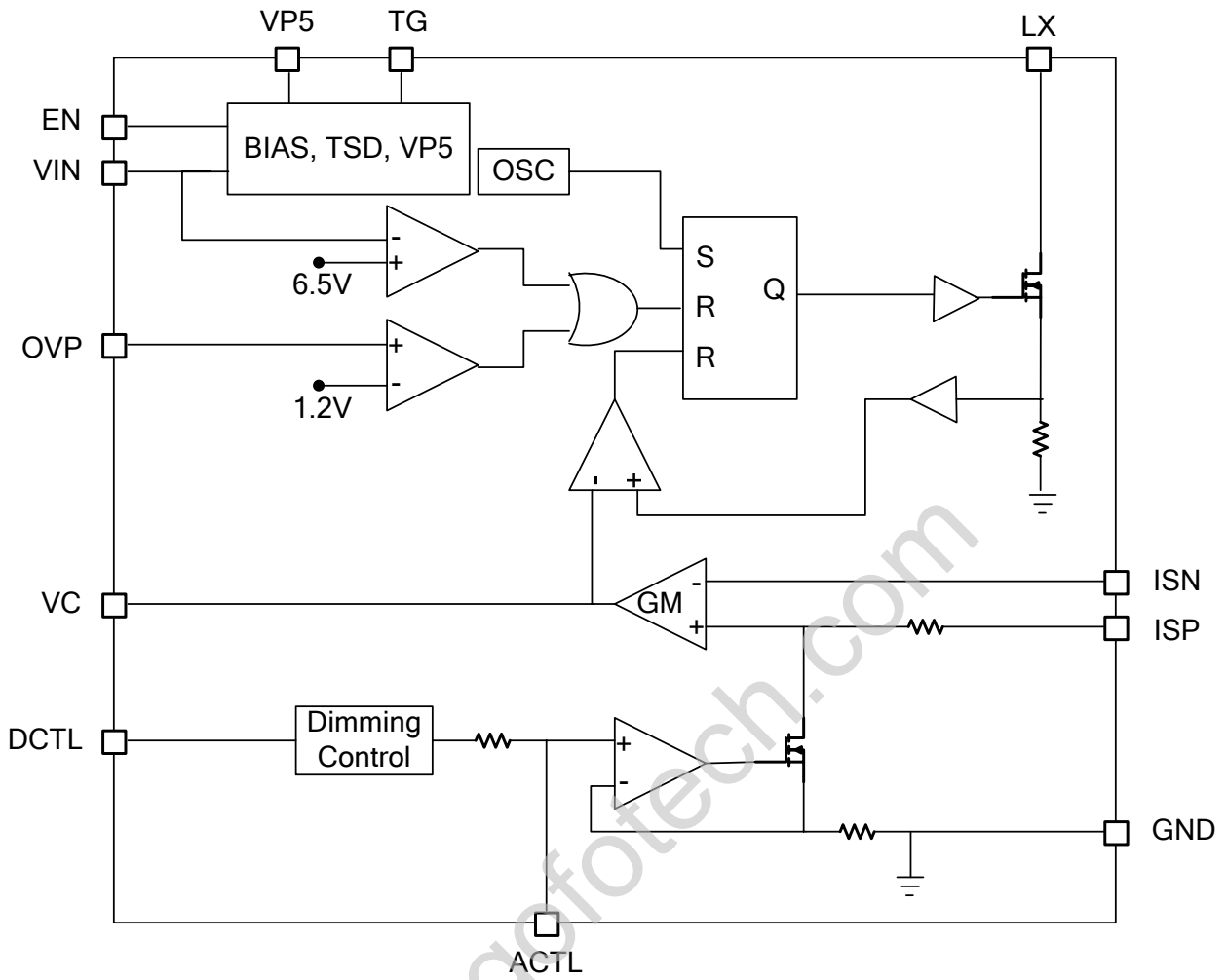

Fig. 6 Block Diagram of G2602



Detailed Description

Dimming Control

There are three methods to control the LED current for dimming using the G2602. The first method uses the ACTL pin to linearly adjust the current sense threshold. When the ACTL pin voltage is less than 1.2V, the LED current is:

$$I_{LED} = \frac{V_{ACTL}}{10 \times R_{SENSE}}$$

When V_{ACTL} is higher than 1.2V, the LED current is clamped to be:

$$I_{LED} = \frac{120mV}{R_{SENSE}}$$

The second method of dimming control uses DCTL pin to modulate V_{ACTL} between 0 and 1.2V. With one external capacitor connected to ACTL pin, V_{ACTL} is averaged and converted to analog signal. The third method of dimming control uses DCTL pin to modulate the LED current between 0 and full current. In this method, the ACTL pin is tied to the VP5 pin.

Enable Control

If floating, the EN pin is internally pulled high after VIN power on, enabling the IC.

UVLO

The G2602 enters normal operation when VIN rises above approximately 6.5V. When VIN falls below 6V, under-voltage lockout (UVLO) inhibits switching.

Programmable Over-Voltage Protection

In boost and buck-boost mode, the Over-Voltage Protection threshold can be adjusted by connecting the OVP pin to a resistor divider between VOUT and GND. Choose $R2=10k\Omega$ and solve the $R1$ with the equation:

$$R1 = R2 \times \left(\frac{V_{OUT}}{1.2} - 1 \right)$$

If VOUT is above the threshold or LEDs are disconnected from the circuit, VISP-VISN is similar to zero with a sense resistor. This will cause N-MOS to switch with a maximum duty cycle and come out output over-voltage. This may cause the LX pin voltage to exceed its maximum voltage rating to damage built-in N-MOS. In the state, the OVP protection circuitry stops the internal N-MOS. When VOUT falls below the threshold, IC will automatically recover normal operation.

Cycle-by-Cycle Over-Current Protection

The G2602 provides cycle-by-cycle over-current protection. Current limit is accomplished using a separate dedicated comparator. The cycle-by-cycle current limit abbreviates the on-time of the N-MOS in event that the current of flowing N-MOS is greater than the current limit value. The current-limit feature protects against a hard short or over-current fault at the output.

Soft-Start

Soft-start allows a gradual increase of the internal current-limit level for the converter during power-up to reduce input surge current. As the internal current source charges the internal soft-start capacitor, the peak N-MOS current is limited by the voltage on the capacitor. In another story, when toggle or a logic-level transition on EN pin from low to high, soft-start function must work to enable constant current charging internal capacitor.

Thermal Shutdown Protection

Thermal shutdown protection limits total power dissipation in the G2602. When the junction temperature exceeds 150°C, a thermal sensor activates the thermal protection, which shuts down the IC, allowing the IC to cool. Once the device cools down by 30°C, IC will automatically recover normal operation. For continuous operation, do not exceed the absolute maximum junction-temperature rating.



Application Information

Inductor Selection

In the buck mode, the inductor value is determined as follows:

$$L = \frac{V_{LED}(V_{IN} - V_{LED})}{V_{IN} \times f \times \Delta I_{LPP}}$$

Where ΔI_{LPP} is defined as inductor ripple current.

V_{LED} is the voltage across the LED string, V_{IN} is the input voltage to the converter, and f is the switching frequency.

In the boost mode, the inductor value is determined as follows:

$$L = \frac{V_{IN}(V_{LED} - V_{IN})}{V_{LED} \times f \times \Delta I_{LPP}}$$

In G2602, a 10 μ H inductor is recommended.

Input Capacitor Selection

For proper operation, it is necessary to place a bypass capacitor to GND close to the VIN pin of the G2602. The input capacitor must meet the ripple current requirement (I_{RMS}) imposed by the switching currents.

$$I_{RMS} = I_{LED} \sqrt{(1-D)D}$$

A 1 μ F or greater capacitor with low ESR should be used. X5R and X7R capacitor types are ideal due to their stability across temperature range.

Output Capacitor Selection

The selection of output capacitor depends on the load and converter configuration. Output ripple voltage requirements also determine the value and type of capacitors. X5R and X7R capacitor types are ideal due to their stability across temperature range.

Loop compensation

The G2602 uses an internal transconductance error amplifier whose V_C output compensates the control loop. The external inductor, output capacitor, and the compensation resistor and capacitor determine the loop stability. The inductor and output capacitor are chosen based on performance, size and cost. The compensation resistor and capacitor at V_C are selected to optimize control loop stability.

Diode Selection

The Schottky diode conducts current during the interval when the switch is turned off. Select a diode rated for the maximum LX voltage.

VP5 Regulator Stabilization

The VP5 pin requires a capacitor for stable operation. Place the capacitor close to the IC to minimize the trace length to the VP5 pin and also to the IC ground. A 1 μ F capacitor is usually sufficient.

Thermal Consideration

Careful attention must be paid to the internal power dissipation of the G2602 at higher input voltages to ensure that the maximum junction temperature is not exceeded. This junction limit is especially important when operating at high ambient temperatures.

Layout Considerations

- It is crucial to achieve a good electrical and thermal contact between the Exposed Pad and the ground plane of the board.
- To reduce electromagnetic interference (EMI), it is important to minimize the area of the LX node.
- Since there is a small DC input bias current to the ISP and ISN inputs, resistance in series with these inputs should be minimized and matched, otherwise there will be an offset.
- The ceramic bypass capacitor should be placed as close as possible to the VIN pin.



Package Information

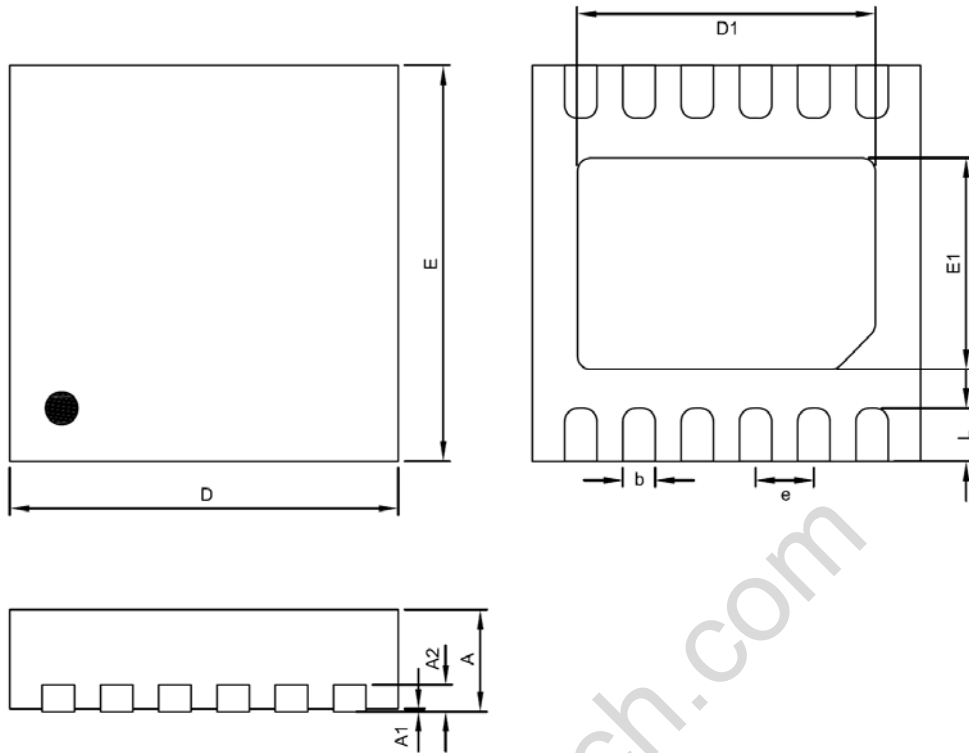

TDFN3X3-12 Package

Symble	DIMENSION IN MM			DIMENSION IN INCH		
	MIN.	NOM.	MAX.	MIN.	NOM.	MAX.
A	0.70	0.75	0.80	0.0276	0.0295	0.0315
A1	0.00	---	0.05	0.0000	---	0.0020
A2	0.19	0.20	0.21	0.0075	0.0079	0.0083
D	2.95	3.00	3.05	0.1161	0.1181	0.1201
E	2.95	3.00	3.05	0.1161	0.1181	0.1201
D1	2.30	2.40	2.50	0.0906	0.0945	0.0984
E1	1.60	1.70	1.80	0.0630	0.0669	0.0709
b	0.18	0.25	0.30	0.0071	0.0098	0.0118
e	0.45 BSC			0.0177 BSC		
L	0.35	0.42	0.47	0.0138	0.0165	0.0185

Taping Specification

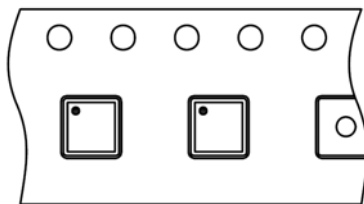

Feed Direction

PACKAGE	Q'TY/REEL
TDFN3X3-12	3,000 ea

GMT Inc. does not assume any responsibility for use of any circuitry described, no circuit patent licenses are implied and GMT Inc. reserves the right at any time without notice to change said circuitry and specifications.