

MOSFET Modules

250V
500V

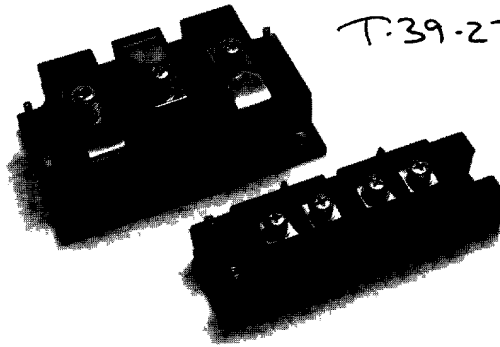

MOSFET Module advantages:

- Increase carrier frequencies
- Improve control accuracy

MOSFET Modules are used on:

- Switch-mode power supplies (SMPS)
- Linear power supplies (no secondary breakdown)
- High-performance motor controls
- Uninterruptible power supplies (UPS)
- Other high-frequency (>20kHz) applications

MOSFET Modules are designed for:

- 120VAC (250V) and 240VAC (500V) systems
- Currents of 50A, 100A, & 200A
- Typical switching frequencies of >20kHz
- Split-dual and standard-dual package topologies

MOSFET modules are voltage-controlled devices requiring very low gate-drive power. Ultra-fast switching devices, they are particularly well suited for low voltage (120VAC, 240VAC) applications. Not only are MOSFET modules excellent for high-frequency switching, but also in linear applications, where the absence of forward-biased secondary breakdown is an asset. MOSFET modules are supplied with or without Schottky forward and fast-recovery antiparallel diodes. Gate drive hybrids are also available to simplify designs.

MOSFET Modules

FUJI Semiconductors • Imported and Distributed by
Collmer Semiconductor, Inc.

14368 PROTON RD • DALLAS, TEXAS 75244 • 214/233-1589
FAX 214/233-0481



MOSFET Modules

Device Type	Ratings at $T_C = 25^\circ\text{C}$			Characteristics at $T_C = 25^\circ\text{C}$				Package
	Drain-Source Voltage V_{DS} (V)	Drain Current I_D (A)	Power Dissipation P_D (W)	Drain-Source On-State Resistance $r_{DS(on)}$ (m Ω)	Forward Transfer Conductance g_{fs} (S)	Switching Times		
						t_{on} (ns)	t_{off} (ns)	
2MI50F-050	500	50	400	110	45	530	780	Module
2MI50S-050	500	50	400	110	45	530	780	Module
2MI100F-025	250	100	400	32	55	-	-	Module
2MI100F-050	500	100	800	62	105	185	630	M210
2MI200F-025	250	200	800	15	150	175	600	M210
6MI15FS-050	500	15	60	400	13	130	560	SIL
6MI20FS-025	250	20	40	160	12	80	300	SIL

2MI50F-050 Ratings and Characteristics

ABSOLUTE MAXIMUM RATINGS AT $T_C = 25^\circ\text{C}$

Parameter	Symbols	Ratings	Units
Drain-Source Voltage	V_{DS}	500	V
Drain Current	I_D	50	A
Pulsed Drain Current	I_D (puls)	150	A
Reverse Drain Current	I_{DR}	50	A
Gate-Source Voltage	V_{GS}	± 20	V
Power Dissipation	P_D	400	W
Maximum Junction Temperature	T_J	150	$^\circ\text{C}$
Storage Temperature	T_{stg}	-40 to +125	$^\circ\text{C}$
Isolation Voltage	V_{iso}	2500	V

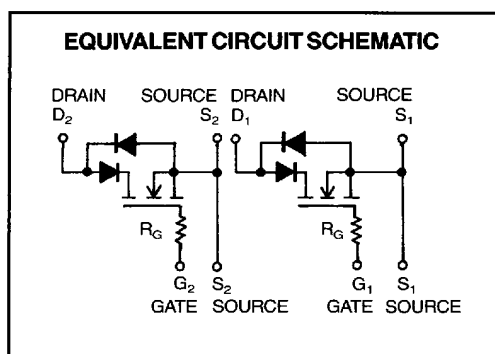

ELECTRICAL CHARACTERISTICS at $T_C = 25^\circ\text{C}$

Parameter	Symbols	Test Conditions	Min	Typ	Max	Units
Drain-Source Breakdown Voltage	$V_{(BR) DSS}$	$V_{GS} = 0V, I_D = 1mA$	500			V
Gate-Source Threshold Voltage	$V_{GS(th)}$	$V_{DS} = V_{GS}, I_D = 10mA$	2.1	3.0	4.0	V
Off-State Drain Current	I_{DSS}	$V_{GS} = 0V, V_{DS} = 500V, T_J = 25^\circ\text{C}$			1.0	mA
Gate Leakage Current	I_{GSS}	$V_{DS} = 0V, V_{GS} = \pm 20V$			100	nA
Drain-Source On-State Resistance	$r_{DS(on)}$	$V_{GS} = 15V, I_D = 25A$			110	m Ω
Forward Transfer Conductance	g_{fs}	$V_{DS} = 25V, I_D = 25A$		45		S
Input Capacitance	C_{iss}	$V_{GS} = 0V$		7.8	13	nF
Output Capacitance	C_{oss}	$V_{DS} = 25V$		0.9	1.5	
Reverse Transfer Capacitance	C_{rss}	$f = 1\text{ MHz}$		0.4	0.6	
Switching Turn-On Delay Time	$t_d(on)$	$V_{CC} = 100V, R_G = 5\Omega$		250	350	ns
Switching Rise Time	t_r			280	400	
Switching Turn-Off Delay Time	$t_d(off)$	$I_D = 25A, t_p = 20\mu s$		700	1000	
Switching Fall Time	t_f		$V_{GS} = 15V$		80	
Source-Drain Voltage	V_{SD}	$I_F = 50A, V_{GS} = 0V$		1.4	1.8	V
Reverse Recovery Time	t_{rr}	$I_F = 50A, -di/dt = 100A/\mu s, V_{GS} = 0V$			150	ns
Reverse Recovery Charge	Q_{rr}	$I_F = 50A, -di/dt = 100A/\mu s, V_{GS} = 0V$			1.0	μC

THERMAL CHARACTERISTICS

Parameter	Symbols	Test Conditions	Min	Typ	Max	Units
Thermal Resistance, Junction to case	$R_{\theta JC}$	Channel-to-Case			0.312	$^\circ\text{C/W}$
Thermal Resistance, Junction to Case (Schottky Diode)	$R_{\theta JC}$	Junction-to-Case			1.56	$^\circ\text{C/W}$
Thermal Resistance, Case to Fin	$R_{\theta CF}$	Case-to-Fin		0.06		$^\circ\text{C/W}$



TYPICAL CHARACTERISTICS OF A 2MI50F-050 MODULE

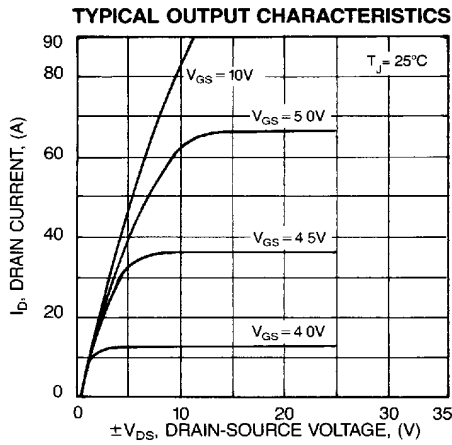

FIG. 1

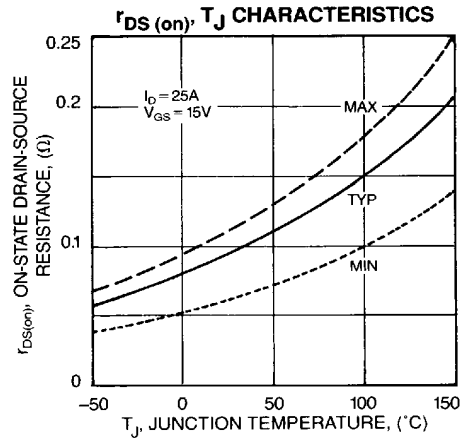

FIG. 2

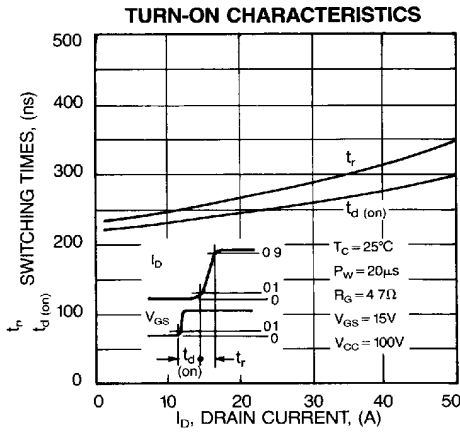

FIG. 3

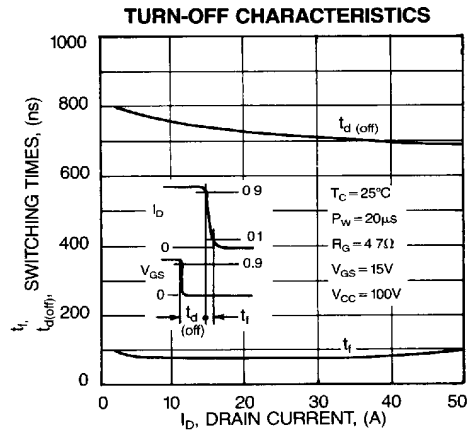

FIG. 4

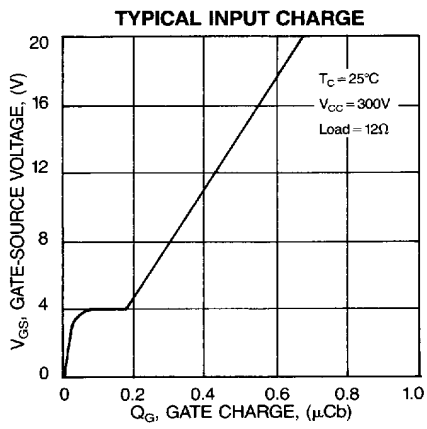

FIG. 5

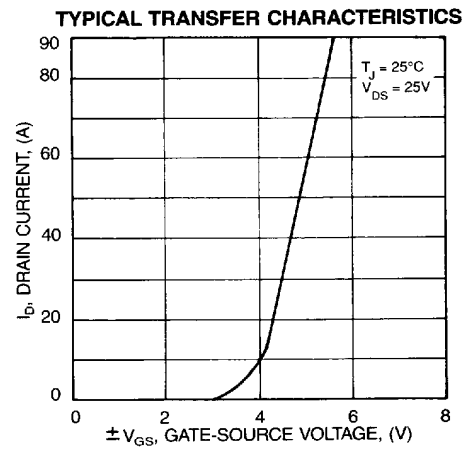

FIG. 6

MOSFET Modules

FUJII Semiconductors • Imported and Distributed by

Collmer Semiconductor, Inc.

14368 PROTON RD • DALLAS, TEXAS 75244 • 214/233-1589



TYPICAL CHARACTERISTICS OF A 2M150F-050 MODULE

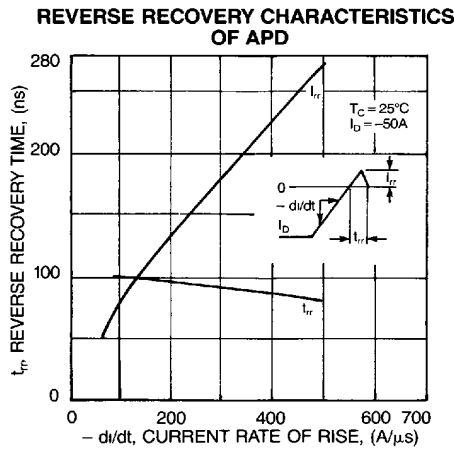
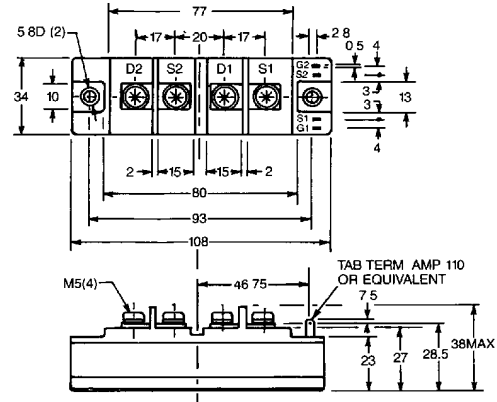

FIG. 7

OUTLINE DRAWINGS (DIMENSIONS IN MILLIMETERS)



MODULE

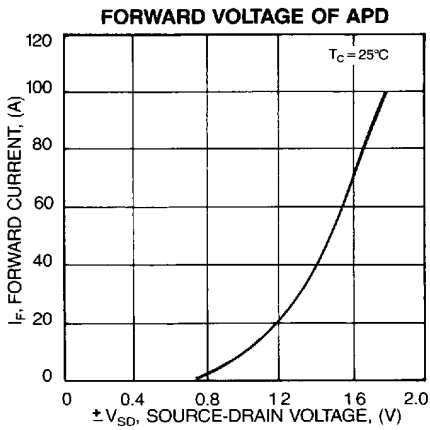
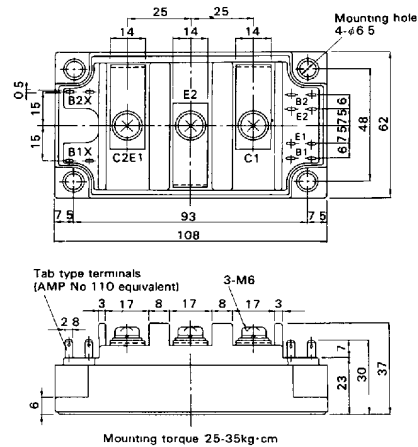

FIG. 8



M210

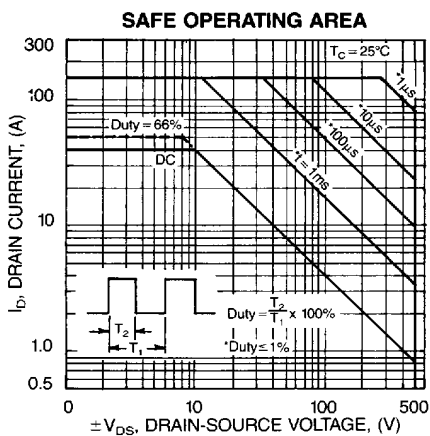
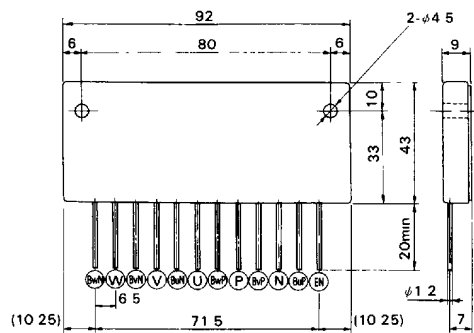

FIG. 9



SIL

COLLMER SEMICONDUCTOR, INC reserves the right to make changes in these specifications at any time and without notice in order to supply the best product possible

©1991 • COLLMER SEMICONDUCTOR, INC. • Printed in U.S.A.

4