

PWM Control 5A Step-Down Converter

❖ GENERAL DESCRIPTION

AX3116 consists of step-down switching regulator with PWM control. These device include a reference voltage source, oscillation circuit, error amplifier, internal PMOS and etc.

AX3116 provides low-ripple power, high efficiency, and excellent transient characteristics. The PWM control circuit is able to the duty ratio linearly form 0 up to 100%. An enable function, an over current protect function and short circuit protect function are built inside, and when OCP or SCP happens, the operation frequency will be reduced. Also, an internal compensation block is built in to minimum external component count.

With the addition of an internal P-channel Power MOS, a coil, capacitors, and a diode connected externally, these ICs can function as step-down switching regulators. They serve as ideal power supply units for portable devices when coupled with the SOP-8L-EP package, providing such outstanding features as low current consumption. Since this converter can accommodate an input voltage up to 23V, it is also suitable for the operation via an AC adapter.

❖ FEATURES

- Input voltage : 4.5V to 23V
- Output voltage : 0.8V to Vcc
- Duty ratio : 0% to 100% PWM control
- Oscillation frequency : 330KHz typ.
- Current Limit (CL), Enable function.
- External Soft-Start function.
- Thermal Shutdown function.
- Short Circuit Protect (SCP).
- Built-in internal SW P-channel MOS.
- SOP-8L with Exposed Pad Pb-Free package.

❖ Block Diagram

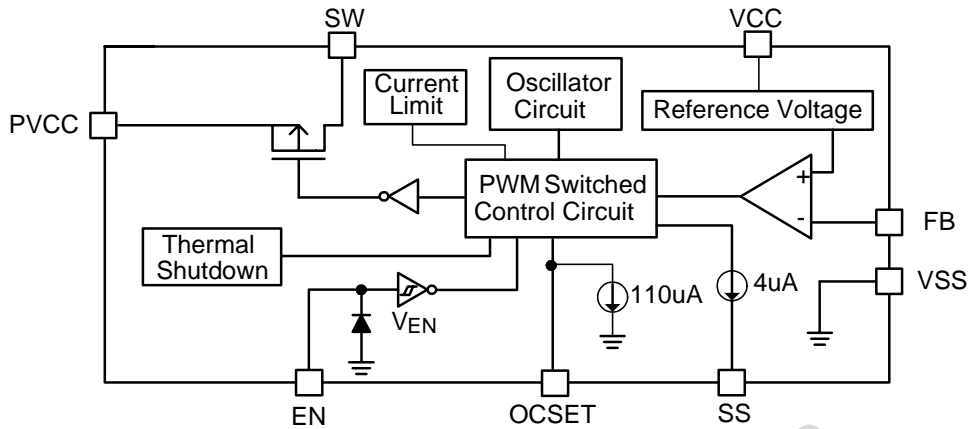

❖ PIN ASSIGNMET

The package of AX3116 is SOP-8L-EP; the pin assignment is given by:

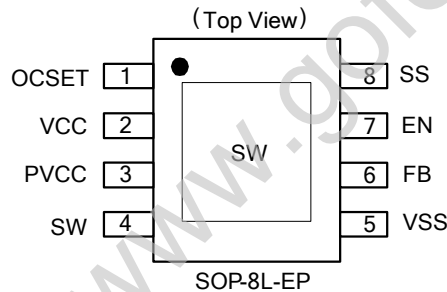

Name	Description
FB	Feedback pin
EN	Power-off pin H : normal operation(Step-down) L : Step-down operation stopped (All circuits deactivated)
SS	Soft-Start pin
VCC	IC power supply pin
PVCC	Driver power supply pin
SW	Switch pin. Connect external inductor/diode here.
VSS	GND pin
OCSET	Add an external resistor to set max switch output current.

❖ ORDER/MARKING INFORMATION

Order Information	Top Marking
<p>AX3116 X X X</p> <p>Frequency Package Type Packing</p> <p>Blank : 330Khz ES: SOP-8L-EP Blank : Tube A : Taping</p>	<p>Logo ← AX 3116 → Part number</p> <p>X X X X X → ID code: internal</p> <p>WW: 01~52</p> <p>Year : 07 = 2007</p>



❖ **Absolute Maximum Ratings** (at Ta=25°C)

Characteristics	Symbol	Rating	Unit
VCC Pin Voltage	V _{CC}	V _{SS} - 0.3 to V _{SS} + 25	V
Feedback Pin Voltage	V _{FB}	V _{SS} - 0.3 to V _{CC}	V
ON/OFF Pin Voltage	V _{EN}	V _{SS} - 0.3 to V _{CC} + 0.3	V
Switch Pin Voltage	V _{SW}	V _{SS} - 0.3 to V _{CC} + 0.3	V
Power Dissipation	PD	Internally limited	mW
Storage Temperature Range	T _{ST}	-40 to +150	°C
Operating Junction Temperature	T _{OPJ}	-20 to +125	°C
Junction Temperature Range	T _J	-40 to +150	°C
Operating Supply Voltage	V _{OP}	+4.5 to +23	V
Switching Current	I _{SW}	6.5	A
Thermal Resistance from Junction to case	θ _{JC}	15	°C/W
Thermal Resistance from Junction to ambient	θ _{JA}	40	°C/W

Note : θ_{JA} is measured with the PCB copper area(need connect to Exposed pad) of approximately 1 in²(Multi-layer).

❖ **Electrical Characteristics** (VIN = 12V, Ta=25°C, unless otherwise specified)

Characteristics	Symbol	Conditions	Min	Typ	Max	Units
Feedback Voltage	V _{FB}	I _{OUT} =0.2A	0.784	0.800	0.816	V
Quiescent Current	I _{CCQ}	V _{FB} =1.2V force driver off	-	3	5	mA
Feedback Bias Current	I _{FB}	I _{OUT} =0.2A	-	0.1	0.5	uA
Shutdown Supply Current	I _{SD}	V _{EN} =0V	-	2	10	uA
Line Regulation	ΔV _{OUT} /V _{OUT}	V _{CC} =8V~23V, I _{OUT} =0.3A	-	1	2	%
Load Regulation	ΔV _{OUT} /V _{OUT}	I _{OUT} = 0.1 to 2.5A	-	0.2	0.5	%
OCSET pin bias current	I _{OCSET}		95	110	140	uA
SS pin Current	I _{SS}		-	4.0	-	uA
Oscillation Frequency	F _{OSC}	SW pin	260	330	400	KHz
Short Circuit Frequency	F _{OSC1}	V _{FB} =0V	-	80	-	KHz
EN Pin Logic input threshold voltage	V _{SH}	High (regulator ON)	2.0	-	-	V
	V _{SL}	Low (regulator OFF)	-	-	0.8	
EN Pin Input Current	I _{SH}	V _{EN} =2.5V (ON)	-	20	-	uA
	I _{SL}	V _{EN} =0.3V (OFF)	-	-10	-	uA
Internal MOSFET R _{DSON}	R _{D kg SON}	V _{CC} =5V, V _{FB} =0V	-	70	100	mΩ
		V _{CC} =12V, V _{FB} =0V	-	45	70	

❖ Electrical Characteristics (Cont.)

Characteristics	Symbol	Conditions	Min	Typ	Max	Units	
Efficiency	EFFI	V _{OUT} = 5V	I _{OUT} = 3A	-	92	-	%
			I _{OUT} = 5A	-	91	-	
Thermal shutdown Temp	TSD		-	135	-	°C	

❖ Application Circuit

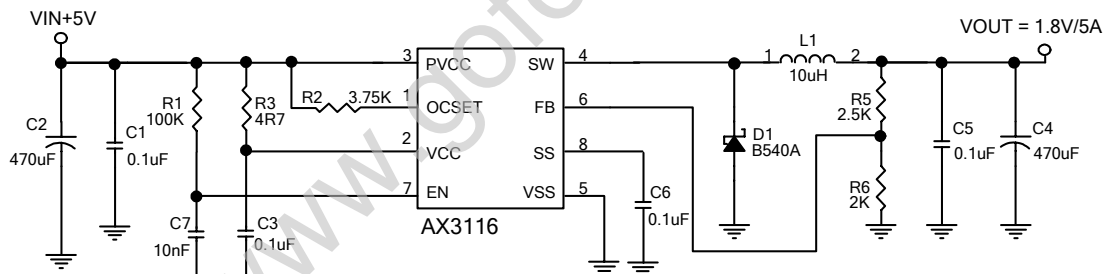
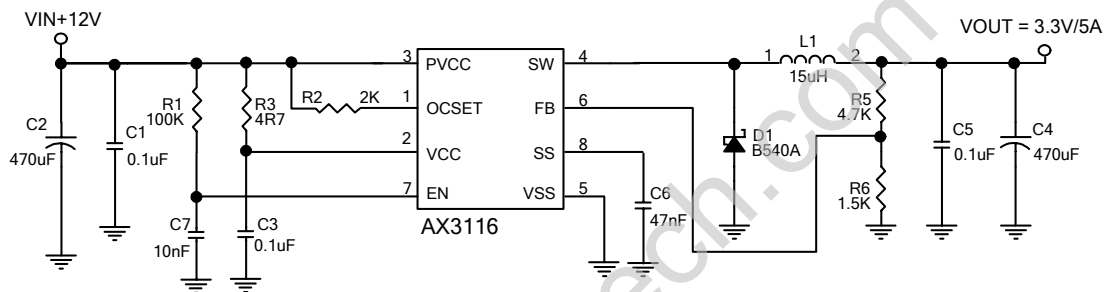

$$V_{OUT} = V_{FB} \times \left(1 + \frac{R_5}{R_6}\right)$$

V_{FB} = 0.8V ; R₄ suggest 0.8K ~ 4k

L1 recommend value (V _{IN} =12V ,I _{OUT} =5A,)				
V _{OUT}	1.8 V	2.5V	3.3V	5V
L1	10uH	10uH	15uH	15uH

❖ Function Descriptions

PWM Control

The AX3116 consists of DC/DC converters that employ a pulse-width modulation (PWM) system. In converters of the AX3116, the pulse width varies in a range from 0 to 100%, according to the load current. The ripple voltage produced by the switching can easily be removed through a filter because the switching frequency remains constant. Therefore, these converters provide a low-ripple power over broad ranges of input voltage and load current.

Setting the Output Voltage

Application circuit item shows the basic application circuit with adjustable output version. The external resistor sets the output voltage according to the following equation:

$$V_{OUT} = 0.8V \times \left(1 + \frac{R5}{R6}\right)$$

Table 1 Resistor select for output voltage setting

V _{OUT}	R6	R5
5V	1.3K	6.8K
3.3V	1.5K	4.7K
2.5V	2.2K	4.7K
1.8V	2K	2.5K
1.5V	2.2K	2.0K
1.2V	3K	1.5K
1.0V	3K	0.75K

RDS (ON) Current Limiting

The current limit threshold is setting by the external resistor (R2) connecting from V_{CC} supply to OCSET pin. The internal 110uA sink current crossing the resistor sets the voltage at pin of OCSET. When the PWM voltage is less than the voltage at OCSET, an over-current condition is triggered. Please refer to the formula for setting the current limit value:

$$I_{SW(MIN)} = \frac{I_{OCSET} \times R2 + 0.05}{R_{DS(ON)}}$$

(Normally, The I_{SW(MAX)} setting more than I_{OUT} 1.0A).

Example:

$$I_{SW} = (110u \times 2K + 0.05) / 45m = 6.67A \quad (V_{in}=12V)$$

$$I_{SW} = (110u \times 3.75K + 0.05) / 70m = 6.6A \quad (V_{in}=5V) \quad (T_a=25^\circ C)$$

Inductor Selection

For most designs, the operating inductor range is 10μH to 15μH. The inductor value can be derived from the following equation:

$$L = \frac{V_{OUT} \times (V_{IN} - V_{OUT})}{V_{IN} \times \Delta I_L \times f_{OSC}}$$

Where is inductor Ripple Current. Large value inductors lower ripple current and small value inductors result in high ripple currents. Choose inductor ripple current approximately 15% of the maximum load current 5A, $\Delta I_L = 0.75A$. The DC current rating of the inductor should be at least equal to the maximum load current plus half the ripple current to prevent core saturation (5A+0.38A).

Input Capacitor

The input current to the step-down converter is discontinuous, and so a capacitor is required to supply the AC current to the step-down converter while maintaining the DC input voltage. A low-ESR capacitor is required to keep the noise at the IC to a minimum. The low-ESR electrolytic capacitor may also suffice. The input capacitor value should be greater than 470μF. However since it absorbs the input switching current it requires an adequate ripple current rating. Its RMS current rating should be greater than approximately 1/2 of the DC load current. For insuring stable operation CIN should be placed as close to the IC as possible. Alternately a smaller high quality ceramic 0.1uF capacitor may be placed closer to the IC and a larger capacitor placed further away. If using this technique, it is recommended that the larger capacitor be a electrolytic type.

Output Capacitor

The output capacitor is required to maintain the DC output voltage. Low ESR capacitors are preferred to keep the output voltage ripple low. The characteristics of the output capacitor also affect the stability of the regulation control system. The low-ESR electrolytic capacitors are recommended. The output capacitor value should be greater than 470μF.



❖ Typical Characteristics

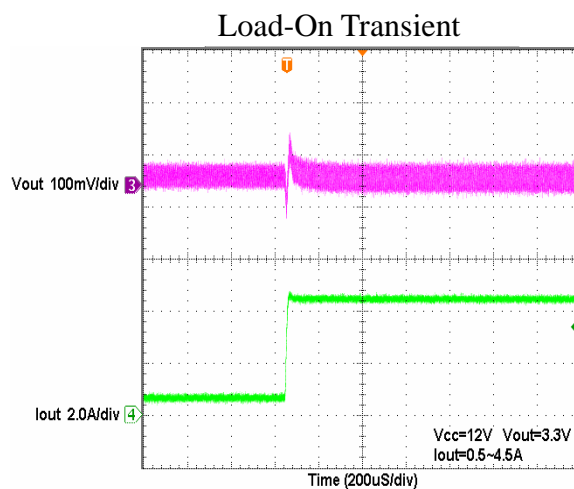
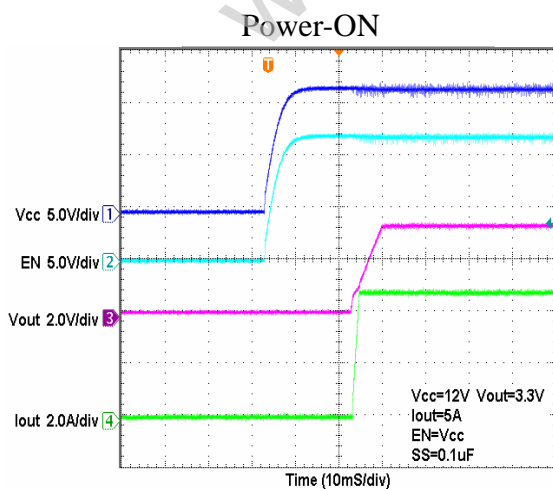
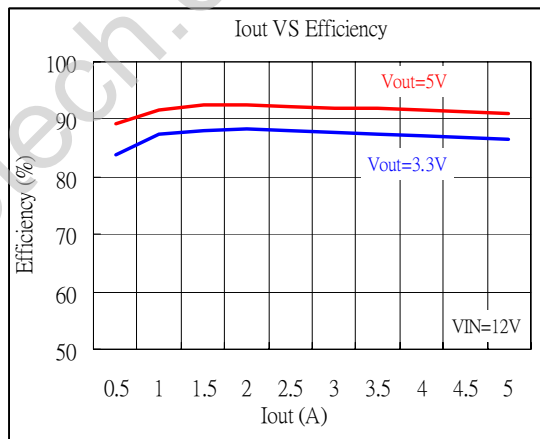
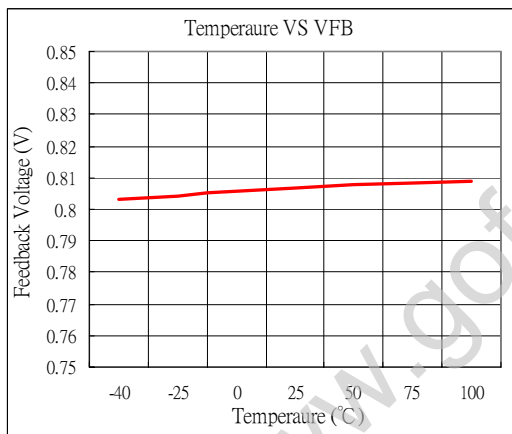
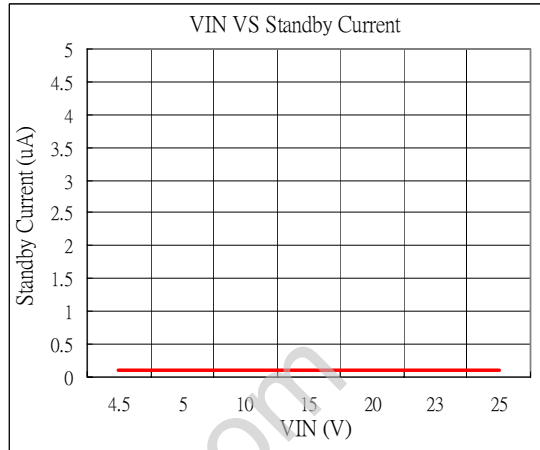
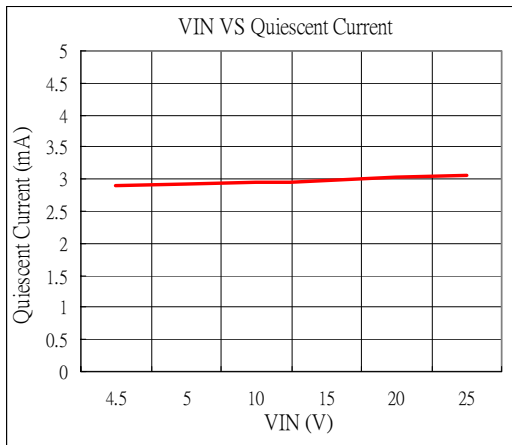

❖ Package Outlines

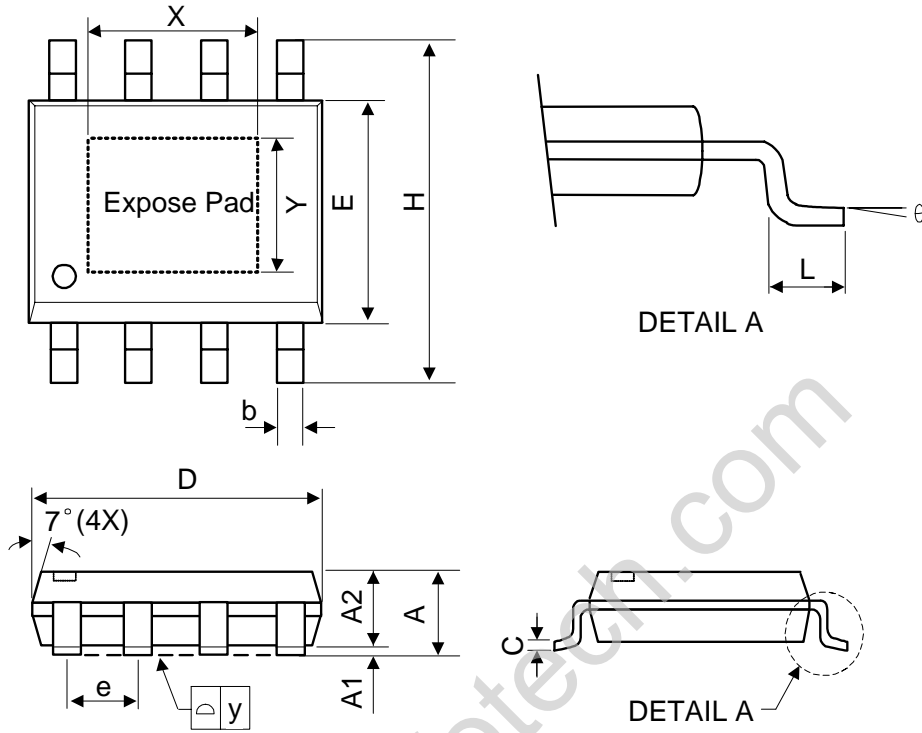

Symbol	Dimensions In Millimeters			Dimensions In Inches		
	Min.	Nom.	Max.	Min.	Nom.	Max.
A	1.40	1.60	1.75	0.055	0.063	0.069
A1	0.10	-	0.25	0.040	-	0.100
A2	1.30	1.45	1.50	0.051	0.057	0.059
C	0.19	0.20	0.25	0.0075	0.008	0.010
D	4.80	4.90	5.00	0.189	0.193	0.197
E	3.80	3.90	4.00	0.150	0.154	0.157
H	5.79	5.99	6.20	0.228	0.236	0.244
L	0.38	0.71	1.27	0.015	0.028	0.050
b	0.33	0.41	0.51	0.013	0.016	0.020
e	1.27 TYP			0.050 TYP		
y	-	-	0.10	-	-	0.004
X	-	2.34	-	-	0.092	-
Y	-	2.34	-	-	0.092	-
θ	0°	-	8°	0°	-	8°