

BM34063A

DC-DC CONVERTER

Features

- 3V to +37V Input Voltage Operation
- Internal 1.6A Peak Current Switch
- Internal $\pm 1.8\%$ Reference
- Low Quiescent Current at 1.6mA
- Frequency from 100Hz ~ 180KHz(100PF)
- Output Voltage Adjustable
- Active Current Limiting
- Step-Up, Step-Down or Inverting Switching Regulators

Description

The BM34063A Series is a monolithic control circuit containing the primary functions required for DC-to-DC converters. These devices consist of an internal temperature compensated reference, comparator, controlled duty cycle oscillator with an active current limit circuit, driver and high current output switch.

Pin Assignment

DIP/SOP-8		Pin1: Switch Collector (SWC)	Pin5: Comparator Inverting Input (FB)
1	SWC	Pin2: Switch Emitter (SWE)	Pin6: Voltage Supply (Vcc)
2	SWE	Pin3: Timing Capacitor (TC)	Pin7: Ipk Sense (Ipk)
3	TC	Pin4: Ground (GND)	Pin8: Voltage Driver Collector (DRC)
4	GND		
	DRC		
	Ipk		
	VCC		
	FB		
	8		
	7		
	6		
	5		

Ordering Information

Part Number	Package
BM34063AGP	DIP-8
BM34063AGS	SOP-8

G means : Pb-free , BM34063AG meets SGS testing standard.

**If one day , you feel not good to AP1513 / MP9141 on price due to cost problem,
you can choose BM34063A as +12V down to 3.3V/5.0V if less than 1A ouput.**

BM34063A

DC-DC CONVERTER

Absolute Maximum Ratings

(Ta=25°C, Unless Otherwise Specified)

Parameter	Symbol	Value	Unit
Power Supply Voltage	V _{CC}	40	V
Comparator Input Voltage Range	V _{ir}	-0.3~+40	V
Switch Collector Voltage	V _{C(SW)}	40	V
Switch Emitter Voltage	V _{SWE}	40	V
Switch Emitter to Collector Voltage	V _{CE}	40	V
Driver Collector Voltage	V _{C(DR)}	40	V
Switch Current	I _{SW}	1.5	A
Power Dissipation at Ta=25°C	P _D	DIP-8	1
		SO-8	0.625
Operating Ambient Temperature Range	T _{opr}	0~+70	°C
Storage Temperature Range	T _{stg}	-65~+150	°C
Operating Junction Temperature	T _{opj}	120	°C
Thermal Resistance Junction-ambient	θJA	125	°C/W

Block Diagram

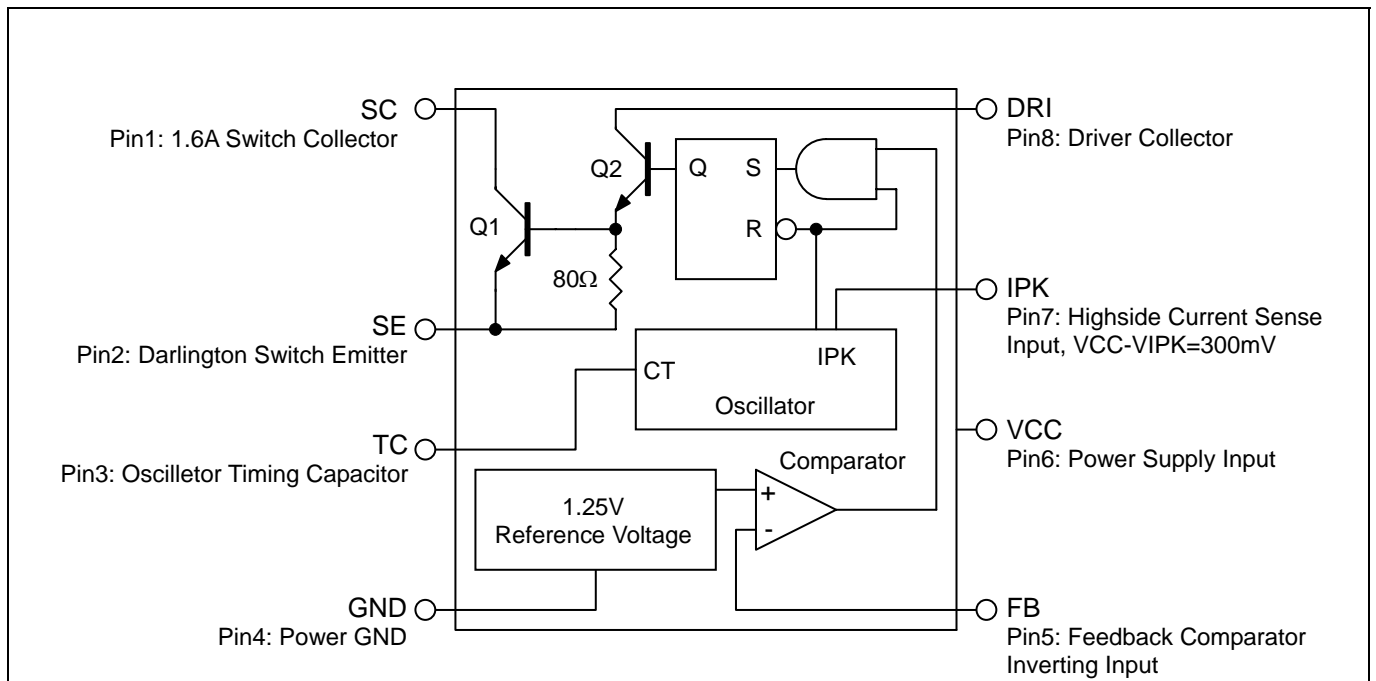

BM34063A

DC-DC CONVERTER

Electrical Characteristics (V_{CC}=5V, Ta=0~70°C, unless otherwise specified)

Parameter	Symbol	Test Condition	Min.	Typ.	Max.	Unit
<i>Oscillator</i>						
Charging Current	I _{chg}	V _{CC} =5~40V, Ta=25°C	10	25	40	uA
Discharge Current	I _{dischg}	V _{CC} =5~40V, Ta=25°C	140	190	240	uA
Frequency	f _{OSC}	V _{PIN5} =0, C _T =1nF, Ta=25°C	20	33	50	KHz
Discharge to Charge Current Ratio	I _{dischg} /I _{chg}	V _{PIN7} =V _{CC} , Ta=25°C	5.2	6	7.5	
Current Limit Sense Voltage	V _{IPK}	I _{dischg} =I _{chg} , Ta=25°C	250	300	350	mV
<i>Output Switch</i>						
Saturation Voltage, Darlington Connection	V _{CE(sat) 1}	I _{SW} =1A, V _{C(SW)} =V _{C(DR)}	-	1	1.3	V
Saturation Voltage	V _{CE(sat) 2}	I _{SW} =1A, I _{C(DR)} =50mA	-	0.4	0.7	V
DC Current Gain	h _{FE}	I _{SW} =1A, V _{CE} =5V	35	120	-	
Collector Off-State Current	I _{CC(off)}	V _{CE} =40V, Ta=25°C	-	10	100	uA
<i>Comparator</i>						
Threshold Voltage	V _{FB}		1.23	1.25	1.27	V
Threshold Voltage Line Regulation	ΔV _{FB}	V _{CC} =5~40V	-	1.5	6	mV
Input Bias Current	I _{IB}	V _{IN} =0V	-	40	400	nA
<i>Total Device</i>						
Supply Current	I _{CC}	V _{CC} =5~40V, V _{PIN7} =V _{CC} , V _{PIN5} >V _{FB} , C _T =0.001uF, Pin7=GND, Remaining pins open	-	1.6	3	mA

Application Information

Design Formula Table

Calculation	Step-Down	Step-Up	Voltage-Inverting
t _{on} /t _{off}	(V _{out} +V _F)/(V _{in(min)} -V _{sat} -V _{out})	(V _{out} +V _F -V _{in(min)})/(V _{in(min)} -V _{sat})	(V _{out} +V _F)/(V _{in(max)} -V _{sat})
(t _{on} +t _{off}) max	1/F _{min}	1/F _{min}	1/F _{min}
C _T	4*10 ⁻⁵ t _{on}	4*10 ⁻⁵ t _{on}	4*10 ⁻⁵ t _{on}
I _{C(sw)}	2*I _{out(max)}	2*I _{out(max)} (t _{on} +t _{off} /t _{off})	2*I _{out(max)} (t _{on} +t _{off} /t _{off})
R _S	0.3/I _{C(sw)}	0.3/I _{C(sw)}	0.3/I _{C(sw)}
L _(min)	(V _{in(min)} -V _{sat} /I _{pk(sw)})*t _{on(max)}	(V _{in(min)} -V _{sat} /I _{pk(sw)})*t _{on(max)}	(V _{in(min)} -V _{sat} /I _{pk(sw)})*t _{on(max)}
C _O	(I _{pk(sw)} *(t _{on} +t _{off}))/(8*V _{ripple(P-P)})	I _{out} *t _{on} /V _{ripple(P-P)}	I _{out} *t _{on} /V _{ripple(P-P)}

V_{sat}: Saturation voltage of the output switch.

V_F: Forward voltage drop of the ringback rectifier.

The following power supply characteristics must be chosen:

V_{in}: Nominal input voltage.

V_{out}: Desired output voltage. |V_{out}|=1.25*(1+RB/RA)

I_{out}: Desired output current

F_{min}: Minimum desired output switching frequency at the selected values for V_{in} and I_{out}.

V_{ripple(P-P)}: Desired peak to peak output ripple voltage in practice, the calculated value will need to be increased due to the capacitor equivalent series resistance and board layout. The ripple voltage should be kept to a low value since it will directly effect the line and load regulation.

BM34063A

DC-DC CONVERTER

Application Information (Continued)

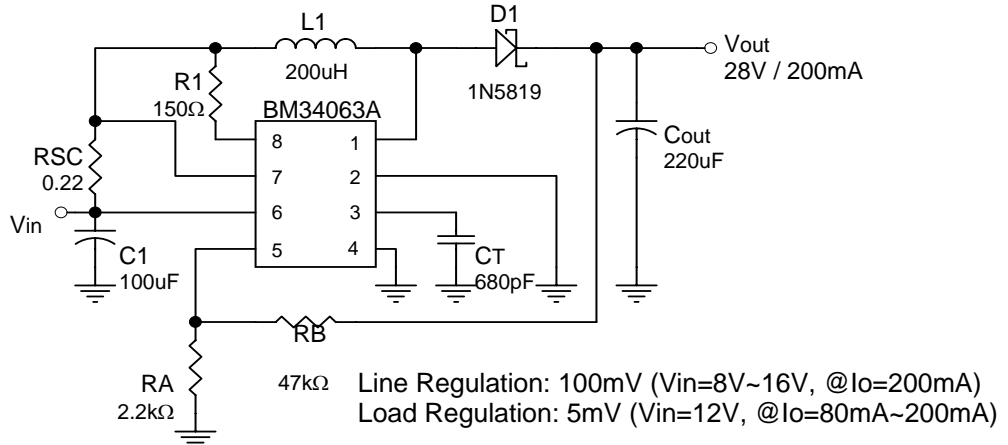

Fig.2 Step-Up Converter

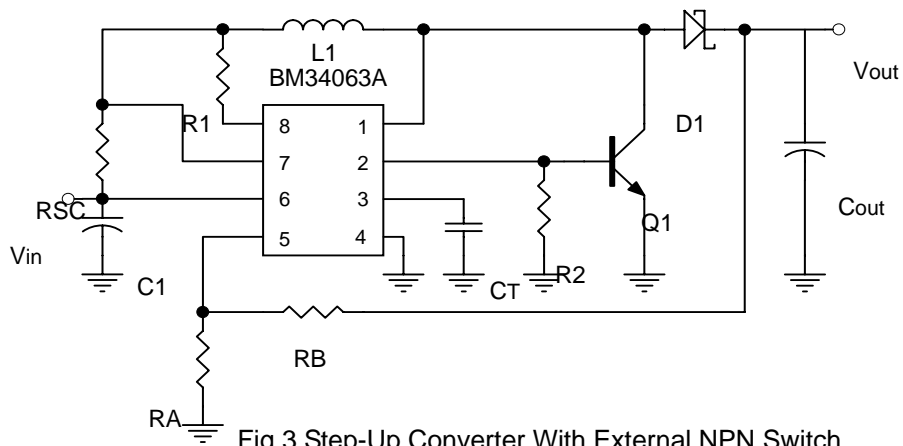

Fig.3 Step-Up Converter With External NPN Switch

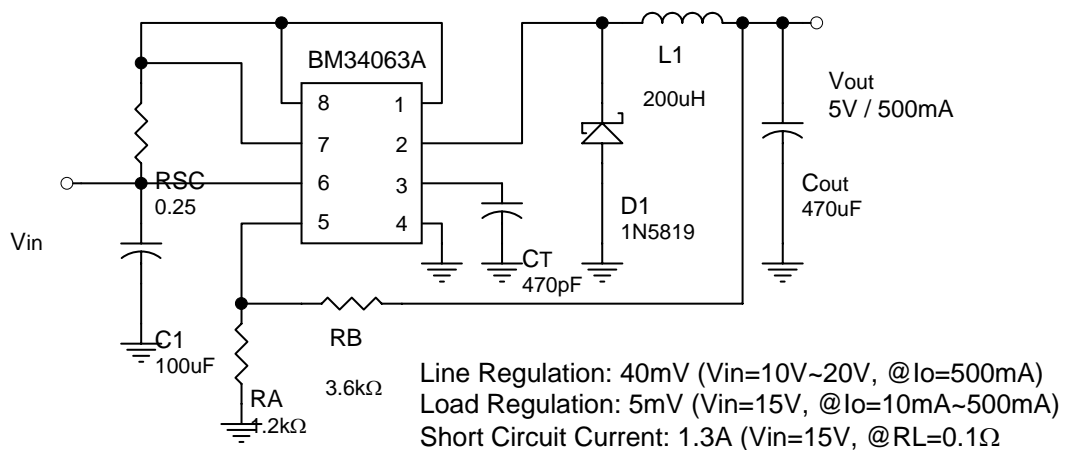

Fig.4 Step-Down Converter

BM34063A

DC-DC CONVERTER

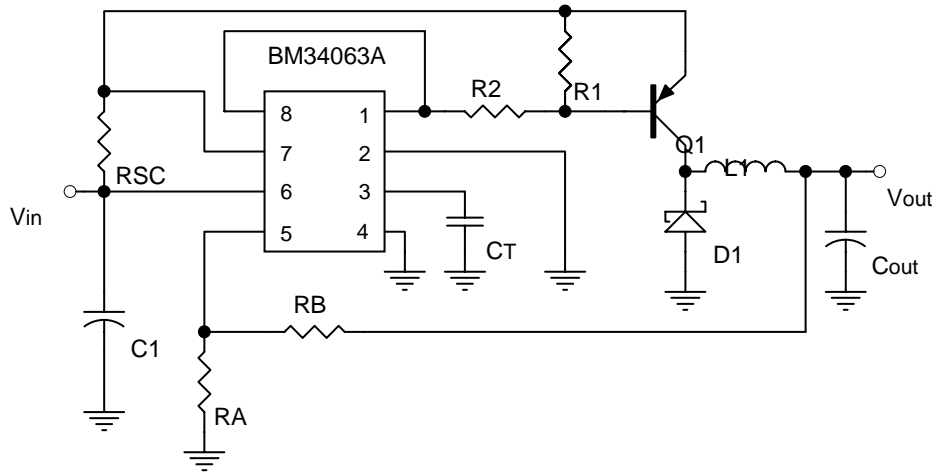

Fig.5 Step-Down Converter With External PNP Saturation Switch

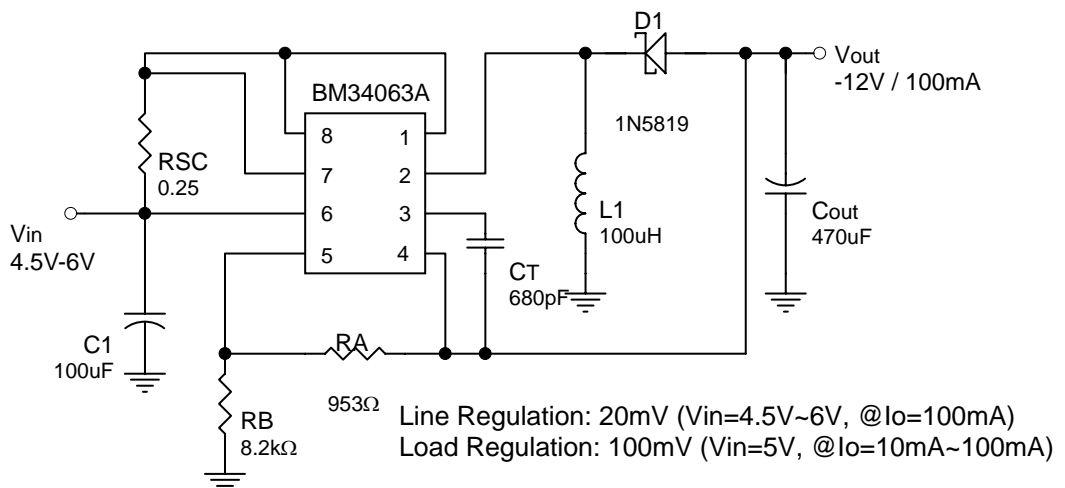

Fig.6 Voltage Inverting Converter

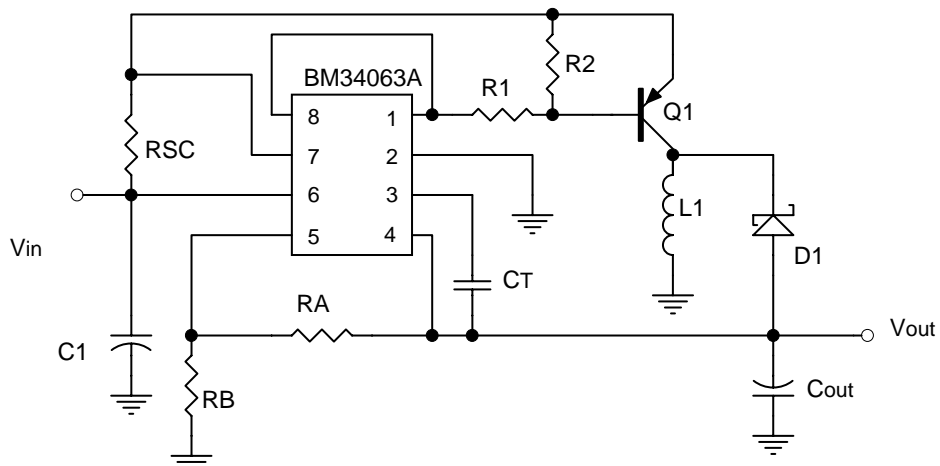
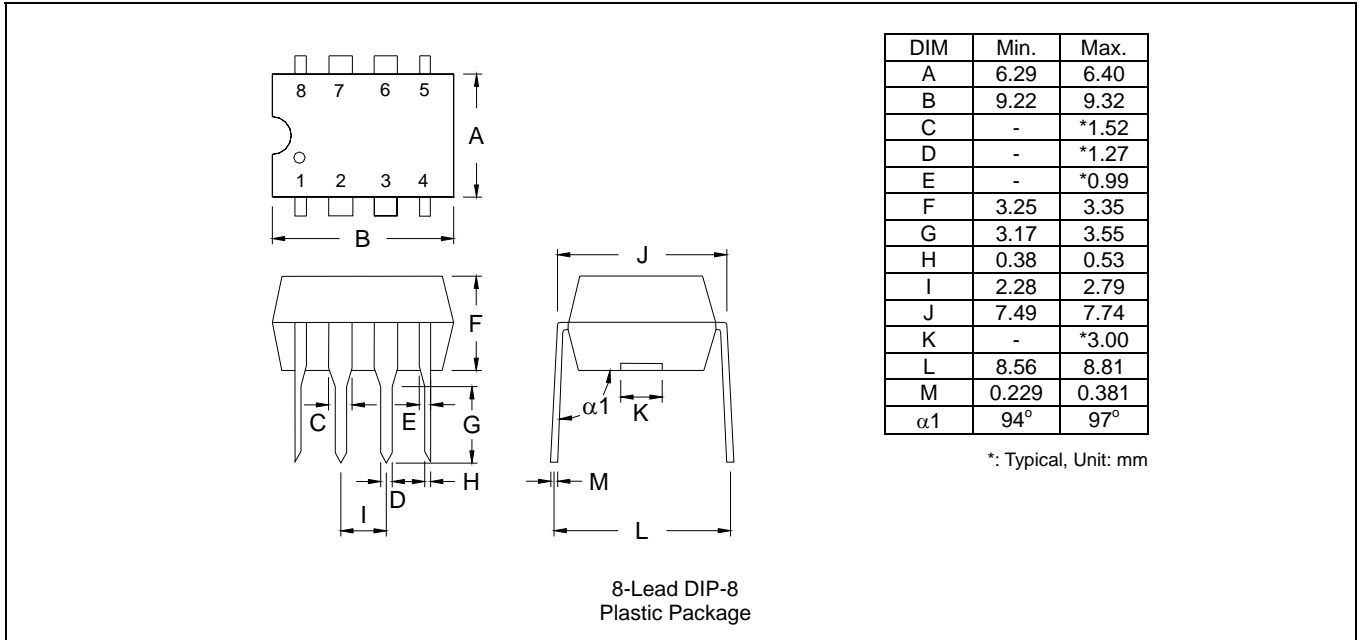

Fig.7 Voltage Inverting Converter With External PNP Saturation Switch

BM34063A

DC-DC CONVERTER

DIP-8 (P) Dimension



SOP-8 (S) Dimension

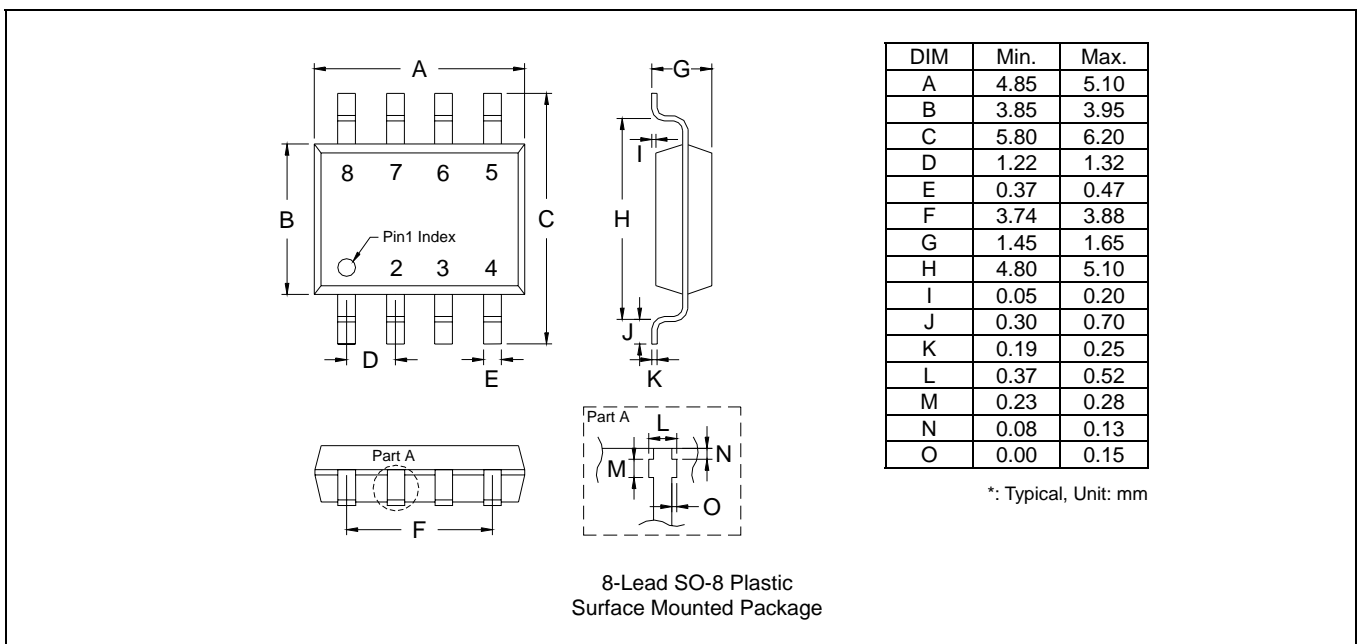

Soldering Methods

1. Storage environment: Temperature=10°C~35°C Humidity=65%±15%
2. Reflow soldering of surface-mount devices

Figure 1: Temperature profile

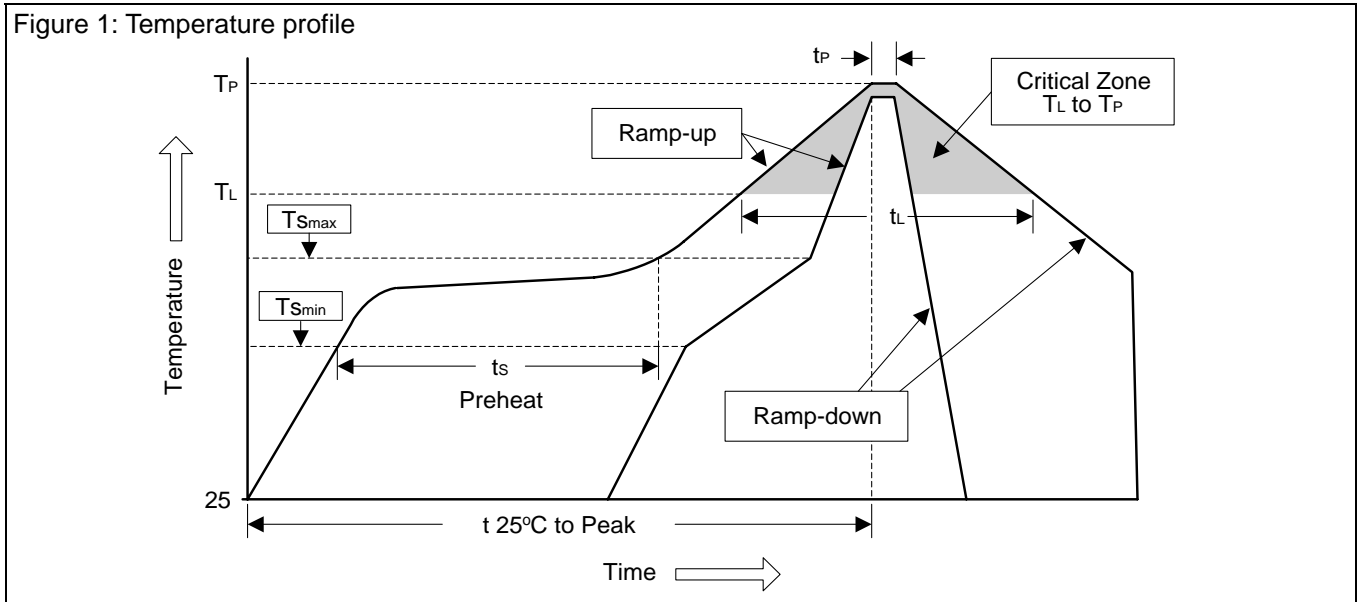

Profile Feature	Sn-Pb Eutectic Assembly	Pb-Free Assembly
Average ramp-up rate (T_L to T_P)	<3°C/sec	<3°C/sec
Preheat		
- Temperature Min (T_{Smin})	100°C	150°C
- Temperature Max (T_{Smax})	150°C	200°C
- Time (min to max) (t_s)	60~120 sec	60~180 sec
T_{Smax} to T_L		
- Ramp-up Rate	<3°C/sec	<3°C/sec
Time maintained above:		
- Temperature (T_L)	183°C	217°C
- Time (t_L)	60~150 sec	60~150 sec
Peak Temperature (T_P)	240°C +0/-5°C	260°C +0/-5°C
Time within 5°C of actual Peak Temperature (t_P)	10~30 sec	20~40 sec
Ramp-down Rate	<6°C/sec	<6°C/sec
Time 25°C to Peak Temperature	<6 minutes	<8 minutes

3. Flow (wave) soldering (solder dipping)

Products	Peak temperature	Dipping time
Pb devices.	245°C ±5°C	5sec ±1sec
Pb-Free devices.	260°C +0/-5°C	5sec ±1sec