



---

**Advanced Linear Charge Management  
Controllers****Features**

- Preset Charge Voltage with  $\pm 1\%$  Accuracy
- Input Voltage:  $>8.9V$
- Ideal for Dual-Cell (8.4V) Li-Ion Batteries
- Pre-Charging, the Charge Current is adjustable
- Constant -Current Charging, the Charge Current is adjustable
- Constant-Voltage Charging
- Constant-Current/Constant-Voltage Charging with Temperature Monitoring
- Automatic Recharge
- Double LEDs Charge Status Indication
- Available in SOP-8L Package

**Applications**

- Charger for Li-Ion Coin Cell Batteries
- Portable MP3 Players, Wireless Headsets
- Bluetooth Applications
- Multifunction Wristwatches

**Description**

The SC6038 is a highly advanced complete constant-current/ constant voltage linear charger for cell lithium-ion batteries. Its package and low external component count make the SC6038 ideally suited for portable applications. The charge current can be programmed externally with a single resistor, which may be programmed up to 1A. SC6038 determines the charge mode by detecting the battery voltage: Pre-charge, constant current charging, constant voltage charging. The charge current of Pre-charging and constant -current charging is adjustable. The SC6038 is monitored by temperature monitor during the constant-current and constant-voltage charging. There are two LEDs indicate the charge mode.

The SC6038 charger converters are available in the SOP-8L packages (or upon request).

Typical Application

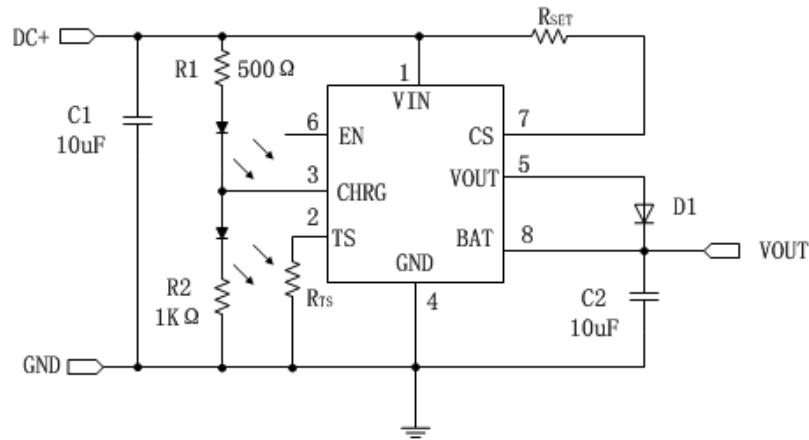
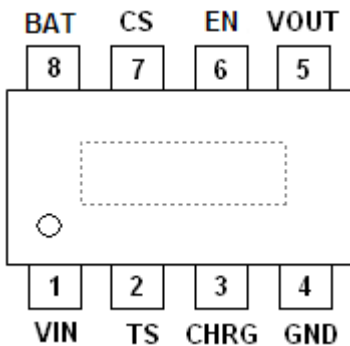

Figure 1

Pin Assignment



**SOP-8L**

PIN NUMBER SOP-8L	PIN NAME	DESCRIPTION
1	VIN	Positive Input Supply Voltage.
2	TS	Temperature Sense
3	CHRG	Open-Drain Charge Status Output
4	GND	Ground
5	VOUT	Charge Current Output
6	EN	ON/OFF Control (High Enable)
7	CS	Charge Current Program
8	BAT	Battery Connection

Absolute Maximum Ratings

- Input Supply Voltage (VIN) ..... -0.3V to 18V
- TS、CHRG、CS ..... - 0.3V to VIN + 0.3V
- Maximum Junction Temperature ..... 125°C
- Operating Ambient Temperature Range..... -40°C to 85°C
- Storage Temperature Range ..... -65 °Cto 125°C
- Lead Temperature (Soldering, 10 sec)..... 300°C

**Electrical Characteristics**Operating Conditions:  $T_A=25^{\circ}\text{C}$ .

SYMBOL	PARAMETER	CONDITIONS	MIN	TYP	MAX	UNITS
$I_{VIN}$	Input Supply Current		0.15	0.7	1.1	mA
$I_{SLEEP}$	VIN Sleep Current	VIN=7V VOUT=8V			7.8	$\mu\text{A}$
$I_{IV(VOUT)}$	Input bias current on VOUT pin	VOUT=8.4V	10		65	$\mu\text{A}$
<b>Battery Voltage Regulation Constant-current Charge</b>						
$V_{O(REG)}$	Output voltage		8.317	8.4	8.484	V
$V_{(CS)}$	Current regulation threshold	Voltage at pin CS , relative to VIN	180	200	220	mV
<b>Precharge Comparator</b>						
$V_{(min)}$	Precharge threshold		5.6	6	6.2	V
<b>Precharge Current Regulation</b>						
$I_{(PRECHG)}$	Precharge current regulation	Voltage at pin CS, relative to VIN, $R_{SET}=1\Omega$ .		18		mA
		Voltage at pin CS, relative to VIN, $R_{SET}=1\Omega$ , VIN=9V	10		35	mA
<b><math>V_{RCH}</math> comparator (Battery Recharge Threshold)</b>						
$V_{(RCH)}$	Recharge threshold			$V_{O(REG)} - 400\text{mV}$		V
<b>CHRG Pin</b>						
$V_{OL(CHRG)}$	Output (low) voltage	$I_{OL}=10\text{mA}$		1.5		V
$V_{OH(CHRG)}$	Output (high) voltage	$I_{OH}=5\text{mA}$	VIN-2			V



## Application Information

### Functional Description

The SC6038 is an advanced 1A linear charge controller for single or two-cell Li-Ion or Li-Pol applications. Refer to Blocking Diagram (Figure 2) and Operation Flow Chart (Figure 3) in this section.

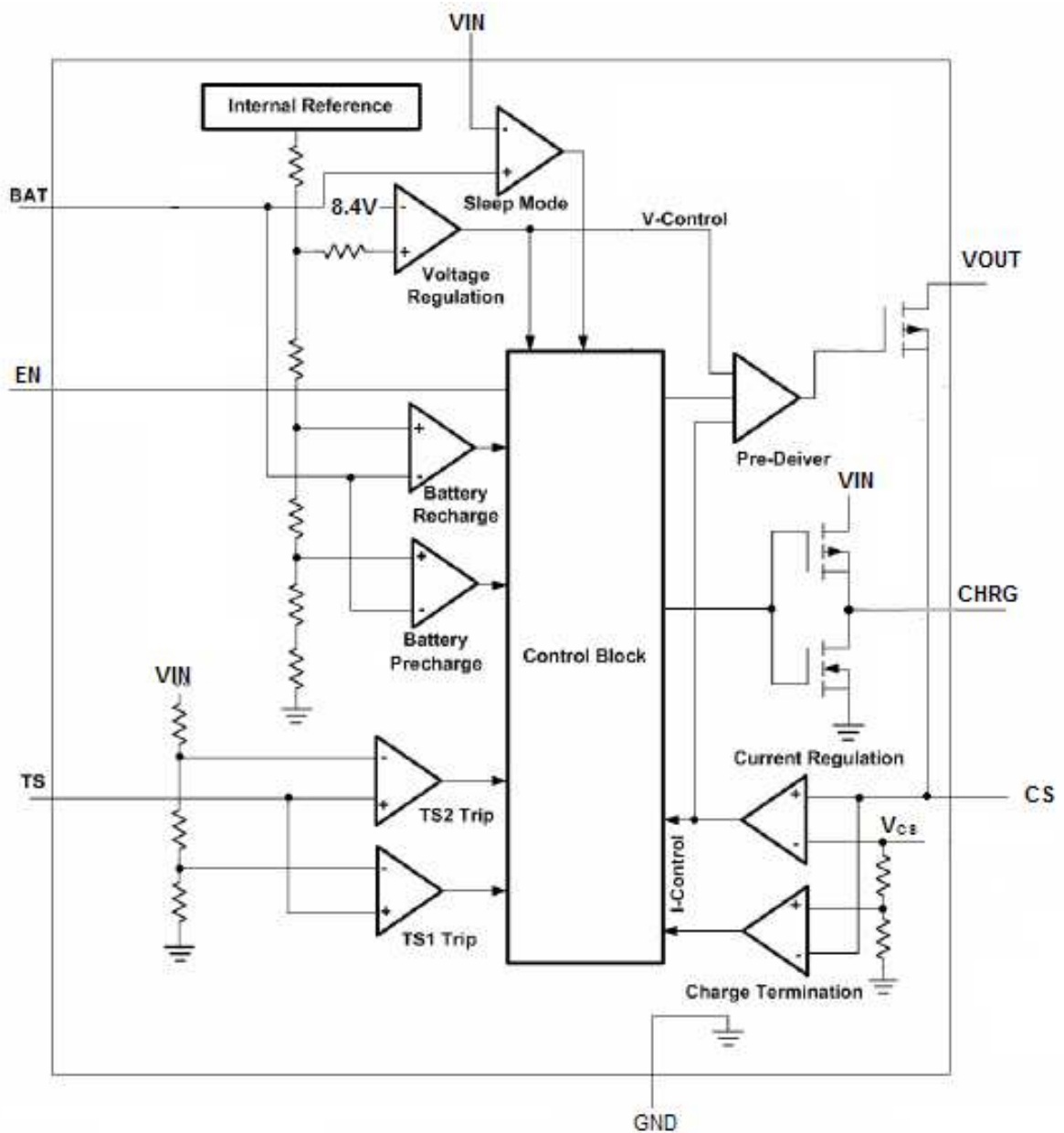

Figure 2: Blocking Diagram

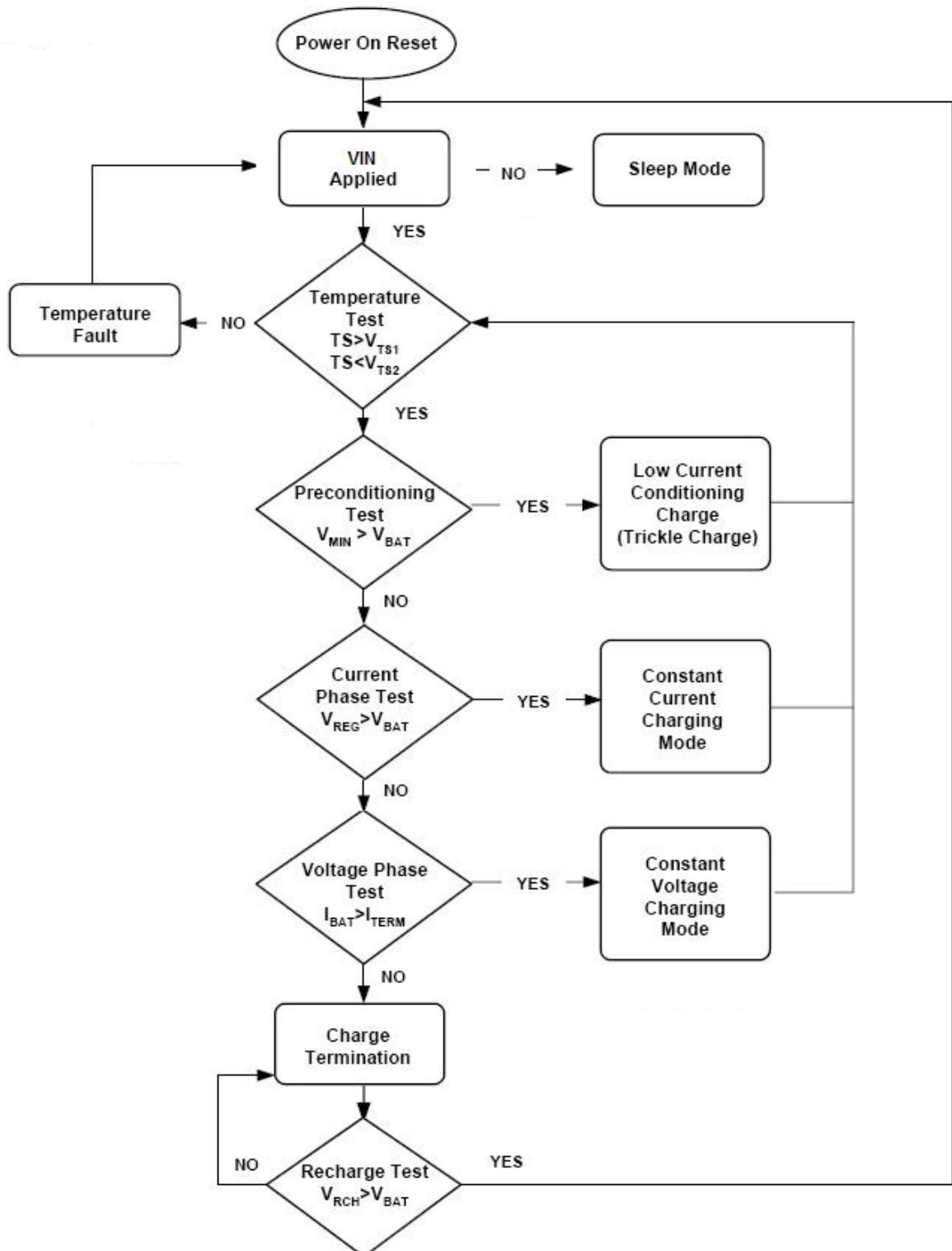

Figure 3: Operation Flow Chart



Qualification and Precharge

When power is applied, the SC6038 starts a charge-cycle if a battery is already present or when a battery is inserted. Charge qualification is based on battery temperature and voltage.

The SC6038 suspends charge if the battery temperature is outside the  $V_{TS1}$  to  $V_{TS2}$  range and suspends charge until the battery temperature is within the allowed range. The SC6038 also checks the battery voltage. If the battery voltage is below the precharge threshold  $V_{(min)}$ , the SC6038 uses precharge to condition the battery. The conditioning charge rate  $I_{(PRECHG)}$  is set at approximately 10% of the regulation current. The conditioning current also minimizes heat dissipation in the external pass-element during the initial stage of charge. See Figure 4 for a typical charge-profile.

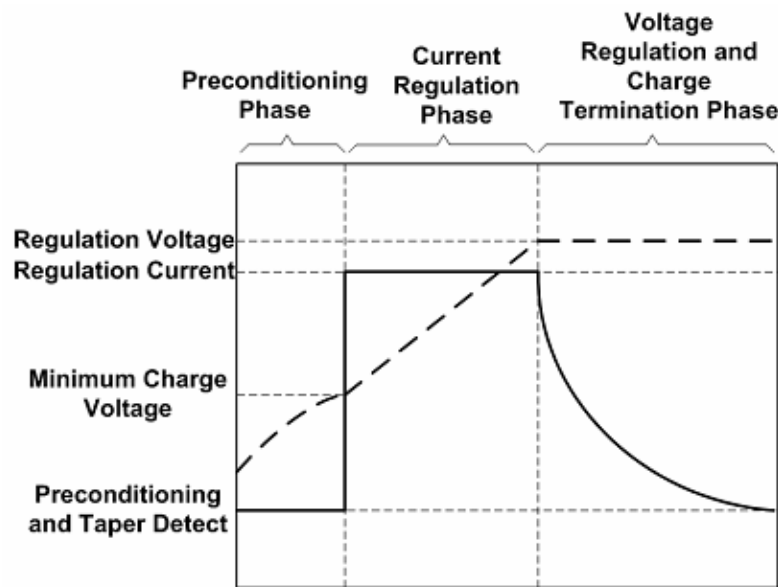

Figure 4: Typical Charge Profile

Current Regulation Phase

The SC6038 regulates current while the battery-pack voltage is less than the regulation voltage,  $V_{O(REG)}$ . The SC6038 monitors charge current at the CS input by the voltage drop across a sense-resistor,  $R_{SET}$ , in series with the battery pack. In current sensing configuration,  $R_{SET}$  is between the VIN and CS pins, charge-current feedback, applied through pin CS, maintains a voltage of  $V_{CS}$  across the current sense resistor. The following formula calculates the value of the Sense resistor:

$$R_{SET} = \frac{V_{CS}}{I_{REG}}$$

Where  $I_{REG}$  is the desired charging current.

Voltage Phase

The voltage regulation feedback is through the BAT pin. This input is tied directly to the positive side of the battery pack. The SC6038 monitors the battery-pack voltage between the BAT and GND pins. The SC6038 is offered 8.4V output voltage.



**Charge Termination Recharge**

The SC6038 monitors the charging current during the voltage-regulation phase. The SC6038 declares a done condition and terminates charge when the current drops to the charge termination threshold,  $I_{TERM}$ . A new charge cycle begins when the battery voltage falls below the  $V_{RCH}$  threshold.

**Battery Temperature Monitoring**

The SC6038 continuously monitors temperature by measuring the voltage between the TS and GND pin. An internal current source provides the bias for most common 10-kΩ negative-temperature coefficient thermistors. The SC6038 compares this voltage against its internal  $V_{TS1}$  and  $V_{TS2}$  thresholds to determine if charging is allowed (See Figure 5). The temperature sensing circuit is immune to any fluctuation in  $V_{IN}$ , since both the external voltage divider and the internal thresholds  $V_{TS1}$  and  $V_{TS2}$  are referenced to  $V_{IN}$ .

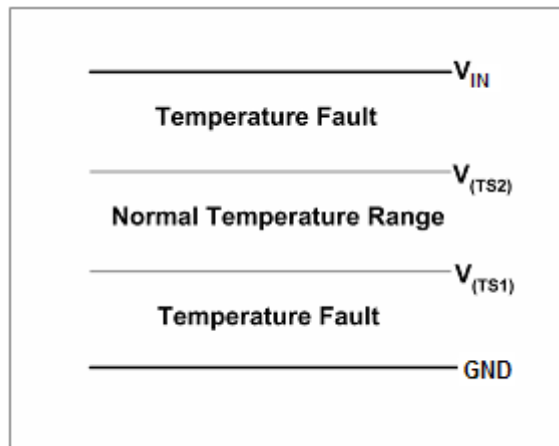

**Figure 5: TS Input Thresholds**

**Charge Status Indication**

The SC6038 reports the status of the charge on the 3-state CHRG pin. The following table summarized the operation of the CHRG pin.

Condition	CHRG pin
Battery conditioning and charging	High
Charge complete(done)	Low
Temperature fault or sleep mode	Hi-Z

The STAT pin can be used to drive a dual- chip LEDs.



### **Low-Power Sleep Mode**

When the input supply is disconnected, the charger automatically enters power-saving sleep mode. This feature prevents draining the battery pack during the absence of VIN.

### **Selecting Input Capacitor**

In most applications, all that is high-frequency decoupling capacitor. The SC6038 works with both regulated and unregulated external dc supplies. If a non-regulated supply is chosen, the supply voltage to the minimum required input voltage at maximum load. If not, more capacitance must be added to the input of the charger.

### **Selecting Output Capacitor**

The SC6038 does not require any output capacitor for loop stability.

In order to maintain good AC stability in constant Voltage mode, a minimum capacitance of 10uF is recommended to bypass the BAT pin to GND. This capacitance provides compensation when there is no battery load. In addition, the battery and interconnections appear inductive at high frequencies. These elements are in the control feedback loop during Constant Voltage mode. Therefore, the bypass capacitance may be necessary to compensate for the inductive nature of the battery pack.

Virtually any good quality output filter capacitor can be used, independent of the capacitor's minimum ESR (Effective Series Resistance) value. The actual value of the capacitor and its associated ESR depends on the forward transconductance (gm) and capacitance of the external pass transistor. A 10uF tantalum or aluminum electrolytic capacitor at the output is usually sufficient to ensure stability for up to a 1A output current.

### **Reverse Blocking Protection**

The reverse-blocking protection diode, depicted in Figure1 provides protection from a faulted or shorted input, or from a reversed-polarity input source. Without the protection diode, a faulted or shorted input would discharge the battery pack through the body diode of the external pass transistor.

If a reverse-protection diode is incorporated in the design, it should be chosen to handle the fast charge current continuously at the maximum ambient temperature. In addition, the reverse-leakage current of the diode should be kept as small as possible.





## Application Information

### PIN ASSIGNMENT

VIN (Pin 1): Positive Input Supply Voltage. It Provides power to the charger VIN and should be bypassed with a 10uF capacitor.

TS (Pin 2): Temperature Sense.

CHRG (Pin 3): Charge Status Indication. When the battery is charging, the CHRG pin is pulled low. When the charge cycle is completed or reverse battery lockout / No AC is detected, CHRG is forced high impedance.

GND (Pin 4): Ground.

VOOUT (Pin 5): Charge Current Output. It should be bypassed with at least a 10uF capacitor. It provides charge current to the battery and regulates the final float voltage to 8.4V.

EN (Pin 6): En Control Input. Forcing this pin above 1.5V enables the part. Forcing this pin below 0.4V shuts down the device. In shutdown, all functions are disabled drawing <1uA supply current. Do not leave EN floating.

CS (Pin 7): Charge Current Program, Charge Current Monitor and Shutdown Pin. The charge current is programmed by connecting a resistor,  $R_{ISET}$ .

BAT (Pin 8): Battery Connection.



### Packaging Information

#### SOP-8 Package Outline Dimension

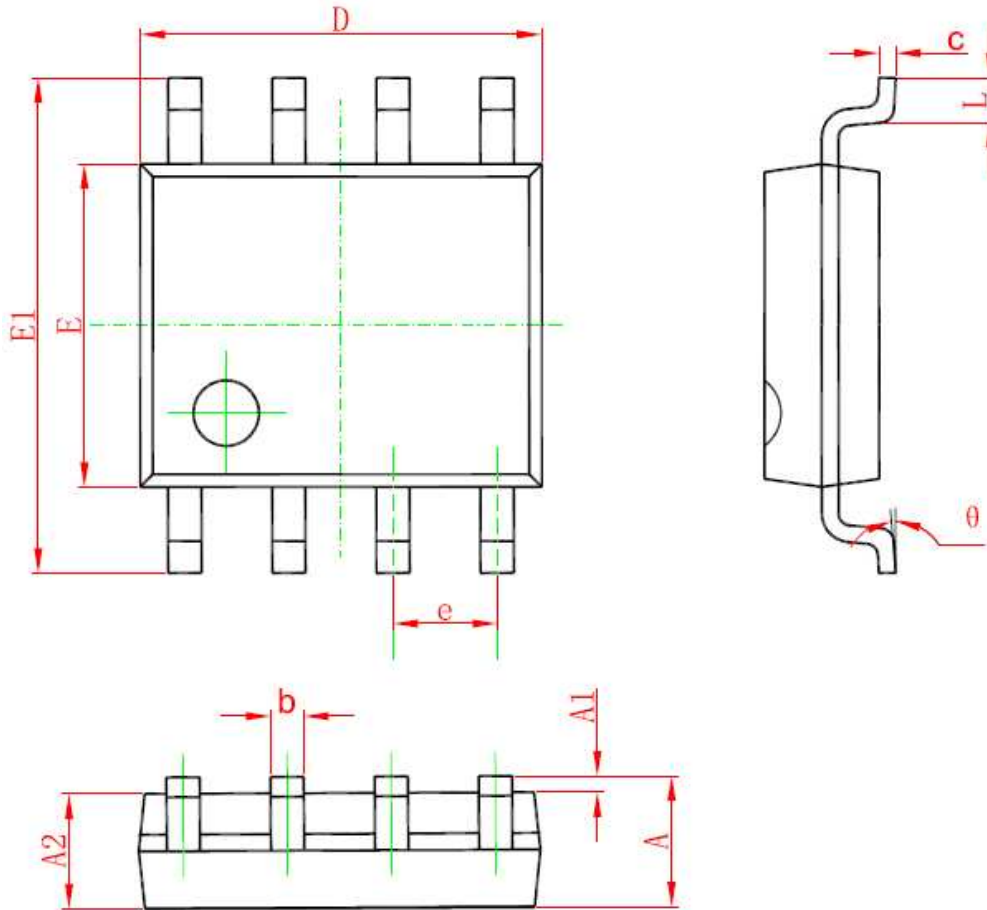

Symbol	Dimensions In Millimeters		Dimensions In Inches	
	Min	Max	Min	Max
A	1.350	1.750	0.053	0.069
A1	0.100	0.250	0.004	0.010
A2	1.350	1.550	0.053	0.061
b	0.330	0.510	0.013	0.020
c	0.170	0.250	0.006	0.010
D	4.700	5.100	0.185	0.200
E	3.800	4.000	0.150	0.157
E1	5.800	6.200	0.228	0.244
e	1.270(BSC)		0.050(BSC)	
L	0.400	1.270	0.016	0.050
θ	0°	8°	0°	8°

Subject changes without notice