

GENERAL DESCRIPTION

RM622X combines a dedicated current mode PWM controller with a high voltage power MOSFET. It is optimized for high performance, low standby power, and cost effective off-line flyback converter applications in sub 20W range.

RM622X offers complete protection coverage with automatic self-recovery feature including Cycle-by-Cycle current limiting, over load protection, VDD over voltage clamp and under voltage lockout. Excellent EMI performance is achieved with frequency shuffling technique together with soft switching control at the totem pole gate drive output.

The tone energy at below 20kHz is minimized in the design and audio noise is eliminated during operation. RM622X is offered in DIP8 package.

APPLICATIONS

- Offline AC/DC flyback converter for
- ◆ Battery charger
 - ◆ PDA power supplies
 - ◆ Digital cameras and camcorder adaptor
 - ◆ VCR, SVR, STB, DVD & DVCD Player SMPS
 - ◆ Set-Top Box power
 - ◆ Auxiliary power supply for PC and server
 - ◆ Open-frame SMPS

FEATURES

- Power on soft start reducing MOSFET Vds stress.
- Frequency shuffling for EMI
- Extended Burst Mode control for improved efficiency and minimum standby power design
- Audio noise free operation
- Fixed 50KHz switching frequency
- Internal synchronized slope compensation
- Low VDD start-up current and low operating current
- LEB and current sense input
- Good protection coverage with auto self-recovery
 - ◆ VDD over voltage clamp and under voltage lockout with hysteresis
 - ◆ Input compensated Cycle-by-Cycle over-current threshold setting for constant output power limiting over universal input voltage range.
 - ◆ Overload protection
 - ◆ Over voltage protection

TYPICAL APPLICATION

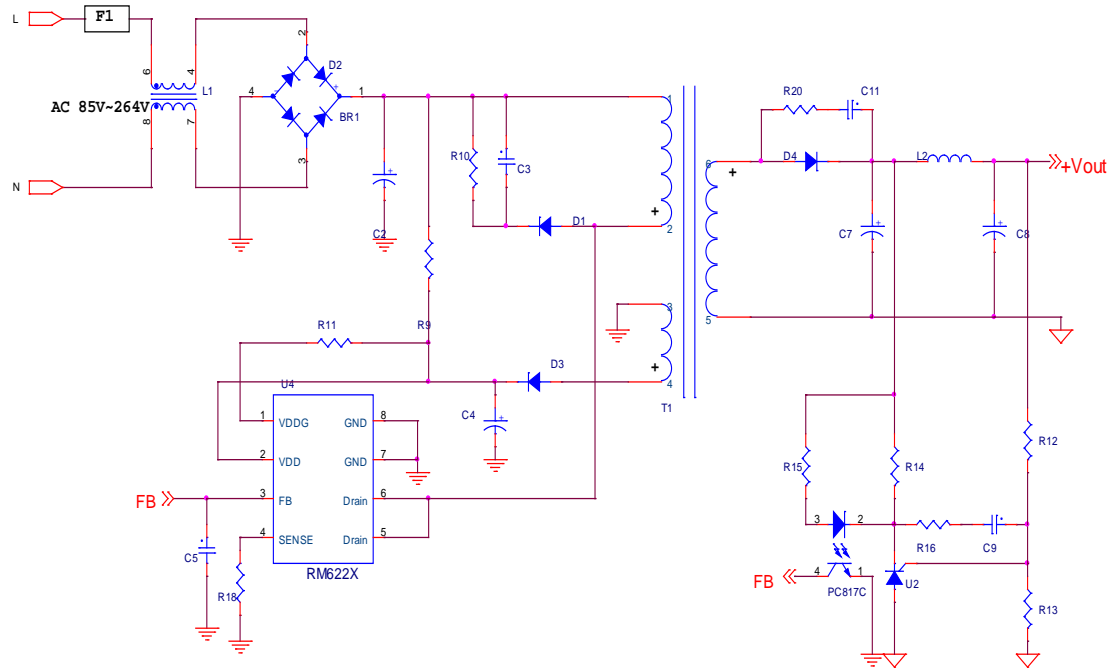

PIN ASSIGNMENT(SOP-8&DIP8)

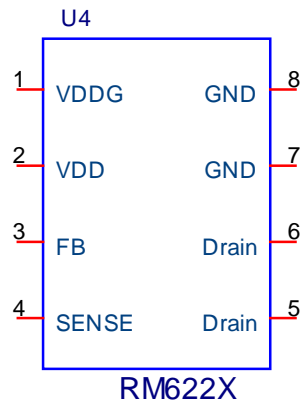

Pin Descriptions

Pin Name	Description
GND	Ground
FB	Feedback input pin.the PWM duty cycle is determined by voltage level into this pin and the current-sense signal at PIN 4
VDD-G	Internal Gate Driver Power Supply
SENSE	Current sense input
VDD	Power supply input
Drain	HV MOSFET Driver Pin,the driver pin is connected to the primary lead of the transformer.

BLOCK DIAGRAM

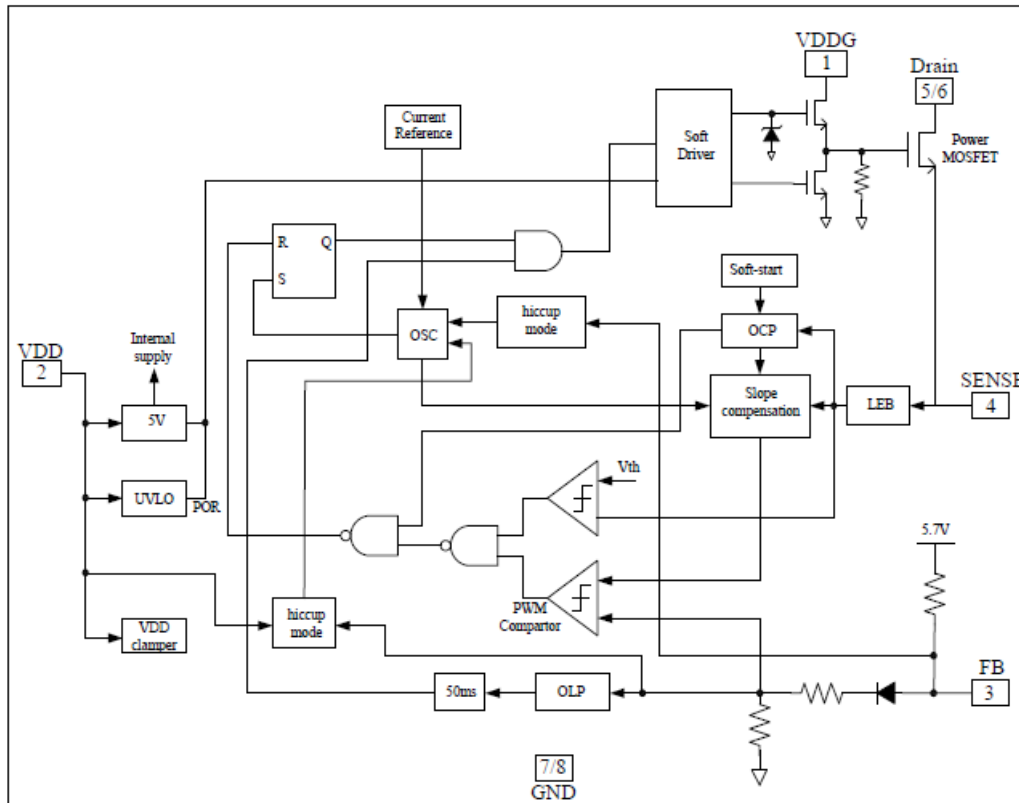

ABSOLUTE MAXIMUM RATINGS

Parameter	Value
Drain Voltage(off state)	-0.3V to 600V
VDD voltage	-0.3V to 30V
VDD-G input voltage	-0.3V to 30V
VDD clamp continous current	10mA
FB input voltage	-0.3V to 7V
Sense input voltage	-0.3V to 7V
Min/Max operating junction temperature T _j	-20°C to150°C
Min/Max storage temperature	-55°C to160°C
Lead temperature(soldering 10sec)	260°C

Note: Stesses beyond those listed under “absolute maximum ratings” may cause permanent damage to the device, Exposure to absolute maximum-rated conditions for extended periods may affect device reliability.

ELECTRICAL CHARACTERISTICS

($T_A = 25^\circ\text{C}$ unless otherwise noted, $V_{DD} = 16\text{V}$)

Symbol	Parameter	Test Conditions	Min	Typ	Max	Unit
Supply Voltage (VDD)						
I_{startup}	VDD Start up Current	$V_{DD}=14.1\text{V}$, Measure Leakage current into VDD		3	20	μA
I_{VDD} (Operation)	Operation Current	$V_{\text{FB}}=3\text{V}$		2		mA
UVLO(ON)	VDD Under Voltage Lockout Enter		8.5	9	9.5	V
UVLO(OFF)	VDD Under Voltage Lockout Exit(Recovery)		14.2	14.8	16	V
OVP(ON)	Over voltage protection voltage	$\text{CS}=0\text{V}$, $\text{FB}=3\text{V}$ Ramp up VDD until gate clock is off	27.0	28.5	30.0	V
VDD_Clamp	VDD Zener clamp Voltage	$I_{\text{DD}}=10\text{mA}$		30		V

Feedback Input Section(FB pin)						
$V_{\text{FB_Open}}$	V_{FB} Open Loop Voltage		5.4	5.6	6.0	V
$I_{\text{FB_Short}}$	FB pin short circuit current	Short FB pin to GND and measure current		1.55		mA
$V_{\text{TH_0D}}$	Zero Duty Cycle FB Threshold Voltage			0.8		V
$V_{\text{TH_PL}}$	Power Limiting FB Threshold Voltage			3.7		V
$T_{\text{D_PL}}$	Power Limiting Debounce Time			50		mS
$Z_{\text{FB_IN}}$	Input Impedance			4		$\text{K}\Omega$
Current Sense Input(Sense Pin)						
Soft start time				4		ms
T_{blanking}	Leading edge blanking time			300		ns

Z _{SENSE_IN}	Input Impedance			40		KΩ
T _{D_OC}	Over Current Detection and Control Delay	From Over Current Occurs till the Gate drive output start to turn off		120		nS
V _{TH_OC}	Internal Current Limiting Threshold Voltage	FB=3.3V	0.76	0.8	0.82	V
Oscillator						
F _{osc}	Normal Oscillation Frequency		45	50	55	KHz
Δf _{Temp}	Frequency Temperature Stability			5		%
Δf _{VDD}	Frequency Voltage Stability			5		%
D _{max}	Maximum duty cycle	FB=3.3V, CS=0V	70	80	90	%
F _{Hiccup}	Hiccup Mode Base Frequency			22		KHz

Power MOSFET Section						
BV _{ds}	MOSFET Drain Source Breakdown Voltage	V _{GS} =0V, I _{DS} =250uA	600			V
R _{DS(on)}	Static Drain to Source On Resistance	V _{GS} =10V, I _{DS} =1A	CR6221T	8.0	9.5	Ω
			CR6224S	5.0	5.8	Ω
			CR6224T	5.0	5.8	Ω
			CR6228T	3.0	3.6	Ω
			CR6229T	2.0	2.5	Ω
Frequency jitting						
Δf _{SOC}	Frequency Modulation range /Base frequency		-4		4	%

Operation Description

The RM622X is a low power off-line SMPS Switcher optimized for off-line flyback converter applications in sub 24W power range. The Hiccup mode control greatly reduces the standby power consumption and helps the design easily to meet the international power conservation requirements.

Startup Current and Start up Control

Startup current of RM622X is designed to be very low so that VDD could be charged up above UVLO threshold level and device starts up quickly. A large value startup resistor can therefore be used to minimize the power loss yet achieve a reliable startup in application. For AC/DC adaptor with universal input range design, a 2 Mohm, 1/8 W startup resistor could be used together with a VDD capacitor to provide a fast startup and yet low power dissipation design solution.

Operation current

The Operation current of RM622X is lower than 2 mA. Good efficiency is achieved with RM622X low operating current together with the 'Advanced Hiccup mode' control features.

Soft Start

RM622X features an internal 4 ms soft start to soften the electrical stress occurring in the power supply during startup. It is activated during the power on sequence. As soon as VDD reaches UVLO(OFF), the peak current is gradually increased from nearly zero to the maximum level. Every restart up is followed by a soft start.

Oscillator Normal Operation

The normal switching frequency of RM622X is internally fixed at 50 KHz. No external frequency setting components are required for PCB design simplification.

Frequency jitting for EMI improvement

The frequency jitter (switching frequency modulation) is implemented in RM622X. The oscillation frequency is modulated so that the tone energy is spread out. The spread spectrum minimizes the conduction band EMI and therefore eases the system design.

Advanced Hiccup Mode Operation

At light load or zero load condition, most of the power dissipation in a switching mode power supply is from switching loss on the MOSFET, the core loss of the transformer and the loss on the snubber circuit. The magnitude of power loss is in proportion to the switching frequency. Lower switching frequency leads to the reduction on the power loss and thus conserves the energy. The switching frequency is internally adjusted at no load or light load condition. The switch frequency reduces at light/no load condition to improve the conversion efficiency. At light load or no load condition, the FB input drops below Hiccup mode threshold level and device enters Hiccup Mode control. The Gate drive output switches only when VDD voltage drops below a preset level and FB input is active to output an on state to minimize the switching loss and reduce the standby power consumption to the greatest extend. The switching frequency control also eliminates the audio noise at any loading conditions.

Current Sensing and Leading Edge Blanking

Cycle-by-Cycle current limiting is offered in RM622X current mode PWM control. The switch current is detected by sense resistor into the sense pin. An internal leading edge blank circuit chops off the sensed voltage spike at initial internal power MOSFET on state due to snubber diode reverse recovery and surge gate current of internal power MOSFET so that the external RC filtering on sense input is no longer needed. The current limiting comparator is disabled and cannot turn off the internal power MOSFET during the Blanking period. The PWM duty cycle is determined by the current sense input voltage and the FB input voltage.

Internal Slope Compensation

Built-in slope compensation circuit adds voltage ramp onto the current sense input voltage for PWM generation. This greatly improves the close loop stability at CCM and prevents the sub-harmonic oscillation and thus reduces the output ripple voltage.

Drive

The internal power MOSFET in RM622X is driven by a dedicated gate driver for power switch control. Too weak the gate drive strength results in higher conduction and switch loss of MOSFET while too strong gate drive results the compromise of EMI. A good trade-off is achieved through the built-in totem pole gate design with right output strength and dead time control. The low idle loss and good EMI system design is easier to achieve with this dedicated control scheme. In addition to the gate drive control scheme mentioned, the gate drive strength can clamp threshold voltage, the internal VDD clamp circuitry will clamp VDD to 30V, and the output of RM622X is shut down also.

also be adjusted externally by a resistor connected between VDD and VDDG, the falling edge of the Drain output can be well controlled. It provides great flexibility for system EMI design.

Protection Controls

Good power supply system reliability is achieved with its rich protection features including Cycle-by-Cycle current limiting (OCP); Over load Protection (OLP); Under Voltage Lockout on VDD (UVLO); Over voltage protection (OVP) and VDD clamp function. The OCP is line voltage compensated to achieve constant output power limit over the universal input voltage range. At overload condition when FB input voltage exceeds power limit threshold value for more than TD_PL, control circuit reacts to shut down the switcher. Switcher restarts when VDD voltage drops below UVLO limit. VDD is supplied by transformer auxiliary winding output. When VDD ramp up to OVP threshold voltage (28.5V), the output of RM622X will be shut down, when VDD drops below UVLO(ON) limit and Switcher enters power on start-up sequence thereafter. When VDD is higher than VDD.

PACKAGE DIMENSIONS

DIP-8

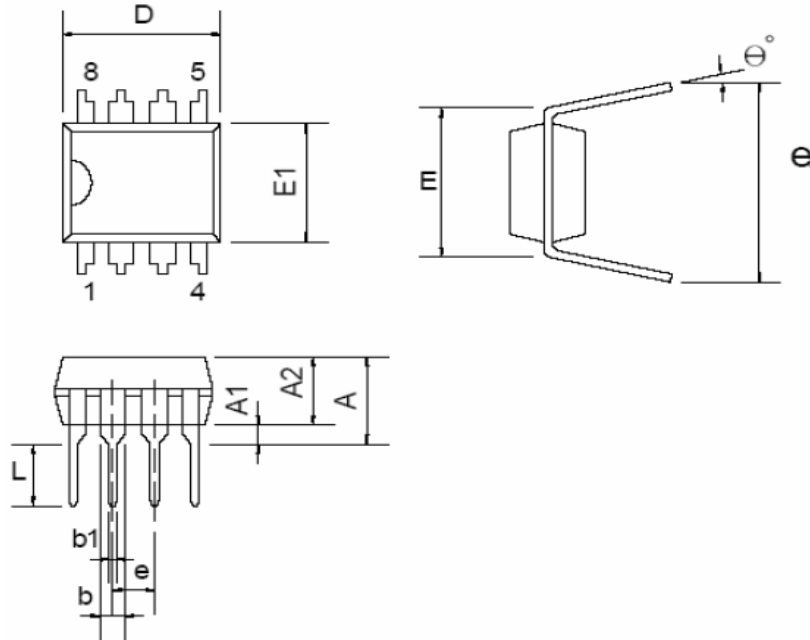

Symbol	Millimeters			Inches		
	Min.	Typ.	Max.	Min.	Typ.	Max.
A			5.334			0.210
A1	0.381			0.015		
A2	3.175	3.302	3.429	0.125	0.130	0.135
b		1.524			0.060	
b1		0.457			0.018	
D	9.017	9.271	10.160	0.355	0.365	0.400
E		7.620			0.300	
E1	6.223	6.350	6.477	0.245	0.250	0.255
e		2.540			0.100	
L	2.921	3.302	3.810	0.115	0.130	0.150
eB	8.509	9.017	9.525	0.335	0.355	0.375
θ°	0°	7°	15°	0°	7°	15°

SOP-8

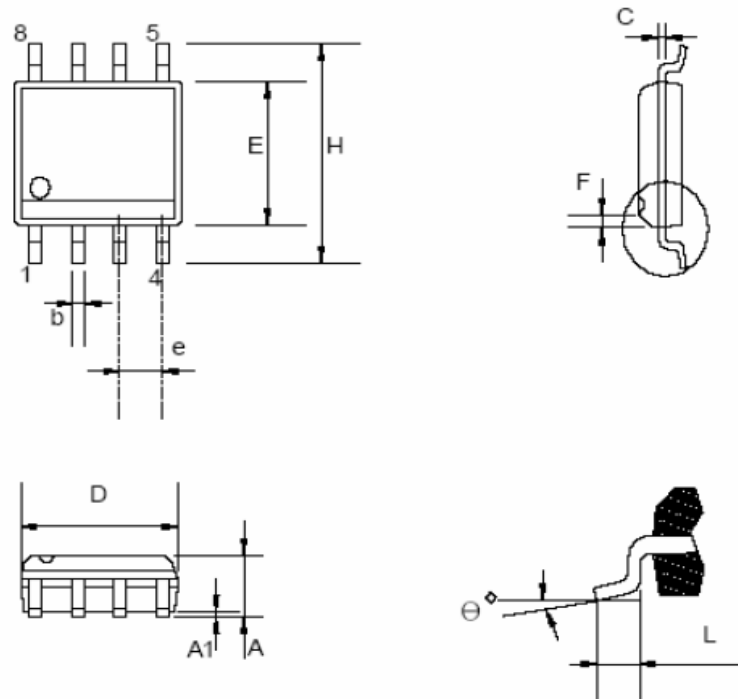

Symbol	Millimeter			Inch		
	Min.	Typ.	Max.	Min.	Typ.	Max.
A	1.346		1.752	0.053		0.069
A1	0.101		0.254	0.004		0.010
b		0.406			0.016	
c		0.203			0.008	
D	4.648		4.978	0.183		0.196
E	3.810		3.987	0.150		0.157
e	1.016	1.270	1.524	0.040	0.050	0.060
F		0.381X45°			0.015X45°	
H	5.791		6.197	0.228		0.244
L	0.406		1.270	0.016		0.050
θ°	0°		8°	0°		8°