

ActivePSR™
Innovative Power!



AC/DC LED Lighting
DESIGN GUIDE

Jan 2011



Table of Contents

ACT364 1W 350mA(3.5V)	3
ACT364 3W 700mA(4V)	5
ACT364 3W 350mA(12V)	7
ACT365 7.8W 350mA(26V) PAR30.....	9
ACT50 5W 350mA(15V)	11
ACT50 5W 128mA(49V)	13
ACT50 7W 350mA(28V)	15
ACT50 12W 350mA(35V) Non-Isolated.....	17
ACT50 12W 350mA(35V) PAR38.....	19
ACT50 12W 350mA(35V) High Efficiency.....	21
ACT50 21W 750mA(28V).....	23

Bill of Materials

REF.	DESCRIPTION	MFTR.
C1	Capacitor, Electrolytic, 4.7μF/400V, 8×12mm	KSC
C2	Capacitor, Ceramic, 100pF/500V, 1206, SMD	POE
C3	Capacitor, Ceramic, 47μF/25V, 1206, SMD	POE
C4	Capacitor, Ceramic, 10μF/10V, 1206, SMD	POE
BD1	Bridge Rectifier, 600V/0.5A, MBS06, SDIP	PANJIT
D1	Diode, Ultra Fast, GS1M, 1000V/1.0A, SMA	PANJIT
D2	General Rectifier, LL4148, 100V/1A	PANJIT
D3	Diode, schottky, 40V/2A, S240, SMA	PANJIT
L1	Axial Inductor, 1.5mH, 0410, Dip	SoKa
PCB1	PCB, L*W*T=25.5×14×1.6mm, Rev:A	Jintong
FR1	Wire Round Resistor, 1W, 10ohm, KNP, 5%	TY-OHM
Q1	Transistor, HFE 15-25, NPN, D13003, TO-92	Huawai
R1	Chip Resistor, 00K ohm, 0805, 5%	TY-OHM
R2	Chip Resistor, 10M ohm, 1206, 5%	TY-OHM
R3,4	Chip Resistor, 22 ohm, 0805, 5%	TY-OHM
R5	Chip Resistor, 52.3K ohm, 0805, 1%	TY-OHM
R6	Chip Resistor, 9.2K ohm, 0805, 1%	TY-OHM
R7	Chip Resistor, 2.8 ohm, 1206, 5%	TY-OHM
R8	Chip Resistor, 3K ohm, 0805, 5%	TY-OHM
T1	Transformer, Lp=4.2mH, EE10	
U1	IC, ACT364US-T, SOT23-6	ACT

PCB Top and Bottom Layers

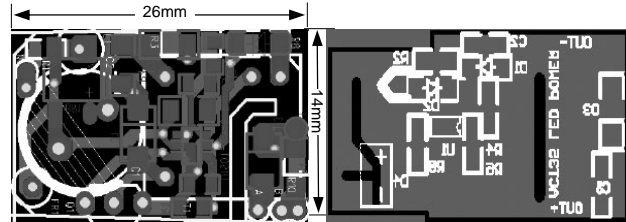

Electrical Specifications

ITEM	DESCRIPTION	CONDITION	LIMITS
1	Electrical Strength	50Hz, 1 minute, from Primary and Secondary	3kVAC
2	P1 Inductance	Inductance between pin 4 and pin 1 at 1VAC & 1kHz	4.2mH ± 7%
3	P1 Leakage Inductance	Inductance between pin 4 and pin 1 with pins 3-2 and 8-5 shorted	75μH

Typical performance Characteristics

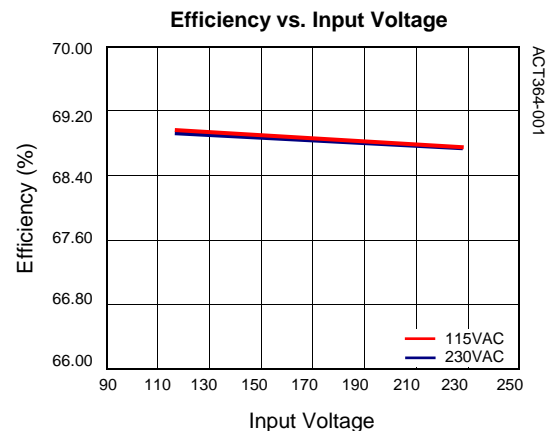

Transformer Specification

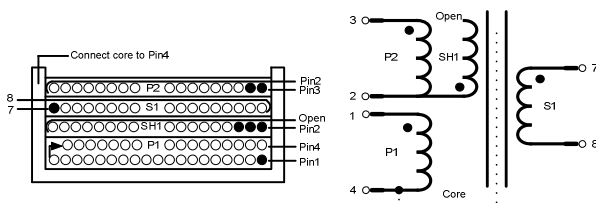

Build Up

WINDING	TERMINAL		TURN S	WIRE			INSULATION	
	START	FINISH		TYPE	SIZE × QTY	LAYER	THICK/WIDE	LAYER
P1	1	4	160	2UEW	0.1Φ×1	3	25μ/8.5mm	2
SH2	2	Open	16	2UEW	0.1Φ×3	1	25μ/8.5mm	2
S1	8	7	10	TEXE Reverse	0.35Φ×1	1	25μ/8.5mm	2
P2	3	2	23	2UEW	0.1Φ×2	2	25μ/8.5mm	2
SH2	Core	4	1	Copper Wire	0.18Φ×1	1	25μ/8.5mm	2

Note: P1 and P2 are Primary, S1 is Secondary (Bobbin: EE-10 Horizontal).

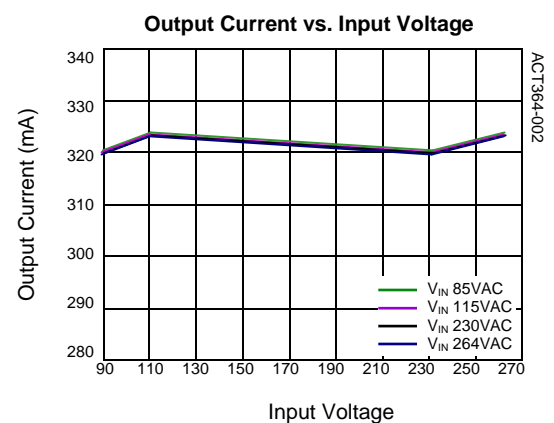

EVALUATION KITS	V _{IN}	I _o	LED(s)
ACT364-LED01	85-264VAC	300-350mA	1 or 2

GU10 1x3W LED Lighting

Input Voltage	Device	LED(s)	Output Voltage	Power Output	Topology
85 - 264VAC	ACT364	1	4V	3W	Flyback



Operation and Application

Figure 1 is the schematic of an offline LED driver using ACT364 to provide a power output of 4V, 650mA. This circuit is a typical flyback type power supply which includes the AC rectified circuit (BD1, L1, C1), primary snubber circuit (D1, R1, C2), power drive circuit (BD pin, Q1), secondary rectified circuit (D3, C4) and the IC control circuit. ACT364 is a Primary Side Regulator (PSR) so that the power supply unit can regulate current and voltage without Opto-couple. Pin 4 and Pin 2 are the VDD and ground pins to provide power for the IC. Pin 3 is the base drive for the NPN transistor. Pin 1 is the switching pin. Pin 5 is the feedback pin that senses the output current and output voltage. Pin 6 is the peak current sense pin. Through a patented PSR

technology, this circuit can provide drivers one 3W LED lights in series due to the wide VDD operation ranges.

Key Component Selection

The turn ratio of the primary turn and the secondary turn (N_p/N_s), together with the R7 sets the maximum output current value as shown in formula (1.1). The voltage setting is through the flyback voltage of auxiliary winding and the feedback resistor R5, R6 as shown in formula (1.2). $N_p/N_s/N_{AUX}$ (168/7/22) must be designed correctly to make sure it operates in DCM mode and it can supply one LEDs in same circuit. A design value V_{OUTCV} equal to 4V and I_{OUTCC_MIN} equal to 650mA are used to do the design.

$$I_{OUTCC} = \frac{1}{2} \times L_P \times \left(\frac{0.396 \times 0.9}{R_{CS}} \right)^2 \times \left(\frac{\eta \times F_{SW}}{V_{OUTCV}} \right) \quad (1.1)$$

N_s and N_{AUX} are numbers of transformer secondary and auxiliary turns, and V_{SEC-R} is the rectifier diode forward drop voltage at approximately 0.1A bias.

$$V_{OUTCV} = V_{REF} \times \left(1 + \frac{R5}{R6} \right) \times \frac{N_s}{N_{AUX}} - V_{SEC_R} \quad (1.2)$$

The peak current limit is set by $(0.396 \times 0.9) / R_{CS}$.

Figure 1:
Typical Application Circuit

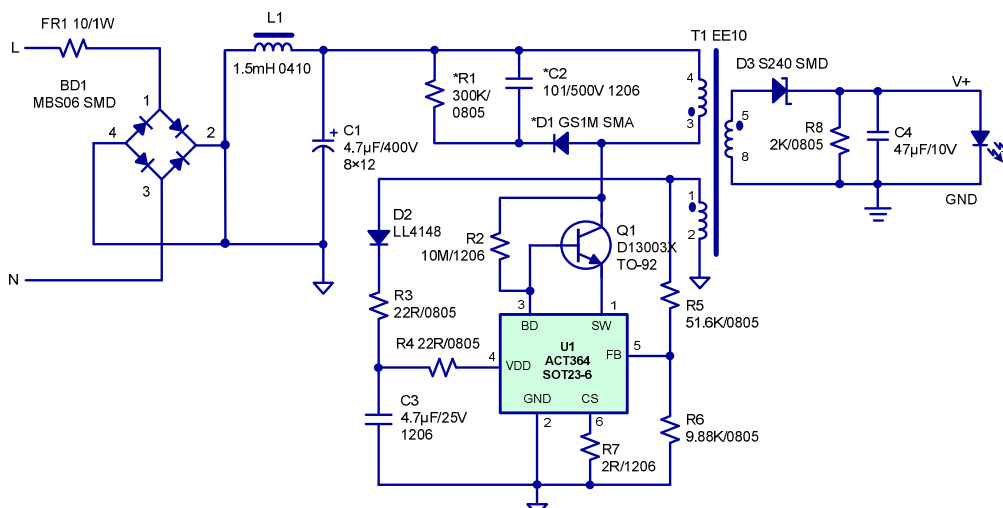

Bill of Materials

REF.	DESCRIPTION	MFTR.
C1	Capacitor, Electrolytic, 4.7μF/400V, 8×12mm	KSC
C2	Capacitor, Ceramic, 100pF/500V, 1206, SMD	POE
C3	Capacitor, Ceramic, 4.7μF/25V, 1206, SMD	POE
C4	Capacitor, Ceramic, 10μF/10V, 1206, SMD	POE
BD1	Bridge Rectifier, 600V/0.5A, MBS06, SDIP	PANJIT
D1	Diode, U1tra Fast, GS1M, 1000V/1.0A, SMA	PANJIT
D2	General Rectifier, LL4148, 100V/1A	PANJIT
D3	Diode, schottky, 40V/2A, S240, SMA	PANJIT
L1	Axial Inductor, 1.5mH, 0410, Dip	SoKa
PCB1	PCB, L*W*T=25.5×14×1.6mm, Rev:A	Jintong
FR1	Wire Round Resistor, 1W, 10ohm, KNP, 5%	TY-OHM
Q1	Transistor, HFE 15-25, NPN, D13003, TO-92	Huawai
R1	Chip Resistor, 300K ohm, 0805, 5%	TY-OHM
R2	Chip Resistor, 10M ohm, 1206, 5%	TY-OHM
R3,4	Chip Resistor, 22 ohm, 0805, 5%	TY-OHM
R5	Chip Resistor, 51.6K ohm, 0805, 1%	TY-OHM
R6	Chip Resistor, 9.88K ohm, 0805, 1%	TY-OHM
R7	Chip Resistor, 2 ohm, 1206, 5%	TY-OHM
R8	Chip Resistor, 2K ohm, 0805, 5%	TY-OHM
T1	Transformer, Lp=3.2mH, EE10	
U1	IC, ACT364US-T, SOT23-6	ACT

Transformer Specification

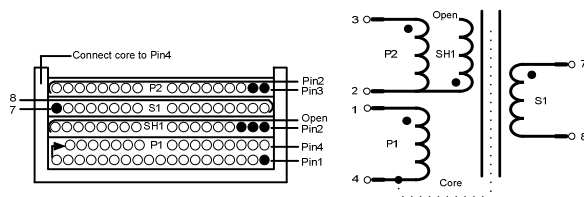

Build up

WINDING	TERMINAL		TURNS	WIRE			INSULATION	
	START	FINISH		TYPE	SIZE × QTY	LAYER	THICK/WIDE	LAYER
P1	1	4	160	2UEW	0.1Φ×1	3	25μ/8.5mm	2
SH2	2	Open	16	2UEW	0.1Φ×3	1	25μ/8.5mm	2
S1	8	7	10	TEXE Reverse	0.35Φ×1	1	25μ/8.5mm	2
P2	3	2	22	2UEW	0.1Φ×2	2	25μ/8.5mm	2
SH2	Core	4	1	Copper Wire	0.18Φ×1	1	25μ/8.5mm	2

P1 and P2 are Primary, S1 is Secondary (Bobbin: EE-10 Vertical)

PCB Top and Bottom Layers

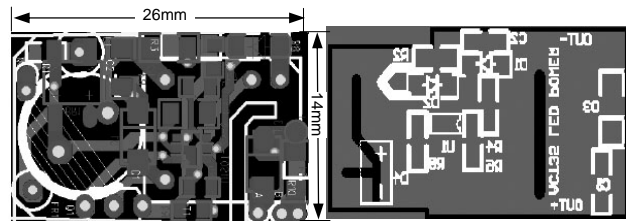

Electrical Specifications

ITEM	DESCRIPTION	CONDITION	LIMITS
1	Electrical Strength	50Hz, 1 minute, from Primary and Secondary	3kVAC
2	P1 Inductance	Inductance between pin 1 and pin 4 at 1VAC & 1kHz	3.2mH ± 7%
3	P1 Leakage Inductance	Inductance between pin 1 and pin 4 with pins 1-2 and 7-8 shorted	75μH

Typical Performance Characteristics

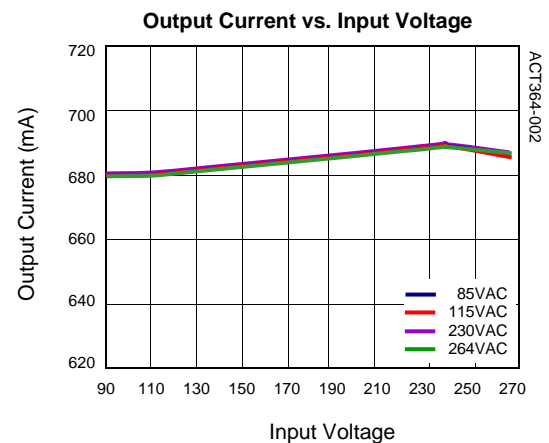
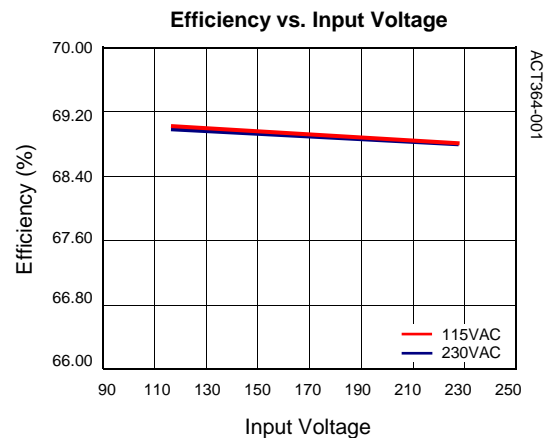

EVALUATION KITS	V _{IN}	I _o	LED(s)
ACT364-LED02	85-264VAC	650-750mA	1

GU10 3x1W LED Lighting

Input Voltage	Device	LED(s)	Output Voltage	Power Output	Topology
85 - 264VAC	ACT364	3	12V	3W	Flyback



Operation and Application

Figure 1 is the schematic of an offline LED driver using ACT364 to provide a power output of 12V, 350mA. This circuit is a typical flyback type power supply which includes the AC rectified circuit (BD1, C1, L1), primary snubber circuit (D1, R1, C2), power drive circuit (BD pin, Q1), secondary rectified circuit (D3, C4) and the IC control circuit. ACT364 is a Primary Side Regulator (PSR) so that the power supply unit can regulate current and voltage without Opto-coupler. Pin 4 and Pin 2 are the VDD and ground pins to provide power for the IC. Pin 3 is the base drive for the NPN transistor. Pin 1 is the switching pin. Pin 5 is the feedback pin that senses the output current and output voltage. Pin 6 is the

peak current sense pin. Through a patented PSR technology, this circuit can provide drivers for two (min), or three (max) LED lights in series due to the wide VDD operation ranges.

Key Component Selection

The turn ratio of the primary turn and the secondary turn (N_p/N_s), together with the R7 sets the maximum output current value as shown in formula (1.1). The voltage setting is through the flyback voltage of auxiliary winding and the feedback resistor R5, R6 as shown in formula (1.2). $N_p/N_s/N_{AUX}$ (160/20/24) must be designed correctly to make sure it operates in DCM mode and it can supply either two or three LEDs in same circuit. A design value V_{OUTCV} equal to 12V and $I_{OUTCC\ MIN}$ equal to 300mA are used to do the design.

$$I_{OUTCC} = \frac{1}{2} \times L_P \times \left(\frac{0.396 \times 0.9}{R_{CS}} \right)^2 \times \left(\frac{\eta \times F_{SW}}{V_{OUTCV}} \right) \quad (1.1)$$

N_s and N_{AUX} are numbers of transformer secondary and auxiliary turns, and $V_{SEC,R}$ is the rectifier diode forward drop voltage at approximately 0.1A bias.

$$V_{OUTCV} = V_{REF} \times \left(1 + \frac{R5}{R6} \right) \times \frac{N_s}{N_{AUX}} - V_{SEC,R} \quad (1.2)$$

The peak current limit is set by $(0.396 \times 0.9)/R_{CS}$.

Figure 1:

Schematic of LED Lighting Driver

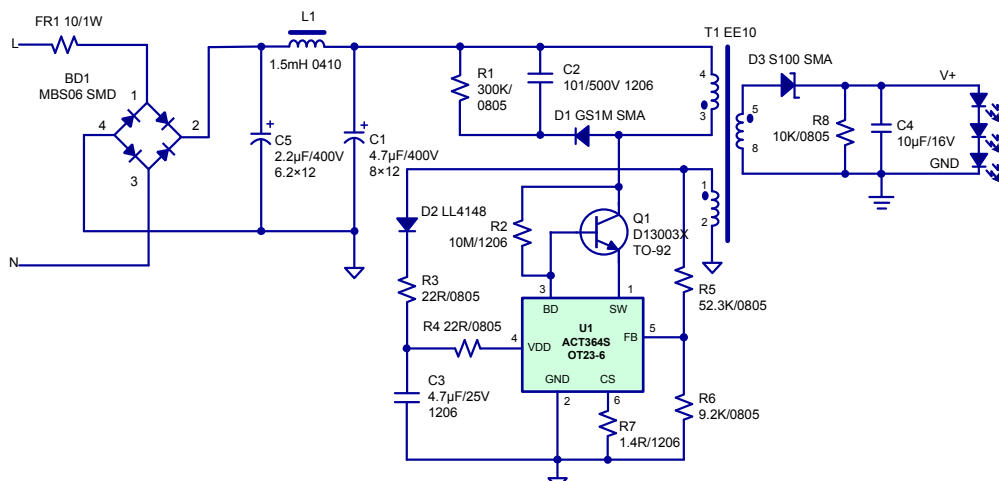

Bill of Materials

REF.	DESCRIPTION	MFTR.
C1	Capacitor, Electrolytic, 4.7µF/400V, 8×12mm	KSC
C2	Capacitor, Ceramic, 100pF/500V, 1206, SMD	POE
C3	Capacitor, Ceramic, 4.7µF/25V, 1206, SMD	POE
C4	Capacitor, Ceramic, 10µF/16V, 1206, SMD	POE
C5	Capacitor, Electrolytic, 2.2µF/400V, 6.2×12mm	KSC
BD1	Bridge Rectifier, 600V/0.5A, MBS06, SDIP	PANJIT
D1	Diode, U1tra Fast, GS1M, 1000V/1.0A, SMA	PANJIT
D2	General Rectifier, LL4148, 100V/1A	PANJIT
D3	Diode, schottky, 100V/1A, S100, SMA	PANJIT
L1	Axial Inductor, 1.5mH, 0410, Dip	SoKa
PCB1	PCB, L*W*T=25.5×14×1.6mm, Rev:A	Jintong
FR1	Wire Round Resistor, 1W, 10ohm, KNP, 5%	TY-OHM
Q1	Transistor, HFE15-25, NPN, D13003, TO-92	Huawai
R1	Chip Resistor, 300K ohm, 0805, 5%	TY-OHM
R2	Chip Resistor, 10M ohm, 1206, 5%	TY-OHM
R3,4	Chip Resistor, 22 ohm, 0805, 5%	TY-OHM
R5	Chip Resistor, 52.3K ohm, 0805, 1%	TY-OHM
R6	Chip Resistor, 9.2K ohm, 0805, 1%	TY-OHM
R7	Chip Resistor, 1.4 ohm, 1206, 5%	TY-OHM
R8	Chip Resistor, 10K ohm, 0805, 5%	TY-OHM
T1	Transformer, Lp=2.1mH, EE10	
U1	IC, ACT364US-T, SOT23-6	ACT

PCB Top and Bottom Layers

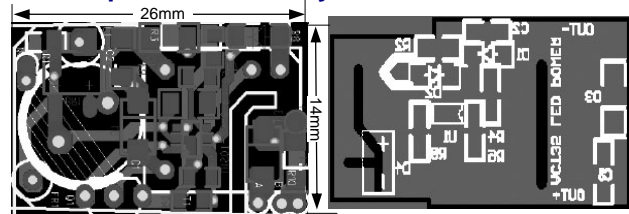

Electrical Specifications

ITEM	DESCRIPTION	CONDITION	LIMITS
1	Electrical Strength	50Hz, 1 minute, from Primary and Secondary	3kVAC
2	P1 Inductance	Inductance between pin 1 and pin 4 at 1VAC & 1kHz	2.1mH ± 7%
3	P1 Leakage Inductance	Inductance between pin 1 and pin 4 with pins 2-3 and 7-8 shorted	75µH

Typical Performance Characteristics

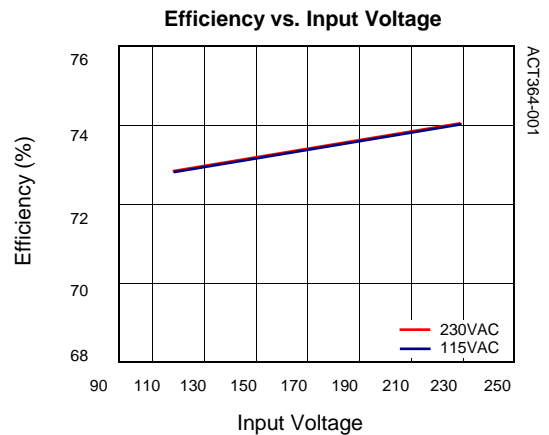

Transformer Specification

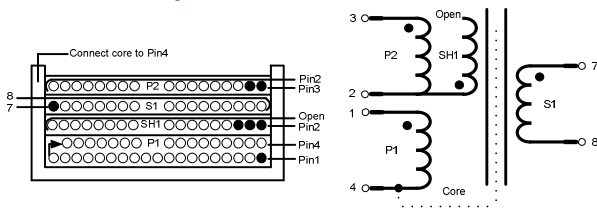

Build Up

WINDING	TERMINAL		TURNS	WIRE			INSULATION	
	START	FINISH		TYPE	SIZE × QTY	LAYER	THICK/WIDE	LAYER
P1	1	4	160	2UEW	0.1Φ×1	3	25µ/8.5mm	2
SH1	2	Open	16	2UEW	0.1Φ×3	1	25µ/8.5mm	2
S1	8	7	20	TEXE Reverse	0.25Φ×1	1	25µ/8.5mm	2
P2	3	2	24	2UEW	0.1Φ×2	2	25µ/8.5mm	2
SH2	Core	4	1	Copper Wire	0.18Φ×1	1	25µ/8.5mm	2

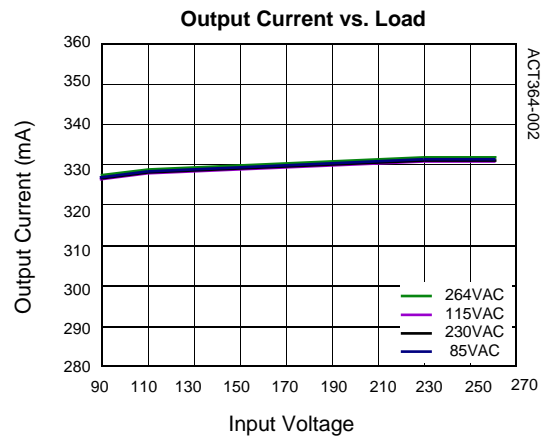

Note: P1 and P2 are Primary, S1 is Secondary (Bobbin: EE-10 Vertical).

EVALUATION KITS	V _{IN}	I _o	LED(s)
ACT364-LED03	85-264VAC	280-350mA	2 or 3

PAR30 7x1W LED Lighting

Input Voltage	Device	LED(s)	Output Voltage	Power Output	Transformer	Topology
85 - 264VAC	ACT365	7	26V	7.8W	EE16	Flyback

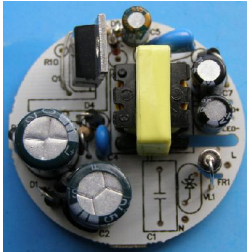

Operation and Application

Figure 1 is the schematic of LED lighting using ACT365 to provide output power of 26V300mA with PF>0.9. This circuit is a typical flyback power supply which includes the AC rectified circuit (BD1, C1, C2), power drive circuit (BD pin, Q1), power factor rectified circuit (D1-D3, C1, C2), secondary rectified circuit (D6, C7, C8) and the IC control circuit. ACT365 is a Primary Side Regulator (PSR) so that the power supply unit can regulate current and voltage without Opto-coupler. Pin 4 and Pin 2 are the VDD and ground pins to provide power for the IC. Pin 3 is the base drive for the NPN transistor. Pin 1 is the switching pin. Pin 5 is the feedback pin that senses the output current and output voltage. Pin 6 is the peak current sense pin. Resistance of R10 determines the output DC cord compensation percentage.

Through a patented PSR technology, this circuit can provide drivers for five (min), or seven (max) LED lights in series due to the wide VDD operation ranges.

Key Component Selection

The maximum output current is decided by formula (1).

$$I_{OUTCC} = \frac{1}{2} \times L_p \times \left(\frac{0.9 \times 0.396}{R_{CS}} \right)^2 \times \left(\frac{\eta \times F_{SW}}{V_{OUTCC}} \right) \quad (1)$$

L_p is the transformer inductance value, R_{CS} is the current sense resistor, which is shown as R9 in the schematic. F_{SW} is the switching

frequency, which design value is 75kHz. η is the overall system efficiency, which value is approximately equal to 75%. V_{OUTCC} is the output voltage, which setting is through the flyback voltage of auxiliary winding and the feedback resistor R5, R6 as shown in formula (2).

$$V_{OUTCC} = V_{REF} \times \left(1 + \frac{R_5}{R_6} \right) \times \frac{N_S}{N_{AUX}} - V_{SEC_R} \quad (2)$$

$N_p/N_s/N_{aux}$ (102/23/13) must be designed correctly to ensure it operates in DCM in all conditions. A design value V_{outcc} equal to 26V and I_{outcc_min} equal to 300mA are used to do the design. N_s and N_{aux} are number of turns of secondary and auxiliary of the transformer. V_{SEC_R} is the forward voltage drop of the output rectifier diode at approximately 0.1A bias. The peak current limit is set by $(0.396 \times 0.9)/R_{CS}$.

Figure 1:

Schematic of LED Lighting Driver

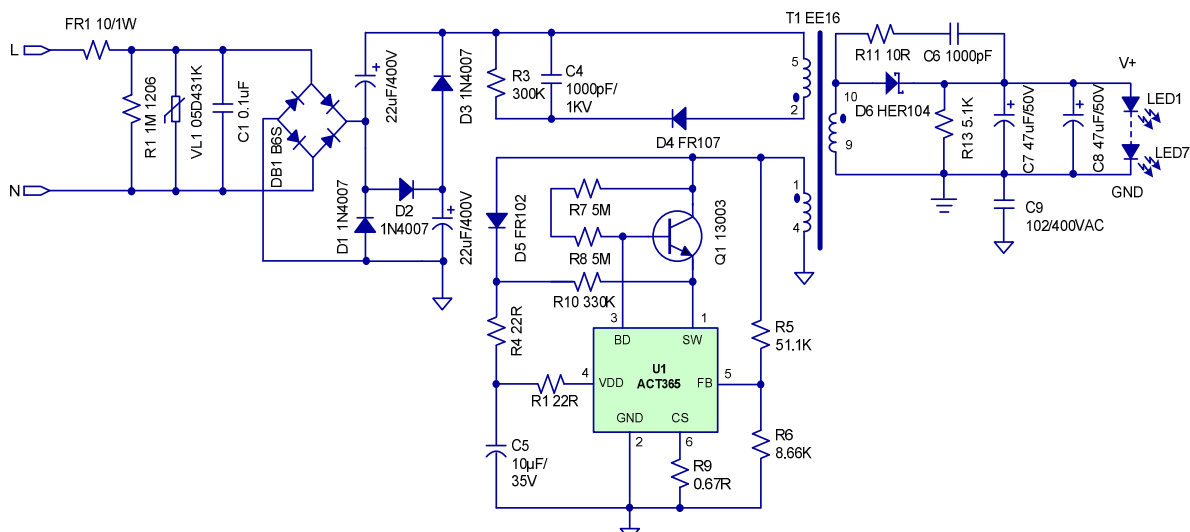

Bill of Materials

REF	DESCRIPTION	MFTR
C1	X1 Capacitor,0.1uF/400V,13x6x11mm	USE
C2,C3	Capacitor,Electrolytic, 22uF/400V, 10x14mm	KSC
C4	Capacitor,Ceramic,1000pF/1KV, DIP	POE
C5	Capacitor,Electrolytic,10uF/35V, 5x11mm	KSC
C6	Capacitor,Ceramic,1000pF/50V,1206	POE
C7,C8	Capacitor,Electrolytic, 47uF/50V, 6.3x12mm	KSC
C9	Y cap,1000pF/275V,Dip	USE
BD1	Bridge,B6S,600V/0.5A,MDI,SMD	PANJIT
D1-D3	Fast Recovery Rectifiers,1N4007, DO-41	Good-Ark
D4	Fast Recovery Rectifier ,FR107,DO-41	Good-Ark
D5	Fast Recovery Rectifier ,FR102,DO-41	Good-Ark
D6	Efficiency Rectifiers, 300V/1A ,HER104, DO-41	Good-Ark
Q1	Transistor, HFE 20-25 NPN, D13003, TO-126	Huawei
PCB1	PCB, L*W*T=φ42x1.0mm, Cem-1,Rev:A	Jintong
FR1	Fusible Resistor, 1W, 10Ω, 5%	TY-OHM
R1	Chip Resistor,1M ohm,1206, 5%	TY-OHM
R3	Chip Resistor, 300K ohm, 1W, 5%	TY-OHM
R4	Chip Resistor, 22 ohm, 0603, 5%	TY-OHM
R5	Chip Resistor, 51.1K ohm, 0805,1%	TY-OHM
R6	Chip Resistor, 8.66K ohm, 0805, 1%	TY-OHM
R7,R8	Chip Resistor, 5M ohm, 0805 , 5%	TY-OHM
R9	Chip Resistor, 0.67 ohm, 1206,1%	TY-OHM
R10	Chip Resistor, 330K ohm, 1/4W, 5%	TY-OHM
R11	Chip Resistor, 10 ohm, 0805, 5%	TY-OHM
R13	Chip Resistor, 5.1K ohm, 0805, 5%	TY-OHM
T1	Transformer, Lp=1.0mH, EE16, Vertical	
U1	IC, ACT365SH-T ,SOP-8	
VL1	Varistor,TVR05471KSY, φ 5,470V	

Electrical Specifications

ITEM	DESCRIPTION	CONDITION	LIMITS
1	Electrical Strength	50Hz, 1 minute, from Primary and Secondary	3kVAC
2	P1 Inductance	Inductance between pin 2 and pin 5 at 1VAC & 1kHz	1.0mH ± 7%
3	P1 Leakage Inductance	Inductance between pins 2 and pin 5 with pins 4-1 and 8-10 shorted	75μH

PCB Layout

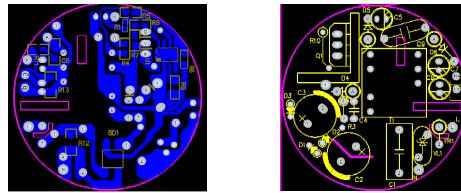

Typical performance Characteristics

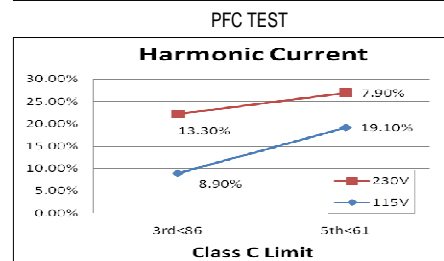
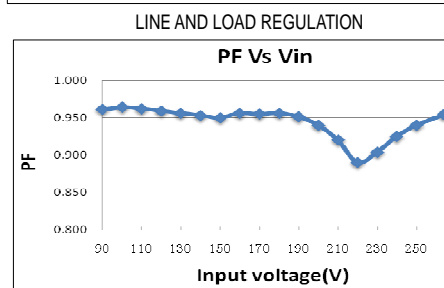
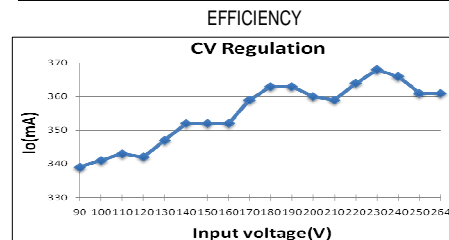
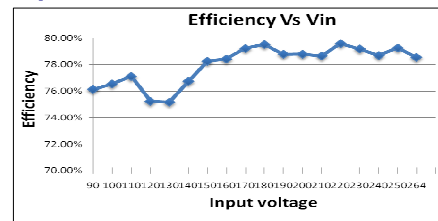

EVALUATION KITS	V _{IN}	V _O	I _O
ACT365-LED04	85-264VAC	26V	300-400mA

Transformer Specifica-

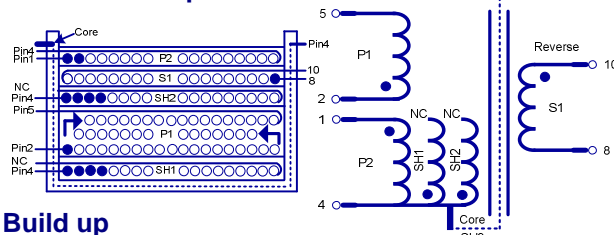

Build up

WINDING	TERMINAL		TURNS	WIRE			INSULATION	
	START	FINISH		TYPE	SIZE × QTY	LAYER	THICK/WIDE	LAYER
SH1	4	NC	14	2UEW	0.12Φ*4	1	0.025*8.5W	2
P1	2	5	102	2UEW	0.23Φ*1	3	0.025*8.5W	2
SH2	4	NC	14	2UEW Reverse	0.12Φ*4	1	0.025*8.5W	2
S1	8	10	23	TEX-E	0.35Φ*1	1	0.025*8.5W	2
P2	1	4	13	2UEW	0.12Φ*2	1	0.025*8.5W	2
SH3	core	4	3	conductor	0.15Φ*1	1	0.025*10	8

Note: SH1,SH2,and SH3 are shielding; P1 and P2 are Primary, S1 is Secondary (Bobbin: EE-16, Vertical).

16V, 5W, 350mA High Efficiency Solutions

Input Voltage	Device	LED(s)	Output Voltage	Power Output	Topology
85 - 264VAC	ACT50	4	16V	5W	Flyback

FEATURES

- Universal AC input
- High efficiency
- Constant Voltage Control & Short Circuit Protection
- CC temperature compensation
- ±5% current accuracy
- Exceed Energy Start 2.0 regulation
- Small SOT23-5 Package

APPLICATIONS

- Off-Line isolated LED Driver

Operation and Application

Figure 1 is the schematic of an offline LED driver using ACT50 to provide a power output of 16V, 350mA. This circuit is a Flyback type power supply which includes the AC rectified circuit (D4, L1, C1, C2), power drive circuit (D9, R6, Q1), output rectified circuit (D10, C8) and the IC supply and control circuit. ACT50 is a very low cost peak

current control PWM controller. Constant voltage control is through OPTO couple and ZD1. Accurate current control is through R10 and the TC compensation circuit (C9, R14, R13).

Key Component Selection

The inductance value is selected to enable to operate the circuit in the CCM mode. The ripple current can be designed to be 20%-40% of the load current. A fast efficiency rectifier D10 is required to achieve higher efficiency. The turn ratio of secondary and auxiliary can be set as to make sure the V_{DD} in a working range. The serial output voltage V_o should be in the range of 12V-16V voltage. The constant output current is set through R10 according formula (1). R14 is a thermal resistor to achieve good output current accuracy in high temperature. V_{BE} is 0.6V at 25°C and 0.55V at 50°C respectively.

$$V_{BE} = I_o \times R10 \times \frac{R14(T)+R13}{R14(T)+R13+R9} \quad (1)$$

ZD1 is selected to set the output voltage constant when it is in open circuit.

Figure 1:
Typical Application Circuit

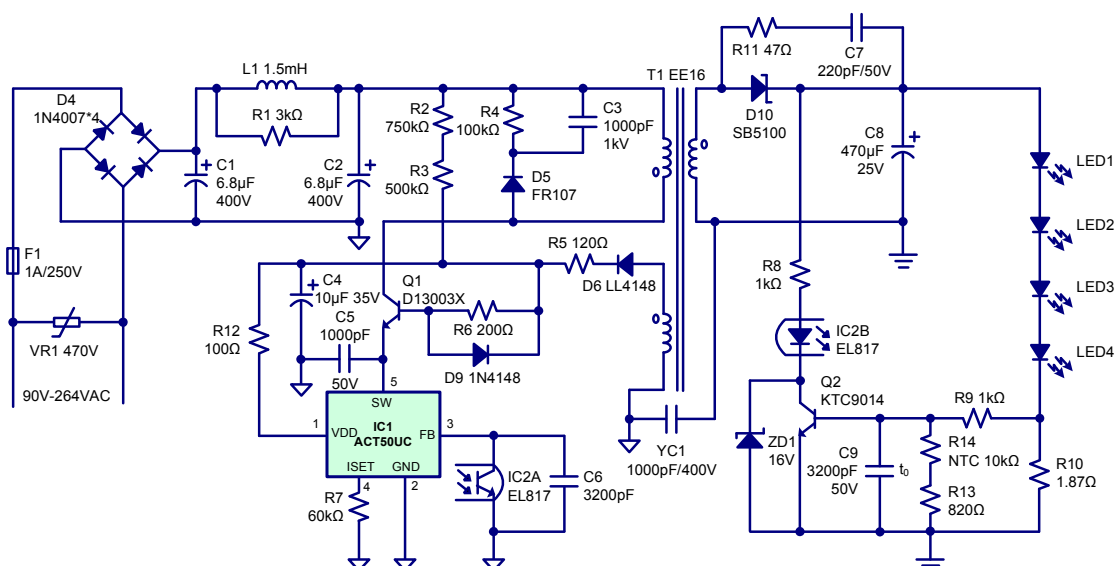

Bill of Materials

REF.	DESCRIPTION	MFTR.
IC1	IC, ACT50UC	Active-Semi
IC2	IC, EL817C, DIP-4	Everlight
C1, C2	Capacitor, Electrolytic, 6.8μF/400V, 8x12mm	KSC
C3	Capacitor, Ceramic, 1000pF/1kV, DIP	POE
C4	Capacitor, Electrolytic, 10μF/35V, 6.3x11mm	KSC
C5	Capacitor, Ceramic, 1000pF/50V, 0805, SMD	POE
C6, C9	Capacitor, Ceramic, 3200pF/50V, 0805, SMD	POE
C7	Capacitor, Ceramic, 220pF/50V, 1206, SMD	POE
C8	Capacitor, Electrolytic, 470μF/25V, 10x8mm	KSC
D1-D4	Diode, Ultra Fast, 1000V/1A 1N4007 DO-41	Good-Ark
D5	Diode, Ultra Fast, FR107, 1000V/1.0A, DO-41	Good-Ark
D6	Diode, Switching, 75V/150mA LL4148 MINI-MELF	Good-Ark
D9	Diode, Switching, 75V/150mA 1N4148, DO-15	Good-Ark
D10	Diode, Super Fast, SB5100, 100V/5.0A, DO-201AD	PANJIT
ZD1	Diode, Zener, GLZJ15A, 16V, 0.5W, MINI-MELF	PANJIT
L1	Axial Inductor, 1.5mH, 0410, DIP	Amode Tech
Q1	Transistor, NPN, 600V, 1.5A, D13003X, TO-26	Hua Wei
Q2	Transistor, NPN, KTC9014, TO-92	KEC
F1	Fuse: 1A 250V 3.6x10mm With Pigtail	Walter
R1	Chip Resistor, 3kΩ, 0805, 5%	TY-OHM
R2	Chip Resistor, 750kΩ, 1206, 5%	TY-OHM
R3	Chip Resistor, 500kΩ, 1206, 5%	TY-OHM
R4	Chip Resistor, 100kΩ, 1/2W, 5%	TY-OHM
R5	Chip Resistor, 120Ω, 0805, 5%	TY-OHM
R6	Chip Resistor, 200Ω, 0805, 5%	TY-OHM
R7	Chip Resistor, 60kΩ, 0805, 1%	TY-OHM
R8, R9	Chip Resistor, 1kΩ, 0805, 5%	TY-OHM
R10	Meter Film Resistor, 1.87Ω, 1W DIP, 1%	TY-OHM
R11	Chip Resistor, 47Ω, 1206, 5%	TY-OHM
R12	Chip Resistor, 100Ω, 1206, 5%	TY-OHM
R13	Chip Resistor, 820Ω, 0805, 5%	TY-OHM
R14	NTC Minus Thermistor Compensation 10kΩ, 5%	Thinking
VR1	Varistor, TVR05471KSY, #5, 470V, ±10%	Thinking
YC1	Y1 Capacitor, 1000pF/400V, DIP	UTX
T1	Transformer, L _p = 1.8mH, EE16	

Build up

WINDING	TERMINAL		TURNS	WIRE			INSULATION	
	START	FINISH		TYPE	SIZE × QTY	LAYER	THICK/WIDE	LAYER
P1	2	1	125	2UEW	0.15Φx1	3	25μ/8.5mm	2
SH1	1	Open	26	2UEW	0.15Φx2	1	25μ/8.5mm	2
S1	8	5	23	2UEW	0.4Φx1	1	25μ/8.5mm	2
SH2	3	Open	1.1	Copper	7mm	1	25μ/8.5mm	1
P2	4	3	21	2UEW	0.15Φx1	1	25μ/8.5mm	1

P1 and P2 are Primary, S1 is Secondary (Bobbin: EE-16 Horizontal)

PCB Top and Bottom Layers

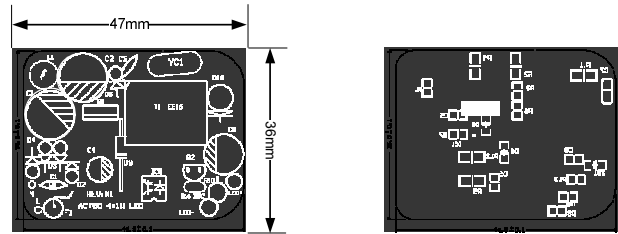

Transformer Specification

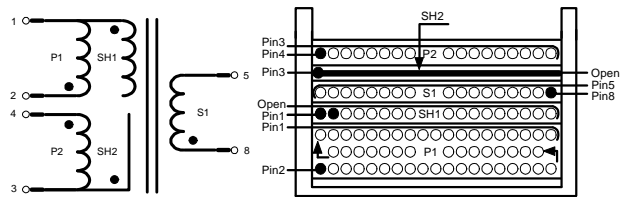

Electrical Specifications

ITEM	DESCRIPTION	CONDITION	LIMITS
1	Electrical Strength	50Hz, 1 minute, from Primary and Secondary	3kVAC
2	P1 Inductance	Inductance between pin 1 and pin 2 at 1VAC & 1kHz	1.8mH ±7%
3	P1 Leakage Inductance	Inductance between pin 1 and pin 2 with pins 3-4 and 5-8 shorted	75μH

Efficiency vs. Input Voltage

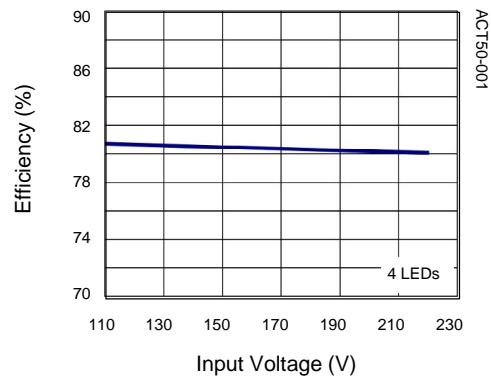

Output Current vs. Input Voltage

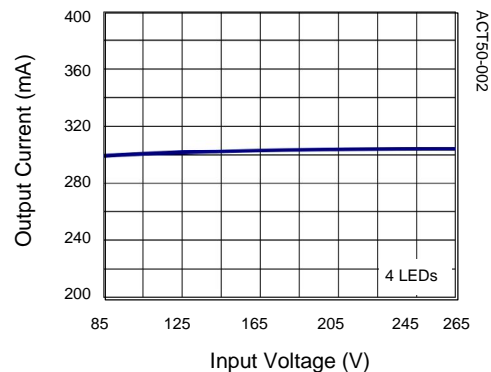

EVALUATION KITS	V _{IN}	I ₀	LED(s)
ACT50UC-T-LED03	85-264VAC	280-350mA	3 or 4

49V, 5W, 128mA High Efficiency Solutions

Input Voltage	Device	LED(s)	Output Voltage	Power Output	Topology
85 - 264VAC	ACT50	14 Serial LED × 8 Line	49V	5W	Flyback

FEATURES

- Universal AC input
- High Efficiency
- Constant Voltage Control & Short Circuit Protection
- CC Temperature Compensation
- ±5% Current Accuracy
- Exceed Energy Start 2.0 Regulation
- Small SOT23-5 Package

APPLICATIONS

- Off-Line isolated LED Driver

Operation and Application

Figure 1 is the schematic of an offline LED driver using ACT50 to provide a power output of 49V, 128mA. This circuit is a flyback type power supply which includes the AC rectified circuit (D4, L1, C1, C2), power drive circuit (D9, R6, Q1), output rectified circuit (D10, C8) and the IC supply and control circuit. ACT50 is a very low cost peak

current control PWM controller. Constant voltage control is through OPTO couple and ZD1. Accurate current control is through R10 and the TC compensation circuit (R9, R13, R14).

Key Component Selection

The inductance value is selected to enable to operate the circuit in the CCM mode. The ripple current can be designed to be 20%-40% of the load current. A fast efficiency rectifier D10 is required to achieve higher efficiency. The turn ratio of secondary and auxiliary can be set as to make sure the V_{DD} in a working range. The serial output voltage V_0 should be in the range of 48V-52V voltage. The constant output current is set through R10 according formula (1). R14 is a thermal resistor to achieve good output current accuracy in high temperature. V_{BE} is 0.6V at 25°C and 0.55V at 50°C respectively.

$$V_{BE} = I_o \times R10 \times \frac{R14(T)+R13}{R14(T)+R13+R9} \quad (1)$$

ZD1 is selected to set the output voltage constant when it is in open circuit.

Figure 1:
Typical Application Circuit

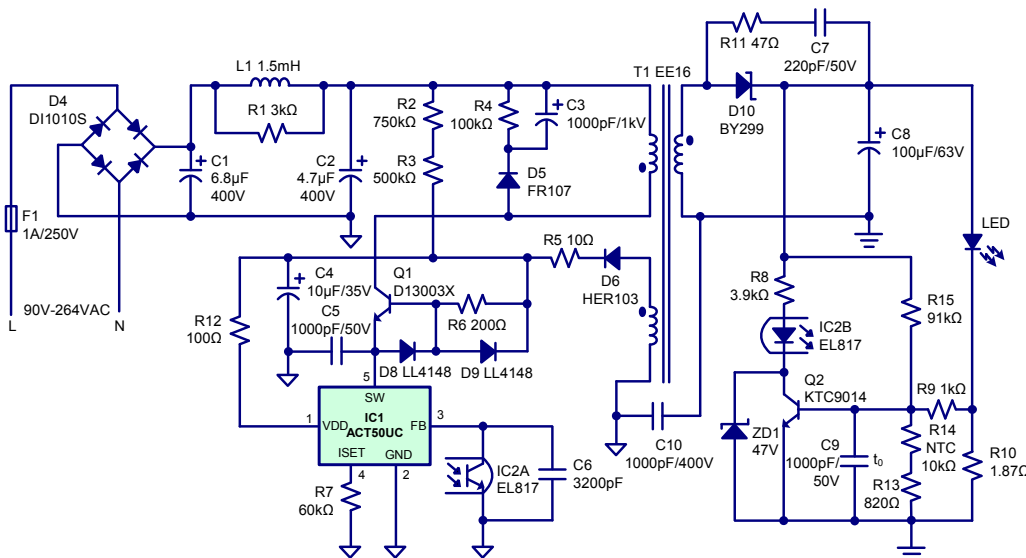

Bill of Materials

REF.	DESCRIPTION	MFTR.
IC1	IC, ACT50UC-T, SOT23-5	Active
IC2	IC, EL817C, DIP-4	Everlight
C1	Capacitor, Electrolytic, 6.8μF/400V, 10×12mm	KSC
C2	Capacitor, Electrolytic, 4.7μF/400V, 8×12mm	KSC
C3	Capacitor, Ceramic, 1000pF/1kV, DIP	POE
C4	Capacitor, Electrolytic, 10μF/35V, 5×11mm	KSC
C5	Capacitor, Ceramic, 1000pF/50V, 0805, SMD	POE
C6	Capacitor, Ceramic, 3300pF/50V, 0805, SMD	POE
C7	Capacitor, Ceramic, 220pF/50V, 1206, SMD	POE
C8	Capacitor, Electrolytic, 100μF/63V, 8×12mm	KSC
C9	Capacitor, Ceramic, 1000pF/50V, 0603, SMD	POE
C10	Safety Capacitor, Y2, 1000pF/400V, DIP	UTX
D4	Bridge Rectifier, 1000V/1A D1010S, SDIP	PANJIT
D5	Diode, Ultra Fast, FR107, 1000V/1.0A, DO-41	Good-Ark
D6	Diode, Ultra Fast, HER103, 200V/1.0A, DO-41	Good-Ark
D8, D9	Diode, Switching, 75V/150mA LL4148 MINI-MELF	Good-Ark
D10	Diode, Super Fast, BY299, 800V/2.0A, DO-201AD	PANJIT
ZD1	Diode, Zener, GLZ47, 47V, 0.5W, MINI-MELF	Good-Ark
L1	Axial Inductor, 1.5mH, 0410, DIP	Amode Tech
Q1	Transistor, NPN, 600V, 1.5A, D13003X, TO-126	Hua Wei
Q2	Transistor, NPN, KTC9014, TO-92	KEC
F1	Fuse: 1A 250V 3.6×10mm With Pigtail	Walter
R1	Meter Film Resistor, 3kΩ, 0805, 5%	TY-OHM
R2	Chip Resistor, 750kΩ, 1206, 5%	TY-OHM
R3	Chip Resistor, 500kΩ, 0805, 5%	TY-OHM
R4	Chip Resistor, 100kΩ, 1206, 5%	TY-OHM
R5	Chip Resistor, 10Ω, 0805, 5%	TY-OHM
R6	Chip Resistor, 200Ω, 0805, 5%	TY-OHM
R7	Chip Resistor, 60kΩ, 0805, 1%	TY-OHM
R8	Chip Resistor, 3.9kΩ, 0805, 5%	TY-OHM
R9	Chip Resistor, 1kΩ, 0805, 5%	TY-OHM
R10	Meter Film Resistor, 1.87Ω, 1/2W DIP, 1%	TY-OHM
R11	Chip Resistor, 47Ω, 1206, 5%	TY-OHM
R12	Chip Resistor, 100Ω, 1206, 5%	TY-OHM
R13	Chip Resistor, 820Ω, 0603, 5%	TY-OHM
R14	NTC Minus Thermistor Compensation 10kΩ, 5%	Thinking
R15	Chip Resistor, 91kΩ, 0603, 5%	TY-OHM
T1	Transformer, L _p = 2.0mH, EE-16	

Build Up

WINDING	TERMINAL		TURNS	WIRE			INSULATION	
	START	FINISH		TYPE	SIZE × QTY	LAYER	THICK/WIDE	LAYER
SH1	1	Open	26	2UEW	0.15Φ×2	1	25μ/8.5mm	2
P1	2	1	125	2UEW	0.15Φ×1	3	25μ/8.5mm	2
SH2	3	Open	26	2UEW	0.15Φ×2	1	25μ/8.5mm	2
S1	8	7	68	TEXE	0.3Φ×1	1	25μ/8.5mm	2
P2	4	3	21	2UEW	0.15Φ×1	1	25μ/8.5mm	3
SH3	3	Open	1.1	Copper	7mm	1	25μ/8.5mm	3

P1 and P2 are Primary, S1 is Secondary (Bobbin: EE-16 Horizontal)

PCB Top and Bottom Layers

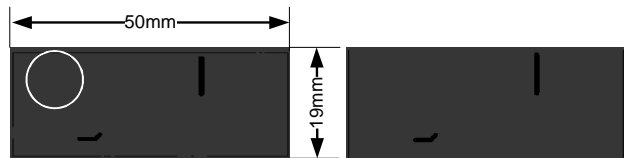

Transformer Specification

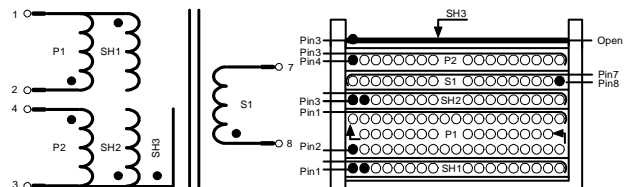

Electrical Specifications

ITEM	DESCRIPTION	CONDITION	LIMITS
1	Electrical Strength	50Hz, 1 minute, from Primary and Secondary	3kVAC
2	P1 Inductance	Inductance between pin 1 and pin 2 at 1VAC & 1kHz	2.0mH ±7%
3	P1 Leakage Inductance	Inductance between pin 1 and pin 2 with pins 3-4 and 7-8 shorted	75μH

Typical Performance Characteristics

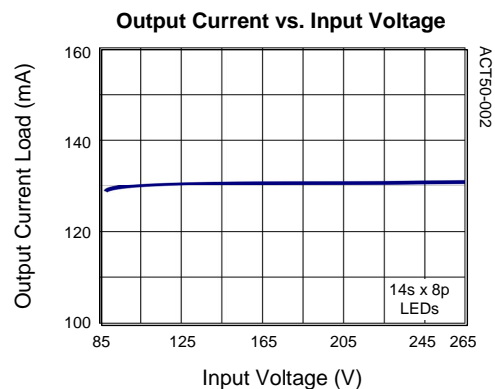
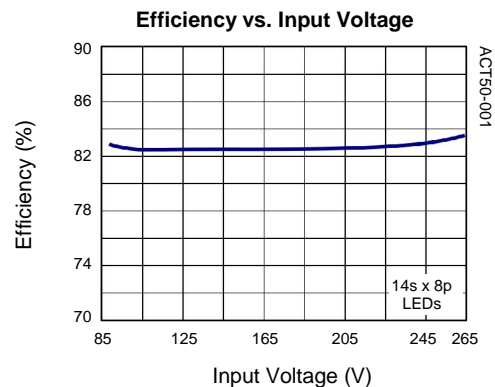

EVALUATION KITS	V _{IN}	I _o	LED(s)
ACT50UC-T-LED05	85-264VAC	115-140mA	14s x 8p (8x16mA)

PAR30 7W LED Lighting

Input Voltage	Device	LED(s)	Output Voltage	Power Output	Topology
85 - 264VAC	ACT50	7	28V	7W	Flyback

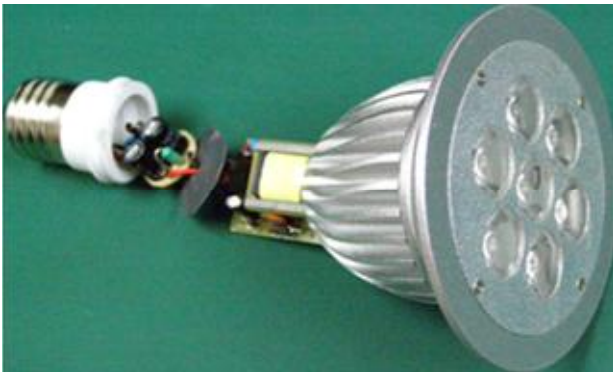

Operation and Application

Figure 1 is the schematic of an offline LED driver using ACT50 to provide a power output of 28V, 350mA. This circuit is a Flyback type power supply which includes the AC rectified circuit (BD1, L1, C1, C2), power drive circuit (D3, R6, Q1), output rectified circuit (D4, C8, C9) and the IC supply and control circuit. ACT50 is a very low cost peak current control PWM controller. Constant voltage control is through OPTO couple and ZD1. Accurate

current control is through R13, R14 and the TC compensation circuit (RT1) R15.

Key Component Selection

The inductance value is selected to enable to operate the circuit in the CCM mode. The ripple current can be designed to be 20%-40% of the load current. A fast efficiency rectifier D4 is required to achieve higher efficiency. The turn ratio of secondary and auxiliary can be set as to make sure the V_{DD} in a working range. The serial output voltage V_0 should be in the range of 21V-28V voltage. The constant output current is set through R13, R14 according formula (1). RT1 is a thermal resistor to achieve good output current accuracy in high temperature. V_{BE} is 0.6V at 25°C and 0.55V at 50°C respectively.

$$V_{BE} = I_o \times \frac{R13 \times R14}{R13 + R14} \times \frac{RT1 + R15}{RT1 + R12 + R15} \quad (1)$$

ZD1 is selected to set the output voltage constant when it is in open circuit.

Figure 1:
Typical Application Circuit

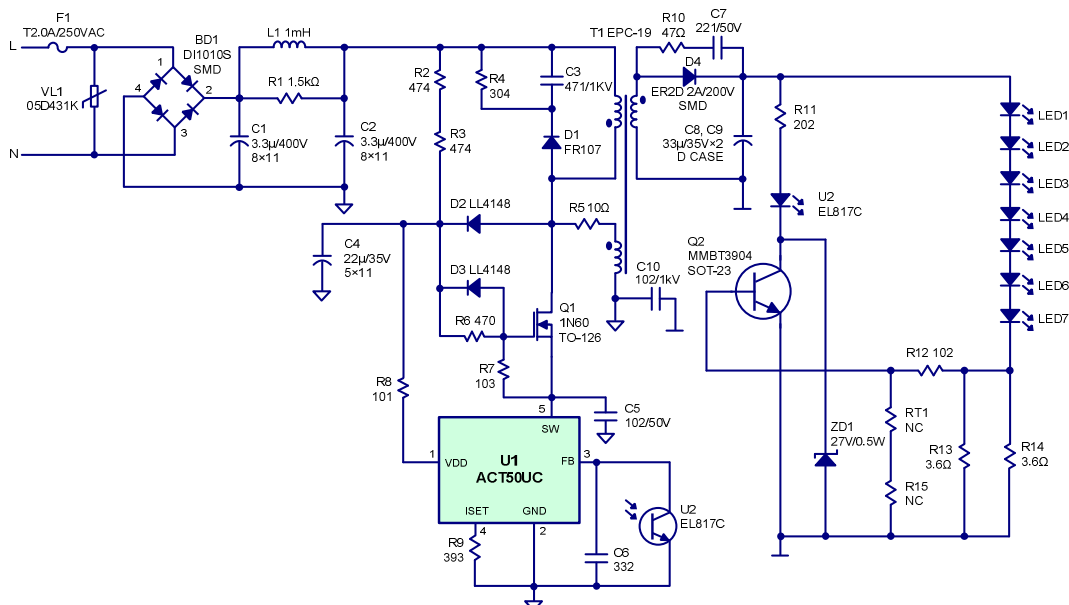

Bill of Materials

REF	DESCRIPTION	MFTR
U1	IC, ACT50UC, SOT23-5	Active
U2	IC, EL817C, DIP-4	Everlight
C1, C2	Capacitor Electrolytic, 3.3μF/400V, 8×12mm	KSC
C3	Capacitor Ceramic, 470pF/1KV, DIP	POE
C4	Capacitor Electrolytic, 22μF/35V, 5×11mm	KSC
C5	Capacitor Ceramic, 1000pF/50V,0805	POE
C6	Capacitor Ceramic, 3300pF/25V,0603	POE
C7	Capacitor Ceramic, 220pF/50V,0805	POE
C8, C9	Capacitor Tantalum, 33μF/35V, D Case	AVX
C10	Capacitor Ceramic, 1000pF/1KV, DIP	POE
BD1	Bridge Rectifier, 1000V/1A, D11010S, SDIP	PANJIT
D1	Diode, Ultra Fast, FR107, 1000V/1.0A, DO-41	Good-Ark
D2	Diode, Switching, 75V/150mA, LL4148, MICRO-MELF	Good-Ark
D3	Diode, Switching, 75V/150mA, LL4148, MICRO-MELF	Good-Ark
D4	Diode, Ultra Fast, ER2D, 200V/2.0A, SMD	PANJIT
ZD1	Diode, Zener, GMZJ27A ,27V, 0.5W, MICRO-MELF	PANJIT
Q1	Transistor, Mosfet, 1N60, TO-126	UTC
Q2	Amplifier Transistor, NPN, MMBT3904, SOT-23	
F1	Fuse: 2.0A 250V 3.6 × 10mm With Pigtail, Ceramic tube	Walter
L1	Axial Inductor, 1mH, 0410, DIP	AmodeTech
PCB1	ACT50 PCB, Φ18mm, T = 1.6mm, CEM-1, Rev: A	Jintong
PCB2	ACT50 PCB, L × W × T = 29 × 28 × 1.0mm, FR-4, Rev: A	Jintong
R1	Chip Resistor, 1.5kΩ, 1206, 5%	TY-OHM
R2	Chip Resistor, 470kΩ, 1206, 5%	TY-OHM
R3	Chip Resistor, 470kΩ, 1206, 5%	TY-OHM
R4	Chip Resistor, 300kΩ, 1206, 5%	TY-OHM
R5	Chip Resistor, 10Ω, 1206, 5%	TY-OHM
R6	Chip Resistor, 47Ω, 0805, 5%	TY-OHM
R7	Chip Resistor, 10kΩ, 0805, 5%	TY-OHM
R8	Chip Resistor, 100Ω, 0805, 5%	TY-OHM
R9	Chip Resistor, 39kΩ, 0603, 1%	TY-OHM
R10	Chip Resistor, 47Ω, 1206, 5%	TY-OHM
R11	Chip Resistor, 2.0kΩ, 0603, 5%	TY-OHM
R12	Chip Resistor, 1kΩ, 0603, 5%	TY-OHM
R13, R14	Chip Resistor, 3.6Ω, 1206, 1%	TY-OHM
R15	NC	TY-OHM
RT1	NC	Thinking
T1	Transformer, L _p = 1.8mH, EPC-19	
VR1	Varistor, TVR05431KSY, ϕ5, 430V, ±10%, DIP	Thinking

Build up

WINDING	TERMINAL		TURNS	WIRE			INSULATION	
	START	FINISH		TYPE	SIZE × QTY	LAYER	THICK/WIDE	LAYER
P1	3	1	95	2UEW	0.25Φ×1	1	25μ/8.5mm	2
SH1	4	Open	40	2UEW	0.15Φ×2	1	25μ/8.5mm	2
S1	11	10	40	TEXE	0.45Φ×1	1	25μ/8.5mm	2
SH2	4	Open	0.9	Copper	7mm	1	25μ/8.5mm	2
P2	5	4	20	2UEW	0.15Φ×2	1	25μ/8.5mm	2
SH3	4	Open	1.1	Copper	7mm (Epiboly)	1	25μ/8.5mm	2

P1 and P2 are Primary, S1 is Secondary (Bobbin: EPC19 Horizontal)

PCB Layout

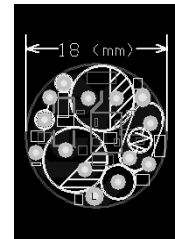
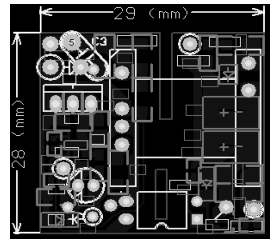

Transformer Specification

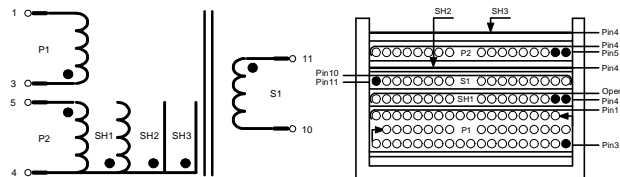

Electrical Specifications

ITEM	DESCRIPTION	CONDITION	LIMITS
1	Electrical Strength	50Hz, 1 minute, from primary and secondary	3kVAC
2	P1 Inductance	Inductance between pins 1 and 3 at 1VAC & 1kHz	1.8mH ±7%
3	P1 Leakage Inductance	Inductance between pins 1 and 3 with pins 5-4 and 11-10 shorted	75μH

Efficiency vs. Input Voltage

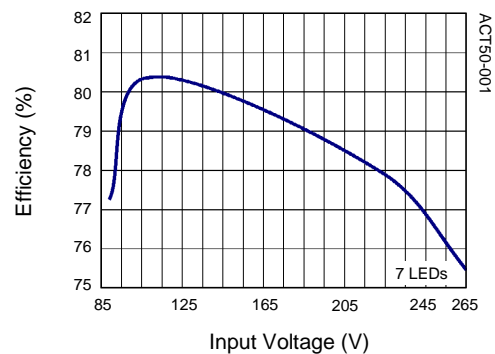

Output Current vs. Input Voltage

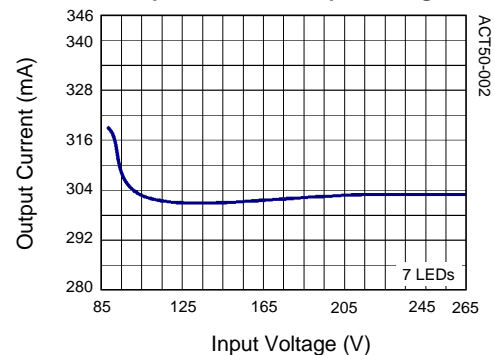

EVALUATION KITS	V _{IN}	I _o	LED(s)
ACT50UC-T-LED04	85-264VAC	280-350mA	7

Bill of Materials

REF.	DESCRIPTION	MFTR.
IC1	IC, ACT50UC	Active-Semi
IC2	IC, EL817C, DIP-4	Everlight
C1, C2	Capacitor, Electrolytic, 10μF/400V, 8x12mm	KSC
C4	Capacitor, Electrolytic, 22μF/35V, 5x11mm	KSC
C5	Capacitor, Ceramic, 1000pF/50V, 0805, SMD	POE
C6, C10	Capacitor, Ceramic, 3300pF/50V, 0805, SMD	POE
C8, C9	Capacitor, Electrolytic, 100μF/50V, 8x12mm	KSC
BD1	Bridge Rectifier, 1000V/1A, DI1010S, SDIP	Good-Ark
D6	Diode, Super Fast, HER103, 200V/1.0A, DO-41	PANJIT
D9	Diode, Switching, 75V/150mA 1N4148, DIP	Good-Ark
D10	Fast Efficient Rectifier, BYV26B, 500V/1A, DO-204AP	GS
ZD1	Diode, Zener, GLZ39A, 39V, 0.5W, MINI-MELF	Good-Ark
L1	Axial Inductor, 300μH, 0410, DIP	Amode Tech
Q1	Transistor, NPN, 600V, 1.5A, D13003X, TO-126	Hua Wei
Q2	Transistor, NPN, KTC9014, TO-92	KEC
F1	Fuse: 1A 250V 3.6 x 10mm With Pigtail	Walter
R1	Chip Resistor, 3kΩ, 0805, 5%	TY-OHM
R2	Chip Resistor, 750kΩ, 1206, 5%	TY-OHM
R3	Chip Resistor, 750kΩ, 1206, 5%	TY-OHM
R5	Chip Resistor, 10Ω, 0805, 5%	TY-OHM
R6	Chip Resistor, 200Ω, 0805, 5%	TY-OHM
R7	Chip Resistor, 39kΩ, 0805, 1%	TY-OHM
R8	Chip Resistor, 6kΩ, 0805, 5%	TY-OHM
R9	Chip Resistor, 1kΩ, 0805, 5%	TY-OHM
R10	Film Resistor, 1.87Ω, 1/2W DIP, 1%	TY-OHM
R12	Chip Resistor, 100Ω, 1206, 5%	TY-OHM
R13	Chip Resistor, 820Ω, 0603, 5%	TY-OHM
R14	NTC Minus Thermistor Compensation 10kΩ, 5%	Thinking
VR1	Varistor, TVR05471KSY, φ5, 470V, ±10%	Thinking
T1	Transformer, L _p = 2.6mH, EE-19	

Transformer Specification

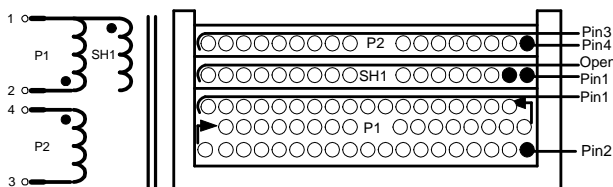

Build up

WINDING	TERMINAL		TURNS	WIRE			INSULATION	
	START	FINISH		TYPE	SIZE × QTY	LAYER	THICK/WIDE	LAYER
P1	2	1	143	2UEW	0.3Φ×1	1	25μ/8.5mm	2
SH2	1	Open	30	2UEW	0.15Φ×2	1	25μ/8.5mm	2
P2	4	3	55	2UEW	0.15Φ×1	1	25μ/8.5mm	3

P1 and P2 are Primary, P2 is Secondary (Bobbin: EE-19 Horizontal)

PCB Top and Bottom Layers

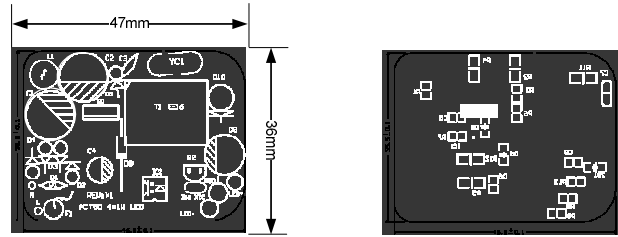

Electrical Specifications

ITEM	DESCRIPTION	CONDITION	LIMITS
1	Electrical Strength	50Hz, 1 minute, from Primary and Secondary	3kVAC
2	P1 Inductance	Inductance between pins 1 and 2 at 1VAC & 1kHz	2.6mH ±7%
3	P1 Leakage Inductance	Inductance between pin 1 and pin 2 with pins 3-4 shorted	75μH

Typical Performance Characteristics

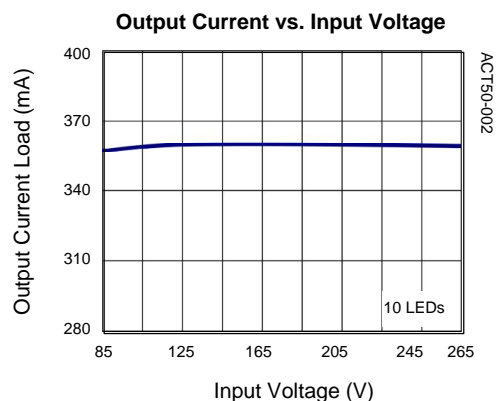
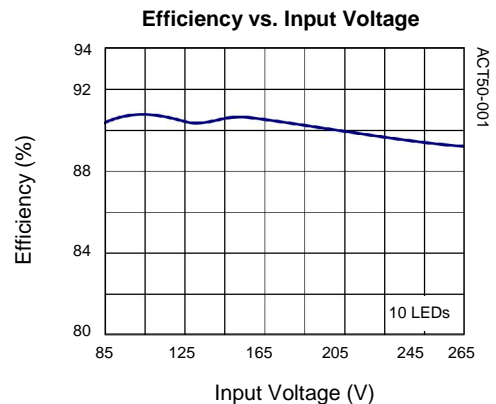

EVALUATION KITS	V _{IN}	I _o	LED(s)
ACT50UC-T-LED11	85-264VAC	280-350mA	9 or 10

PAR38 12W LED Lighting

Input Voltage	Device	LED(s)	Output Voltage	Power Output	Topology
85 - 264VAC	ACT50	12	42V	12W	Flyback

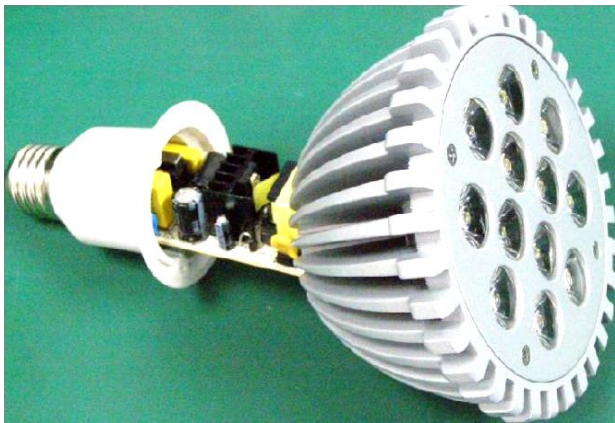

Operation and Application

Figure 1 is the schematic of an offline LED driver using ACT50 to provide a power output of 42V, 350mA. This circuit is a Flyback type power supply which includes the AC rectified circuit (D1-D4, R1, C3, C4), power drive circuit (D10, R9, Q1), output rectified circuit (D11, C10, C11, C12), and the IC supply and control circuit. ACT50 is a very low cost peak current control PWM controller. Constant

voltage control is through OPTO couple and ZD1. Accurate current control is through R14, R15, R16, and the TC compensation circuit (RT1, R17).

Key Component Selection

The inductance value is selected to enable to operate the circuit in the CCM mode. The ripple current can be designed to be 20%-40% of the load current. A fast efficiency rectifier D11 is required to achieve higher efficiency. The turn ratio of secondary and auxiliary can be set as to make sure the V_{DD} in a working range. The serial output voltage V_o should be in the range of 42V-48V voltage. The constant output current is set through R14, R15 according formula (1). RT1 is a thermal resistor to achieve good output current accuracy in high temperature. V_{BE} is 0.6V at 25°C and 0.55V at 50°C respectively.

$$V_{BE} = I_o \times \frac{R14 \times R15}{R14 + R15} \times \frac{RT1 + R17}{RT1 + R16 + R17} \quad (1)$$

ZD1 is selected to set the output voltage constant when it is in open circuit.

Figure 1:
Typical Application Circuit

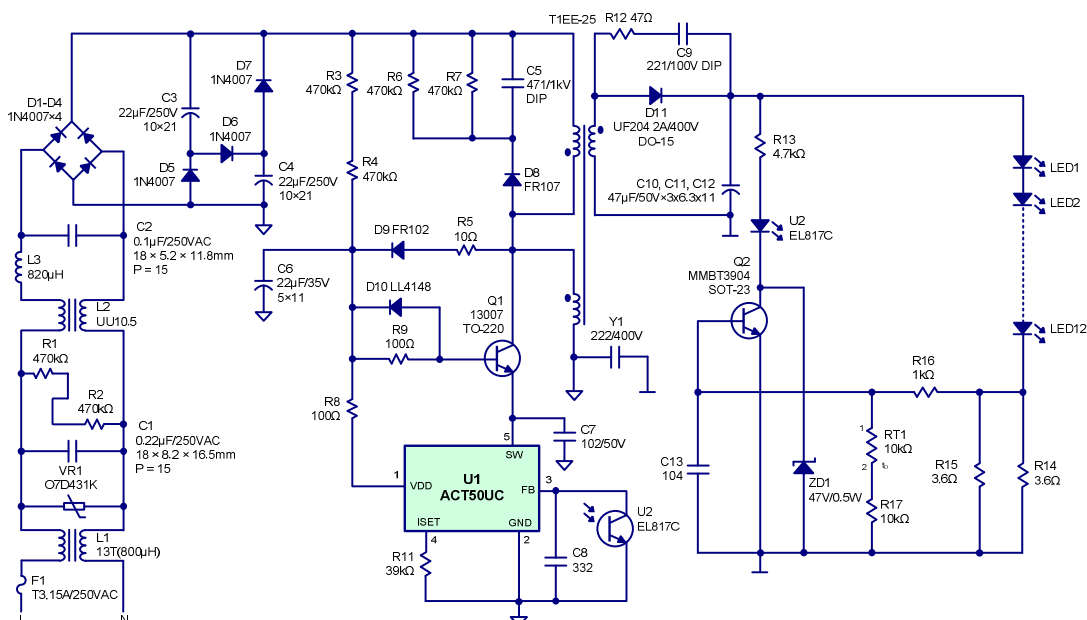

Bill of Materials

REF.	DESCRIPTION	MFTR.
U1	IC, ACT50	Active-Semi
U2	IC, EL817C, DIP-4	Everlight
C1	Cap-X2 0.22μF/250V, 18x8.2x16.5mm, P=15mm	UTX
C2	Cap-X2 0.1μF/250V, 18x5.2x11.8mm, P=15mm	UTX
C3-C4	Capacitor, Electrolytic, 22μF/400V, 10×21mm	KSC
C5	Capacitor, Ceramic, 470pF/1kV, DIP	POE
C6	Capacitor, Electrolytic, 22μF/35V, 5×11mm	KSC
C7	Capacitor, Ceramic, 1000pF/50V, 0805	POE
C8	Capacitor, Ceramic, 3300pF/25V, 0805	POE
C9	Capacitor, Ceramic, 220pF/1kV, DIP	POE
C10-C12	Capacitor, Electrolytic, 47μF/50V, 6.3×11mm	KSC
C13	Capacitor, Ceramic, 0.1μF/25V, 0805	POE
Y1	Y1 Capacitor, 2200pF/400VAC, DIP	POE
D1-D7	Rectifier, 1000V/1A, 1N4007 DO-41	Good-Ark
D8	Diode, Ultra Fast, FR107, 1000V/1A DO-41	Good-Ark
D9	Diode, Ultra Fast, FR102, 100V/1A DO-41	Good-Ark
D10	Diode, Switching, 75V/150mA, LL4148	Good-Ark
D11	Diode, Ultra Fast, UF204, 400V/2.0A, DO-15	Good-Ark
ZD1	Diode, Zener, GMZ47A, 47V, 0.5W, MICRO-MELF	PANJIT
Q1	Transistor, NPN, D13007, TO-220	Huawei
Q2	Amplifier Transistor, NPN, MMBT3904, SOT-23	
F1	Fuse: 3.15A 250V 3.6×10mm With Pigtail, Ceramic tube.	Walter
L1	Inductor, T9×5×3C, R12kΩ 13T 800μH	
L2	Inductor, LP = 28-40mH, Bobbin UU10.5	
L3	Axial Inductor, 820μH, 0410, DIP	
R1, R4, R6, R7	Chip Resistor, 470kΩ, 1206, 5%	TY-OHM
R5	Chip Resistor, 10Ω, 1206, 5%	TY-OHM
R8	Chip Resistor, 100Ω, 1206, 5%	TY-OHM
R9	Chip Resistor, 47Ω, 1206, 5%	TY-OHM
R11	Chip Resistor, 39kΩ, 0805, 5%	TY-OHM
R12	Chip Resistor, 47Ω, 1206, 5%	TY-OHM
R13	Chip Resistor, 4.7kΩ, 0603, 5%	TY-OHM
R14, R15	Chip Film Resistor, 3.6Ω, 1206, 1%	TY-OHM
R16	Chip Resistor, 1kΩ, 0603, 5%	TY-OHM
R17	Chip Resistor, 10kΩ, 0603, 5%	TY-OHM
T1	Transformer EE-25, BobbinTF-2202 10Pin Vertical, L _p = 1.2mH	
RT1	NTC minus Thermistor Compensation 10kΩ, ϕ5mm, 5%	TY-OHM
VR1	Varistor, TVR07431KSY, ϕ7, 430V, ±10%, DIP	Thinking
H/S	Heat Sunk: JD-YI Series L=20mm, Black	JIEDA
For Q1	Silicon Insulation: TO-220	
For Q1	Insulation Washer: Φ3mm	
For Q1	Pan Head Screw+Spring washer Φ3×8mm	
For Q1	Nut Φ3	

Transformer Specification

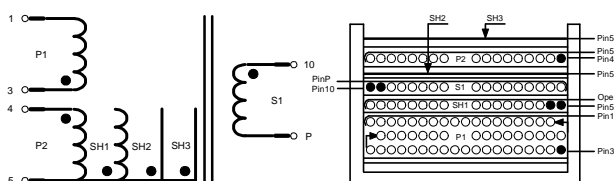

PCB Layout

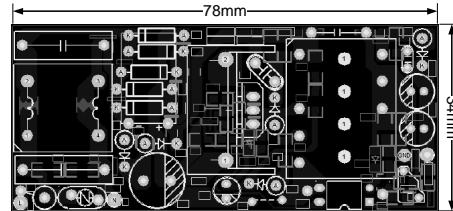

Build Up

WINDING	TERMINAL		TURNS	WIRE			INSULATION	
	START	FINISH		TYPE	SIZE × QTY	LAYER	THICK/WIDE	LAYER
P1	3	1	83	2UEW	0.25Φ×1	2	25μ/8.5mm	2
SH1	5	Open	40	2UEW	0.15Φ×2	1	25μ/8.5mm	2
S1	10	P	41	TEXE	0.2Φ×2	1	25μ/8.5mm	2
SH2	5	Open	0.9	Copper	7mm	1	25μ/8.5mm	2
P2	4	5	12	2UEW	0.3Φ×1	1	25μ/8.5mm	2
SH3	5	Open	1.1	Copper	7mm (Core Outer)	1	25μ/8.5mm	2

P1 and P2 are Primary, P1 is Secondary (Bobbin: EE-25 Horizontal)

Electrical Specifications

ITEM	DESCRIPTION	CONDITION	LIMITS
1	Electrical Strength	50Hz, 1 minute, from Primary and Secondary	3kVAC
2	P1 Inductance	Inductance between pin 1 and pin 3 at 1VAC & 1kHz	1.2mH ±7%
3	P1 Leakage Inductance	Inductance between pin 1 and pin 3 with pins 5-4 and 10-P shorted	75μH

Efficiency vs. Input Voltage

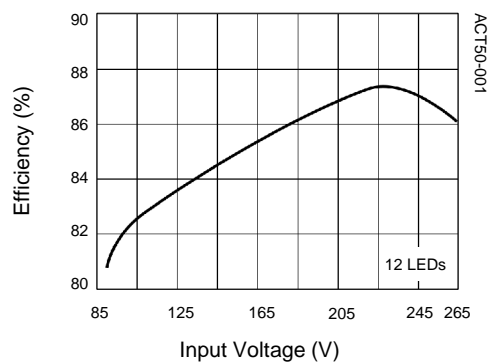

Output Current vs. Input Voltage

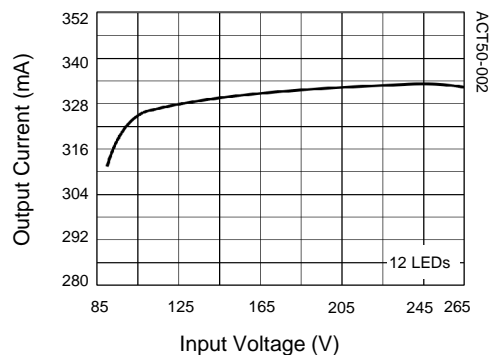

EVALUATION KITS	V _{IN}	I ₀	LED(s)
ACT50UC-T-LED06	85-264VAC	280-350mA	12

35V, 12W, 350mA High Efficiency Solutions

Input Voltage	Device	LED(s)	Output Voltage	Power Output	Topology
85 - 264VAC	ACT50	10	35V	12W	Flyback

FEATURES

- Universal AC Input
- High Efficiency
- Constant Voltage Control & Short Circuit Protection
- CC Temperature Compensation
- ±5% Current Accuracy
- Exceed Energy Start 2.0 Regulation
- Small SOT23-5 Package

APPLICATIONS

- Off-Line Isolated LED Driver

Operation and Application

Figure 1 is the schematic of an offline LED driver using ACT50 to provide a power output of 35V, 350mA. This circuit is a flyback type power supply which includes the AC rectified circuit (D1-D4, L1, R1, C1, C2), power drive circuit (D9, R6, Q1), output rectified circuit (D10, C8, C9) and the IC supply and control circuit. ACT50 is a very low cost

peak current control PWM controller. Constant voltage control is through OPTO coupler and ZD1. Accurate current control is through R10 and the TC compensation circuit (R9, R13, R14).

Key Component Selection

The inductance value is selected to enable to operate the circuit in the CCM mode. The ripple current can be designed to be 20%-40% of the load current. A fast efficiency rectifier D10 is required to achieve higher efficiency. The turn ratio of secondary and auxiliary can be set as 2.8 to make sure the V_{DD} in a working range. The serial output voltage V_o should be in the range of 35V-40V voltage. The constant output current is set through R10 according formula (1). R14 is a thermal resistor to achieve good output current accuracy in high temperature. V_{BE} is 0.6V at 25°C and 0.55V at 50°C respectively.

$$V_{BE} = I_o \times R10 \times \frac{R14(T)+R13}{R14(T)+R13+R9} \quad (1)$$

ZD1 is selected to set the output voltage constant when it is in open circuit.

Figure 1:
Typical Application Circuit

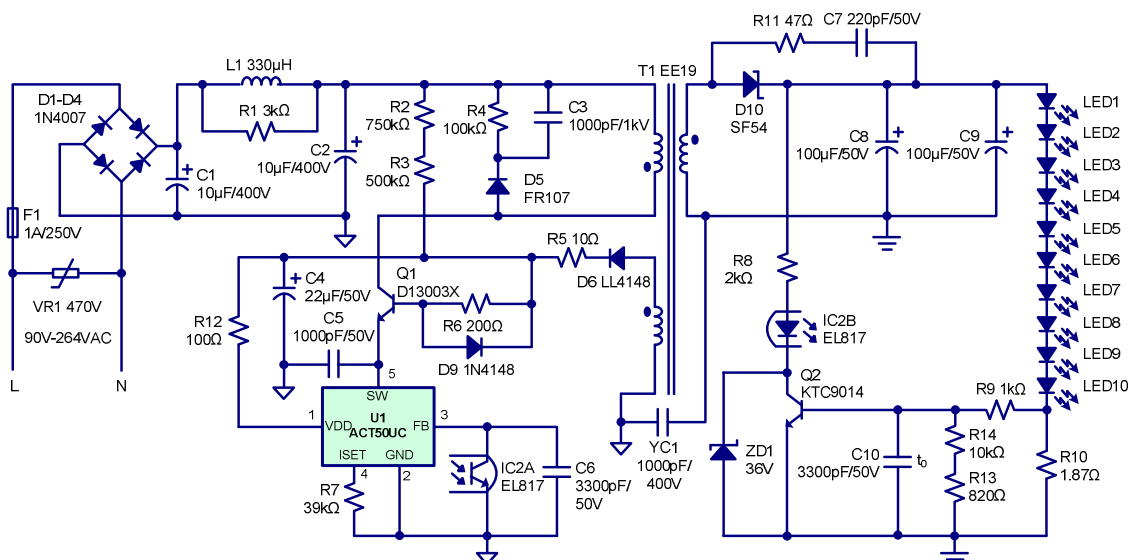

Bill of Materials

REF.	DESCRIPTION	MFTR.
IC1	IC, ACT50UC-T, SOT23-5	Active-Semi
IC2	IC, EL817C, DIP-4	Everlight
C1, C2	Capacitor, Electrolytic, 10μF/400V, 8×12mm	KSC
C3	Capacitor, Ceramic, 1000pF/1kV	POE
C4	Capacitor, Electrolytic, 22μF/50V, 5×11mm	KSC
C5	Capacitor, Ceramic, 1000pF/50V, 0805, SMD	POE
C6,C10	Capacitor, Ceramic, 3300pF/50V, 0805, SMD	POE
C7	Capacitor, Ceramic, 220pF/50V, 1206, SMD	POE
C8, C9	Capacitor, Electrolytic, 100μF/50V, 8×12mm	KSC
D1-D4	Diode, Ultra Fast, 1000V/1A 1N4007 DO-41	Good-Ark
D5	Diode, Ultra Fast, FR107, 1000V/1.0A, DO-41	Good-Ark
D6	Diode, Switching, 75V/150mA LL4148 MINI-MELF	Good-Ark
D9	Diode, Switching, 75V/150mA 1N4148, DO-15	Good-Ark
D10	Diode, Super Fast, SF54, 300V/3.0A, DO-201AD	Good-Ark
ZD1	Diode, Zener, GLZJ36A, 36V, 0.5W, MINI-MELF	Good-Ark
L1	Axial Inductor, 330μH, 0410, DIP	Amode Tech
Q1	Transistor, NPN, 600V, 1.5A, D13003X, TO-26	Hua Wei
Q2	Transistor, NPN, KTC9014, TO-92	KEC
F1	Fuse: 1A 250V 3.6×10mm With Pigtail	Walter
R1	Chip Resistor, 3kΩ, 0805, 5%	TY-OHM
R2	Chip Resistor, 750kΩ, 1206, 5%	TY-OHM
R3	Chip Resistor, 500kΩ, 0805, 5%	TY-OHM
R4	Chip Resistor, 100kΩ, 1206, 5%	TY-OHM
R5	Chip Resistor, 100Ω, 0805, 5%	TY-OHM
R6	Chip Resistor, 200Ω, 0805, 5%	TY-OHM
R7	Chip Resistor, 39kΩ, 0805, 1%	TY-OHM
R8	Chip Resistor, 2kΩ, 0805, 5%	TY-OHM
R9	Chip Resistor, 1kΩ, 0805, 5%	TY-OHM
R10	Meter Film Resistor, 1.87Ω, 1/2W DIP, 1%	TY-OHM
R11	Chip Resistor, 47Ω, 1206, 5%	TY-OHM
R12	Chip Resistor, 100Ω, 1206, 5%	TY-OHM
R13	Chip Resistor, 820Ω, 0603, 5%	TY-OHM
R14	NTC Minus Thermistor Compensation 10kΩ, 5%	Thinking
VR1	Varistor, TVR05471KSY, ϕ5, 470V, ±10%	Thinking
YC1	Y1 Capacitor, 1000pF/400V, DIP	UTX
T1	Transformer, L _p = 1.8mH, EE19	

Build Up

WINDING	TERMINAL		TURNS	WIRE			INSULATION	
	START	FINISH		TYPE	SIZE × QTY	LAYER	THICK/WIDE	LAYER
SH1	1	Open	30	2UEW	0.15Φ×2	1	25μ/8.5mm	2
P1	2	1	110	2UEW	0.25Φ×1	2	25μ/8.5mm	2
SH2	3	Open	30	2UEW	0.15Φ×2	1	25μ/8.5mm	2
S1	8	5	40	TEXE	0.45Φ×1	1	25μ/8.5mm	2
SH3	3	Open	1.1	Copper	7mm	1	25μ/8.5mm	3
P2	4	3	18	2UEW	0.15Φ×1	1	25μ/8.5mm	3

P1 and P2 are Primary, S1 is Secondary (Bobbin: EE-19 Horizontal)

PCB Top and Bottom Layers

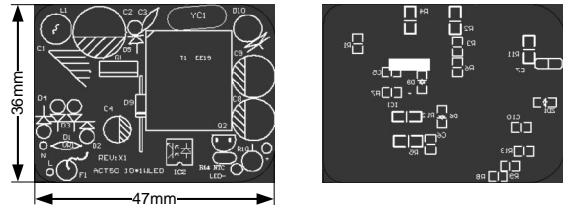

Transformer Specification

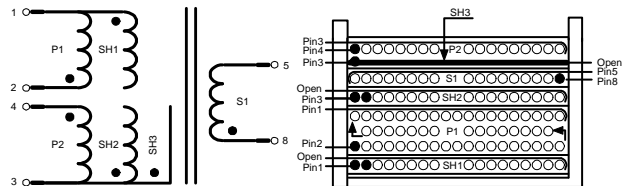

Electrical Specifications

ITEM	DESCRIPTION	CONDITION	LIMITS
1	Electrical Strength	50Hz, 1 minute, from Primary and Secondary	3kVAC
2	P1 Inductance	Inductance between pin 1 and pin 2 at 1VAC & 1kHz	1.8mH ±7%
3	P1 Leakage Inductance	Inductance between pin 1 and pin 2 with pins 3-4 and 5-8 shorted	75μH

Typical Performance Characteristics

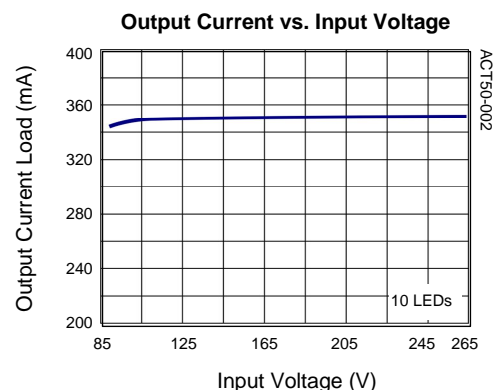
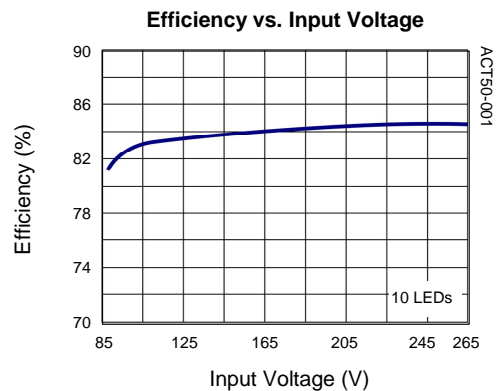

EVALUATION KITS	V _{IN}	I ₀	LED(s)
ACT50UC-T-LED07	85-264VAC	280-350mA	9 or 10

28V, 21W, 350mA High Efficiency Solutions

Input Voltage	Device	LED(s)	Output Voltage	Power Output	Topology
85 - 264VAC	ACT50	7LED or 300mA or 600mA or 900mA	28V	21W	Buck

FEATURES

- Universal AC input
- High Efficiency
- Constant Voltage Control & Short Circuit Protection
- CC Temperature Compensation
- ±5% Current Accuracy
- Exceed Energy Start 2.0 Regulation
- Small DIP-8 Package

APPLICATIONS

- Off-Line Isolated LED Driver

Operation and Application

Figure 1 is the schematic of an offline LED driver using ACT50 to provide a power output of 28V, 350mA. This circuit is a buck type power supply which includes the AC rectified circuit (D1-D7, L1-L3, C1-C5), power drive circuit (D10, R11, Q1), output rectified circuit (D11, C11, C12) and the IC supply and control circuit. ACT50 is a very low cost peak current control PWM controller. Constant

voltage control is through OPTO couple and D12. Accurate current control is through R13 and LM358 control circuit.

Key Component Selection

The inductance value is selected to enable to operate the circuit in the CCM mode. The ripple current can be designed to be 20%-40% of the load current. A fast efficiency rectifier D11 is required to achieve higher efficiency. The turn ratio of secondary and auxiliary can be set as to make sure the V_{DD} in a working range. The serial output voltage V_0 should be in the range of 28V-32V voltage. The constant output current is set through R13 according formula (1, 2, 3).

$$I_{O1} = 2.5 \times \frac{(R18+R19) // (R20+R21)}{R17 \times R13} \quad (1)$$

$$I_{O2} = 2.5 \times \frac{(R18+R19) // (R22+R23)}{R17 \times R13} \quad (2)$$

$$I_{O3} = 2.5 \times \frac{(R18+R19) // (R24+R25)}{R17 \times R13} \quad (3)$$

D12 is selected to set the output voltage constant when it is in open circuit.

Figure 1:
Typical Application Circuit

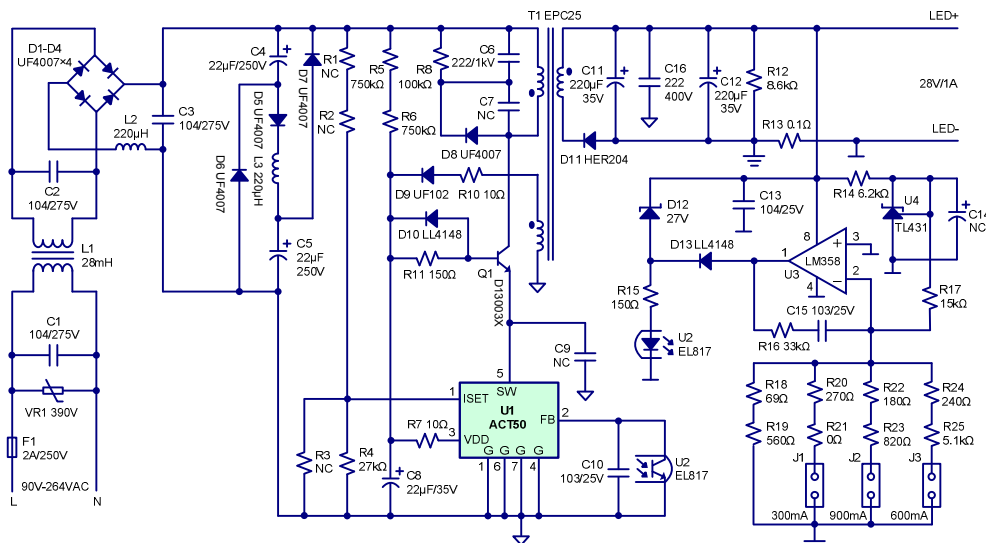

Bill of Materials

REF.	DESCRIPTION	MFTR.
U1	IC, ACT50UC-T, DIP-8	Active
U2	IC, EL817C, DIP-4	Everlight
U3	IC, LM358, DIP-8	Everlight
U4	IC, TL431, TO-92	USE
C1-C3	Capacitor-X2 0.1μF/275V 18×6×12×15mm	UTX
C4, C5	Capacitor, Electrolytic, 22μF/250V, 10×20mm	KSC
C6	Capacitor, Ceramic, 2200pF/1kV, DIP	POE
C8	Capacitor, Electrolytic, 22μF/35V, 5×11mm	KSC
C10	Capacitor, Ceramic, 0.1μF/25V	POE
C11,C12	Capacitor, Electrolytic, 220pF/35V, 8×12mm	KSC
C13	Mul-Cap Ceramic, 0.1μF/25V, DIP	POE
C15	Mul-Cap Ceramic, 0.01μF/25V, DIP	POE
C16	Safety Capacitor, Y2, 2200pF/400V, P = 10mm, DIP	UTX
D1-D8	Diode, Ultra Fast, UF4007, 1000V/1.0A, DO-41	Good-Ark
D9	Diode, Ultra Fast, UF102, 200V/1.0A, DO-41	PANJIT
D10,D13	Diode, Switching, 75V/150mA, LL4148 MINI-MELF	Good-Ark
D11	Diode, Schottky, HER204, 300V/2A, DO-15	ST
D12	Diode, Zener, GDZJ27D, 27V, 0.5W, DO-35	PANJIT
L1	Inductor, UU10.5, 28mH	
L2, L3	Axial Inductor, 220μH, 0410, DIP	Amode Tech
Q1	Transistor, NPN, 600V, 1.5A, D13003X, TO-220	Hua Wei
F1	Fuse: 2A 250V 3.6×10mm with Pigtail	Walter
R4	Meter Film Resistor, 27kΩ, 1/4W, 1%	TY-OHM
R5, R6	Carbon Film Resistor, 750kΩ, 1/4W, 5%	TY-OHM
R7	Carbon Film Resistor, 10Ω, 1/4W, 5%	TY-OHM
R8	Carbon Film Resistor, 100kΩ, 1W, 5%	TY-OHM
R10	Carbon Film Resistor, 10Ω, 1/2W, 5%	TY-OHM
R11, 15	Carbon Film Resistor, 150Ω, 1/4W, 5%	TY-OHM
R12	Carbon Film Resistor, 8.6kΩ, 1/4W, 5%	TY-OHM
R13	Meter Film Resistor, 0.1Ω, 1/4W, 1%	TY-OHM
R14	Carbon Film Resistor, 6.2kΩ, 1/4W, 5%	TY-OHM
R16	Carbon Film Resistor, 33kΩ, 1/4W, 5%	TY-OHM
R17	Carbon Film Resistor, 15kΩ, 1/4W, 5%	TY-OHM
R18	Carbon Film Resistor, 69Ω, 1/4W, 5%	TY-OHM
R19	Carbon Film Resistor, 560Ω, 1/4W, 5%	TY-OHM
R20	Carbon Film Resistor, 270Ω, 1/4W, 5%	TY-OHM
R21	Carbon Film Resistor, 0Ω, 1/4W, 5%	TY-OHM
R22	Carbon Film Resistor, 180Ω, 1/4W, 5%	TY-OHM
R23	Carbon Film Resistor, 820Ω, 1/4W, 5%	TY-OHM
R24	Carbon Film Resistor, 240Ω, 1/4W, 5%	TY-OHM
R25	Carbon Film Resistor, 5.1kΩ, 1/4W, 5%	TY-OHM
VR1	TVR07391KSY ϕ7, 390V ±10%	Thinking
T1	Transformer, L _p = 0.8mH, EPC25	TY-OHM

Build up

WINDING	TERMINAL		TURNS	WIRE			INSULATION	
	START	FINISH		TYPE	SIZE × QTY	LAYER	THICK/WIDE	LAYER
P1	3	1	87	2UEW	0.25Φ×1	1	25μ/8.5mm	2
SH1	1	Open	30	2UEW	0.15Φ×2	1	25μ/8.5mm	2
S1	10	11	28	TEXE	0.6Φ×1	1	25μ/8.5mm	2
SH2	6	Open	1.1	Copper	7mm	1	25μ/8.5mm	2
P2	5	6	14	2UEW	0.25Φ×1	1	25μ/8.5mm	2

P1 and P2 are Primary, S1 is Secondary (Bobbin: EPC25 Horizontal)

PCB Top and Bottom Layers

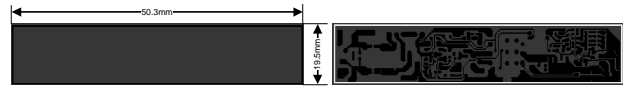

Transformer Specification

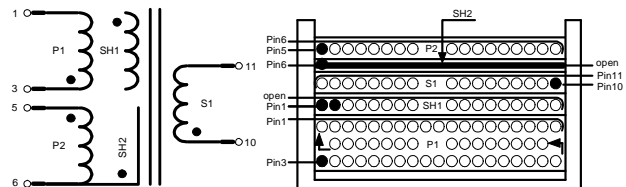

Electrical Specifications

ITEM	DESCRIPTION	CONDITION	LIMITS
1	Electrical Strength	50Hz, 1 minute, from Primary and Secondary	3kVAC
2	P1 Inductance	Inductance between pin 1 and pin 3 at 1VAC & 1kHz	0.8mH ±7%
3	P1 Leakage Inductance	Inductance between pin 1 and pin 3 with pins 5-6 and 10-11 shorted	75μH

Typical Performance Characteristics

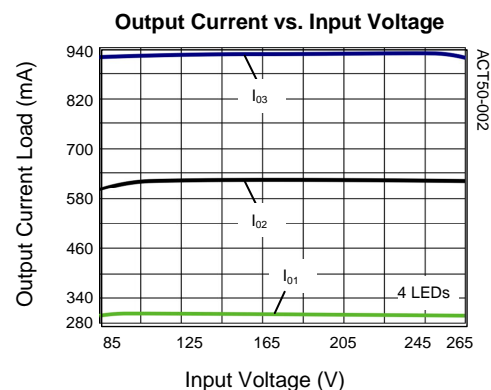
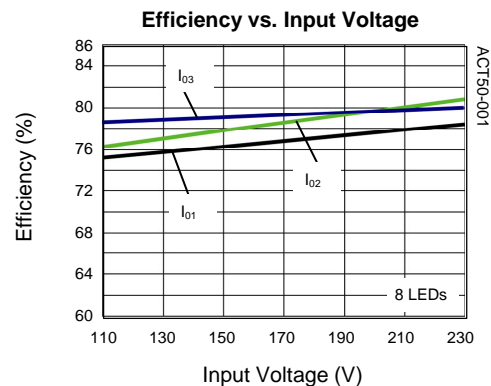

EVALUATION KITS	V _{IN}	I ₀	LED(s)
ACT50DH-LED08	85-264VAC	I ₀₁ 350mA±5%	7×300mA, or
		I ₀₂ 600mA±5%	7×600mA, or
		I ₀₃ 900mA±5%	7×900mA