

## FEATURES

- Over 90% Efficiency
- 10V to 600V Input Range
- Constant Current LED Driver
- Applications from a few mA to more than 1A output
- LED String From One to Hundreds of Diodes
- Linear and PWM Dimming Capability
- Input Voltage Surge Ratings up to 600V

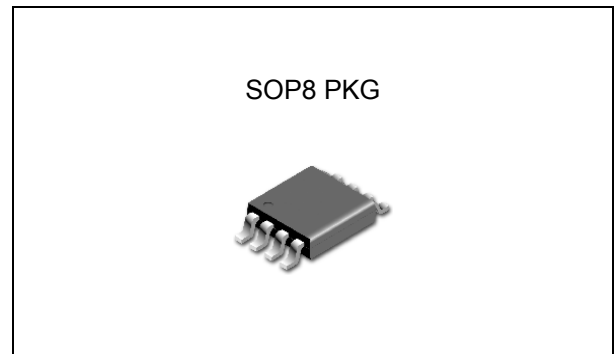

## APPLICATION

- DC/DC or AC/DC LED driver applications
- RGB backlighting LED driver
- Backlighting of flat panel displays
- General-purpose constant current source
- Signage and decorative LED lighting
- Automotive
- Chargers

## ORDERING INFORMATION

Device	Package
TJ9910D	SOP8

## DESCRIPTION

The TJ9910 is a PWM high-efficiency LED driver control IC. It allows efficient operation of high-brightness (HB) LEDs from voltage sources ranging from 10VDC up to 600VDC. TJ9910 controls an external MOSFET at fixed switching frequencies up to 300 kHz. The frequency can be programmed using a single resistor. The LED string is driven at a constant current rather than a constant voltage, thus providing a constant light output and an enhanced reliability. The output current can be programmed between a few milliamps and up to more than 1.0A. TJ9910 uses a rugged high-voltage junction isolated process that can withstand an input voltage surge up to 600V. The output current to a LED string can be programmed to any value between zero and its maximum value by applying an external control voltage at the linear dimming control input of TJ9910. TJ9910 provides a low-frequency PWM dimming input that can accept an external control signal with a duty ratio of 0-100% and a frequency of up to a few kHz.

## Absolute Maximum Ratings

CHARACTERISTIC	SYMBOL	MIN.	MAX.	UNIT
Supply voltage to GND	-	-0.5	600	V
CS, LD, PWM_D, GATE to GND	-	-0.3	V <sub>DD</sub> +0.3	V
Operating Temperature Range	-	-40	85	°C
Junction Temperature	T <sub>JOPR</sub>	125		°C
Storage Temperature Range	T <sub>STR</sub>	-65	150	°C

## Ordering Information

Package	Order No.	Description	Package Marking	Supplied As
SOP8	TJ9910D	LED Driver	TJ9910	Reel

## PIN CONFIGURATION

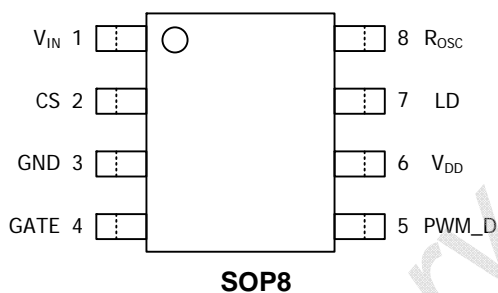

## PIN DESCRIPTION

Pin No.	Pin Name	Pin Function
1	V <sub>IN</sub>	Input Voltage
2	CS	Senses LED string current
3	GND	Ground
4	GATE	Drives the gate of external MOSFET
5	PWM_D	Low Frequency PWM Dimming pin, also Enable input. Internal 100kΩ pull-down to GND
6	V <sub>DD</sub>	Supply Voltage
7	LD	Linear Dimming by changing the current limit threshold at current sense comparator
8	R <sub>osc</sub>	Oscillator control. A resistor connected between this pin and ground sets the PWM frequency

## BLOCK DIAGRAM

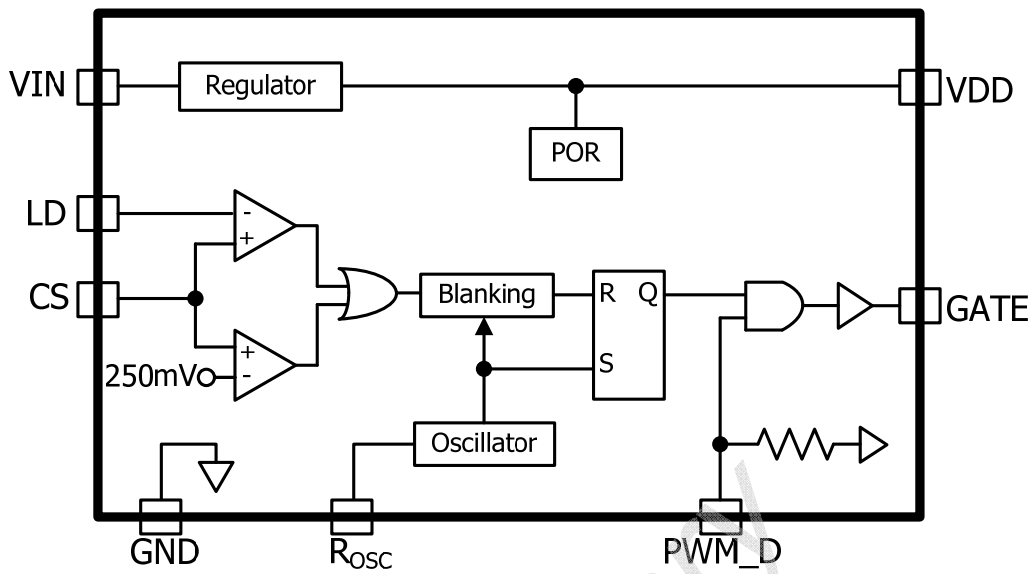

## Typical Application Circuit

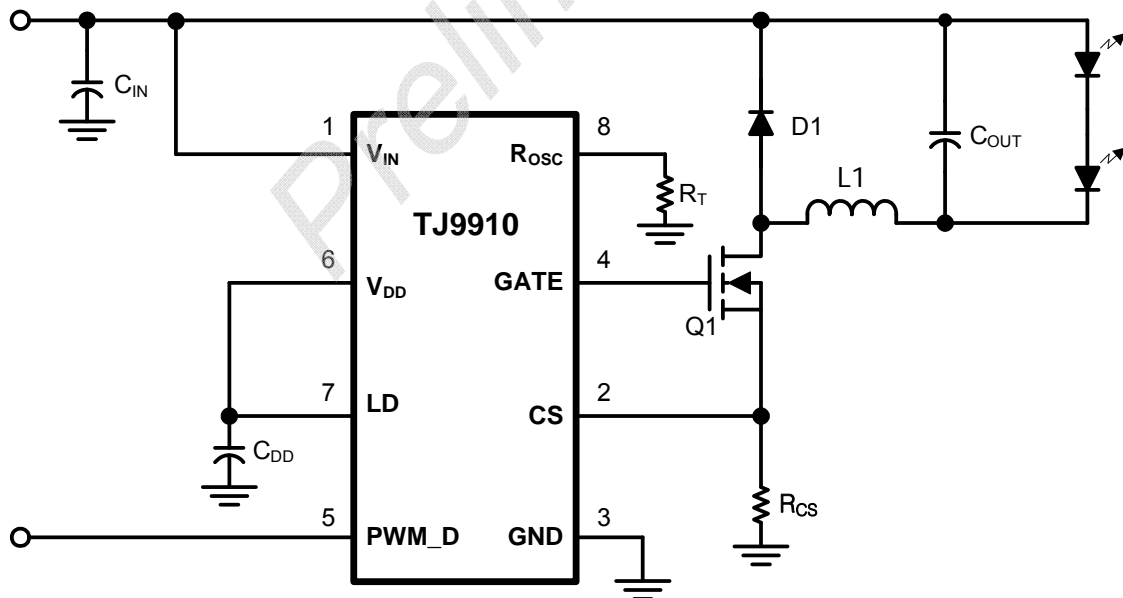

## ELECTRICAL CHARACTERISTICS

( $T_A = 25^\circ\text{C}$  unless otherwise specified)

PARAMETER	SYMBOL	TEST CONDITION	MIN.	TYP.	MAX.	UNIT
Input DC supply voltage range	$V_{\text{INDC}}^1$	DC Input Voltage	10		600	V
Shut-down mode supply current	$I_{\text{INSD}}$	Pin PWM_D to GND, $V_{\text{IN}} = 8\text{V}$	0.5		1	mA
Internally regulated voltage	$V_{\text{DD}}$	$V_{\text{IN}} = 10$ to 600V, $I_{\text{DD(EXT)}}=0$ , pin Gate open	7.0	7.5	8.0	V
Load regulation of $V_{\text{DD}}$	$\Delta V_{\text{DD}}$ , load	$I_{\text{DD(EXT)}} = 0$ to 1.0mA, 500pF at GATE $R_{\text{OSC}} = 226\text{k}\Omega$ , PWM_D = $V_{\text{DD}}$	0	-	100	mV
Maximal pin $V_{\text{DD}}$ voltage	$V_{\text{DD,max}}$	When an external voltage is applied to pin $V_{\text{DD}}$			10.0	V
$V_{\text{DD}}$ current available for external circuitry	$I_{\text{DD(EXT)}}$	$V_{\text{IN}} = 10$ to 100V			0.7	mA
$V_{\text{DD}}$ undervoltage lockout threshold	UVLO	$V_{\text{IN}}$ rising	6.45	6.7	6.95	V
$V_{\text{DD}}$ undervoltage lockout hysteresis	$\Delta\text{UVLO}$	$V_{\text{IN}}$ falling		500		mV
Pin PWM_D input low voltage	$V_{\text{EN(lo)}}$	$V_{\text{IN}} = 10$ to 600V			0.8	V
Pin PWM_D input high voltage	$V_{\text{EN(hi)}}$	$V_{\text{IN}} = 10$ to 600V	2.0			V
Pin PWM_D pull-down resistance	$R_{\text{EN}}$	$V_{\text{EN}} = 5\text{V}$	50	100	150	k $\Omega$
Current sense pull-in threshold voltage	$V_{\text{CS(hi)}}$	$T_A = -40^\circ\text{C}$ to $+85^\circ\text{C}$	225	250	275	mV
GATE high output voltage	$V_{\text{GATE(hi)}}$	$I_{\text{OUT}} = 10\text{mA}$	$V_{\text{DD}}-0.3$		$V_{\text{DD}}$	V
GATE low output voltage	$V_{\text{GATE(lo)}}$	$I_{\text{OUT}} = -10\text{mA}$	0		0.3	V
Oscillator frequency	$f_{\text{OSC}}$	$R_{\text{OSC}} = 1.00\text{M}\Omega$ $R_{\text{OSC}} = 226\text{k}\Omega$	20 80	25 100	30 120	kHz
Maximum Oscillator PWM Duty Cycle	$D_{\text{MAX hf}}$	$F_{\text{PWM hf}} = 25\text{kHz}$ , at GATE, CS to GND			100	%
Pin LD (Linear Dimming) voltage range	$V_{\text{LD}}$	$T_A = <85^\circ\text{C}$ , $V_{\text{IN}} = 12\text{V}$	0		250	mV
Current sense blanking interval	$T_{\text{BLANK}}$	$V_{\text{CS}} = 0.55V_{\text{LD}}$ , $V_{\text{LD}} = V_{\text{DD}}$	150	215	280	ns
Delay from CS to GATE lo	$t_{\text{DELAY}}$	$V_{\text{IN}} = 12\text{V}$ , $V_{\text{LD}} = 0.15$ , $V_{\text{CS}} = 0$ to 0.22V after $T_{\text{BLANK}}$			300	ns
GATE output rise time	$t_{\text{RISE}}$	$C_{\text{GATE}} = 500\text{pF}$ , $V_{\text{DD}} = 7.5\text{V}$	30		50	ns
GATE output fall time	$t_{\text{FALL}}$	$C_{\text{GATE}} = 500\text{pF}$ , $V_{\text{DD}} = 7.5\text{V}$	30		50	ns

Note 1. Also limited by package power dissipation limit, whichever is lower.

## APPLICATION INFORMATION

The TJ9910 is designed for wide range for lighting applications. When the gate signal enhances the external power MOSFET, the LED driver stores the input energy in an inductor and, deliver the energy directly to LEDs. The energy stored in the magnetic component is further delivered to the output during the OFF cycle of the power MOSFET producing current through the string of LEDs.

The gate drive is enabled when VDD is higher than UVLO threshold (6.7V, typical). The output current is then controlled by limiting the peak current in the external power MOSFET. This is done by a current sense resistor connected in series with the source terminal of the MOSFET. The voltage from the sense resistor is applied to the CS pin of the TJ9910. When the voltage at CS pin exceeds the threshold voltage, the gate drive terminates to turn off the power MOSFET. This threshold voltage is internally set to 250mV, or it can be programmed externally by applying voltage to the LD pin.

### Supply Current

A current of 1mA is required to start TJ9910, as shown in block diagram. In many cases, the TJ9910 can be continuously powered using its internal linear regulator which provides a regulated voltage of 7.5V, typical.

### Setting Light Output

The peak CS voltage is a good representation of the average current in LED. However, since there is difference between peak and average current, so such an error should be taken into account while selecting the value of this current sense resistor. For example: if the peak to peak ripple current in the inductor is 150mA, to get a 500mA LED current, the sense resistor should be  $250\text{mV}/(500\text{mA} + 0.5 \cdot 150\text{mA}) = 0.43\Omega$

### Dimming

Dimming can be accomplished by two ways, Linear or PWM dimming. The linear dimming is by changing the LED current linearly or by switching the current ON and OFF while maintaining it constant. PWM dimming controls the LED brightness by varying the duty ratio of the output current.

The linear dimming can be achieved by applying a control voltage from 0 to 250mV to the LD pin. This control voltage overrides the internally set 250mV threshold level of the CS pin and programs the output current accordingly. However, applying a control voltage higher than 250mV at the LD pin will not change the output current setting.

The PWM dimming can be achieved by an external PWM signal to the PWM\_D pin. The PWM signal can be generated by a microcontroller or a pulse generator with a duty cycle proportional to the amount of desired light output. This signal enables and disables the converter modulating the LED current in the PWM fashion. In this mode, LED current can be in one of the two states: zero or the nominal current set by the current sense resistor. By using the PWM control method, the light output can be adjusted between zero and 100%. The accuracy of the PWM dimming method is limited only by the minimum gate pulse width, which is a fraction of a percent of the low frequency duty cycle.

## Inductor Selection

For the given assumptions, the ideal inductor is calculated as

$$L = \frac{(V_{IN} - V_{LEDS}) \cdot T_{ON}}{0.3 \cdot I_{LED}}$$

Where

$V_{IN} = 110V \times 1.414 = 155.5V$ , for the normal rectified input voltage, and,

$I_{LED}$  is 350mA as a typical current level of normal LED's, and

$V_{LED}$  is 3.0V as typical forward voltage of normal LED's, and

$T_{ON}$  is defined:

$$T_{ON} = \frac{\text{Duty}}{f_{OSC}}$$

And Duty is defined as:

$$\text{Duty} = \frac{V_{LEDS}}{V_{IN}} = \frac{30V}{155V} = 19.3\%$$

Then

$$T_{ON} = \frac{0.193}{50K} = 3.86\mu s$$

Then

$$L = \frac{(V_{IN} - V_{LEDS}) \cdot T_{ON}}{0.3 \cdot I_{LED}} = \frac{(155V - 30V) \cdot 3.86\mu s}{0.3 \cdot 350mA} = 4.59mH$$

## Input Bulk Capacitor

An input filter capacitor is required to hold the rectified AC voltage above twice the LED string voltage throughout the AC line cycle. Assuming 15% relative voltage ripple across the capacitor, a simplified formula for the minimum value of the bulk input capacitor is given by:

$$C_{MIN} = \frac{I_{LED} \cdot V_{LED} \cdot 0.06}{V_{IN}^2}$$

$$C_{MIN} = 22\mu F, \text{ a value } 22\mu F/250V \text{ can be used.}$$

## Enable

The TJ9910 can be turned off by pulling the PWM\_D pin to ground. When disabled, the product draws quiescent current of less than 1mA.

## Output Open Circuit Protection

When the buck topology is used, and the LED is connected in series with the inductor, there is no need for any protection against an open circuit condition in the LED string. Open LED connection means no switching and can be continuous. However, in the case of the buck-boost or the Flyback topology the TJ9910 may cause excessive voltage stress of the switching transistor and the rectifier diode and potential failure. In this case, the TJ9910 can be disabled by pulling the PMW\_D pin to ground when the over voltage condition is detected.

## REVISION NOTICE

The information in this datasheet can be revised without any notice to describe proper electrical characteristics.

Preliminary