

AP8022

Chipown

GREEN POWER OFF LINE SMPS PRIMARY SWITCHER

Features

- 85v to 265v wide range AC voltage input
- A 730v MOSFET on the same silicon chip
- Auto start up with high voltage current source
- PWM with current mode control
- 10v to 39v wide range VCC voltage
- Fixed 55KHz switching frequency
- Automatic skip cycle mode in low load condition.
- Over temperature, over current and over voltage protection
- Auxiliary under voltage lockout with hysteresis

- Electromagnetic Oven power supplies
- Air Conditioner power supplies
- STB power supplies
- AC/DC LED Driver Applications

Package

- SOP8 & DIP8

Type	SOP8	DIP8
European (195-265 Vac)	12W	20W
US (85-265 Vac)	7 W	12W

Applications

- Power AC/DC Adapters for Chargers
- DVD/VCD power supplies

Typical Application

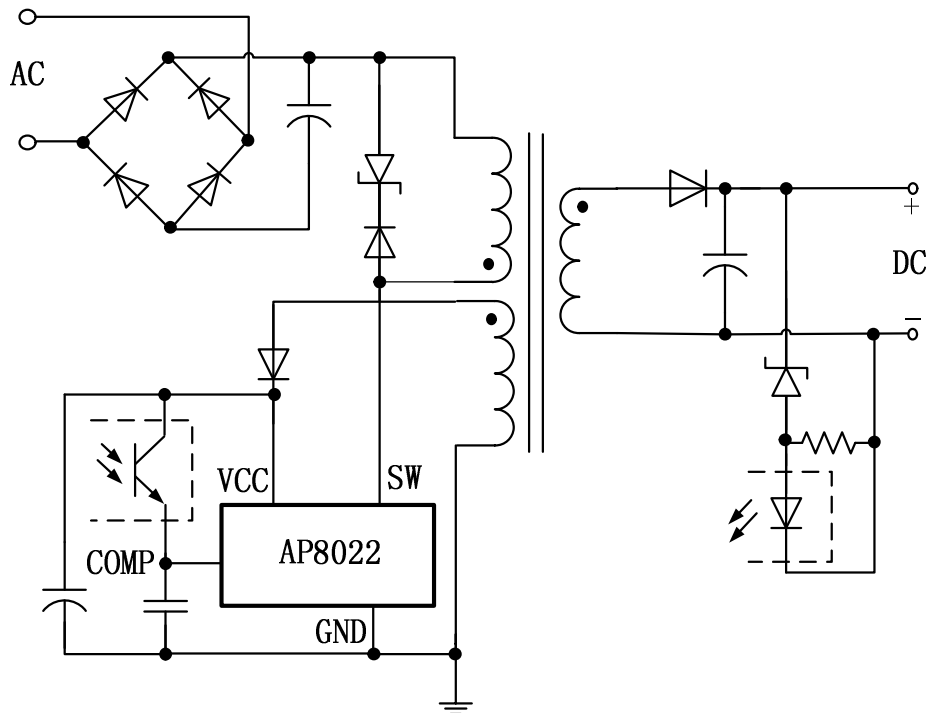

Pin Configuration

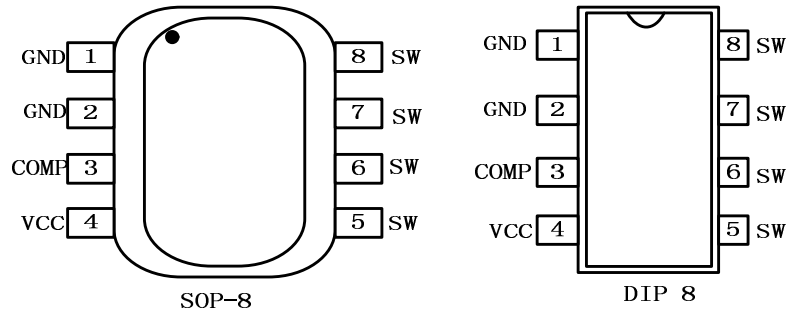

Pin Definitions

Pin Number	Pin Name	Pin Function Description
1,2	GND	Sense FET source terminal on primary side and internal control ground.
3	COMP	Feedback input defines the peak drain MOSFET current.
4	VCC	Positive supply voltage input. Although connected to an auxiliary transformer winding, current is supplied from SW via an internal switch during startup (see Internal Block Diagram section). It is not until VCC reaches them UVLO upper threshold (15.5V) that the internal start-up switch opens and device power is supplied via the auxiliary transformer winding.
5,6,7,8	SW	The SW pin is designed to connect directly to the primary lead of the transformer and is capable of switching a maximum of 700V.

Internal Block Diagram

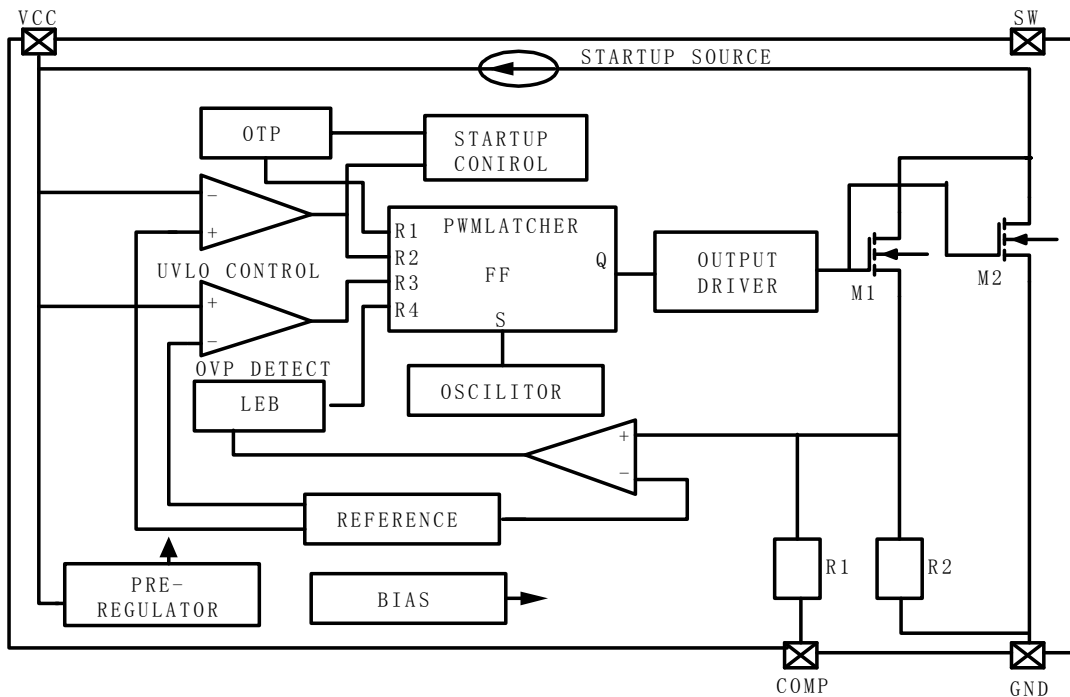

Absolute Maximum Ratings

($T_a=25^{\circ}\text{C}$, unless otherwise specified)

Symbol	Parameter	Value	Unit
V_{SW}	SW to GND Voltage ($T_j=25\text{-}125^{\circ}\text{C}$)	-0.3 ... 730	V
I_{D}	Continuous VDMOS Drain Current	Internally limited	A
VCC	Supply Voltage	0...50	V
I_{COMP}	Feedback Current	3	mA
V_{ESDMM}	Electrostatic Discharge: Machine Model (($R=0\Omega$; $C=200\text{pF}$))	200	V
V_{ESDHBM}	Electrostatic Discharge: HBM	2000	V
T_j	Junction Operating Temperature	Internally limited	$^{\circ}\text{C}$
T_c	Case Operating Temperature	-40 to 150	$^{\circ}\text{C}$
T_{stg}	Storage Temperature	-55 to 150	$^{\circ}\text{C}$

Electrical Characteristic (Power)

Symbol	Parameter	Condition	Min.	Typ.	Max.	Unit
BV_{DSS}	VDMOS Breakdown Voltage	$I_{\text{D}}=1\text{mA}$; $V_{\text{COMP}}=2\text{V}$	730	750		V
I_{DSS}	Zero Gate Voltage Drain Current	$V_{\text{DS}}=500\text{V}$; $V_{\text{COMP}}=2\text{V}$;			100	μA
$R_{\text{DS(on)}}$	Static Drain-Source on Resistance	$V_{\text{GS}}=10\text{V}$ $I_{\text{D}}=0.4\text{A}$;		15	17	Ω
T_{r}	Rise Time	$I_{\text{D}}=0.1\text{A}$; $V_{\text{IN}}=300\text{V}$		50		ns
T_{f}	Fall Time	$I_{\text{D}}=0.2\text{A}$; $V_{\text{IN}}=300\text{V}$		100		
C_{OSS}	VDMOS Drain Capacitance	$V_{\text{DS}}=25\text{V}$		40		pF

Electrical Characteristic (Control)

($T_a=25^\circ\text{C}$, $V_{CC}=18\text{V}$, unless otherwise specified)

Symbol	Parameter	Condition	Min.	Typ.	Max.	Unit
UVLO SECTION						
V_{START}	VCC Start Threshold Voltage	$V_{COMP}=0\text{V}$	14	15.5	17	V
V_{STOP}	VCC Stop Threshold Voltage	$V_{COMP}=0\text{V}$	8	9	10	V
V_{HYS}	VCC Threshold Hysteresis		5.8	6.5	7.2	V
OSCILLATOR SECTION						
F_{OSC}	Initial Accuracy	$V_{STOP}\leq V_{CC}\leq 35\text{V}$; $0\leq T_j\leq 100^\circ\text{C}$	48	55	62	kHz
$\Delta F/\Delta T$	Frequency Change With Temperature	$-25^\circ\text{C}\leq T_j\leq +85^\circ\text{C}$		± 5	± 10	%
FEEDBACK SECTION						
I_{COMP}	Feedback Shutdown Current	$T_j=25^\circ\text{C}$, $V_{COMP}=0\text{V}$		0.9		mA
R_{COMP}	COMP Pin Input Impedance	$I_D=0\text{mA}$		1.4		k Ω
CURRENT LIMIT(SELF-PROTECTION)SECTION						
G_{ID}	I_{COMP} to I_D Current Gain			560		
I_{LIM}	Peak Current Limit	$T_j=25^\circ\text{C}$	0.56	0.70	0.84	A
T_D	Current Sense Delay to Turn-Off	$I_D=0.2\text{A}$			200	ns
T_B	Blanking Time				500	ns
T_{ONMIN}	Minimum Turn On Time				700	ns
PROTECTION SECTION						
T_{SD}	Thermal Shutdown Temperature		140	170	-	$^\circ\text{C}$
T_{HYST}	Thermal Shutdown Hysteresis			40		$^\circ\text{C}$
V_{OVP}	Over Voltage Protection		39	43	47	V
SUPPLY CURRENT SECTION						
I_{CH}	Startup Charging Current			-1		mA
I_{CHOFF}	Start Up Charging Current in Thermal Shutdown	$V_{CC}=5\text{V}$; $V_{DS}=100\text{V}$ $T_j>T_{SD}$			0.2	mA
I_{OP0}	Operating Supply Current (Control Part Only) Switching	$V_{COMP}=0\text{V}$		4		mA
I_{OP1}	Operating Supply Current (Control Part Only) Not Switching	$V_{COMP}=2\text{V}$		2.6	5	mA

Functional Description

Startup

This device includes a high voltage start up current source connected on the SW of the device. As soon as a voltage is applied on the input of the converter, this start up current source is activated and to charge the VCC capacitor as long as VCC is lower than VSTART. When reaching VSTART, the start up current source is cut off by UVLO&TSD and the device begins to operate by turning on and off its main power MOSFET. As the COMP pin does not receive any current from the opto-coupler, the device operates at full current capacity and the output voltage rises until reaching the regulation point where the secondary loop begins to send a current in the opto-coupler. At this point, the converter enters a regulated operation where the COMP pin receives the amount of current needed to deliver the right power on secondary side.

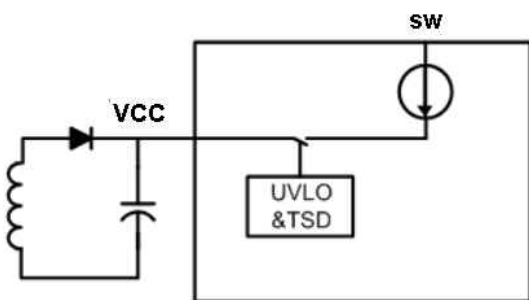

Fig 1 Startup circuit

Feedback

A feedback pin controls the operation of the device. Unlike conventional PWM control circuits which use a voltage input, the COMP pin is sensitive to current. Figure 2 presents the internal current mode structure. The Power MOSFET delivers a sense current which is proportional to the main current. R2 receives this current

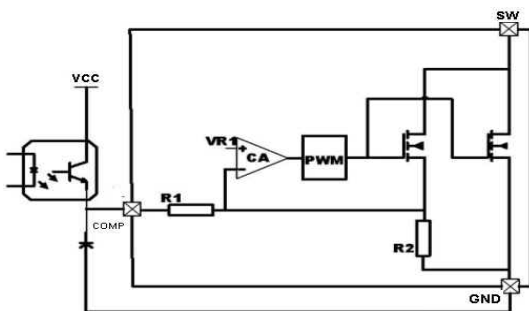

Fig 2 Feedback circuit

and the current coming from the COMP pin. The voltage across R2 VR2 is then compared to a fixed reference voltage. The MOSFET is switched off when VR2 equals the reference voltage.

Leading Edge Blanking (LEB)

At the instant the internal Sense FET is turned on, there usually exists a high current spike through the Sense FET, caused by the primary side capacitance and secondary side rectifier diode reverse recovery. Excessive voltage across the sense resistor would lead to false feedback operation in the current mode PWM control. To counter this effect, the device employs a leading edge blanking (LEB) circuit. This circuit inhibits the PWM comparator for a short time (typically 500ns) after the Sense FET is turned on.

Under Voltage Lock Out

Once fault condition occurs, switching is terminated and the Sense FET remains off. This causes VCC to fall. When VCC reaches the UVLO stop voltage, 9V, the protection is reset and the internal high voltage current source charges the VCC capacitor. When VCC reaches the UVLO start voltage, 15.5V, the device resumes its normal operation. In this manner, the auto-restart can alternately enable and disable the switching of the power Sense FET until the fault condition is eliminated.

Thermal Shutdown (TSD)

The Sense FET and the control IC are integrated in the same chip, making it easier for the control IC to detect the temperature of the Sense FET. When the temperature exceeds approximately 170°C, thermal shutdown is activated, the device turn off the Sense FET and the high voltage current source to charge VCC. The device will go back to work when the lower threshold temperature about 140°C is reached.

Over Voltage Protection (OVP)

In case of malfunction in the secondary side feedback circuit, or feedback loop open caused by a defect of solder, the current through the opto-coupler transistor becomes almost zero. Because excess energy is provided to the output, the output voltage may exceed the rated

AP8022

Package Dimensions (DIP8)

Size symbol	Min(mm)	Max(min)	Size symbol	Min(mm)	Max(min)
A	9.30	9.50	C2	0.50	
A1	1.524		C3	3.3	
A2	0.39	0.53	C4	1.57TYP	
A3	2.54		D	8.2	8.8
A4	0.66TYP		D1	0.2	0.35
A5	0.99TYP		D2	7.62	7.87
B	6.3	6.5	θ1	8°TYP	
C	7.2		θ2	8°TYP	
C1	3.3	3.5	θ3	5°TYP	

