

ALJ13007 TRANSISTOR (NPN)

FEATURES

power switching applications

MAXIMUM RATINGS ($T_A=25^{\circ}\text{C}$ unless otherwise noted)

Symbol	Parameter	Value	Units
V_{CBO}	Collector-Base Voltage	700	V
V_{CEO}	Collector-Emitter Voltage	400	V
V_{EBO}	Emitter-Base Voltage	9	V
I_C	Collector Current -Continuous	8	A
P_C	Collector Power Dissipation	2	W
T_J	Junction Temperature	150	$^{\circ}\text{C}$
T_{stg}	Storage Temperature	-55-150	$^{\circ}\text{C}$

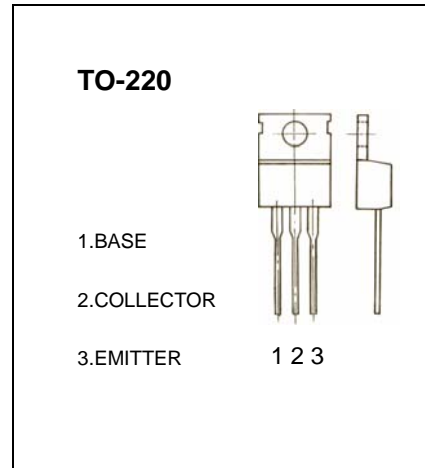

ELECTRICAL CHARACTERISTICS ($T_{amb}=25^{\circ}\text{C}$ unless otherwise specified)

Parameter	Symbol	Test conditions	MIN	TYP	MAX	UNIT
Collector-base breakdown voltage	$V_{(BR)CBO}$	$I_C=1\text{mA}, I_E=0$	700			V
Collector-emitter breakdown voltage	$V_{(BR)CEO}$	$I_C=10\text{mA}, I_B=0$	400			V
Emitter-base breakdown voltage	$V_{(BR)EBO}$	$I_E=1\text{mA}, I_C=0$	9			V
Collector cut-off current	I_{CBO}	$V_{CB}=700\text{V}, I_E=0$			1	mA
Collector cut-off current	I_{CEO}	$V_{CE}=400\text{V}, I_B=0$			100	μA
Emitter cut-off current	I_{EBO}	$V_{EB}=9\text{V}, I_C=0$			100	μA
DC current gain	h_{FE1}	$V_{CE}=5\text{V}, I_C=2\text{A}$	8		40	
	h_{FE2}	$V_{CE}=5\text{V}, I_C=5\text{A}$	5		30	
Collector-emitter saturation voltage	$V_{CE(sat)}$	$I_C=2\text{A}, I_B=0.4\text{A}$			1	V
		$I_C=5\text{A}, I_B=1\text{A}$			2	
		$I_C=8\text{A}, I_B=2\text{A}$			3	
Base-emitter saturation voltage	$V_{BE(sat)}$	$I_C=2\text{A}, I_B=0.4\text{A}$			1.2	V
		$I_C=5\text{A}, I_B=1\text{A}$			1.6	
Transition frequency	f_T	$I_C=500\text{mA}, V_{CE}=10\text{V}, f=1\text{MHz}$	4			MHz
Collector output capacitance	C_{ob}	$V_{CE}=10\text{V}, I_E=0, f=0.1\text{MHz}$		80		pF
Fall time	t_f	$V_{CC}=125\text{V}, I_C=5\text{A}$ $I_{B1}=-I_{B2}=1\text{A}$			0.7	μs
Storage time	t_s	$I_C=0.5\text{A}$	2.7		7.7	μs

CLASSIFICATION OF $h_{FE(1)}$

Rank						
Range	8-15	15-20	20-25	25-30	30-35	35-40