



iW1710-01 for 9V2A Adapter Design

General Design Specification :

1. AC Input Range 90-264Vac
2. DC Output 9V, 2A
3. Meet **"EPA_2.0"** Requirement with 20AWG/1.8m DC-Cable
4. Max Ripple <math><180\text{mV}_{P_P}</math>

1. Specification

Description	Symbol	Min	Typ	Max	Units	Comment
Input						
Voltage	V_{IN}	90		264	V _{AC}	2 Wire
Frequency	f_{LINE}	47	50/60	63	Hz	
No-load Input Power (230V _{AC})				0.3	W	
Output						
Output Voltage	V_{OUT}	8.55	9	9.45	V	Measured at the end of Cable(20AWG,1.8M)
Output Current	I_{OUT}	0		2	A	
Output Ripple Voltage	V_{RIPPLE}			180	mV _{P-P}	Measured at the End of DC Output cable $I_{OUT}=3A$ @20 MHz Bandwidth
Total Output Power						
Continuous Output Power	P_{OUT}			18	W	
Over Current Protection	I_{OUT_OCP}			3	A	Auto-restart
Efficiency	η	80.3			%	Measured at end of PCB, $V_{IN} = 115V_{AC}$ and 230Vac, $I_{OUT} = 3A$. ($T_A = 25^\circ C$)
Environmental						
Conducted EMI		Meets CISPR22B / EN55022B				
Safety		Designed to meet IEC60950, UL60950 Class II				
Ambient Temperature	T_{AMB}	0		40	° C	Free convection, sea level

2.Schematic Circuit

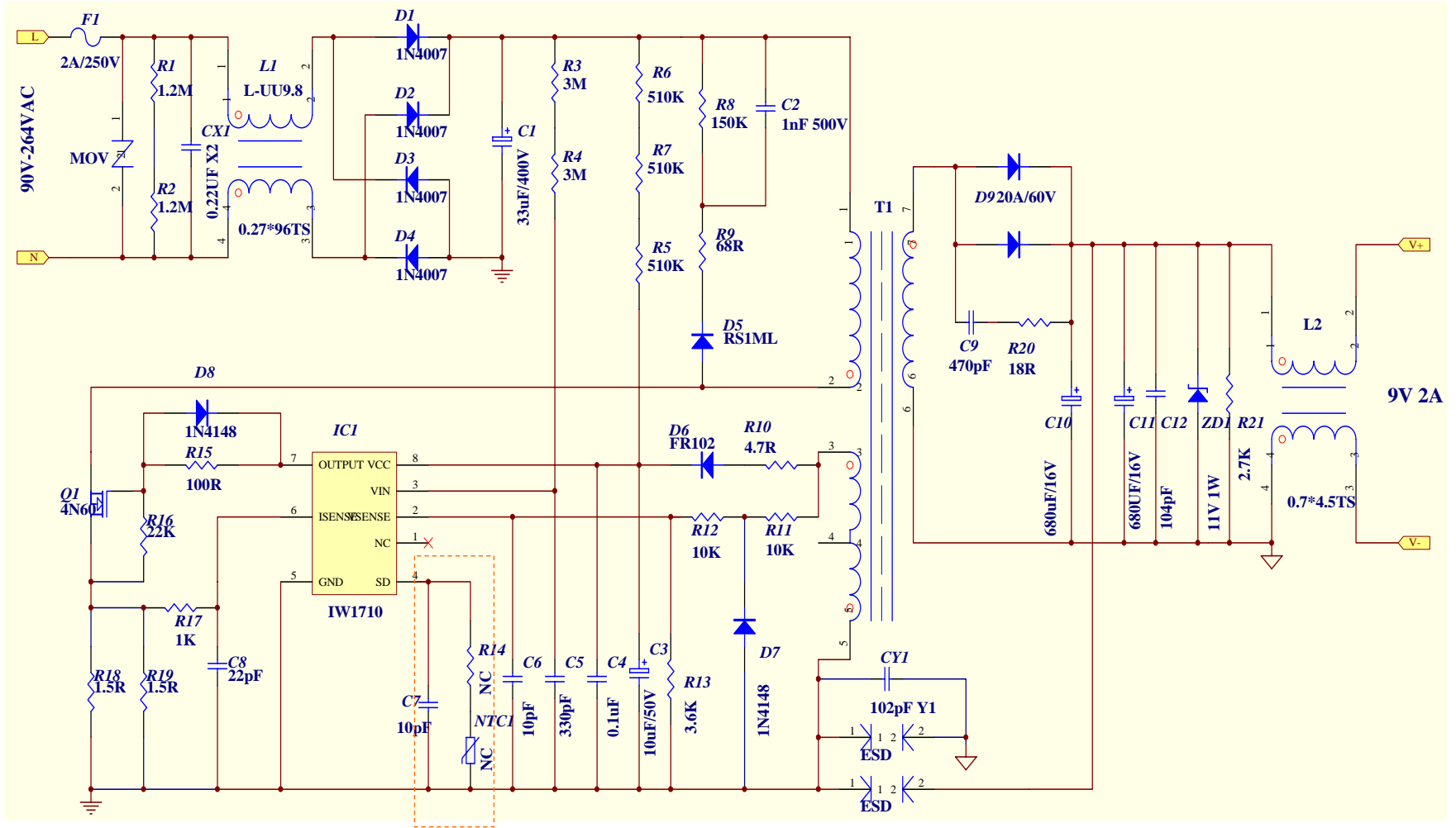

Optional:
OVP and OTP circuit

3. Option Circuit for OTP&OVP

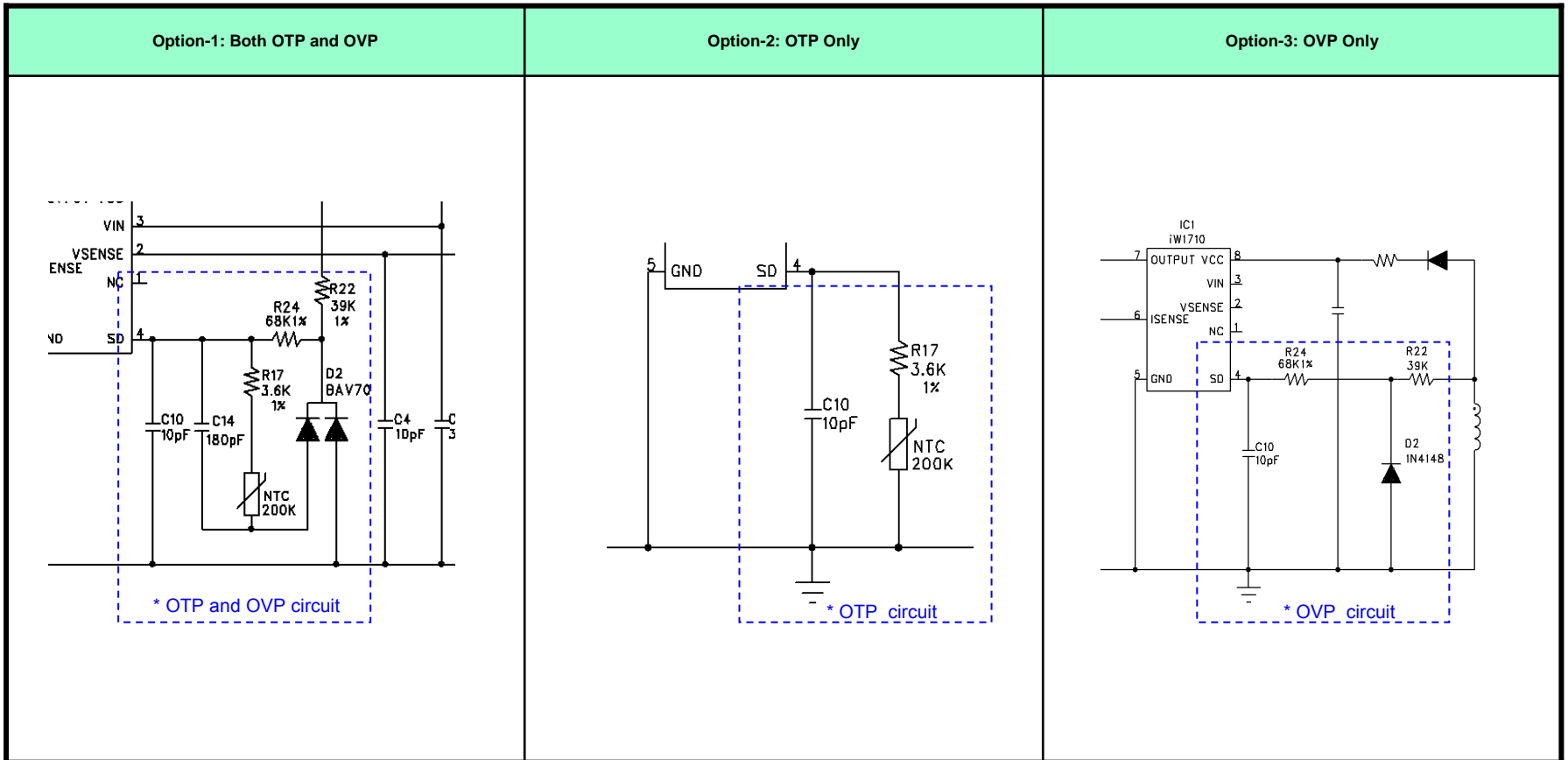

4. Circuit Board Photograph

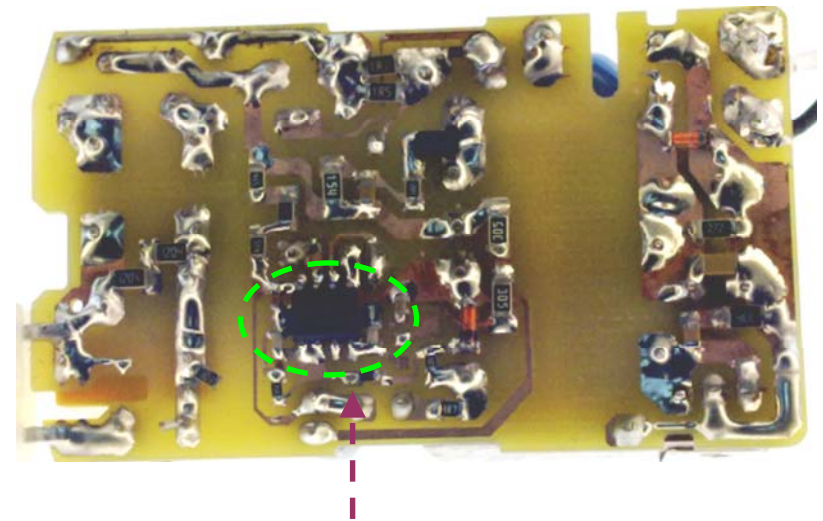
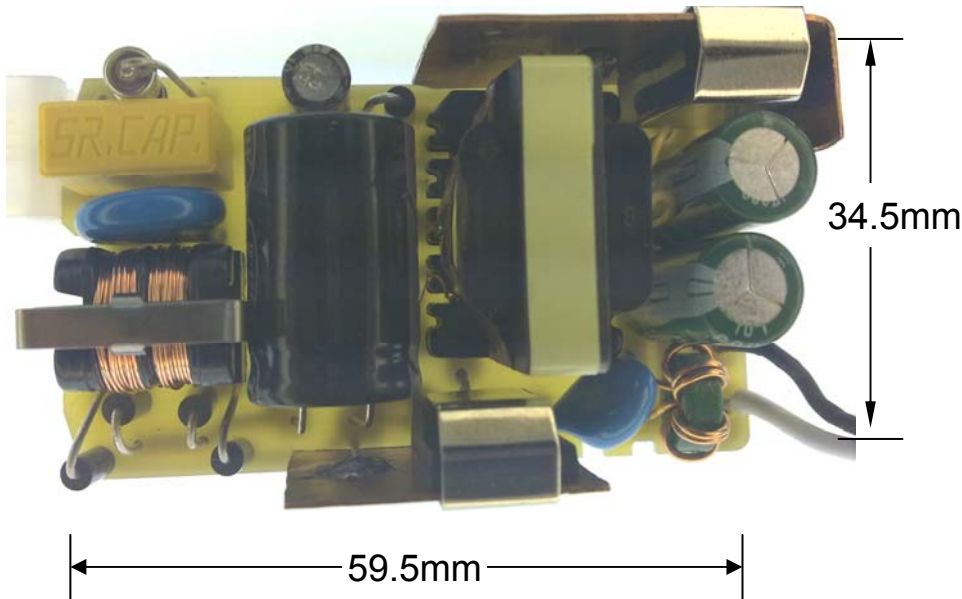

Primary Side QR Mode Controller iW1710-01

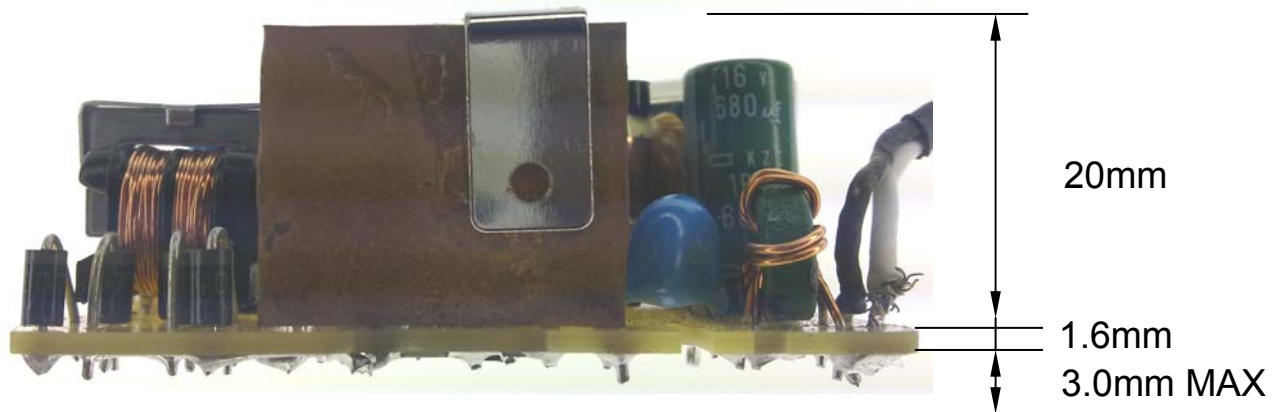

5. Bill of Material

Item	Qty.	Ref.	Description
1	1	IC1	iW1710-01, Off-line digital QR Mode Controller, SO-8
2	1	C1	33uF, 400V, E-CAP 13x21
3	1	C2	1nF,500V, SMD-0805
4	1	C3	10uF,50V,E-CAP,5x11.5, low ESR
5	1	C4	0.1uF,25V, SMD-0603
6	1	C5	330pF,25V, SMD-0603
7	1	C6	10pF,25V, SMD-0603
8	1	C7	10pF,25V, SMD-0603
9	1	C8	22pF,25V, SMD-0603
10	1	C9	470pF, 100V, SMD-0805
11	1	C10.C11	680uF 16V,8x20,low ESR
12	2	C12	104pF,25V, SMD-1206
13	1	CX1	0.22uF, 275V,X2
14	1	CY1	Y-CAP, 1nF,Y1
15	4	D1,D2,D3,D4	1N4007, Rectifier Diode DO-41
16	1	D5	RS1ML, Fast Rectifier Diode, SMD
17	1	D6	FR102, Fast Rectifier Diode DO-41
18	2	D7,D8	1N4148, Fast Rectifier Diode LL-34
19	1	D9	Y2060DN, schottcky, TO-220
20	1	F1	2A/250V, Fuse
21	1	L1	UU9.8, 15mH,CM-chock Inductor,
22	1	L2	150uH,CM-chock Inductor,T8.5X4.5X3

Item	Qty.	Ref.	Description
23	1	ZD1	11V 1W 5%
24	1	Q1	STB4NK60, 4A/600V, MOSFET, TO-220
25	2	R1,R2	1.2M Ω \pm 5%, SMD-1206
26	1	R3	3.0M Ω \pm 5%, SMD-1206
27	1	R4	3.0M Ω \pm 5%, SMD-1206
28	3	R5,R6,R7	510K Ω \pm 5%, SMD-0805
29	1	R8	150K Ω \pm 5%, SMD-1206
30	1	R9	68 Ω \pm 5%, SMD-1206
31	1	R10	4.7 Ω \pm 5%, SMD-0805
32	1	R11	10K Ω \pm 1%, SMD-0805
33	1	R12	10K Ω \pm 1%, SMD-0603
34	1	R13	3.6K \pm 1%, SMD-0603
35	1	R14	NC
36	1	R15	10 Ω \pm 5%, 1/8W
37	1	R16	22K Ω \pm 5%, SMD-0603
38	1	R17	1K Ω \pm 5%, 1/8W
39	2	R18,R19	1.5 Ω \pm 1%, SMD-1206
40	1	R20	18 Ω \pm 5%, SMD-0805
41	1	R21	2.7K Ω \pm 5%, SMD-1206
42	1	T1	EE22, Transformer
43	1	PCB	single side PCB, 94V0

6. Transformer Drawing

SCHEMATIC

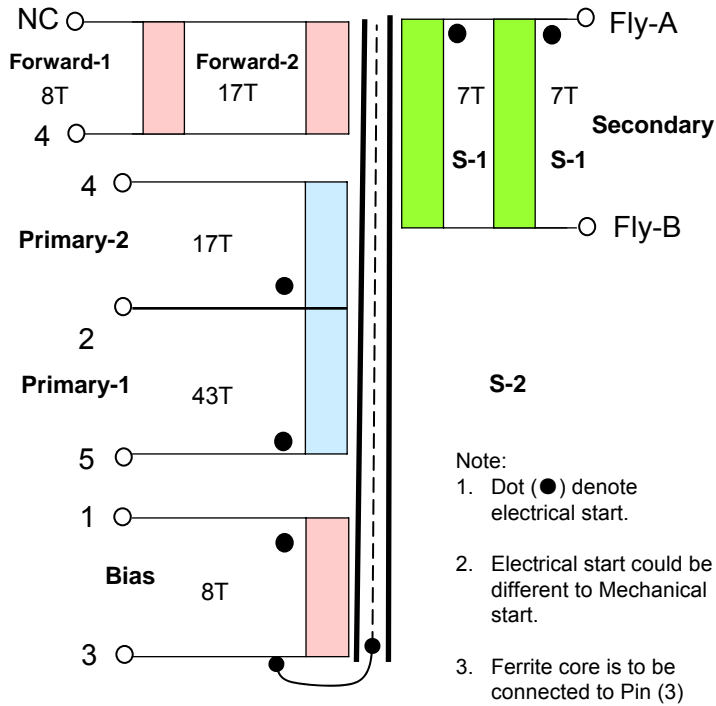

ELECTRICAL SPECIFICATIONS:

- Primary Inductance (L_p) = 580uH \pm 7% @10KHz
- Electrical Strength = 3KV, 50/60Hz, 1Min(pins 1~5 to pins A~B)

MATERIALS:

- Core : EE22(Ferrite Material TDK PC40 or equivalent)
- Bobbin : EE22 Vertical
- Magnet Wires : Type 2-UEW
- Layer Insulation Tape :3M1298 or equivalent.

FINISHED :

- Varnish the complete assembly

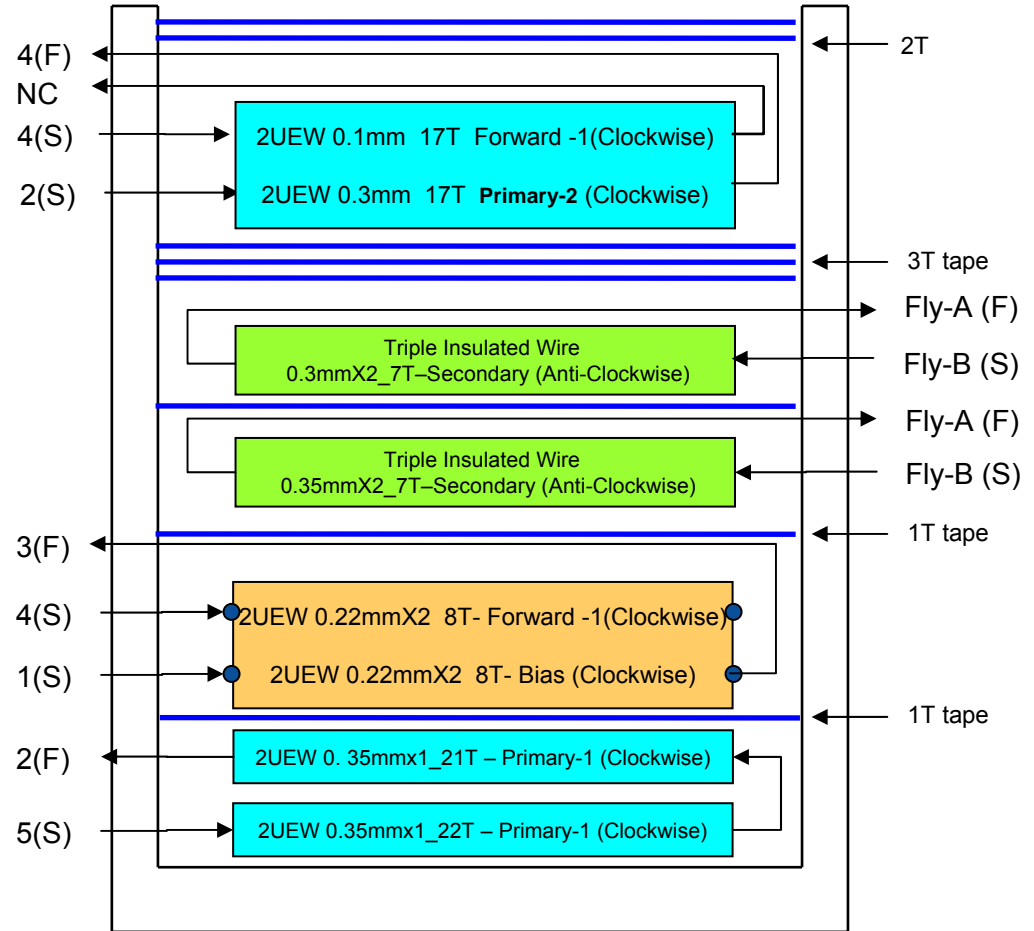

7. Regulation, Ripple and Efficiency Measurement

Spec.	Vout (V) : 9		Iout (mA) 2000				OCP (A)	Average η (%)	EPA2.0 η (%)
V _{IN} (V _{AC})	P _{IN} (W)	V _{OUT} (V)	I _{OUT} (A)	V _{RIPPLE} (mV _{P-P})	P _{OUT} (W)	η (%)			
90	0.080	9.02	0.00	18			2.590	85.42	
	5.270	9.00	0.50	32	4.50	85.39			
	10.470	9.01	1.00	32	9.01	86.06			
	15.730	9.01	1.50	54	13.52	85.92			
	21.370	9.01	2.00	110	18.02	84.32			
115	0.090	9.02	0.00	18			2.570	86.24	80.30
	5.270	9.00	0.50	30	4.50	85.39			
	10.440	9.00	1.00	30	9.00	86.21			
	15.540	9.01	1.50	40	13.52	86.97			
	20.860	9.01	2.00	50	18.02	86.39			
230	0.190	9.03	0.00	20			2.370	84.94	
	5.400	9.00	0.50	44	4.50	83.33			
	10.660	9.00	1.00	34	9.00	84.43			
	15.740	9.01	1.50	38	13.52	85.86			
	20.920	9.01	2.00	46	18.02	86.14			
264	0.240	9.02	0.00	22			2.280	83.90	
	5.480	9.00	0.50	42	4.50	82.12			
	10.830	9.00	1.00	34	9.00	83.10			
	15.920	9.01	1.50	38	13.52	84.89			
	21.100	9.02	2.00	52	18.04	85.50			

Note: Output voltage measured at end of PCB

8. EPA_2.0 Requirement

Table 1: Energy-Efficiency Criteria for Ac-Ac and Ac-Dc External Power Supplies in Active Mode: **Standard Models**

Nameplate Output Power (P _{no})	Minimum Average Efficiency in Active Mode (expressed as a decimal) ²
0 to ≤ 1 watt	≥ 0.480 * P _{no} + 0.140
> 1 to ≤ 49 watts	≥ [0.0626 * Ln (P _{no})] + 0.622
> 49 watts	≥ 0.870

Table 2: Energy-Efficiency Criteria for Ac-Ac and Ac-Dc External Power Supplies in Active Mode: **Low Voltage Models**

Nameplate Output Power (P _{no})	Minimum Average Efficiency in Active Mode (expressed as a decimal) ²
0 to ≤ 1 watt	≥ 0.497 * P _{no} + 0.067
> 1 to ≤ 49 watts	≥ [0.0750 * Ln (P _{no})] + 0.561
> 49 watts	≥ 0.860

EPA2.0 (Final) for Standard Models (P_{no}=18W) :

V _{IN} (VAC)	I _{OUT} (mA)	P _{IN} (W)	Measure at end of PCB				Measure at end of Cable (20AWG/1.8m, R _{Cable} =0.15Ω)			
			V _{OUT_PCB} (V)	P _{OUT_PCB} (W)	EFF _{PCB} (%)	AV-EFF _{PCB} (%)	V _{OUT_Cable} (V)	P _{OUT_Cable} (W)	EFF _{Cable} (%)	AV-EFF _{Cable} (%)
115	0.50	5.27	9.00	4.50	85.39	86.24	8.93	4.46	84.68	84.44
	1.00	10.44	9.00	9.00	86.21		8.85	8.85	84.77	
	1.50	15.54	9.01	13.52	86.97		8.79	13.18	84.80	
	2.00	20.86	9.01	18.02	86.39		8.71	17.42	83.51	
230	0.50	5.40	9.00	4.50	83.33	84.94	8.93	4.46	82.64	83.16
	1.00	10.66	9.00	9.00	84.43		8.85	8.85	83.02	
	1.50	15.74	9.01	13.52	85.86		8.79	13.18	83.72	
	2.00	20.92	9.01	18.02	86.14		8.71	17.42	83.27	

9. Output VI Characteristics

* Note: Output voltage is measured at end of PCB

$V_{IN}=90Vac/50Hz$

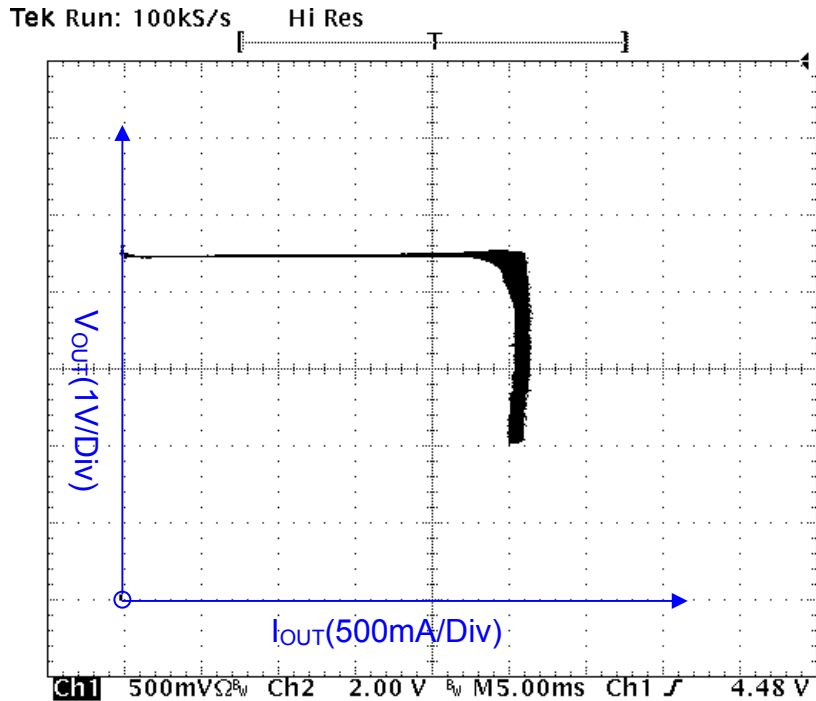

$V_{IN}=264Vac/50Hz$

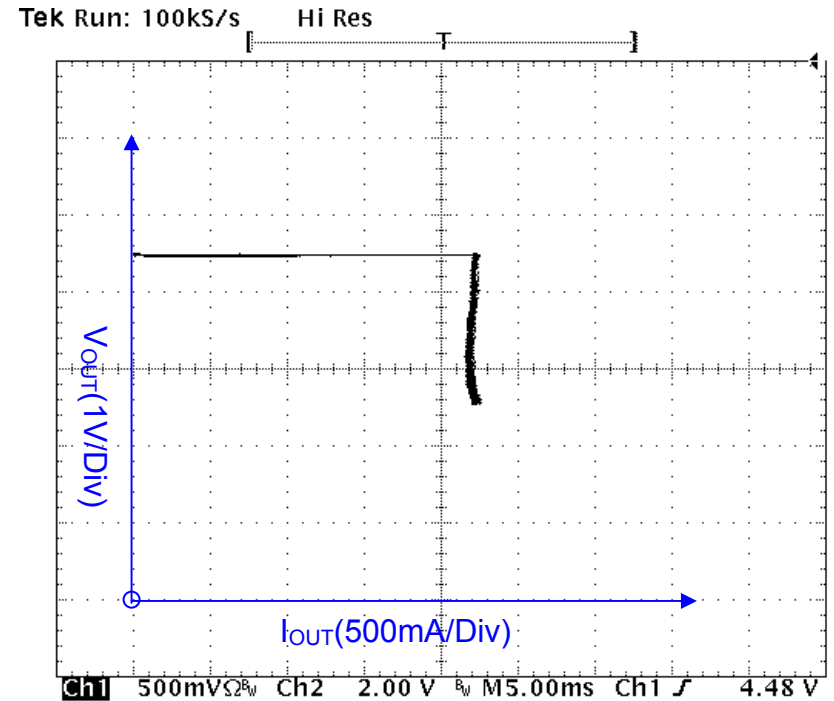

10. Turn On Delay Time

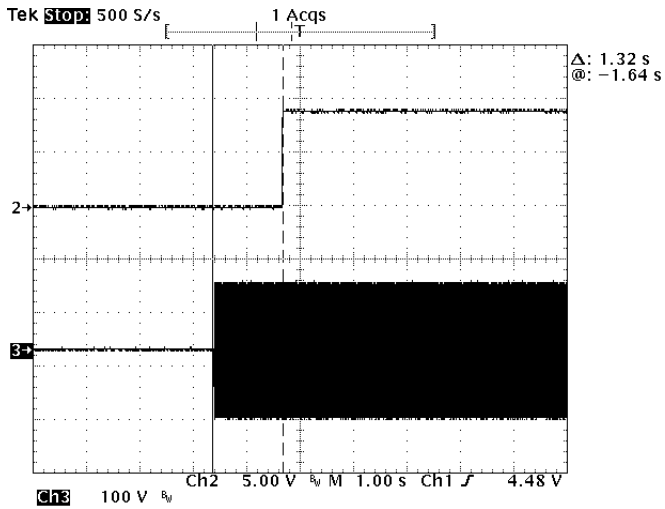

90V_{AC}, Full Load
 $T_{ST_DELAY} = 1.32S$

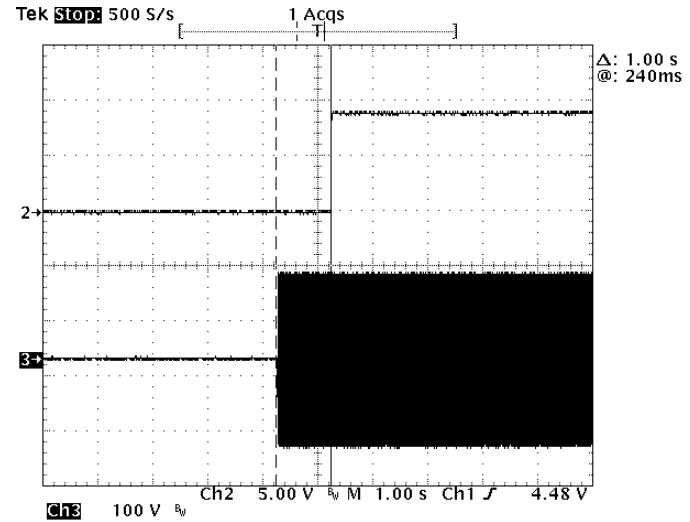

115V_{AC}, Full Load
 $T_{ST_DELAY} = 1.0S$

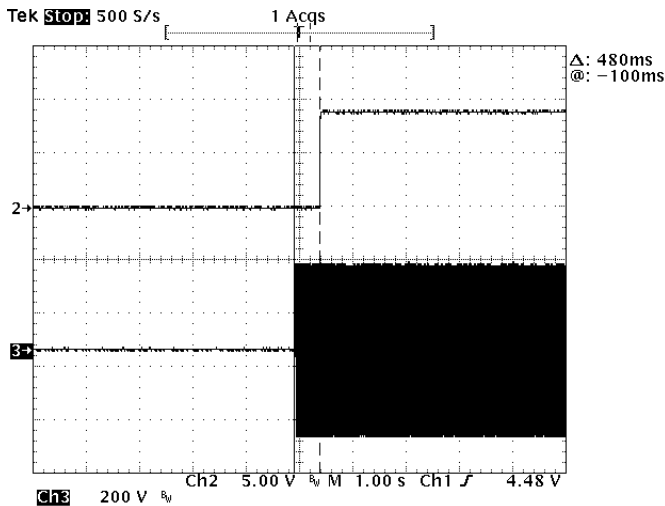

230V_{AC}, Full Load
 $T_{ST_DELAY} = 0.48S$

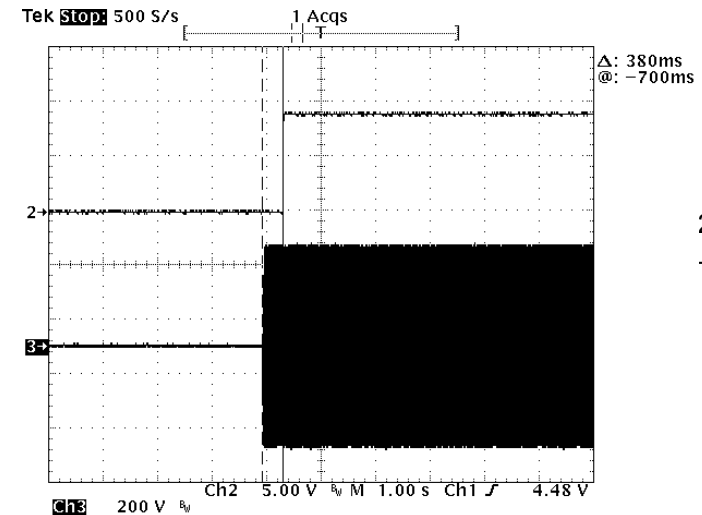

264V_{AC}, Full Load
 $T_{ST_DELAY} = 0.38S$

11. AC Startup Voltage Characteristic



No Load, $V_{IN_STARTUP} = 64V_{AC}$

Full Load, $V_{IN_STARTUP} = 74.4V_{AC}$

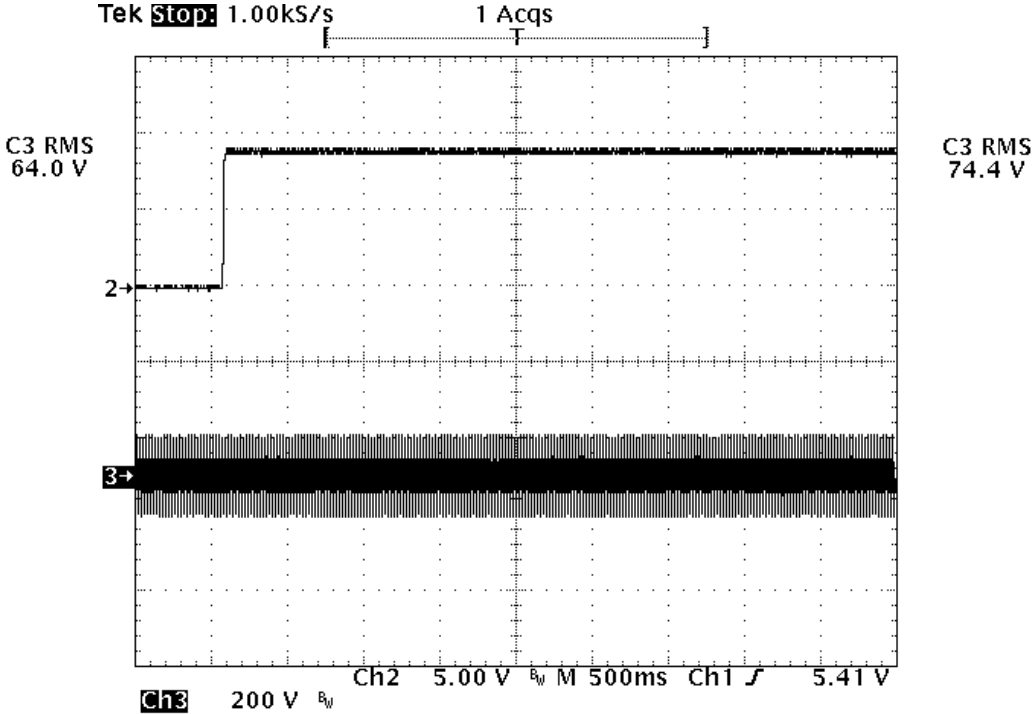
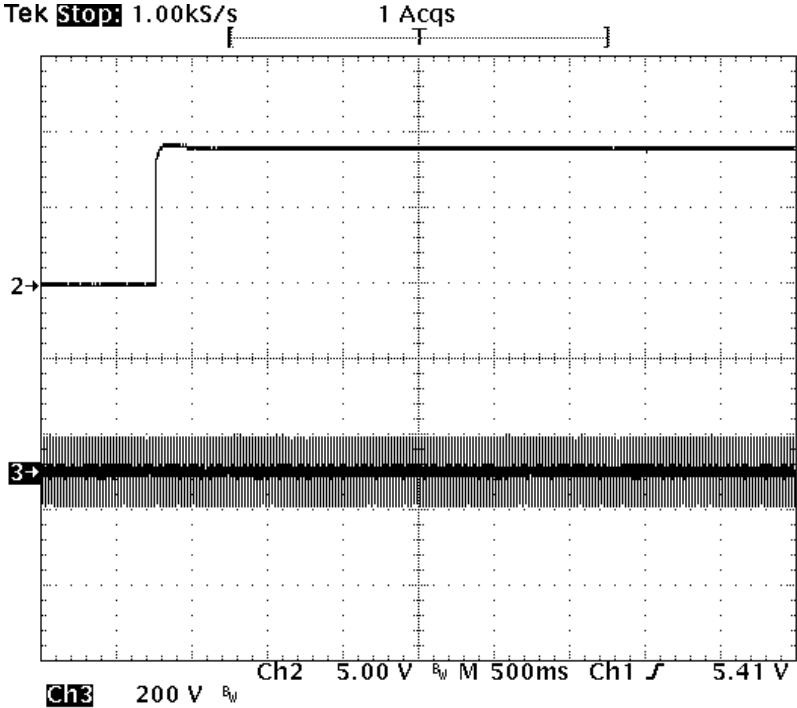

12. AC Brownout Voltage Characteristic

No Load, $V_{IN_STARTUP} = 37.6V_{AC}$

Full Load, $V_{IN_STARTUP} = 74.0V_{AC}$

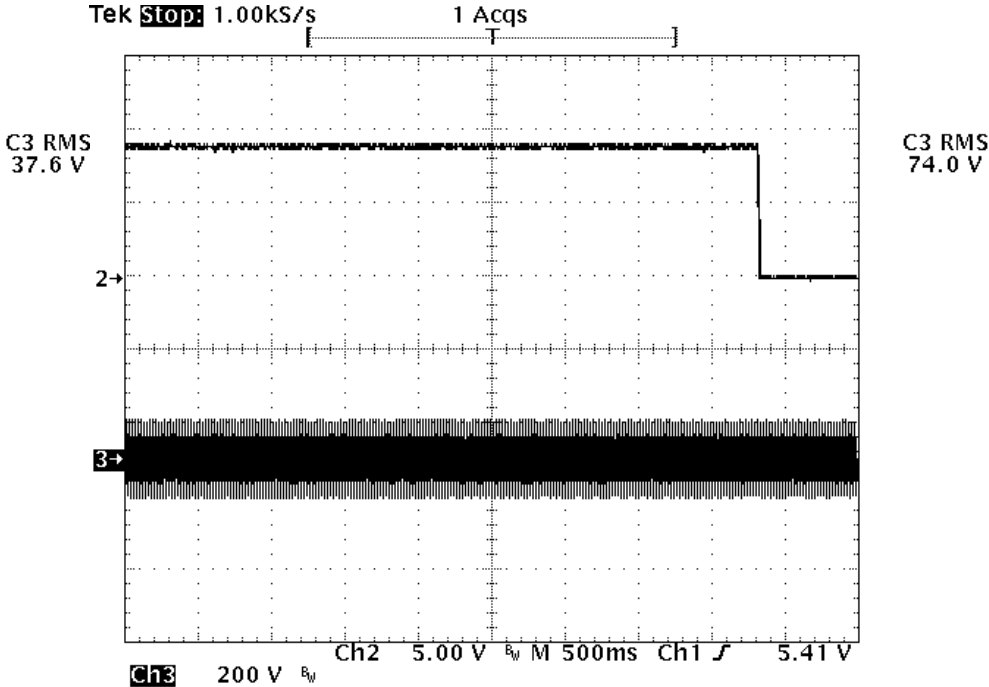
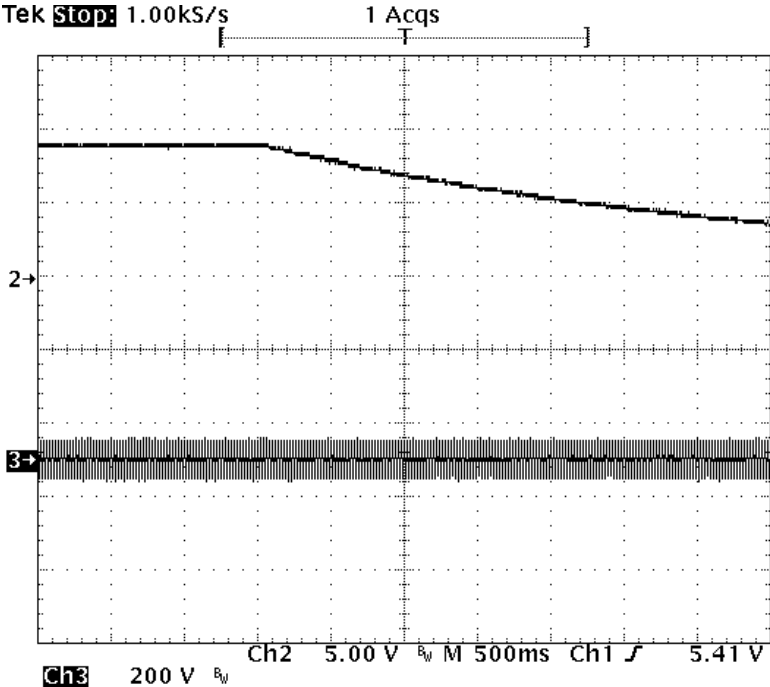

13.1 Dynamic Load Response

Condition: 1). Load: 0A-1.0A-0A 2).Slew-Rate: 0.15A/uS 3).Freq.: 100Hz 4). Duty-Cycle: 50%

* Note: Output voltage is monitored at end of PCB

Vin=90VAC

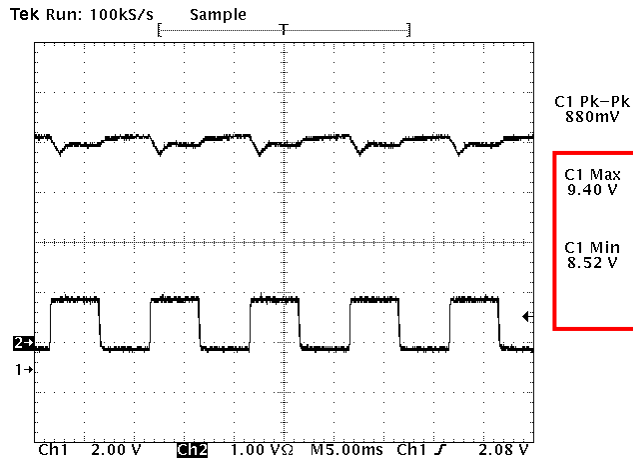

Vin=115VAC

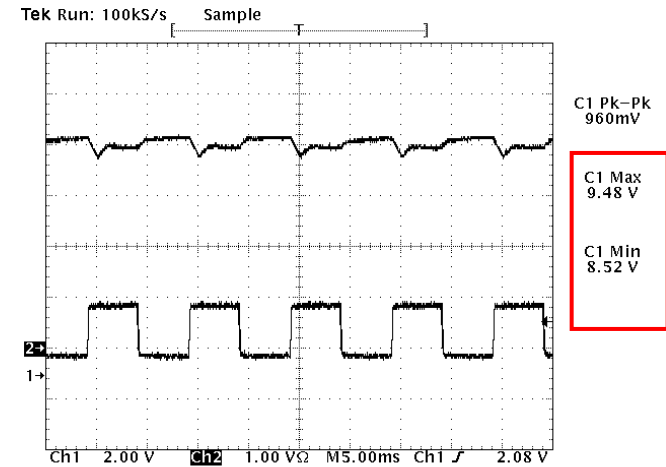

Vin=230VAC

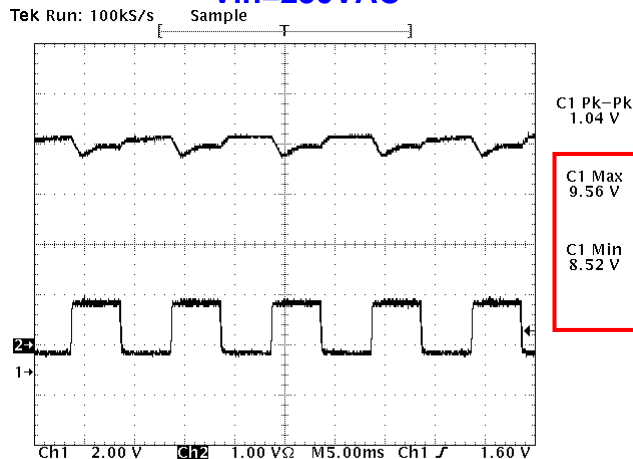

Vin=264VAC

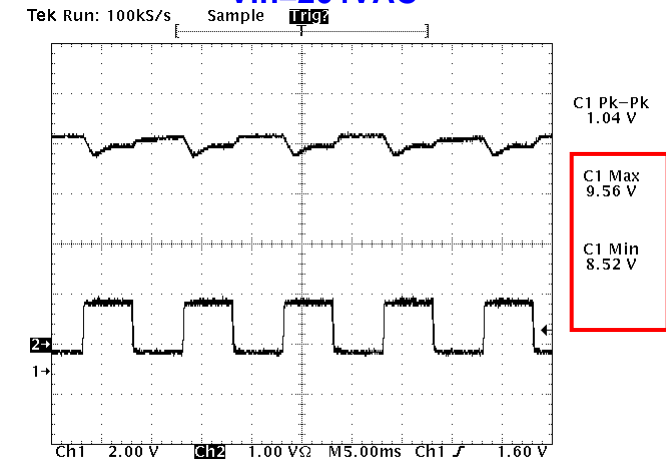

13.2 Dynamic Load Response

Condition: 1). Load: 1.0A-2.0A-1.0A 2).Slew-Rate: 0.15A/uS 3).Freq.: 100Hz 4). Duty-Cycle: 50%



* Note: Output voltage is monitored at end of PCB

Vin=90VAC

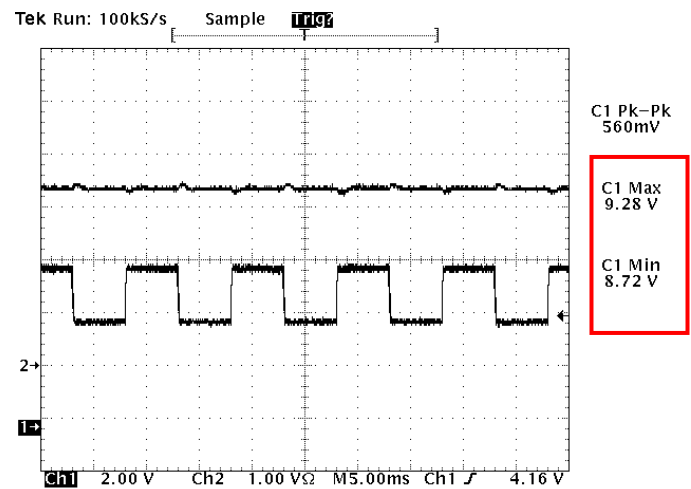

Vin=115VAC

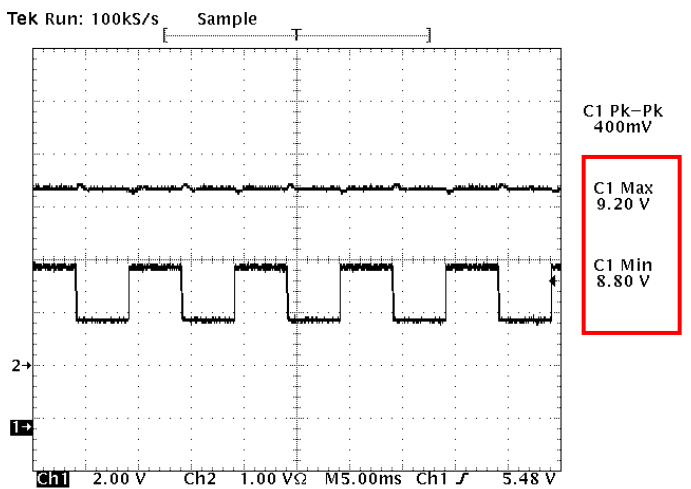

Vin=230VAC

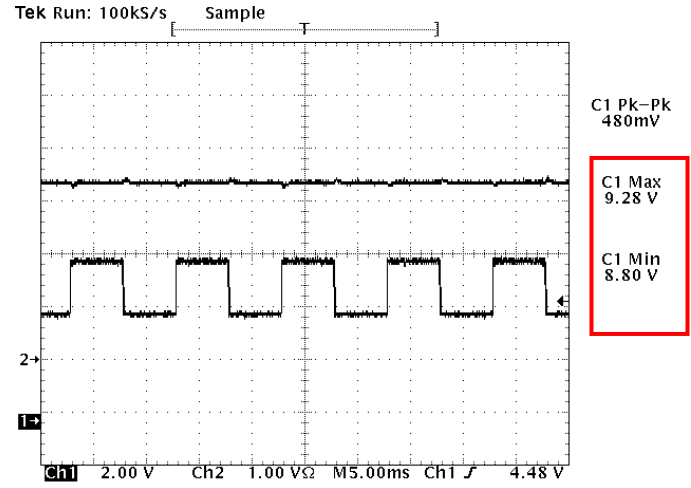

Vin=264VAC

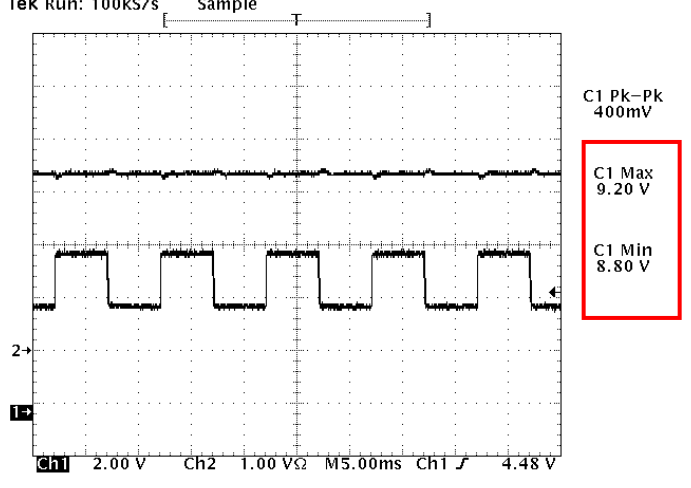

14. V_{DS} Waveform

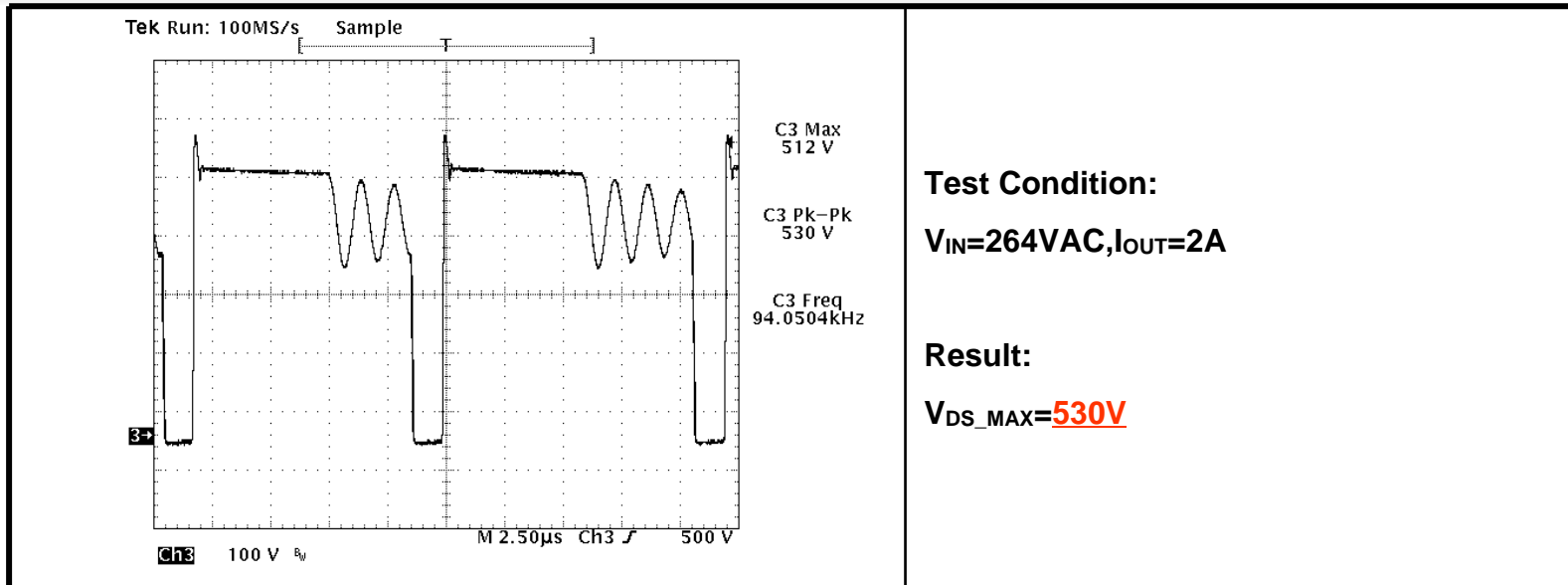

Appendix – Simple Specification for used Transistor (STB4NK60Z)

Symbol	Parameter	Value		Unit
		TO-220 - D ² PAK DPAK-IPAK-I ² PAK	TO-220FP	
V_{DS}	Drain-source voltage ($V_{GS} = 0$)	600		V
V_{GS}	Gate- source voltage	± 30		V
I_D	Drain current (continuous) at $T_C = 25\text{ }^\circ\text{C}$	4	4 (1)	A
I_D	Drain current (continuous) at $T_C = 100\text{ }^\circ\text{C}$	2.5	2.5 (1)	A
$I_{DM}^{(2)}$	Drain current (pulsed)	16	16 (1)	A
P_{TOT}	Total dissipation at $T_C = 25\text{ }^\circ\text{C}$	70	25	W
	Derating factor	0.56	0.2	W/ $^\circ\text{C}$
$V_{ESD(G-S)}$	Gate source ESD(HBM-C=100 pF, R=1.5 k Ω)	3000		V
$dv/dt^{(3)}$	Peak diode recovery voltage slope	4.5		V/ns
V_{ISO}	Insulation withstand voltage (RMS) from all three leads to external heat sink ($t=1\text{ s}; T_C = 25\text{ }^\circ\text{C}$)	-	2500	V
T_{stg}	Storage temperature	-55 to 150		$^\circ\text{C}$
T_j	Max operating junction temperature	150		$^\circ\text{C}$

15. Conducted EMI

$V_{IN}=230Vac$, Live

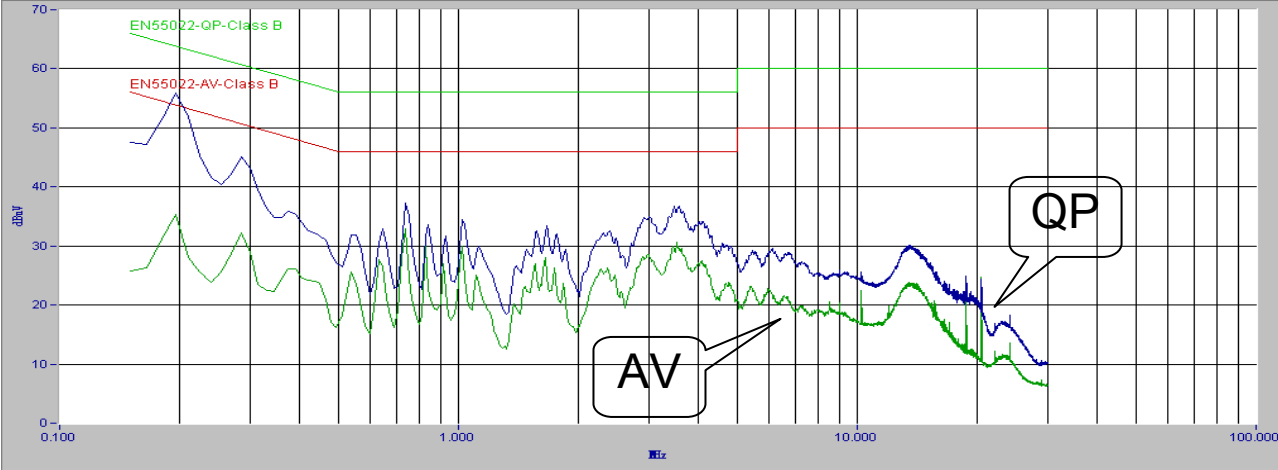

$V_{IN}=230Vac$, Neutral

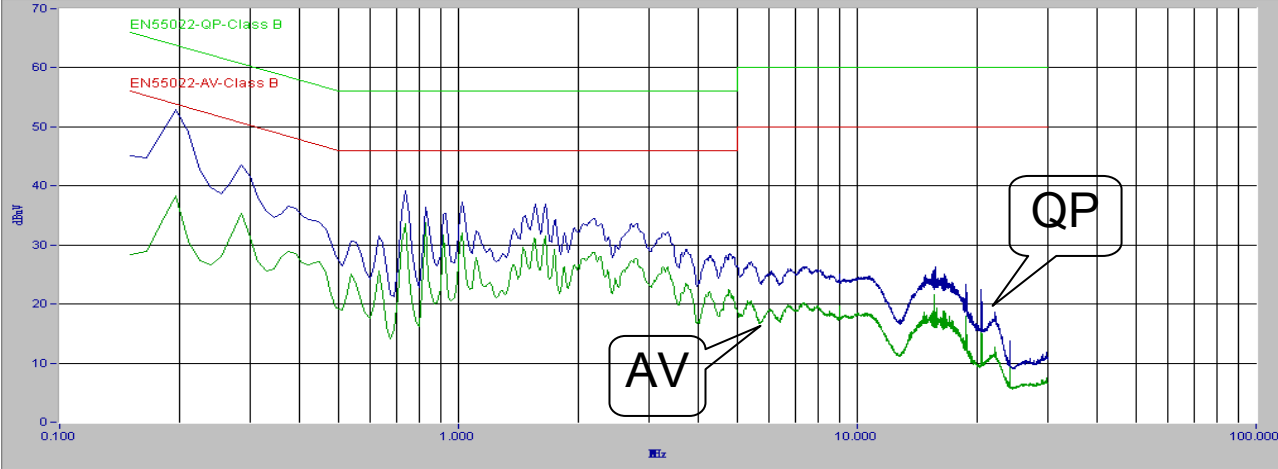

Note: Full & Resistive Load and output is Grounded