

DESCRIPTION:

PT4204 is targeted to sub-5W LED lighting applications. It is designed for the flyback topology, and regulates output current without the secondary feedback loop. A 600V power switch is integrated into PT4204 which is helpful for reducing the circuit board dimension and system total cost.

Accurate CC (constant current) regulation can be achieved with built in compensation circuitry. Integrated line and primary inductance compensation ensures output current free of line voltage and primary inductance variations.

Complete protection functions have been integrated allows PT4204 to protect against all fault conditions including cycle by cycle current limit, output open/short circuit, line under-voltage, and over temperature shut down.

PT4204 is available in SOP-8 package.

FEATURES

- CC Control Without Secondary Feed back
- Compensates transformer Inductor Variation
- Built in 600V power switch
- Output Over Voltage Protection
- Output Short Circuit Protection
- Feedback resistor open circuit protection
- Line Under Voltage Protection
- Cycle by Cycle Current Limit
- Over Temperature Protection

APPLICATIONS

- 1~5W LED Power Supplier

ORDERING INFORMATION

PACKAGE	TEMPERATURE RANGE	ORDERING PART NUMBER	TRANSPORT MEDIA	MARKING
SOP8	-40°C to 85°C	PT4204ESOH	Tape and Reel	PT4204 xxxxxX

Note:



TYPICAL APPLICATION CIRCUIT

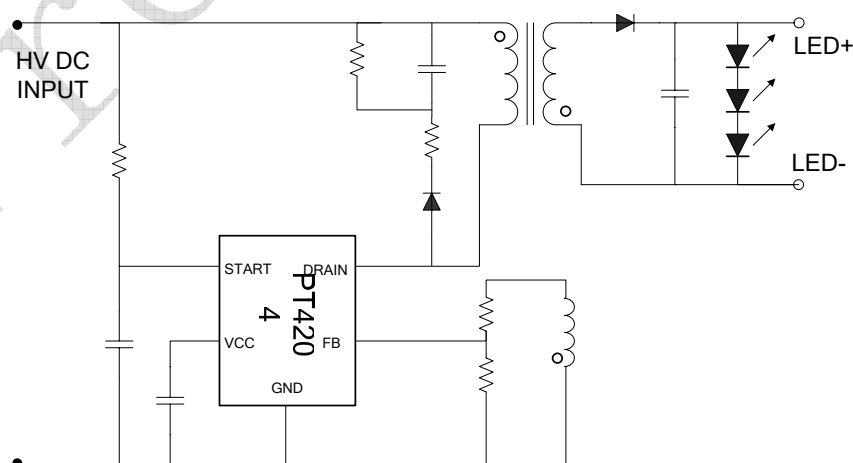

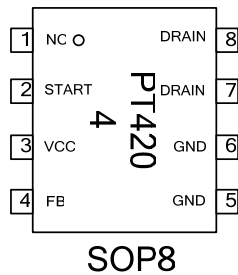
PIN ASSIGNMENT

PIN DESCRIPTIONS

NO.	PIN NAME	DESCRIPTION
1	NC	No connection
2	START	Start up control pin, must be locally bypassed
3	VCC	DC power supply pin, must be locally bypassed
4	FB	Feedback Winding Voltage Sense Input
5,6	GND	Ground
7,8	DRAIN	Internal 600V switch drain

ABSOLUTE MAXIMUM RATINGS (note 1, 2, 3)

SYMBOL	PARAMETER	VALUE	UNIT
V _{CC}	VCC Supply Voltage	-0.3~6	V
START	START input voltage	-0.3~15	V
FB	FB input range	-0.3~6	V
DRAIN	DRAIN maximum reverse voltage	-0.3~600	V
P _{DMAX}	Power dissipation (note2)	0.43	W
P _{TR1}	Heat resistance R _{θJA}	150	°C/W
T _J	Junction temperature	-40 to 150	°C
T _{STG}	Storage temperature	-55 to 150	°C
HBM	ESD sensitivity level(note3)	2	kV

RECOMMENDED OPERATING RANGE

SYMBOL	PARAMETER	VALUE	UNIT
V _{CC}	Power supply voltage	5.5	V
T _{OPT}	Operating ambient temperature	-20 to +85	°C

Note 1: Absolute Maximum Ratings indicate limits beyond which damage to the device may occur. Recommended Operating Range indicates conditions for which the device is functional, but do not guarantee specific performance limits. Electrical Characteristics state DC and AC electrical specifications under particular test conditions which guarantee specific performance limits. This assumes that the device is within the Operating Range. Specifications are not guaranteed for parameters where no limit is given, however, the typical value is a good indication of device performance.

Note 2: The maximum power dissipation must be derated at elevated temperatures and is dictated by T_{JMAX}, θ_{JA}, and the ambient temperature T_A. The maximum allowable power dissipation is P_{DMAX} = (T_{JMAX} - T_A) / θ_{JA} or the number given in Absolute Maximum Ratings, whichever is lower.

Note 3: Human body model, 100pF discharged through a 1.5kΩ resistor.

ELECTRICAL CHARACTERISTICS

 (T_{OPT}=25°C, V_{CC}=5.5V, unless specified otherwise)

SYMBOL	PARAMETER	TEST CONDITION	MIN	TYP	MAX	UNIT
VCC Supply and Start up (VCC andSTART)						
V _{START_ON}	START on threshold	START rising	9	11	13	V
V _{START_OFF}	START off threshold	START falling	5.5	7.5	9.5	V
V _{START_CLMP}	START clamp voltage	I(V _{START})=5mA	11.5	13	14.5	V
V _{CC}	VCC operating voltage			6		V
V _{CC_CLMP}	VCC clamp voltage	I(V _{CC})=5mA		6.5		V
V _{CC_UVLO}	VCC UVLO threshold	VCC falling	4.0	4.5	5	V
I _{CH}	VCC charge current	V _{CC} =0V, V _{DRAIN} =20V	-7.5	-5	-2.5	mA
Feedback (FB)						
V _{FBMAX}	FB over voltage threshold		2.25	2.5	2.75	V
V _{FBMIN}	FB minimum voltage			0.50		V
I _{FB_OPEN}	FB open loop protection threshold			-120		uA
OSCILLATOR						
F _{osc}	Oscillator frequency	FB=2.25V, I _{FB} ×Ton=1.5mA*uS note(4)	60	65	70	kHz
D _{MAX}	Maximum duty cycle			60		%
Driver output (DRAIN)						
R _{DS(ON)}	On state resistance	V _{START} =12V I _{DRAIN} =410mA		8	15	Ω
I _{DS}	Off state leak current	V _{START} =0, V _{DS} =600V			25	uA
BV _{DS}	DRAIN breakdown voltage	V _{START} =0, I _{DRAIN} =250uA	600			V
T _{LEB}	Current sense leading edge blanking time			300		ns
Protection						
I _{LIMIT}	SW peak current	di/dt=100 mA/us	381	410	438	mA
T _{SD}	Over temperature shut down threshold			150		°C
T _{SDHYS}	Over temperature shut down hysteresis			50		°C
T _{AR_ON}	Fault condition restart time			4		S

Note 4: including ± 7% jittering

SIMPLIFIED BLOCK DIAGRAM

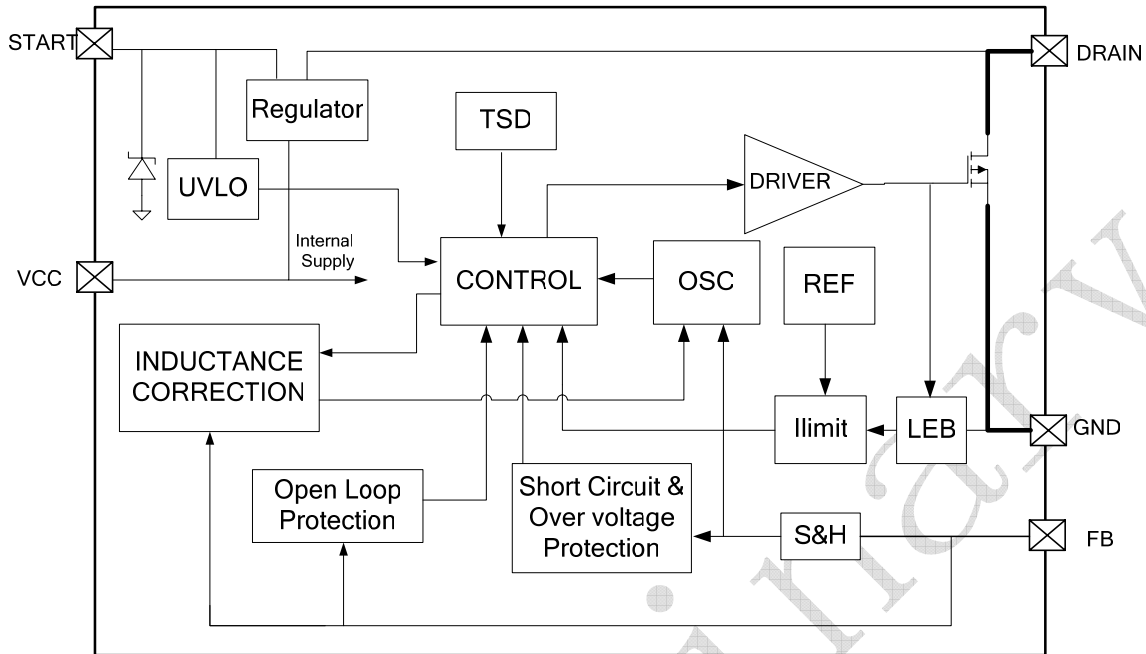

PACKAGE INFORMATION

SOP8

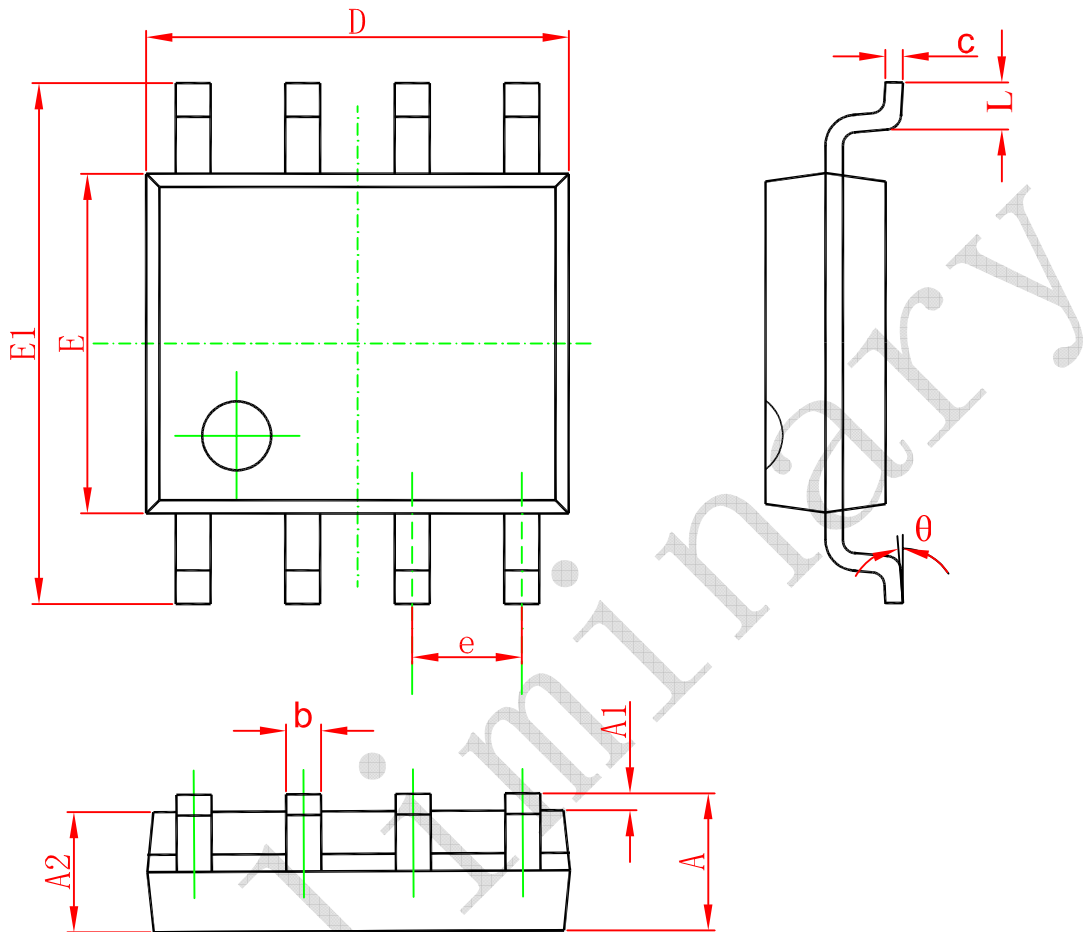

SYMBOL	DIMENSIONS IN MILLIMETERS		DIMENSIONS IN INCH	
	MIN	MAX	MIN	MAX
A	1.350	1.750	0.053	0.069
A1	0.100	0.250	0.004	0.010
A2	1.350	1.550	0.053	0.061
b	0.330	0.510	0.013	0.020
c	0.170	0.250	0.006	0.010
D	4.700	5.100	0.185	0.200
E	3.800	4.000	0.150	0.157
E1	5.800	6.200	0.228	0.244
e	1.270(BSC)		0.050(BSC)	
L	0.400	1.270	0.016	0.050
θ	0°	8°	0°	8°