

Features

- Switch mode controller for single switch LED drivers
- Open loop peak current controller
- Constant frequency or constant off-time operation
- Linear and PWM dimming capability
- Requires few external components for operation
- Application from a few mA to more than 1A output

Applications

- DC/DC or AC/DC LED driver applications
- RGB backlighting LED driver
- Back lighting of flat panel displays
- General purpose constant current source
- Signage and decorative LED lighting

Description

The PAM99700 is an open loop current mode control LED driver IC. The PAM99700 can be programmed to operate in either a constant frequency or constant off-time mode. It includes an 12 – 500V regulator which allows it to work from a wide range of input voltages without the need for an external low voltage supply. The PAM99700 includes a PWM dimming input that can accept an external control signal with a duty ratio of 0 – 100% and a frequency of up to a few kilohertz. It also includes a 0 – 250mV linear dimming input which can be used for linear dimming of the LED current.

The PAM99700 is ideally suited for buck LED drivers. Since the PAM99700 operates in open loop current mode control, the controller achieves good output current regulation without the need for any loop compensation. PWM dimming response is limited only by the rate of rise and fall of the inductor current, enabling very fast rise and fall times. The PAM99700 requires only three external components (apart from the power stage) to produce a controlled LED current making it an ideal solution for low cost LED drivers.

Typical Application

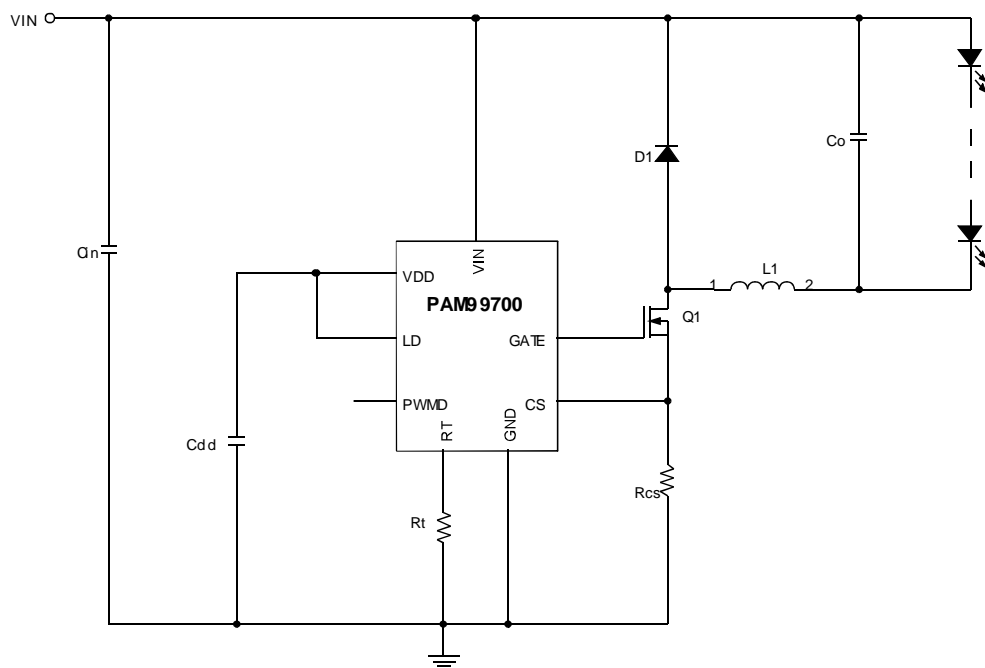

Block Diagram

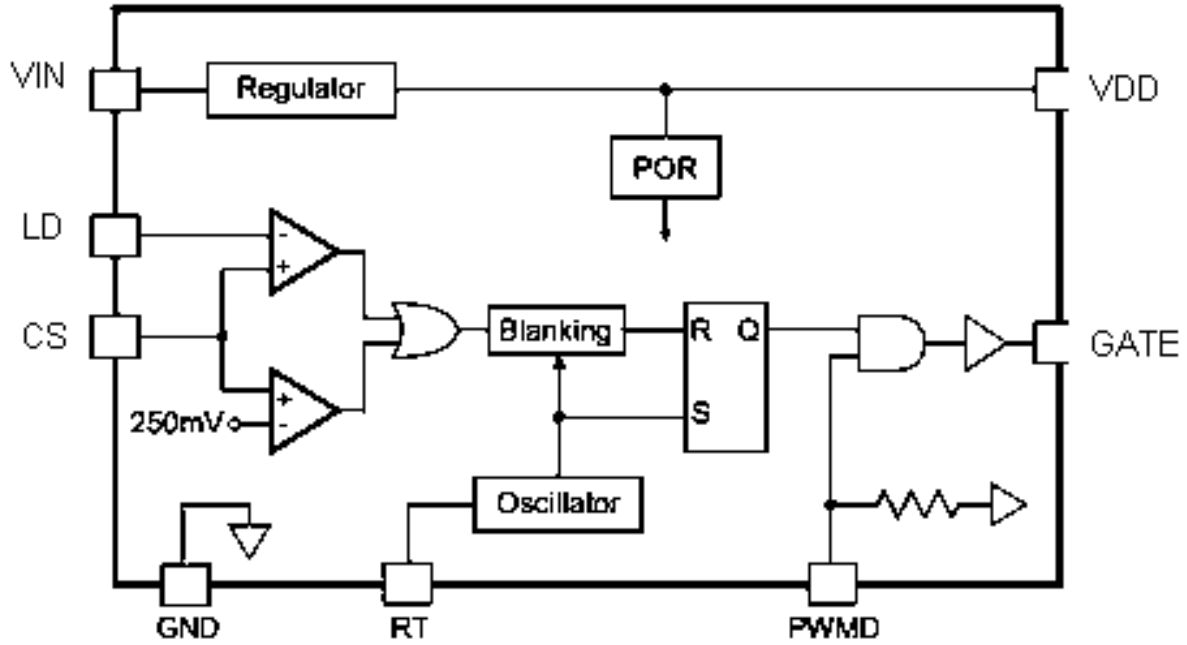

Pin Configuration & Marking Information

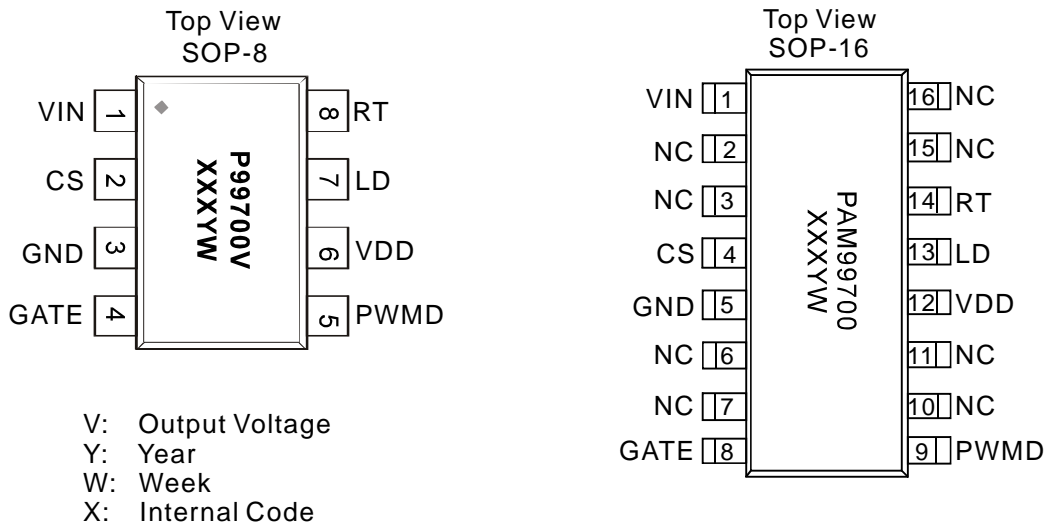

Pin Description

| Name | SOP8 | SOP16 | Function |
|------|------|------------------------|---|
| VIN | 1 | 1 | This pin is the input of an 12V-500V regulator |
| CS | 2 | 4 | This pin is the current sense pin used to sense the FET current by means of an external sense resistor. When this pin exceeds the lower of either the internal 250mV or the voltage at the LD pin, the gate output goes low. |
| GND | 3 | 5 | Ground return for all internal circuitry. This pin must be electrically connected to the ground of the power train. |
| GATE | 4 | 8 | This pin is the output gate driver for an external N-channel power MOSFET. |
| PWMD | 5 | 9 | This is the PWM dimming input of the IC. When this pin is pulled to GND, the gate driver is turned off. When the pin is pulled high, the gate driver operates normally. |
| VDD | 6 | 12 | This is the power supply pin for all internal circuits. It must be bypassed with a low ESR capacitor to GND (~ 10µF). |
| LD | 7 | 13 | This pin is the linear dimming input and sets the current sense threshold as long as the voltage at the pin is less than 250mV (typ). |
| RT | 8 | 14 | This pin sets the oscillator frequency. When a resistor is connected between RT and GND, the PAM99700 operates in constant frequency mode. When the resistor is connected between RT and GATE, the IC operates in constant off-time mode. |
| NC | | 2,3,6,7,10 11,15,16 | No connected |



Absolute Maximum Ratings

These are stress ratings only and functional operation is not implied. Exposure to absolute maximum ratings for prolonged time periods may affect device reliability. All voltages are with respect to ground.

Maximum Junction Temperature.....150°C
 Storage Temperature Range.....-65°C to 150°C
 Soldering Temperature.....300°C, 5sec

Recommended Operating Conditions

Supply Voltage.....12V to 500V Junction Temperature Range.....-40°C to 125°C
 Ambient Temperature Range.....-40°C to 85°C

Thermal Information

| Parameter | Symbol | Package | Maximum | Unit |
|--|---------------|---------|---------|------|
| Thermal Resistance (Junction to Ambient) | θ_{JA} | SOP-8 | 115 | °C/W |
| | | SOP-16 | 110 | |

Electrical Characteristic

$T_A=25^\circ\text{C}$, unless otherwise noted.

| PARAMETER | SYMBOL | Test Conditions | MIN | TYP | MAX | UNITS |
|---|---------|-------------------|-----|-----|-----|-------|
| Input Voltage Range | VINDC | DC input voltage | 12 | | 500 | V |
| Shutdown mode supply current | IINSD | Pin PWMD to GND | | 0.1 | | mA |
| Internally regulated voltage | VDD | Vin>20V | 6 | 10 | | V |
| Current sense pull-in threshold voltage | VCS,TH | | | 250 | | mV |
| Current sense blanking interval | TBLANK | | | 250 | | ns |
| Gate sourcing current | ISOURCE | VGATE=0V | 0.2 | | | A |
| Gate sinking current | ISINK | VGATE=VDD | 0.2 | | | A |
| Gate output rise time | tRISE | CGATE=1nF | | 30 | 50 | ns |
| Gate output fall time | tTALL | CGATE=1nF | | 30 | 50 | ns |
| Oscillator frequency | fOSC | RT= 510k Ω | 37 | 41 | 49 | kHz |
| | | RT= 226k Ω | 74 | 92 | 110 | |
| EN Threshold High | VEH | Vin=12V~500V | 2.4 | | | V |
| EN Threshold Low | VEL | Vin=12V~500V | | | 1.0 | V |
| Over Temperature Protection | OTP | | | 160 | | °C |
| OTP Hysteresis | OTH | | | 50 | | °C |

Typical Performance Characteristics

$T_A=25^\circ\text{C}$, $V_{in}=60\text{V}$, 1WLED , $R_T=510\text{Kohm}$, $L=5.2\text{mH}$, unless otherwise noted.

1. Input Voltage vs Shutdown Current

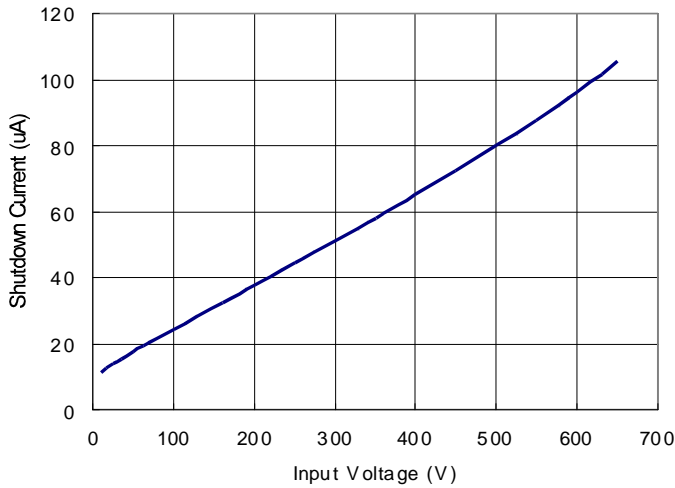

2. Input Voltage vs Supply Current

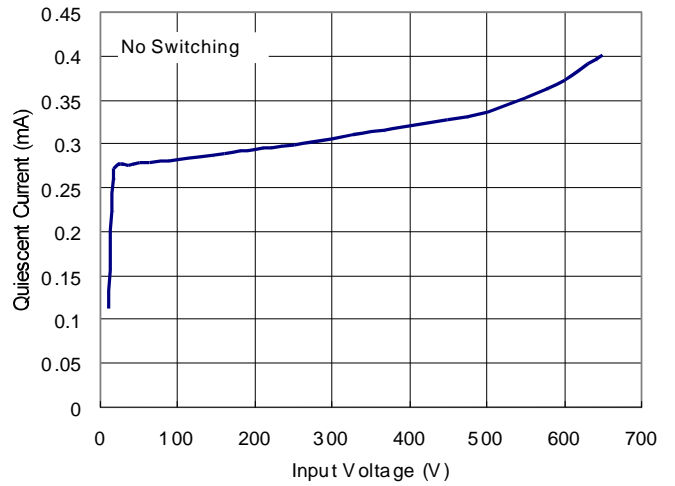

3. Input Voltage vs Quiescent Current

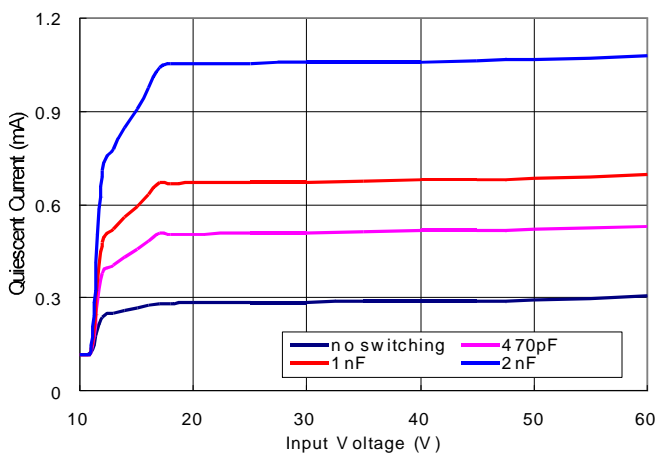

4. LD Voltage vs Output LED Current

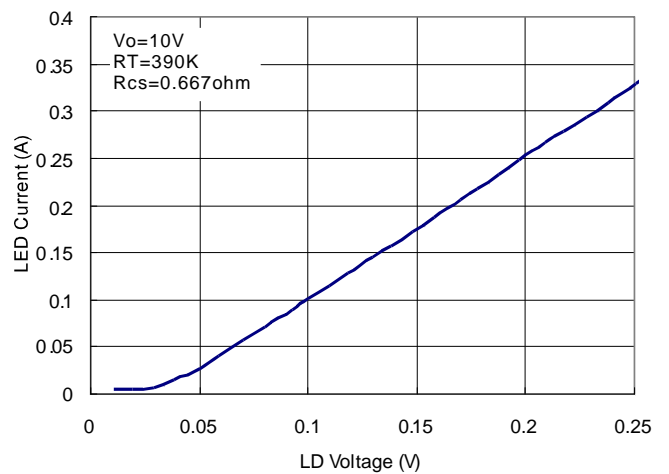

5. RT Resistor vs Switching Frequency

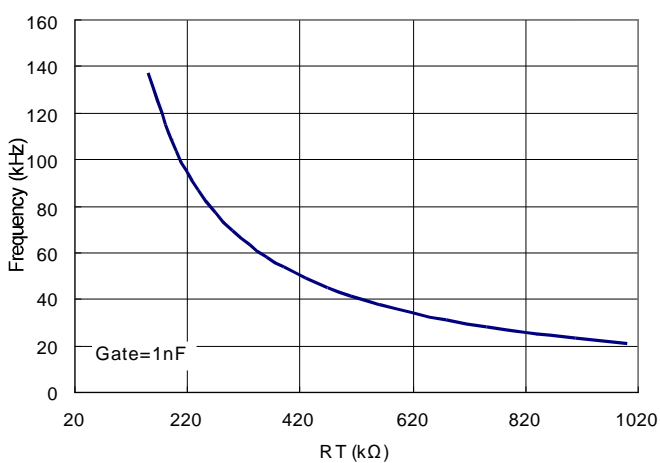

6. RT vs Constant Toff Time

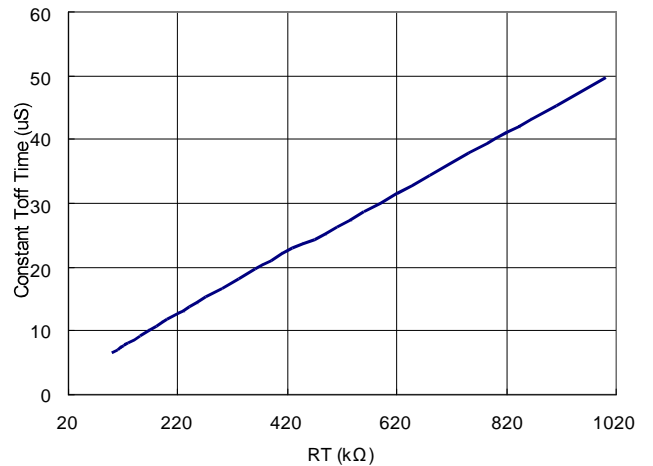

Typical Performance Characteristics

$T_A=25^{\circ}\text{C}$, $V_{in}=110\text{Vac}$, 1WLED , $R_T=510\text{Kohm}$, $L=5.2\text{mH}$, $R_{cs}=0.68\text{ohm}$, unless otherwise noted.

7. Input Voltage vs Efficiency

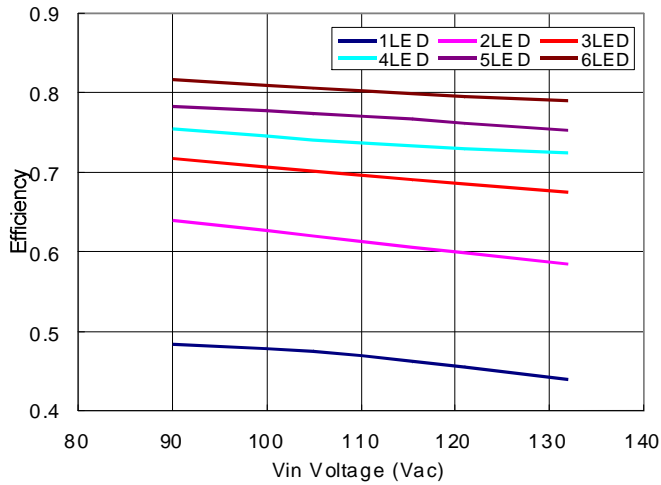

8. Input Voltage vs LED Current

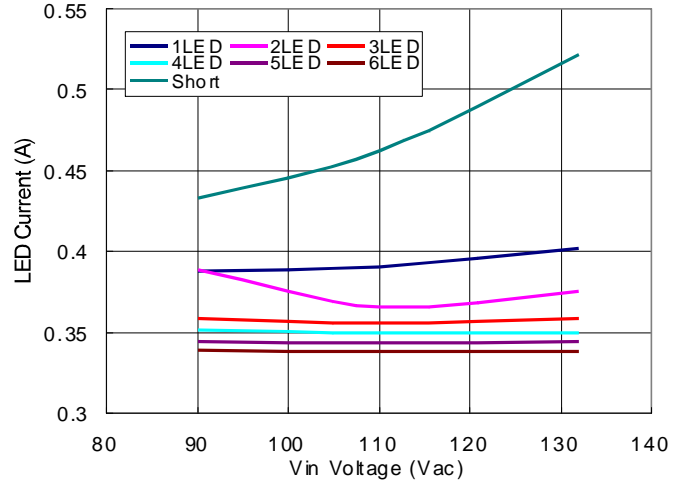

9. Output Voltage vs Efficiency

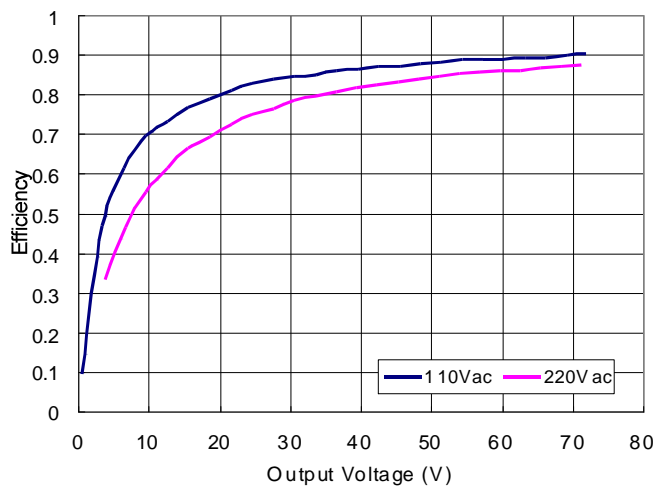

10. Output Voltage vs LED Current

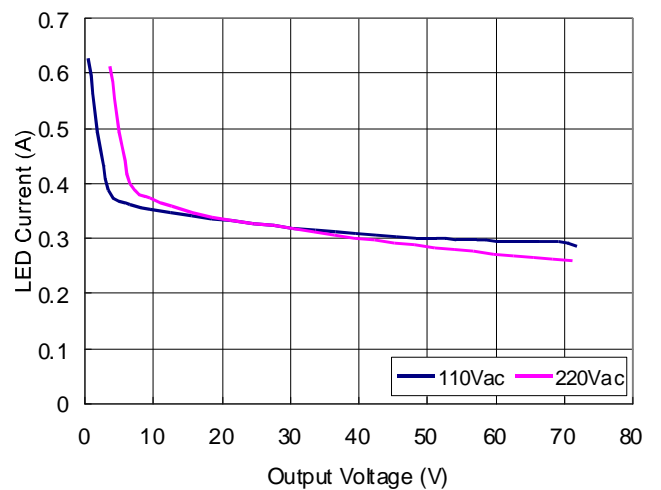

11. PWM Dimming use PWM_D pin

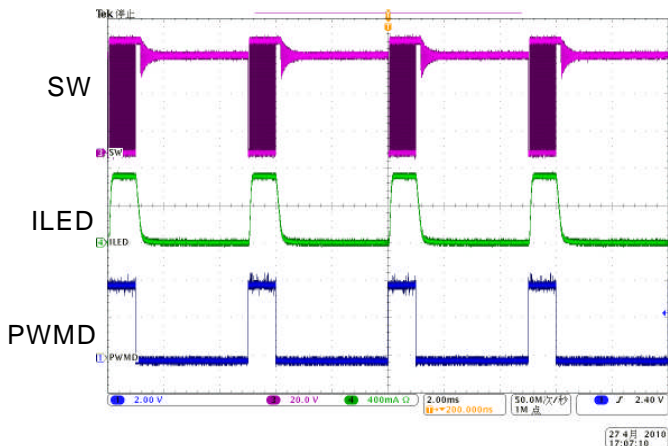

12. PWM Dimming use PWM_D pin

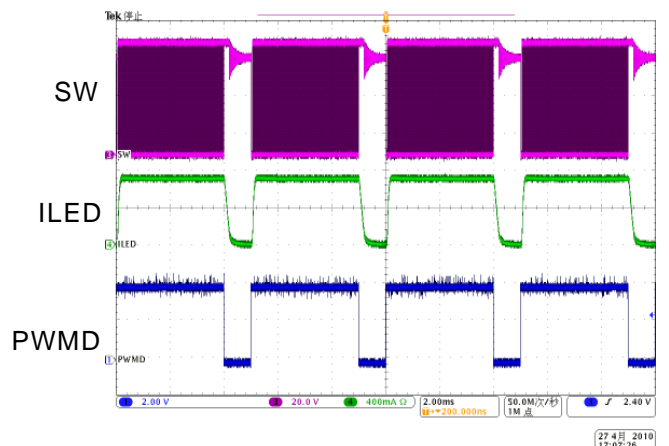



Application Information

The PAM99700 is optimized to drive buck LED drivers using open-loop peak current mode control. This method of control enables fairly accurate LED current control without the need for high side current sensing or the design of any closed loop controllers. The IC uses very few external components and enables both Linear and PWM dimming of the LED current.

A resistor connected to the RT pin programs the frequency of operation (or the off-time). The oscillator produces pulses at regular intervals. These pulses set the SR flip-flop in the PAM99700 which causes the gate driver to turn on. The same pulses also start the blanking timer which inhibits the reset input of the SR flip flop and prevent false turn-offs due to the turn-on spike. When the FET turns on, the current through the inductor starts ramping up. This current flows through the external sense resistor R_{cs} and produces a ramp voltage at the CS pin. The comparators are constantly comparing the CS pin voltage to both the voltage at the LD pin and the internal 250mV. Once the blanking timer is complete, the output of these comparators is allowed to reset the flip flop. When the output of either one of the two comparators goes high, the flip flop is reset and the gate output goes low. The gate goes low until the SR flip flop is set by the oscillator. Assuming a 30% ripple in the inductor, the current sense resistor R_{cs} can be set using:

$$R_{cs} = 0.25V \text{ (or } V_{LD}) / 1.15 * I_{LED}(A)$$

Constant frequency peak current mode control has an inherent disadvantage – at duty cycles greater than 0.5, the control scheme goes into subharmonic oscillations. To pre-vent this, an artificial slope is typically added to the current sense waveform. This slope compensation scheme will affect the accuracy of the LED current in the present form. However, a constant off-time peak current control scheme does not have this problem and can easily operate at duty cycles greater than 0.5 and also gives inherent input volt-age rejection making the LED current almost insensitive to input voltage variations. But, it leads to variable frequency operation and the frequency range depends greatly on the input and output voltage variation. PAM99700 makes it easy to switch between the two modes of operation by changing one connection (see oscillator section).

Input Voltage Regulator

The PAM99700 can be powered directly from its VIN pin and can work from 12-500V DC at its VIN pin. When a voltage is applied at the VIN pin, the PAM99700 maintains a constant 12V at the VDD pin. This voltage is used to power the IC and any external resistor dividers needed to control the IC. The VDD pin must be bypassed by a low ESR capacitor to provide a low impedance path for the high frequency current of the output gate driver.

The PAM99700 can also be operated by supplying a voltage at the VDD pin greater than the internally regulated voltage. This will turn off the internal linear regulator of the IC and the PAM99700 will operate directly off the voltage supplied at the VDD pin. Please note that this external voltage at the VDD pin should not exceed 15V.

Although the VIN pin of the PAM99700 is rated up to 500V, the actual maximum voltage that can be applied is limited by the power dissipation in the IC. For example, if an 8-pin(junction to ambient thermal resistance $R_{\theta j-a} = 115^{\circ}C/W$) PAM99700 draws about $I_{in} = 2mA$ from the VIN pin, and has a maximum allowable temperature rise of the junction temperature limited to about $\Delta T = 100^{\circ}C$, the maximum volt-age at the VIN pin would be:

$$\begin{aligned} V_{IN(MAX)} &= \frac{\Delta T}{R_{\theta j-a}} \cdot \frac{1}{I_{in}} \\ &= \frac{100^{\circ}C}{115^{\circ}C/W} \cdot \frac{1}{2mA} \\ &= 435V \end{aligned}$$

In these cases, to operate the PAM99700 from higher input voltages, a Zener diode can be added in series with the VIN pin to divert some of the power loss from the PAM99700 to the Zener diode. In the above example, using a 100V zener diode will allow the circuit to easily work up to 500V.

The input current drawn from the VIN pin is a sum of the 1.0mA current drawn by the internal circuit and the current drawn by the gate driver (which in turn depends on the switching frequency and the gate charge of the external FET).

$$I_{IN} \approx 350\mu A + Q_G * f_s$$

In the above equation, f_s is the switching frequency and Q_g is the gate charge of the external FET (which can be obtained from the datasheet of the FET).

Current Sense

The current sense input of the PAM99700 goes to the non-inverting inputs of two comparators. The inverting terminal of one comparator is tied to an internal 250mV reference whereas the inverting terminal of the other comparator is connected to the LD pin. The outputs of both these comparators are fed into an OR gate and the output of the OR gate is fed into the reset pin of the flip-flop. Thus, the comparator which has the lowest voltage at the inverting terminal determines when the GATE output is turned off.

The outputs of the comparators also include a 150-280ns blanking time which prevents spurious turn-offs of the external FET due to the turn-on spike normally present in peak current mode control. In rare cases, this internal blanking might not be enough to filter out the turn-on spike. In these cases, an external RC filter needs to be added between the external sense resistor (R_{CS}) and the CS pin.

Please note that the comparators are fast (with a typical 80ns response time). Hence these comparators are more susceptible to be triggered by noise than the comparators of the PAM99700. A proper layout minimizing external inductances will prevent false triggering of these comparators.

Oscillator

The oscillator in the PAM99700 is controlled by a single resistor connected at the RT pin. The equation governing the oscillator frequency is given by:

$$F = \frac{21380}{RT(k\Omega) + 5.5} \quad (\text{kHz})$$

If the resistor is connected between RT and GND, PAM99700 operates in a constant frequency mode and the above equation determines the time-period. If the resistor is connected between RT and GATE, the PAM99700 operates in a constant off-time mode and the below equation determines the off-time.

$$T_{off} = \frac{RT(k\Omega) + 44.1}{21.1} \quad (\mu\text{s})$$

GATE Output

The gate output of the PAM99700 is used to drive and external FET. It is recommended that the gate charge of the external FET be less than 25nC for switching frequencies 100kHz and less than 15nC for switching frequencies > 100kHz.

Linear Dimming

The Linear Dimming pin is used to control the LED current. There are two cases when it may be necessary to use the Linear Dimming pin.

In some cases, it may not be possible to find the exact R_{CS} value required to obtain the LED current when the internal 250mV is used. In these cases, an external voltage divider from the VDD pin can be connected to the LD pin to obtain a voltage (less than 250mV) corresponding to the desired voltage across R_{CS} .

Linear dimming may be desired to adjust the current level to reduce the intensity of the LEDs. In these cases, an external 0-250mV voltage can be connected to the LD pin to adjust the LED current during operation.

To use the internal 250mV, the LD pin can be connected to VDD.

Note: Although the LD pin can be pulled to GND, the output current will not go to zero. This is due to the presence of a minimum on-time (which is equal to the sum of the blanking time and the delay to output time) which is about 450ns. This will cause the FET to be on for a minimum of 450ns and thus the LED current when LD = GND will not be zero. This current is also dependent on the input voltage, inductance value, forward voltage of the LEDs and circuit parasitics. To get zero LED current, the PWMD pin has to be used.

PWM Dimming

PWM Dimming can be achieved by driving the PWMD pin with a low frequency square wave signal. When the PWM signal is zero, the gate driver is turned off and when the PWMD signal is high, the gate driver is enabled. Since the PWMD signal does not turn off the other parts of the IC, the response of the PAM99700 to the PWMD signal is almost instantaneous. The rate of rise and fall of the LED current is thus determined solely by the rise and fall times of the inductor current. To disable PWM dimming and enable the PAM99700 permanently, connect the PWMD pin to VDD.

Thermal Protection

When the die temperature exceeds 160°C, a reset occurs and the reset remains until the temperature decrease to 110°C, at which time the circuit can be restarted. When the die temperature exceeds 160°C, a reset occurs and the reset remains until the temperature decrease to 110°C, at which time the circuit can be restarted.



Ordering Information

PAM 99700 X X

Number of Pins

Package Type

| Package Type | Number of Pins |
|--------------|----------------|
| A: SOP-8 | C: 8 |
| B: SOP-16 | D: 16 |

Outline Dimensions

SOP-8

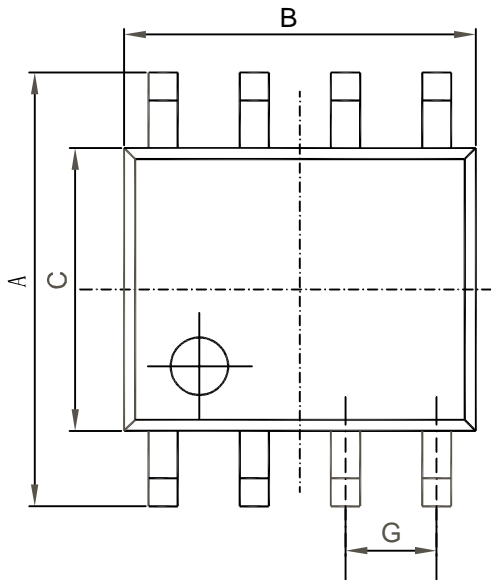

| REF | DIMENSIONS | |
|-----|-------------|------|
| | Millimeters | |
| | Min | Max |
| A | 5.80 | 6.20 |
| B | 4.80 | 5.00 |
| C | 3.80 | 4.00 |
| D | 0° | 8° |
| E | 0.40 | 0.90 |
| F | 0.19 | 0.25 |
| M | 0.10 | 0.25 |
| H | 0.35 | 0.49 |
| L | 1.35 | 1.75 |
| J | 0.375 REF | |
| K | 45° | |
| G | 1.27 TYP | |

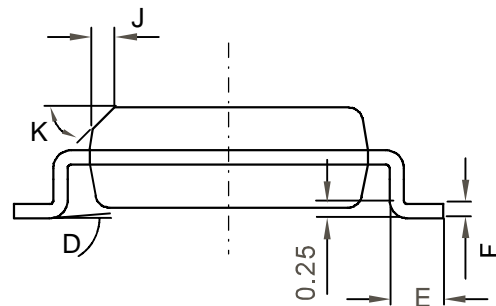
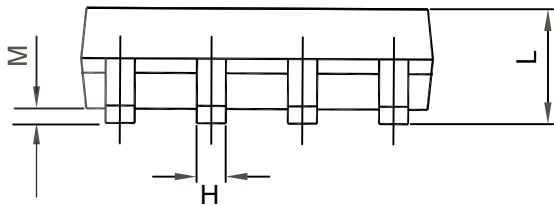

Outline Dimensions

SOP-16

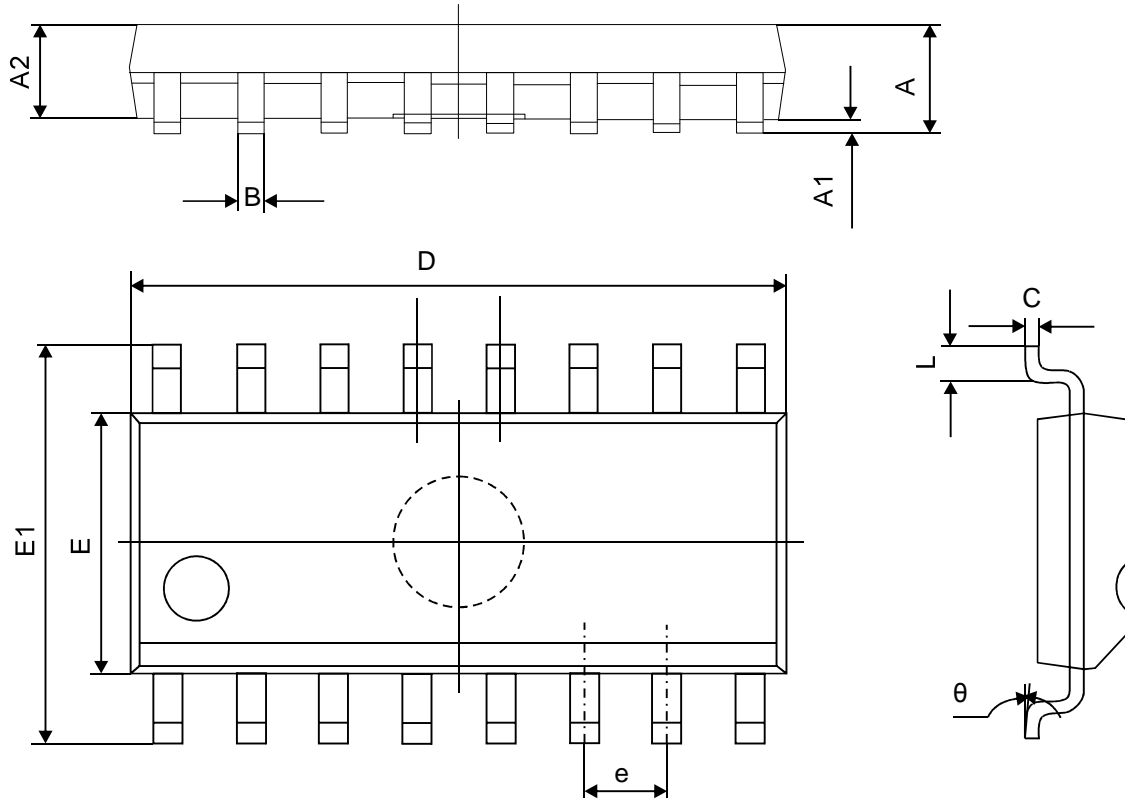

| Symbol | Dimensions Millimeters | |
|--------|------------------------|--------|
| | Min | Max |
| A | 1.350 | 1.750 |
| A1 | 0.100 | 0.250 |
| A2 | 1.350 | 1.550 |
| B | 0.330 | 0.510 |
| C | 0.190 | 0.250 |
| D | 9.800 | 10.000 |
| E | 3.800 | 4.000 |
| E1 | 5.800 | 6.300 |
| e | 1.270(TYP) | |
| L | 0.400 | 1.270 |
| θ | 0° | 8° |