

Go to: [1 - 100 Transistor Circuits](#)

**58 CIRCUITS as of 19-2-2010**

# Talking Electronics

See [TALKING ELECTRONICS WEBSITE](#)

email Colin Mitchell: [talking@tpg.com.au](mailto:talking@tpg.com.au)

## INTRODUCTION

This is the second half of our **Transistor Circuits** e-book. It contains a further 100 circuits, with many of them containing one or more Integrated Circuits (ICs).

It's amazing what you can do with transistors but when Integrated Circuits came along, the whole field of electronics exploded. IC's can handle both analogue as well as digital signals but before their arrival, nearly all circuits were analogue or very simple "digital" switching circuits.

Let's explain what we mean.

The word analogue is a waveform or signal that is changing (increasing and decreasing) at a constant or non constant rate.

Examples are voice, music, tones, sounds and frequencies. Equipment such as radios, TV's and amplifiers process analogue signals.

Then digital came along.

Digital is similar to a switch turning something on and off.

The advantage of digital is twofold.

Firstly it is a very reliable and accurate way to send a signal. The signal is either HIGH or LOW (On or OFF). It cannot be half-on or one quarter off.

And secondly, a circuit that is ON, consumes the least amount of energy in the controlling device. In other words, a transistor that is fully turned ON and driving a motor, dissipates the least amount of heat. If it is slightly turned ON or nearly fully turned ON, it gets very hot.

And obviously a transistor that is not turned on at all will consume no energy.

A transistor that turns ON fully and OFF fully is called a SWITCH.

When two transistors are cross-coupled in the form of a flip flop, any pulses entering the circuit cause it to flip and flop and the output goes HIGH on every second pulse. This means the circuit halves the input pulses and is the basis of counting or dividing.

Digital circuits also introduce the concept of two inputs creating a HIGH output when both are HIGH and variations of this.

This is called "logic" and introduces terms such as "Boolean algebra" and "gates."

Integrated Circuits started with a few transistors in each "chip" and increased to whole mini or micro computers in a single chip. These chips are called Microcontrollers and a single chip with a few surrounding components can be programmed to play games, monitor heart-rate and do all sorts of amazing things. Because they can process information at high speed, the end result can appear to have intelligence and this is where we are heading: AI (Artificial Intelligence).

But let's crawl before we walk and come to understand how to interface some of these chips to external components.

In this Transistor Circuits ebook, we have presented about 100 interesting circuits using transistors and chips.

In most cases the IC will contain 10 - 100 transistors, cost less than the individual components and take up much less board-space. They also save a lot of circuit designing and quite often consume less current than discrete components.

In all, they are a fantastic way to get something working with the least componentry.

A list of Integrated Circuits (Chips) is provided at the end of this book to help you identify the pins and show you what is inside the chip.

Some of the circuits are available from Talking Electronics as a kit, but others will have to be purchased as individual components from your local electronics store. Electronics is such an enormous field that we cannot provide kits for everything. But if you have a query about one of the circuits, you can contact me.

Colin Mitchell  
TALKING ELECTRONICS.  
[talking@tpg.com.au](mailto:talking@tpg.com.au)

To save space we have not provided lengthy explanations of how the circuits work. This has already been covered in TALKING ELECTRONICS Basic Electronics Course, and can be obtained on a [CD for \\$10.00](#) (posted to anywhere in the world) See Talking Electronics website for more details: <http://www.talkingelectronics.com>

## MORE INTRO

There are two ways to learn electronics.

One is to go to school and study theory for 4 years and come out with all the theoretical knowledge in the world but almost no practical experience.

We know this type of person. We employed them (for a few weeks!). They think everything they design WILL WORK because their university professor said so.

The other way is to build circuit after circuit and get things to work. You may not know the in-depth theory of how it works but trial and error gets you there.

We know. We employed this type of person for up to 12 years.

I am not saying one is better than the other but most electronics enthusiasts are not "book worms" and anyone can succeed in this field by constantly applying themselves to constructing projects. You actually learn 10 times faster by applying yourself and we have had technicians repairing equipment after only a few weeks on the job. It would be nothing for an enthusiast to build 30 - 40 circuits from our previous Transistor eBook and a similar number from this book. Many of the circuits are completely different to each other and all have a building block or two that you can learn from.

Electronics enthusiasts have an uncanny understanding of how a circuit works and if you have this ability, don't let it go to waste.

Electronics will provide you a comfortable living for the rest of your life and I mean this quite seriously. The market is very narrow but new designs are coming along all the time and new devices are constantly being invented and more are always needed.

Once you get past this eBook of "Chips and Transistors" you will want to investigate microcontrollers and this is when your options will explode.

You will be able to carry out tasks you never thought possible, with a chip as small as 8 pins and a few hundred lines of code.

As I say in my speeches. What is the difference between a "transistor man" and a "programmer?" TWO WEEKS!

In two weeks you can start to understand the programming code for a microcontroller and perform simple tasks such as flashing a LED and produce sounds and outputs via the press of a button.

All these things are covered on [Talking Electronics website](#) and you don't have to buy any books or publications. Everything is available on the web and it is instantly accessible. That's the beauty of the web. Don't think things are greener on the other side of the fence, by buying a text book. They aren't. Everything you need is on the web AT NO COST.

The only thing you have to do is build things. If you have any technical problem at all, simply email [Colin Mitchell](mailto:Colin Mitchell) and any question will be answered. Nothing could be simpler and this way we

guarantee you SUCCESS. Hundreds of readers have already emailed and after 5 or more emails, their circuit works. That's the way we work. One thing at a time and eventually the fault is found. If you think a circuit will work the first time it is turned on, you are fooling yourself.

All circuits need corrections and improvements and that's what makes a good electronics person. Don't give up. How do you think all the circuits in these eBooks were designed? Some were copied and some were designed from scratch but all had to be built and adjusted slightly to make sure they worked perfectly.

I don't care if you use bread-board, copper strips, matrix board or solder the components in the air as a "bird's nest." You only learn when the circuit gets turned on and WORKS!

In fact the rougher you build something, the more you will guarantee it will work when built on a printed circuit board.

However, high-frequency circuits (such as 100MHz FM Bugs) do not like open layouts and you have to keep the construction as tight as possible to get them to operate reliably.

In most other cases, the layout is not critical.

## TRANSISTORS

Most of the transistors used in our circuits are BC 547 and BC 557. These are classified as "universal" or "common" NPN and PNP types with a voltage rating of about 25v, 100mA collector current and a gain of about 100.

You can use almost any type of transistor to replace them and here is a list of the equivalents and pinouts:

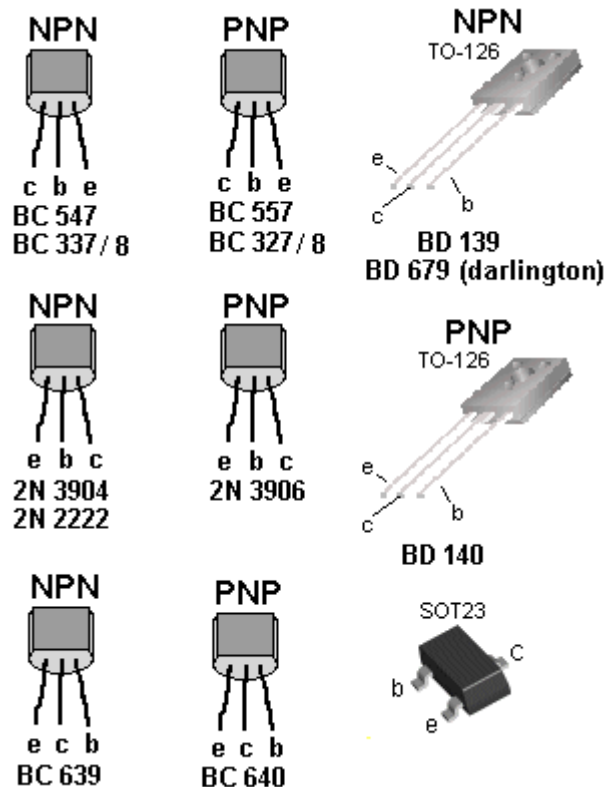

## CONTENTS

[Alarm Using 4 buttons](#)

[Phase-Shift Oscillator](#) - good design

<a href="#">Audio Amplifier (mini)</a>	<a href="#">Phone Bug</a>
<a href="#">Battery Monitor MkI</a>	<a href="#">Phone Tape-3</a>
<a href="#">Battery Monitor MkII</a>	<a href="#">Power ON</a>
<a href="#">Bike Turning Signal</a>	<a href="#">Power Supplies - Fixed</a>
<a href="#">Beacon (Warning Beacon 12v)</a>	<a href="#">Power Supplies - Adjustable</a> LMxx series
<a href="#">Beeper Bug</a>	<a href="#">Power Supplies - Adjustable</a> 78xx series
<a href="#">Blocking Oscillator</a>	<a href="#">Power Supplies - Adjustable from 0v</a>
<a href="#">Book Light</a>	<a href="#">PWM Controller</a>
<a href="#">Camera Activator</a>	<a href="#">Quiz Timer</a>
<a href="#">Capacitor Discharge Unit MkII (CDU2) Trains</a>	<a href="#">Railway time</a>
<a href="#">Car Detector (loop Detector)</a>	<a href="#">Random Blinking LEDs</a>
<a href="#">Circuit Symbols</a> Complete list of Symbols	<a href="#">Resistor Colour Code</a>
<a href="#">Clap Switch</a>	<a href="#">Resistor Colour Code - 4, 5 and 6 Bands</a>
<a href="#">Code Lock</a>	<a href="#">Reversing a Motor</a>
<a href="#">Colour Code for Resistors - all resistors</a>	<a href="#">Sequencer</a>
<a href="#">Constant Current</a>	<a href="#">Shake Tic Tac LED Torch</a>
<a href="#">Dark Detector with beep Alarm</a>	<a href="#">Simple Flasher</a>
<a href="#">Decaying Flasher</a>	<a href="#">Simple Touch-ON Touch-OFF Switch</a>
<a href="#">Fading LED</a>	<a href="#">Siren</a>
<a href="#">Flasher (simple)</a>	<a href="#">Soft Start power supply</a>
<a href="#">Flashing Beacon (12v Warning Beacon)</a>	<a href="#">Telephone Bug</a>
<a href="#">Hex Bug</a>	<a href="#">Touch-ON Touch-OFF Switch</a>
<a href="#">H-Bridge</a>	<a href="#">Tracking Transmitter</a>
<a href="#">Increasing the output current</a>	<a href="#">Track Polarity - model railway</a>
<a href="#">Intercom</a>	<a href="#">Train Detectors</a>
<a href="#">Latching Relay</a>	<a href="#">Transformerless Power Supply</a>
<a href="#">LED Detects light</a>	<a href="#">Vehicle Detector</a> loop Detector
<a href="#">Limit Switches</a>	<a href="#">Voltage Multipliers</a>
<a href="#">Low fuel Indicator</a>	<a href="#">Wailing Siren</a>
<a href="#">Low Voltage Flasher</a>	<a href="#">1-watt LED</a>
<a href="#">Mains Night Light</a>	<a href="#">1.5 watt LED</a>
<a href="#">Make any resistor value</a>	<a href="#">3-Phase Generator</a>
<a href="#">Model Railway time</a>	<a href="#">5v from old cells</a>
	<a href="#">12v Flashing Beacon (Warning Beacon)</a>
	<a href="#">20 LEDs on 12v supply</a>

## RESISTOR COLOUR CODE

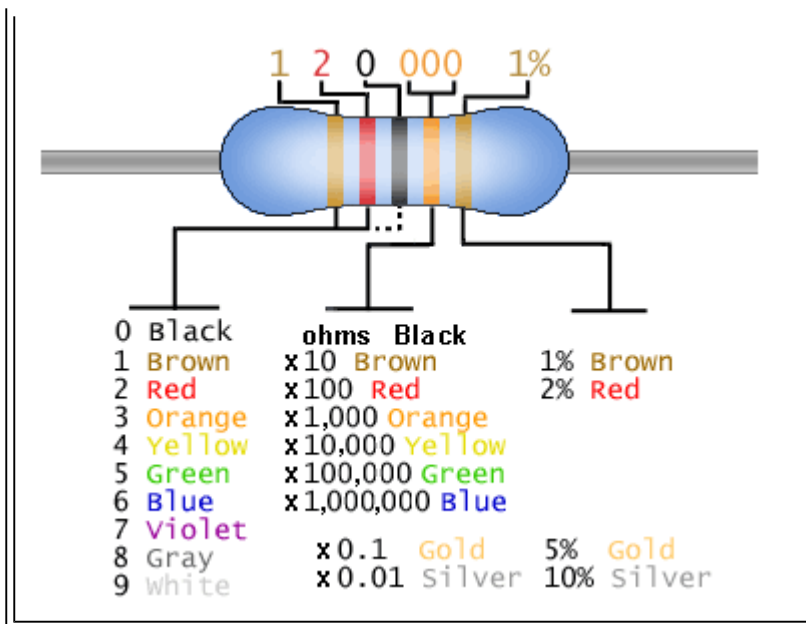

See [resistors from 0.22ohm to 22M](#) in full colour at end of book and another [resistor table](#)

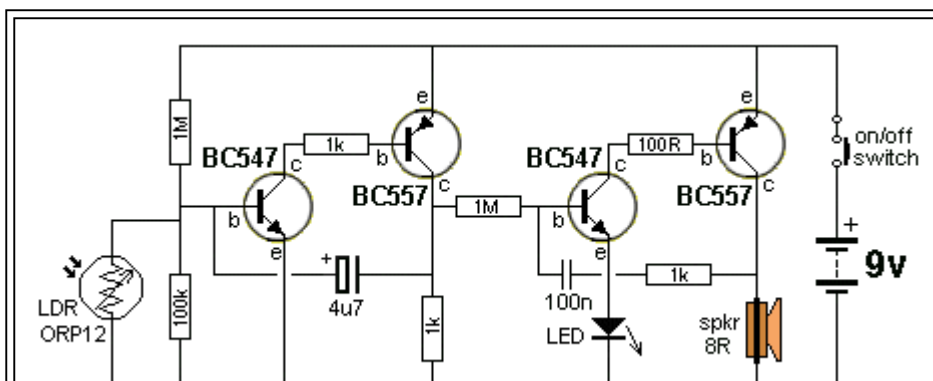

**DARK DETECTOR with beep-beep-beep Alarm**

This circuit detects darkness and produces a beep-beep-beep alarm. The first two transistors form a high-gain amplifier with feedback via the 4u7 to produce a low-frequency oscillator. This provides voltage for the second oscillator (across the 1k resistor) to drive a speaker.

[to Index](#)

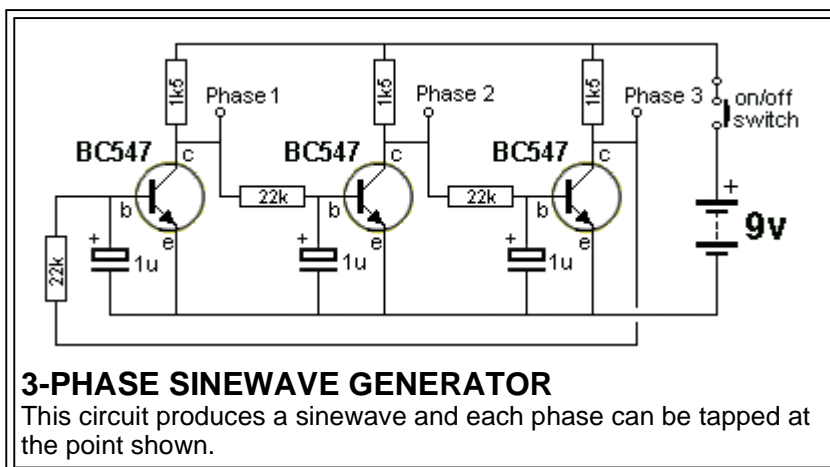

**3-PHASE SINEWAVE GENERATOR**

This circuit produces a sinewave and each phase can be tapped at the point shown.

[to Index](#)



**TRANSFORMERLESS POWER SUPPLY**

This clever design uses 4 diodes in a bridge to produce a fixed voltage power supply capable of supplying 35 **All diodes** (every type of diode) are zener diodes. They all break down at a particular voltage. The fact is, a  $\mu$  diode breaks down at 100v or 400v and its zener characteristic is not useful. But if we put 2 zener diodes in a bridge with two ordinary power diodes, the bridge will break-down at the volt zener. This is what we have done. If we use 18v zeners, the output will be 17v4. When the incoming voltage is positive at the top, the left zener provides 18v limit (and the left power-diode pr drop of 0.6v). This allows the right zener to pass current just like a normal diode but the voltage available to it 18v. The output of the right zener is 17v4. The same with the other half-cycle. The current is limited by the value of the X2 capacitor and this is 7mA for each 100n when in full-wave (as pe circuit). We have  $10 \times 100n = 1\mu$  capacitance. Theoretically the circuit will supply 70mA but we found it will or 35mA before the output drops. The capacitor should comply with X1 or X2 class. The 10R is a safety-fuse res. The problem with this power supply is the "live" nature of the negative rail. When the power supply is connect shown, the negative rail is 0.7v above neutral. If the mains is reversed, the negative rail is 340v (peak) above and this will kill you as the current will flow through the diode and be lethal. You need to touch the negative rail positive rail) and any earthed device such as a toaster to get killed. The only solution is the project being pow be totally enclosed in a box with no outputs.

[to Index](#)

**BOOK LIGHT**

This circuit keeps the globe illuminated for a few seconds after the switch is pressed. There is one minor fault in the circuit. The 10k should be increased to 100k to increase the "ON" time. The photo shows the circuit built with surface-mount components:

[to Index](#)

**CAMERA ACTIVATOR**

This circuit was designed for a customer who wanted to trigger a camera after a

short delay.

The output goes HIGH about 2 seconds after the switch is pressed. The LED turns on for about 0.25 seconds.

The circuit will accept either active HIGH or LOW input and the switch can remain pressed and it will not upset the operation of the circuit. The timing can be changed by adjusting the 1M trim pot and/or altering the value of the 470k.

[to Index](#)

## MAKE YOUR OWN:

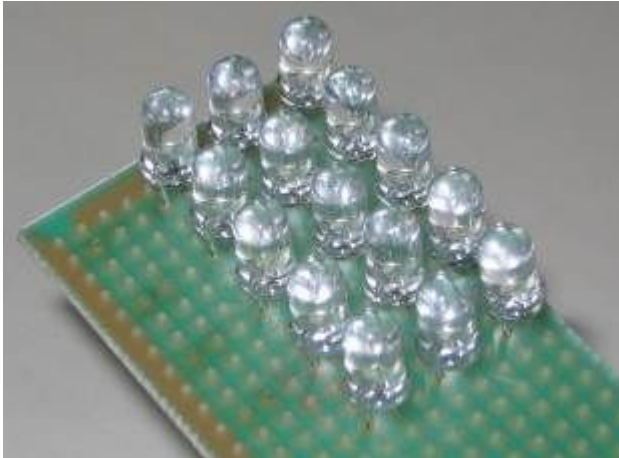

15 LEDs on Matrix board



The transformer consists of 50 turns 0.25mm wire connected to the pins. The feedback winding is 20 turns 0.095mm wire with "fly-leads."

## 1-WATT LED

This circuit drives 15 LEDs to produce the same brightness as a 1-watt LED. The circuit consumes 750mW but the LEDs are driven with high-frequency, high-voltage spikes, and become more-efficient and produce a brighter output than if driven by pure-DC.

The LEDs are connected in 3 strings of 5 LEDs. Each LED has a characteristic voltage of 3.2v to 3.6v making each chain between 16v and 18v. By selecting the LEDs we have produced 3 chains of 17.5v. Five LEDs (in a string) has been done to allow the circuit to be powered by a 12v battery and allow the battery to be charged while the LEDs are illuminating. If only 4 LEDs are in series, the characteristic voltage may be as low as 12.8v and they may be over-driven when the battery is charging. (Even-up the characteristic voltage across each chain by checking the total voltage across them with a 19v supply and 470R dropper resistor.) The transformer is shown above. It is wound on a 10mH choke with the original winding removed. This circuit is called a **"boost circuit."** It is not designed to drive a single 1-watt LED (a buck circuit is needed).

The LEDs in the circuit are 20,000mcd with a viewing angle of 30 degrees (many of the LED specifications use "half angle." You have to test a LED to make sure of the angle). This equates to approximately 4 lumens per LED. The 4-watt CREE LED claims 160 lumens (or 40 lumens per watt). Our design is between 50 - 60 lumens per watt and it is a much-cheaper design.

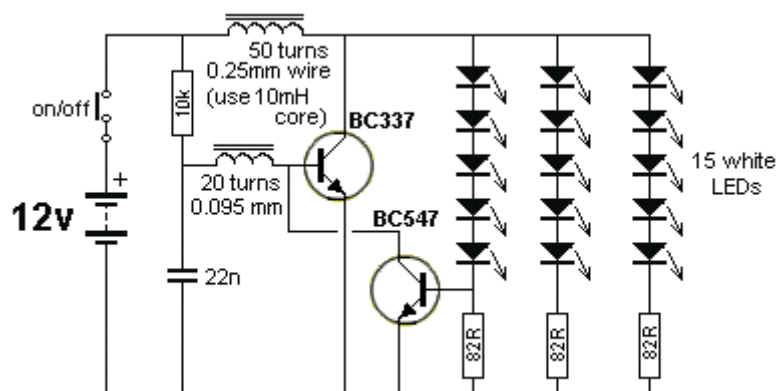

[to Index](#)



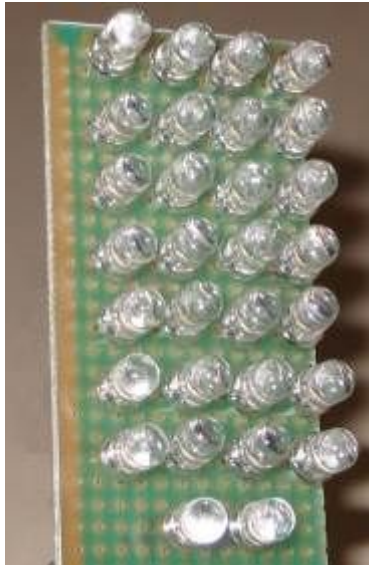

30 LEDs on Matrix board

### 1.5 WATT LED

The circuit below can be modified to drive up to 30 white LEDs.

The effectiveness of a LED array increases when they are spread out slightly and this makes them more efficient than a single 1 watt or 2 watt LED.

The two modifications to the circuit make the BC337 work harder and this is the limit of the inductor. The current consumption is about 95mA.

The winding details for the transformer are shown above.

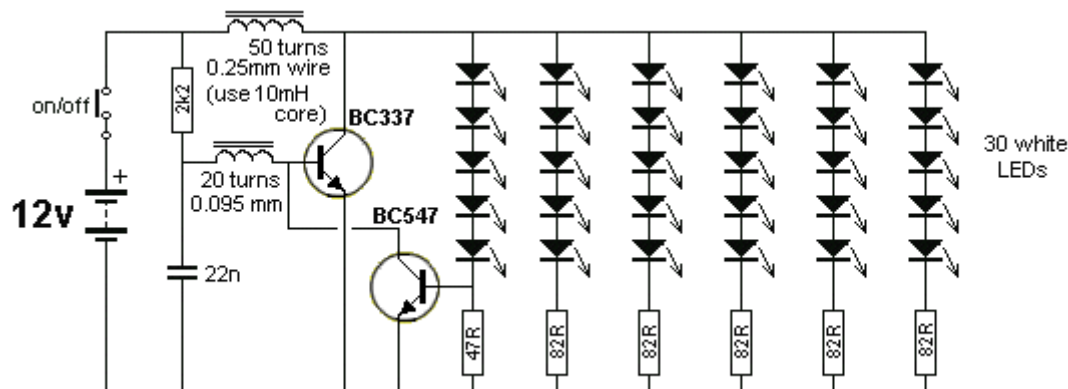

[to Index](#)

### DRIVE 20 LEDs FROM 12v - approx 1watt circuit

This is another circuit that drives a number of LEDs or a single 1 watt LED. It is a "Buck Circuit" and drives the LEDs in parallel. They should be graded so that the characteristic voltage-drop across each of them is within 0.2v of all the other LEDs. The circuit will drive any number from 1 to 20 by changing the "sensor" resistor as shown on the circuit. The current consumption is about 95mA @ 12v and lower at 18v. The circuit can be put into dim mode by increasing the drive resistor to 2k2. The UF4004 is an ultra fast 1N4004 - similar to a high-speed diode. You can use 2 x 1N4148 signal diodes.



The circuit will not drive two LEDs in series - it runs out of voltage (and current) when the voltage across the load is 7v. It oscillates at approx 200kHz. Build both the 20 LED and 1 watt LED version and compare the brightness and effectiveness. The photo of the 1 watt LED on the left must be heatsinked to prevent the LED overheating. The photo on the circuit diagram shows the LED mounted on a heatsink and the connecting wires.



**A 1-watt demo board showing the complex step-up circuitry.**

This is a Boost circuit to illuminate the LED and is completely different to our design. It has been included to show the size of a 1 watt LED.

The reason for a Boost or Buck circuit to drive one or more LEDs is simple. The voltage across a LED is called a "characteristic voltage" and comes as a natural feature of the LED. We cannot alter it. To power the LED with exactly the correct amount of voltage (and current) you need a supply that is EXACTLY the same as the characteristic voltage. This is very difficult to do and so a resistor is normally added in series. But this resistor wastes a lot of energy. So, to keep the losses to a minimum, we pulse the LED with bursts of energy at a higher voltage and the LED absorbs them and produces light. With a Buck circuit, the transistor is turned on for a short period of time and illuminated the LEDs. At the same time, some of the energy is passed to the inductor so that the LEDs are not damaged. When the transistor is turned off, the energy from the inductor also gives a pulse of energy to the LEDs. When this has been delivered, the cycle starts again.

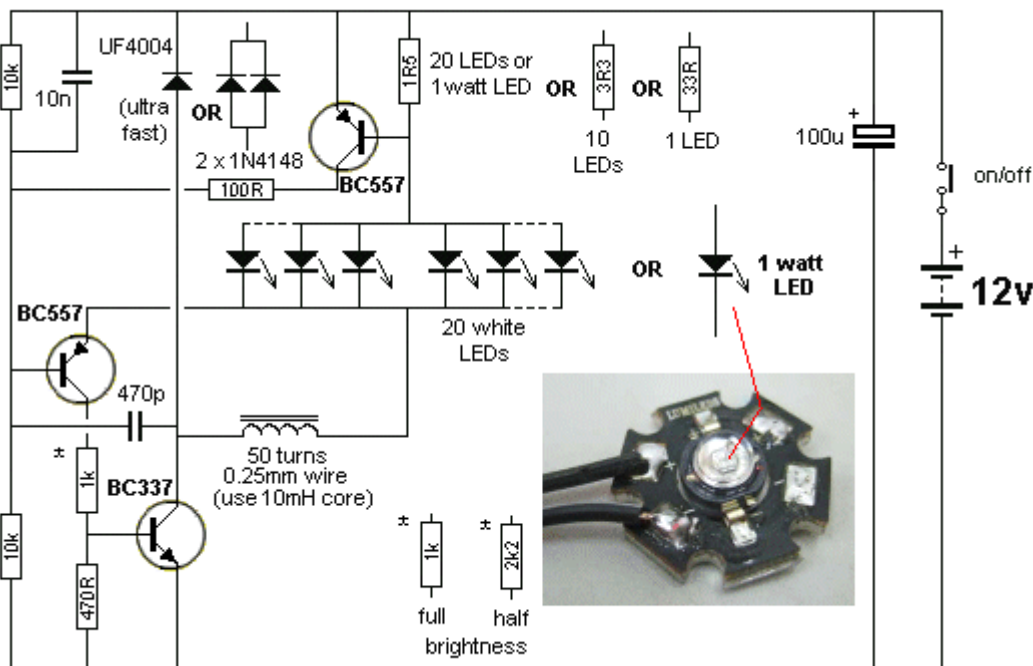

[to Index](#)

**POWER SUPPLIES - FIXED:**

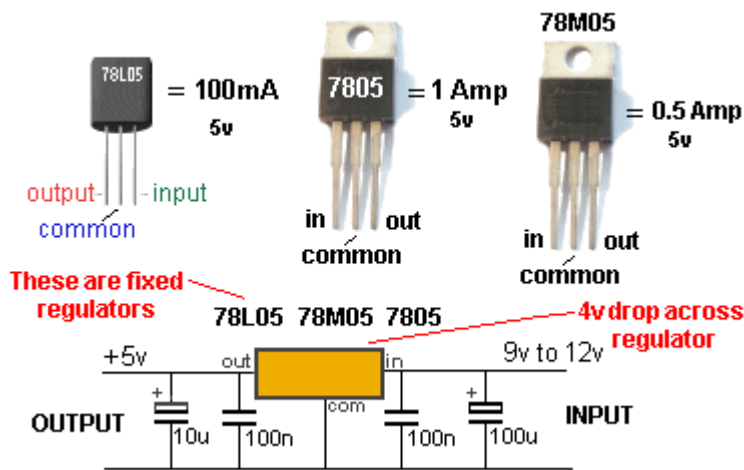

A simple power supply can be made with a component called a "3-pin regulator or 3-terminal regulator" It will provide a very low ripple output (about 4mV to 10mV provided electrolytics are on the input and output.

The diagram above shows how to connect a regulator to create a power supply. The 7805 regulators can handle 100mA, 500mA and 1 amp, and produce an output of 5v, as shown.

These regulators are called **linear regulators** and drop about 4v across them - minimum. If the current flow is 1 amp, 4watts of heat must be dissipated via a large heatsink. If the output is 5v and input 12v, 7volts will be dropped across the regulator and 7watts must be dissipated.

[to Index](#)

**POWER SUPPLIES - ADJUSTABLE:**

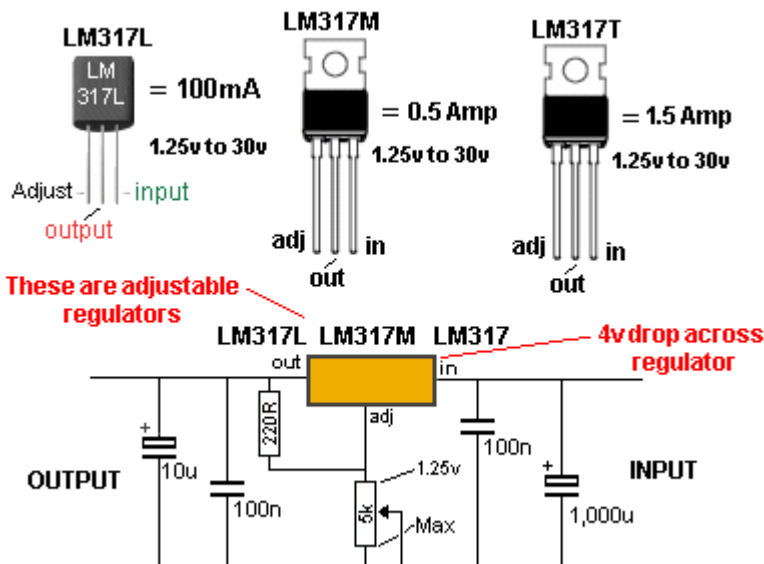

The LM317 regulators are adjustable and produce an output from 1.25 to about 35v. The LM317T regulator will deliver up to 1.5amp.

[to Index](#)

**POWER SUPPLIES - ADJUSTABLE using 7805:**

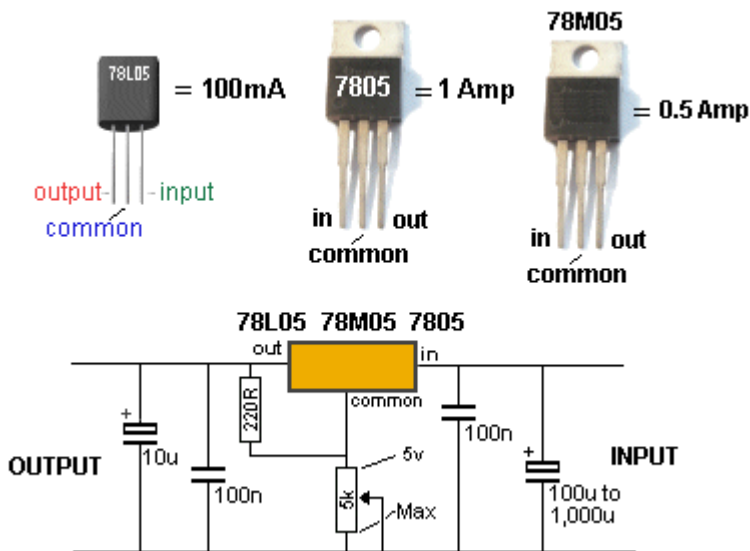

The 7805 range of regulators are called "fixed regulators" but they can be turned into adjustable regulators by "jacking-up" their output voltage. For a 5v regulator, the output can be 5v to 30v.

[to Index](#)

**POWER SUPPLIES - ADJUSTABLE from 0v:**

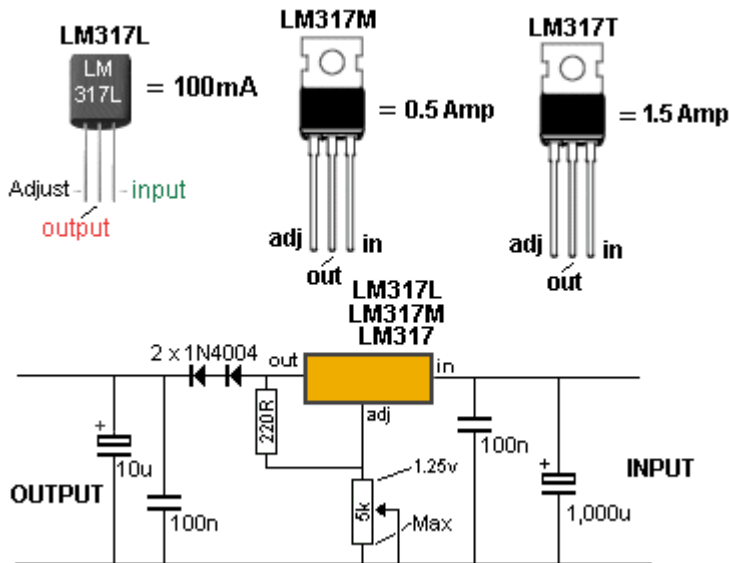

The LM317 regulator is adjustable from 1.25 to about 35v. To make the output 0v to 35v, two power diodes are placed as shown in the circuit. Approx 0.6v is dropped across each diode and this is where the 1.25v is "lost."

[to Index](#)

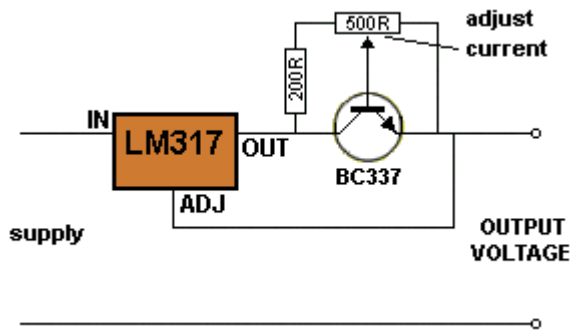

**CONSTANT CURRENT**

This constant current circuit can be adjusted to any value from a few milliamp to about 500mA - this is the limit of the BC337 transistor.

The circuit can also be called a current-limiting circuit and is ideal in a bench power supply to prevent the circuit you are testing from being damaged.

Approximately 4v is dropped across the regulator and 1.25v across the current-limiting section, so the input voltage (supply) has to be 5.25v above the required output voltage. Suppose you want to charge 4 Ni-Cad cells. Connect them to the output and adjust the 500R pot until the required charge-current is obtained.

The charger will now charge 1, 2, 3 or 4 cells at the same current. But you must remember to turn off the charger before the cells are fully charged as the circuit will not detect this and over-charge the cells.

The LM 317 3-terminal regulator will need to be heatsinked.

This circuit is designed for the LM series of regulator as they have a voltage differential of 1.25v between "adj" and "out" terminals.

7805 regulators can be used but the losses in the BC337 will be 4 times greater as the voltage across it will be 5v.

[to Index](#)

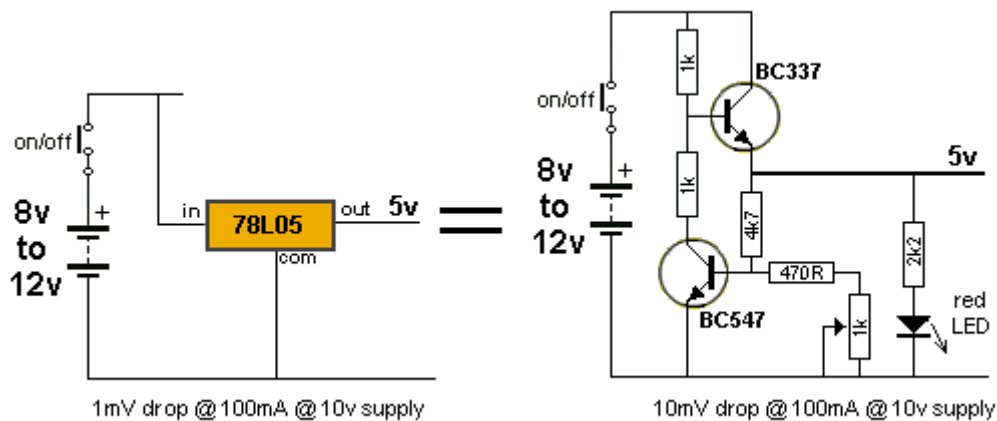



**The regulator connected to a 12v battery pack**



**The regulator connected to a 9v battery**



The battery snap plugs into the pins on the 5v regulator board with the red lead going to the negative output of the board as the battery snap is now DELIVERING voltage to the circuit you are powering.

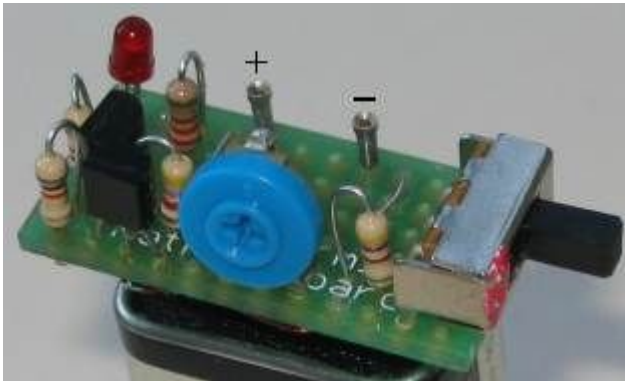

**A close-up of the regulator module**

### 5v FROM OLD CELLS

This circuit takes the place of a 78L05 3-terminal regulator. It produces a constant 5v @ 100mA. You can use any old cells and get the last of their energy. Use an 8-cell holder. The voltage from 8 old cells will be about 10v and the circuit will operate down to about 7.5v. The regulation is very good at 10v, only dropping about 10mV for 100mA current flow (the 78L05 has 1mV drop). As the voltage drops, the output drops from 5v on no-load to 4.8v and 4.6v on 100mA current-flow. The pot can be adjusted to compensate for the voltage-drop.

[to Index](#)

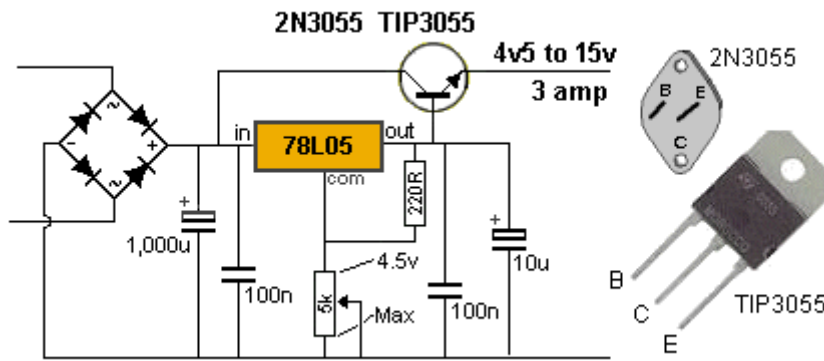

**INCREASING THE OUTPUT CURRENT**

The output current of all 3-terminal regulators can be increased by including a pass transistor. This transistor simply allows the current to flow through the collector-emitter leads. The output voltage is maintained by the 3-terminal regulator but the current flows through the "pass transistor." This transistor is a power transistor and must be adequately heatsinked. Normally a 2N3055 or TIP3055 is used for this application as it will handle up to 10 amps and creates a 10 amp power supply. The regulator can be 78L05 as all the current is delivered by the pass transistor.

[to Index](#)

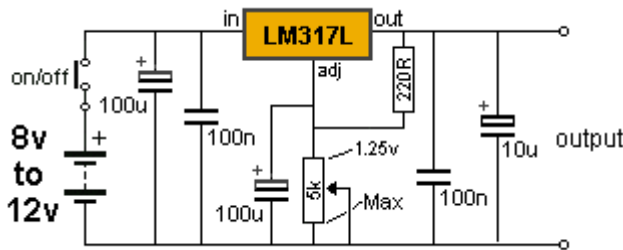

**SOFT START**

The output voltage of a 3-terminal regulator can be designed to rise slowly. This has very limited application as many circuits do not like this.

[to Index](#)

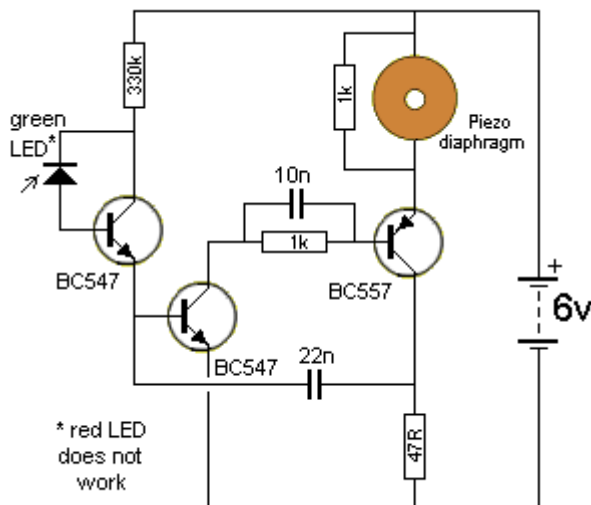

**LED DETECTS LIGHT**

The LED in this circuit will detect light to turn on the oscillator. Ordinary red LEDs do not work. But green LEDs, yellow LEDs and high-bright white LEDs and high-bright red

LEDs work very well.

The output voltage of the LED is up to 600mV when detecting very bright illumination. When light is detected by the LED, its resistance decreases and a very small current flows into the base of the first transistor. The transistor amplifies this current about 200 times and the resistance between collector and emitter decreases. The 330k resistor on the collector is a current limiting resistor as the middle transistor only needs a very small current for the circuit to oscillate. If the current is too high, the circuit will "freeze." The piezo diaphragm does not contain any active components and relies on the circuit to drive it to produce the tone. A different **LED Detects Light** circuit in eBook 1:

[1 - 100 Transistor Circuits](#)

[to Index](#)

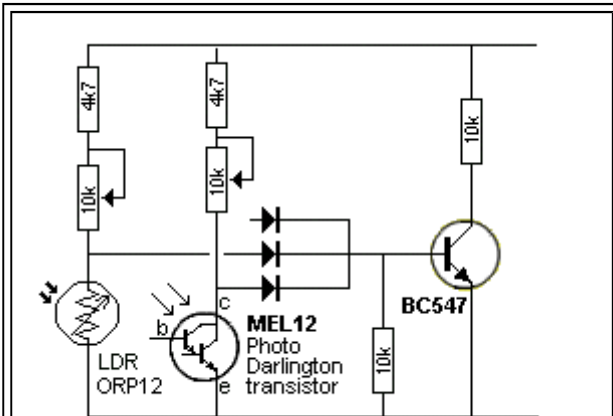

### TRAIN DETECTORS

In response to a reader who wanted to parallel TRAIN DETECTORS, here is a diode OR-circuit. The resistor values on each detector will need to be adjusted (changed) according to the voltage of the supply and the types of detector being used. Any number of detectors can be added. See Talking Electronics website for train circuits and kits including Air Horn, Capacitor Discharge Unit for operating point motors without overheating the windings, Signals, Pedestrian Crossing Lights and many more.

[to Index](#)

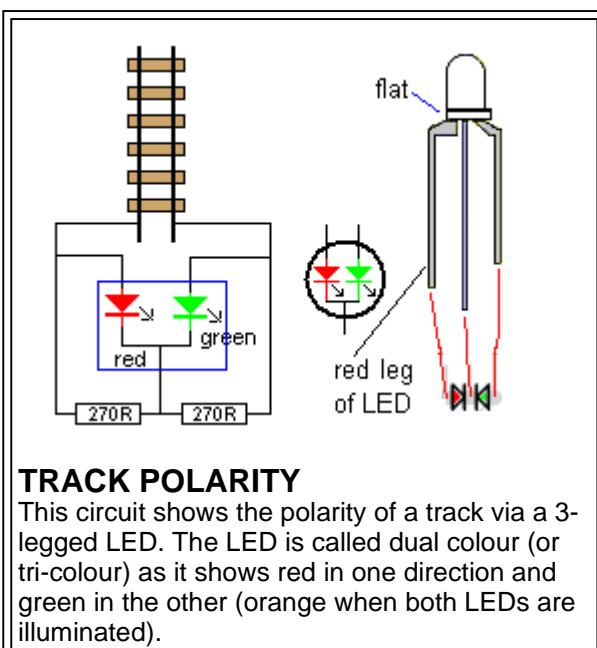

### TRACK POLARITY

This circuit shows the polarity of a track via a 3-legged LED. The LED is called dual colour (or tri-colour) as it shows red in one direction and green in the other (orange when both LEDs are illuminated).

[to Index](#)



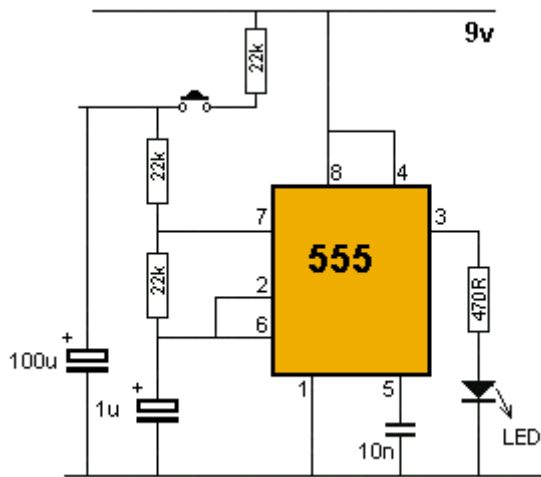

### DECAYING FLASHER

In response to a reader who wanted a flashing LED circuit that slowed down when a button was released, the above circuit increases the flash rate to a maximum and when the button is released, the flash rate decreases to a minimum and halts.

[to Index](#)

### SIMPLE FLASHER

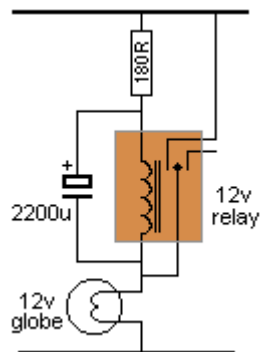

This simple circuit flashes a globe at a rate according to the value of the 180R and 2200u electrolytic.

[to Index](#)

### LATCHING RELAY

To reduce the current in battery operated equipment a relay called LATCHING RELAY can be used. This is a relay that latches itself ON when it receives a pulse in one direction and unlatches itself when it receives a pulse in the other direction.

The following diagram shows how the coil makes the magnet click in the two directions.

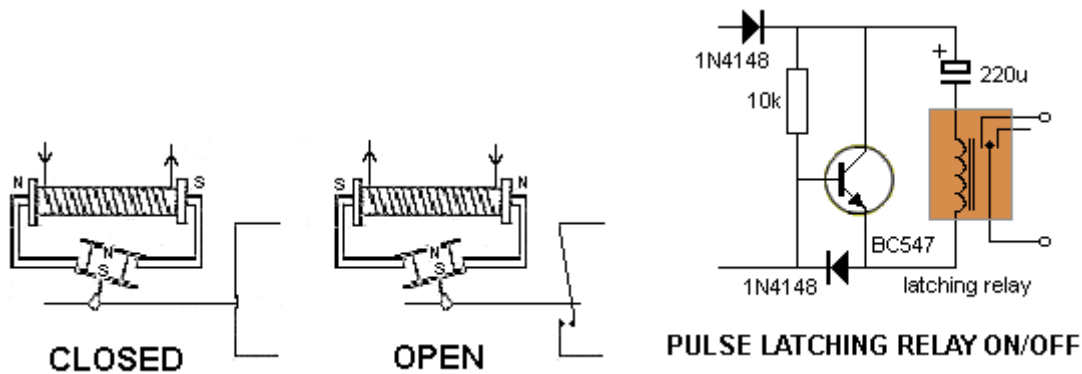

To operate this type of relay, the voltage must be reversed to unlatch it. The circuit above produces a strong pulse to latch the relay ON and the input voltage must remain HIGH. The 220uF gradually charges and the current falls to a very low level. When the input voltage is removed, the circuit produces a pulse in the opposite direction to unlatch the relay.

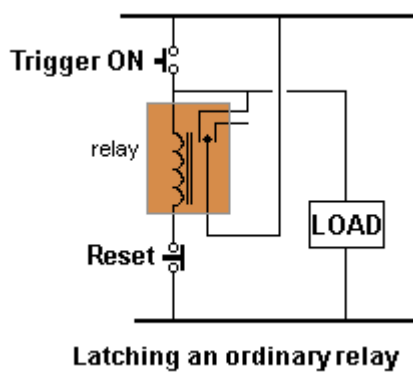

If you want to latch an ordinary relay so it remains ON after a pulse, the circuit at the left can be used. Power is needed all the time to keep the relay ON.

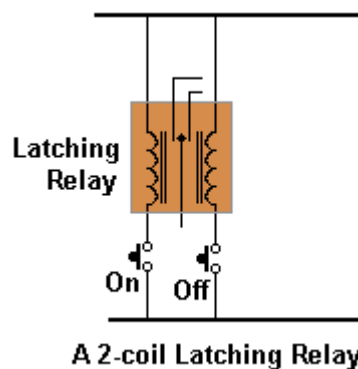

Latching Relays are expensive but a 5v Latching Relay is available from: [Excess Electronics](#) for \$1.00 as a surplus item. It has 2 coils and requires the circuit at the left. A 5v Latching Relay can be use on 12v as it is

activated for a very short period of time.

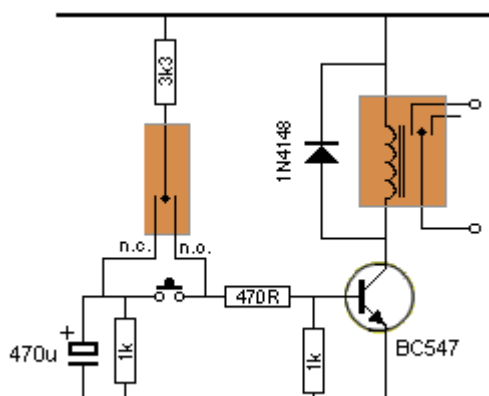

A double-pole (ordinary) relay and transistor can be connected to provide a toggle action. The circuit comes on with the relay de-activated and the contacts connected so that the 470uF charges via the 3k3. Allow the 470uF to charge. By pressing the button, the BC547 will activate the relay and the contacts will change so that the 3k3 is now keeping the transistor ON. The 470uF will discharge via the 1k. After a few seconds the electro will be discharged. If the press-button is now pushed for a short period of time, the transistor will turn off due to the electro being discharged.

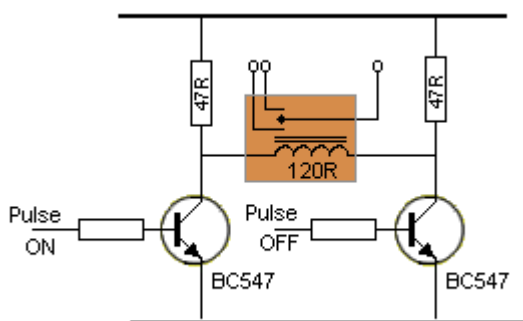

A single-coil latching relay normally needs a reverse-voltage to unlatch but the circuit at the left provides forward and reverse voltage by using 2 transistors in a very clever H-design. The pulse-ON and pulse-OFF can be provided from two lines of the microcontroller.

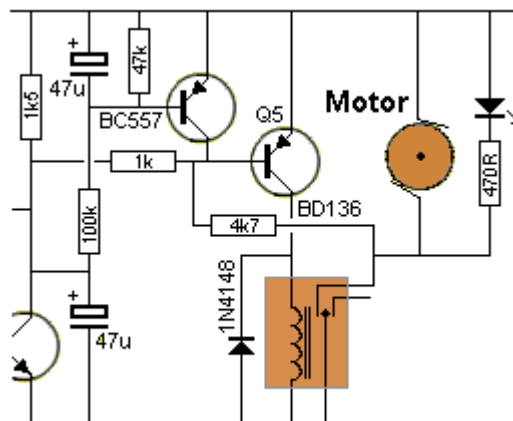

tone as shown via the circuit on the left. This circuit can be found in "27MHz Links" Page 2.

[to Index](#)

### REVERSING A MOTOR

There are a number of ways to reverse a motor. The following diagrams show how to connect a double-pole double throw relay or switch and a set of 4 push buttons. The two buttons must be pushed at the same time or two double pole push-switches can be used. See H-Bridge below for more ways to reverse a motor.

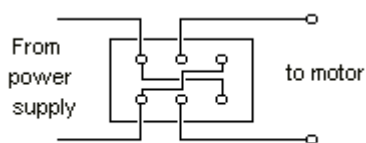

**double-pole double-throw relay**

Adding limit switches:

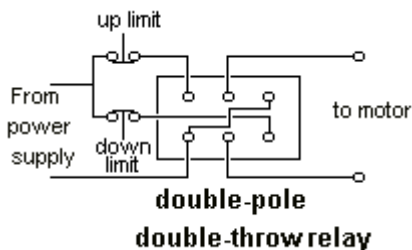

**double-pole double-throw relay**

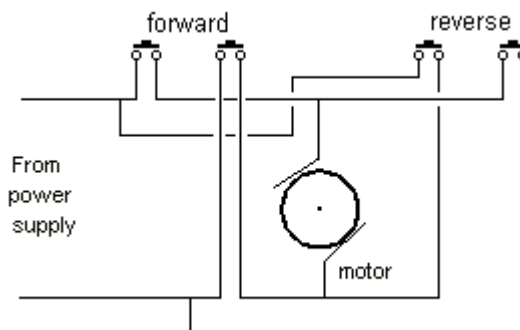

[to Index](#)

**BATTERY MONITOR MkI**

A very simple battery monitor can be made with a dual-colour LED and a few surrounding components. The LED produces orange when the red and green LEDs are illuminated. The following circuit turns on the red LED below 10.5v. The orange LED illuminates between 10.5v and 11.6v. The green LED illuminates above 11.6v

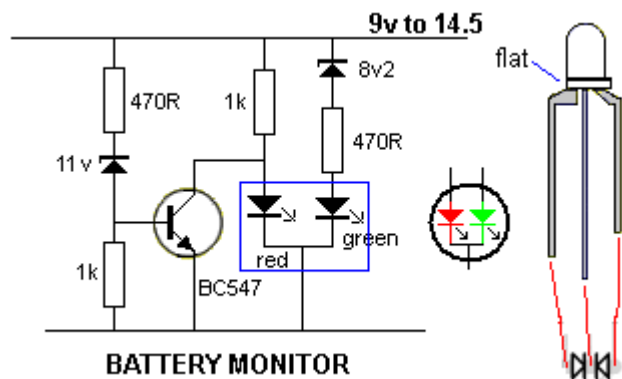

[to Index](#)

**BATTERY MONITOR MkII**

This battery monitor circuit uses 3 separate LEDs. The red LED turns on from 6v to below 11v. It turns off above 11v and. The orange LED illuminates between 11v and 13v. It turns off above 13v and. The green LED illuminates above 13v

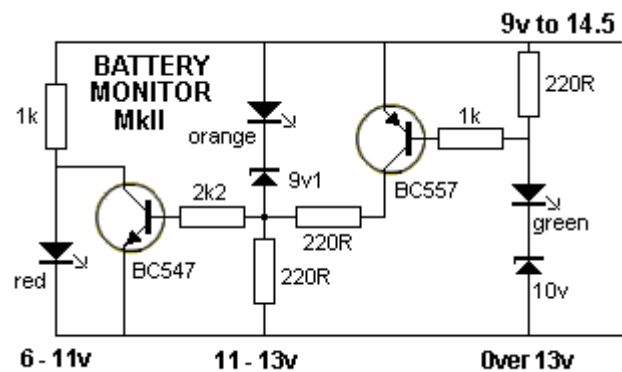

[to Index](#)

**LOW FUEL INDICATOR**

This circuit has been designed from a request by a reader. He wanted a low fuel indicator for his motorbike. The LED illuminates when the fuel gauge is 90 ohms. The tank is empty at 135 ohms and full at zero ohms.

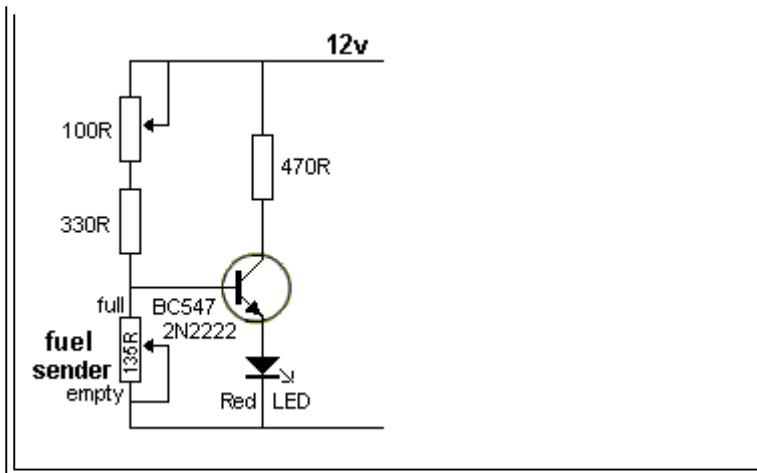

[to Index](#)

### QUIZ TIMER

This circuit can be used to indicate: "fastest finger first." It has a globe for each contestant and one for the Quiz Master.

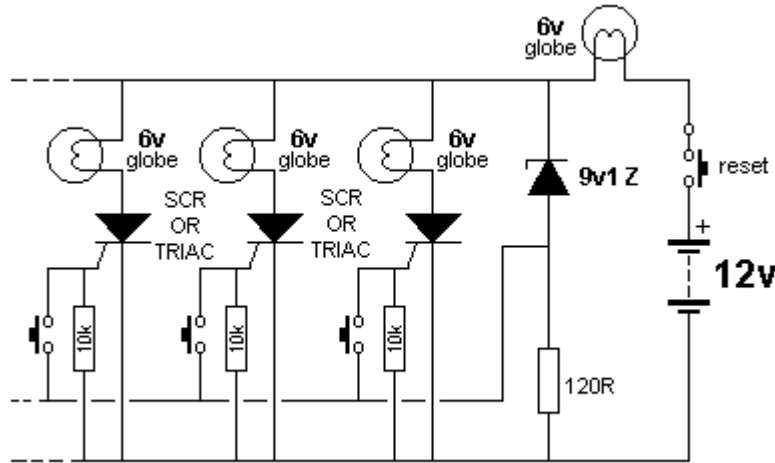

When a button is pressed the corresponding globe is illuminated. The Quiz Master globe is also illuminated and the cathode of the 9v1 zener sees approx mid-rail voltage. The zener comes out of conduction and no voltage appears across the 120R resistor. No other globes can be lit until the circuit is reset.

[to Index](#)

### TRACKING TRANSMITTER

This circuit can be used to track lots of items.

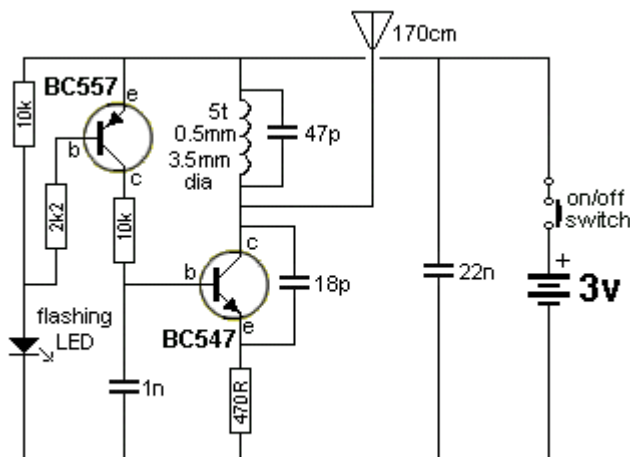

TRACKING TRANSMITTER MKI

It has a range of 200 - 400 metres depending on the terrain and the flashing LED turns the circuit ON when it flashes. The circuit consumes 5mA when producing a carrier (silence) and less than 1mA when off (background snow is detected).

[to Index](#)

### BIKE TURNING SIGNAL

This circuit can be used to indicate left and right turn on a motor-bike. Two identical circuits will be needed, one for left and one for right.

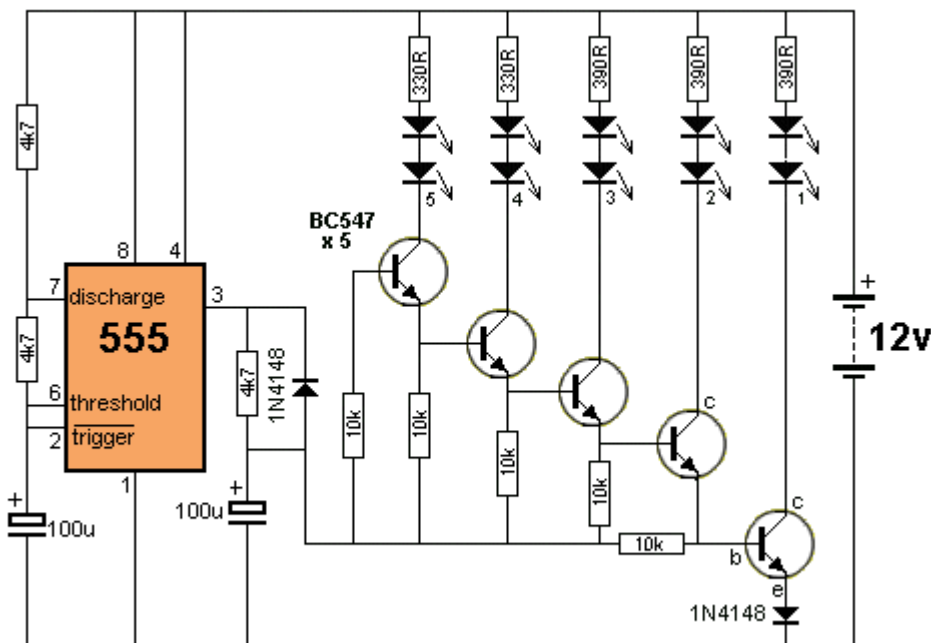

[to Index](#)

### PHONE TAPE-3

This circuit can be used to turn on a tape recorder when the phone line voltage is less than 15v. This is the approximate voltage when the handset is picked up. See Phone Tape-1 and Phone Tape-2 in **200 Transistor Circuits eBook (circuits 1 - 100)**. When the line voltage is above 25v, the BC547 is turned on and this robs the base of the second BC547 of the 1.2v it needs to turn on. When the line voltage drops, the first BC547 turns off and the 10uF charges via the 47k and gradually the second BC547 is turned on. This action turns on the BC338 and the resistance between its collector-emitter leads reduces. Two leads are taken from the BC338 to the "rem" (remote) socket on a tape recorder. When the lead is plugged into a tape recorder, the motor will stop. If the motor does not stop, a second remote lead has been included with the wires connected the opposite way. This lead will work. The audio for the tape recorder is also shown on the diagram. This circuit has the advantage that it does not need a battery. It will work on a 30v phone line as well as a 50v phone line.

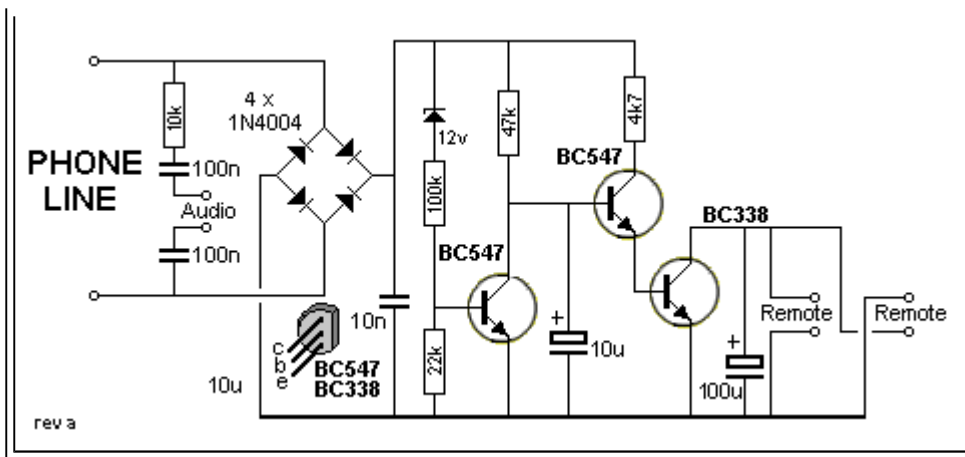

[to Index](#)

### SEQUENCER

This circuit has been requested by a reader. He wanted to have a display on his jacket that ran 9 LEDs then stopped for 3 seconds. The animated circuit shows this sequence:

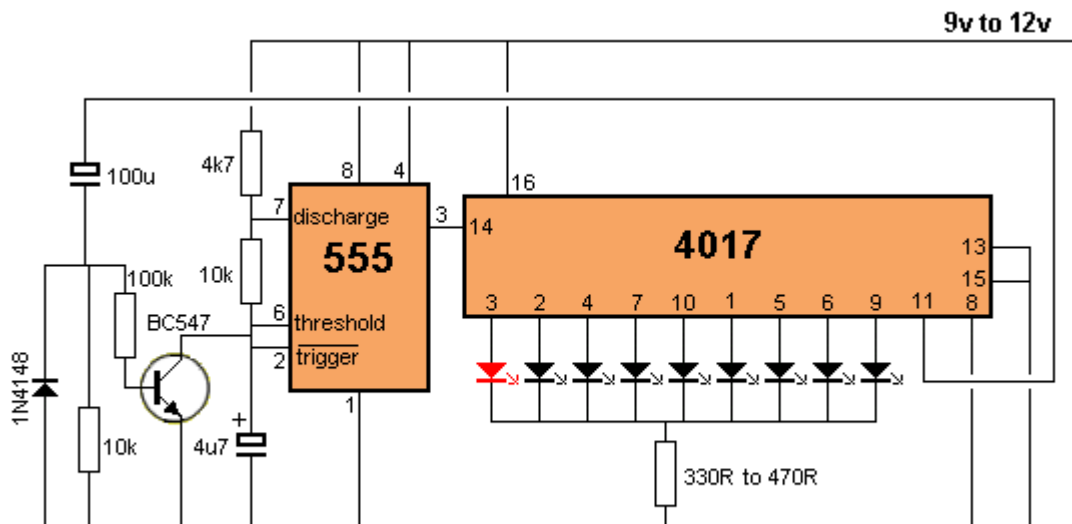

SEQUENCER WITH 3 SECOND INTERVAL

Note the delay produced by the 100u and 10k produces 3 seconds by the transistor inhibiting the 555 (taking pin 6 LOW). Learn more about the 555 - see the article: "The 555" on Talking Electronics website by clicking the title on the left index. See the article on CD 4017. See "Chip Data eBook" on TE website in the left index.

[to Index](#)

### H-BRIDGE

These circuits reverse a motor via two input lines. Both inputs must not be LOW with the first H-bridge circuit. If both inputs go LOW at the same time, the transistors will "short-out" the supply. This means you need to control the timing of the inputs. In addition, the current capability of some H-bridges is limited by the transistor types.

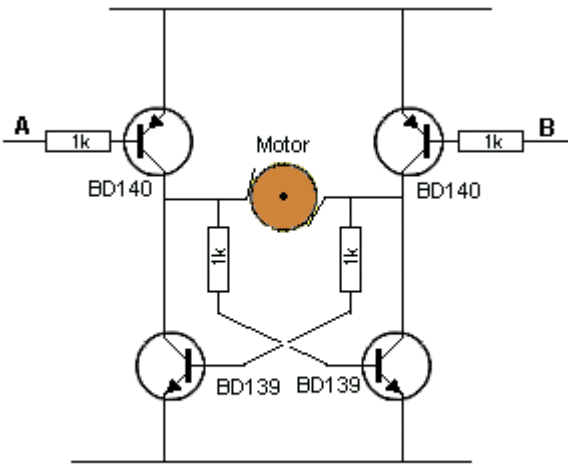

**A and B must NEVER both be low**

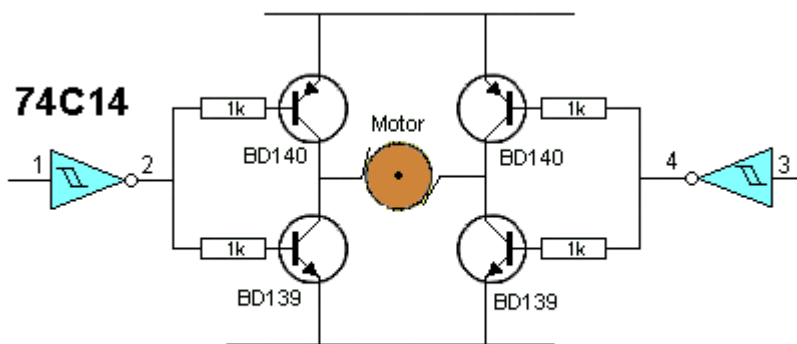

**When A and B are equal, motor does not run**

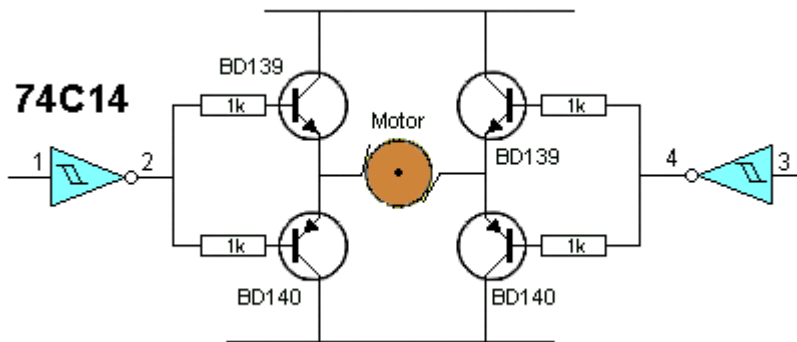

The driver transistors are in "emitter follower" mode in this circuit.

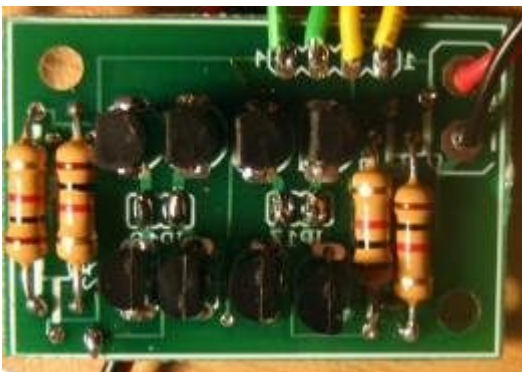

**Two H-Bridges on a PC board**



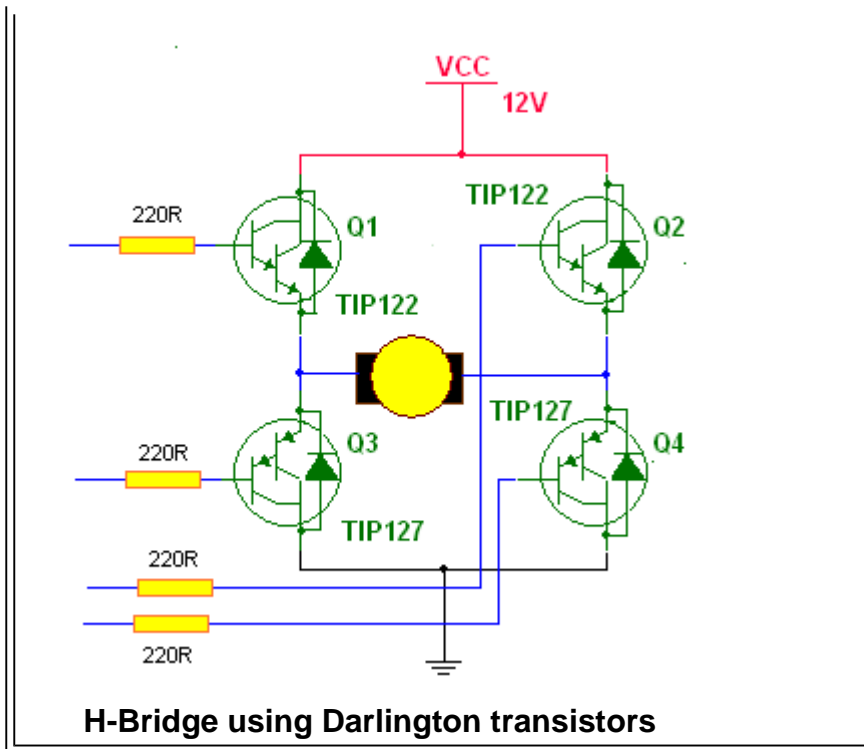

[to Index](#)

**TOUCH-ON TOUCH-OFF SWITCH**

This circuit will create a HIGH on the output when the Touch Plate is touched briefly and produce a low when the plate is touched again for a slightly longer period of time. Most touch switches rely on 50Hz mains hum and do not work when the hum is not present. This circuit does not rely on "hum."

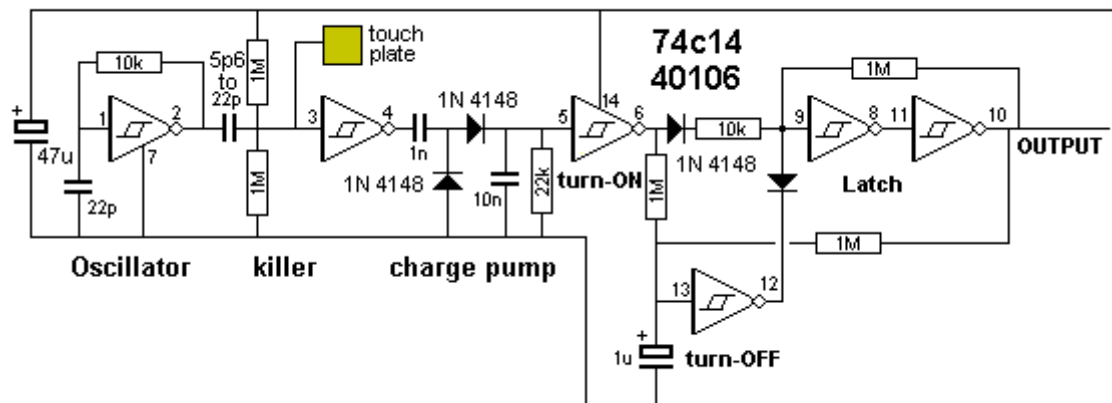

[to Index](#)

**SIMPLE TOUCH-ON TOUCH-OFF SWITCH**

This circuit will create a HIGH on the output when the Touch Plate is touched briefly and produce a low when the plate is touched again.

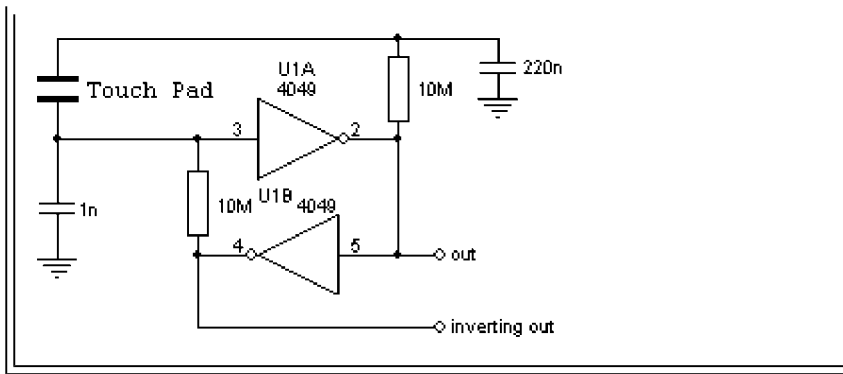

[to Index](#)

### SHAKE TIC TAC LED TORCH

In the diagram, it looks like the coils sit on the “table” while the magnet has its edge on the table. This is just a diagram to show how the parts are connected. The coils actually sit flat against the slide (against the side of the magnet) as shown in the diagram:

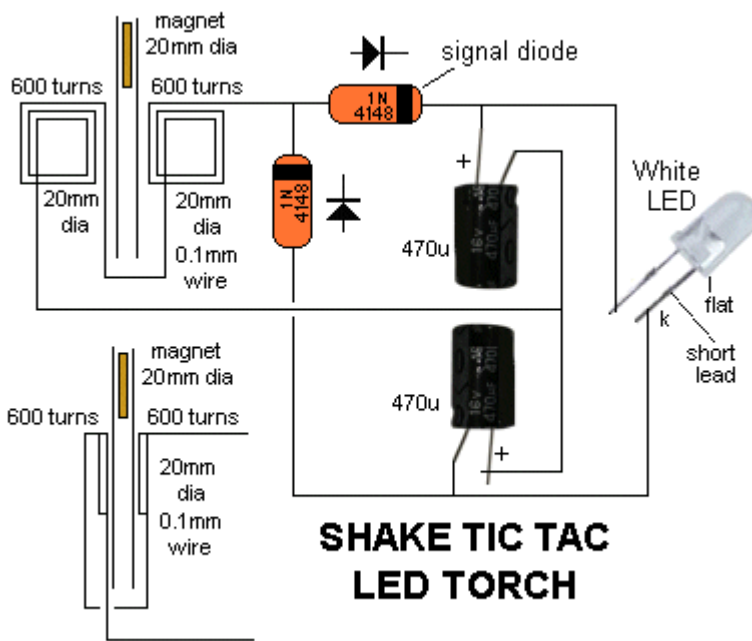

The output voltage depends on how quickly the magnet passes from one end of the slide to the other. That's why a rapid shaking produces a higher voltage. You must get the end of the magnet to fully pass through the coil so the voltage will be a maximum. That's why the slide extends past the coils at the top and bottom of the diagram.

The circuit consists of two 600-turn coils in series, driving a voltage doubler. Each coil produces a positive and negative pulse, each time the magnet passes from one end of the slide to the other. The positive pulse charges the top electrolytic via the top diode and the negative pulse charges the lower electrolytic, via the lower diode. The voltage across each electrolytic is combined to produce a voltage for

the white LED. When the combined voltage is greater than 3.2v, the LED illuminates. The electrolytics help to keep the LED illuminated while the magnet starts to make another pass.

[to Index](#)

### FADING LED

The circuit fades the LED ON and OFF at an equal rate. The 470k charging and 47k discharging resistors have been chosen to create equal on and off times.

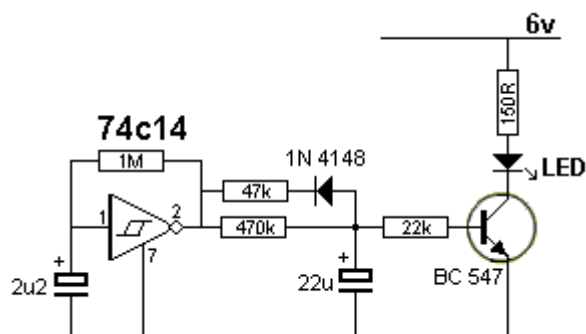

[to Index](#)

### MAINS NIGHT LIGHT

The circuit illuminates a column of 10 white LEDs. The 10u prevents flicker and the 100R also reduces flicker.

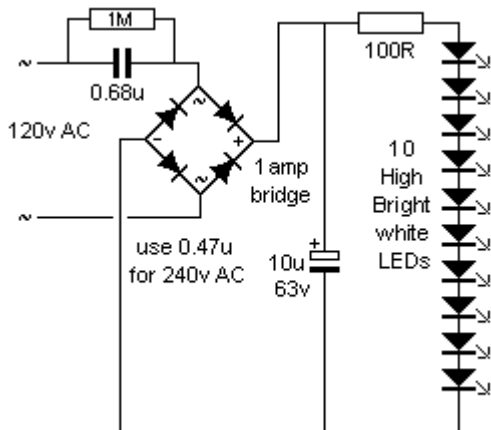

[to Index](#)

### RANDOM BLINKING LEDs

This circuit blinks a set of LEDs in a random pattern according to the slight differences in the three Schmitt Trigger oscillators. The CD4511 is BCD to 7-segment Driver

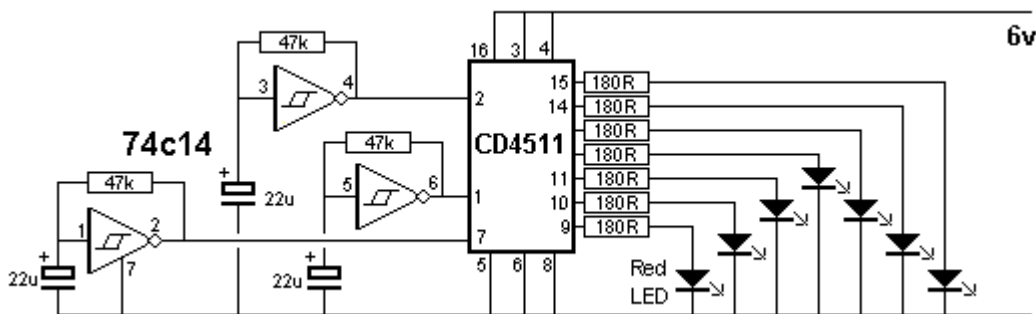

[to Index](#)

### HEX BUG

This is the circuit from a HEX BUG. It is a surface-mount bug with 6 legs. The pager motor is driven by an H-Bridge and "walks" to a wall where a feeler (consisting of a spring with a stiff wire down the middle) causes the motor to reverse.

In the forward direction, both sets of legs are driven by the compound gearbox but when the motor is reversed, the left legs do not operate as they are connected by a clutch consisting of a spring-loaded inclined plane that does not operate in reverse.

This causes the bug to turn around slightly.

The circuit also responds to a loud clap. The photo shows the 9 transistors and accompanying components:

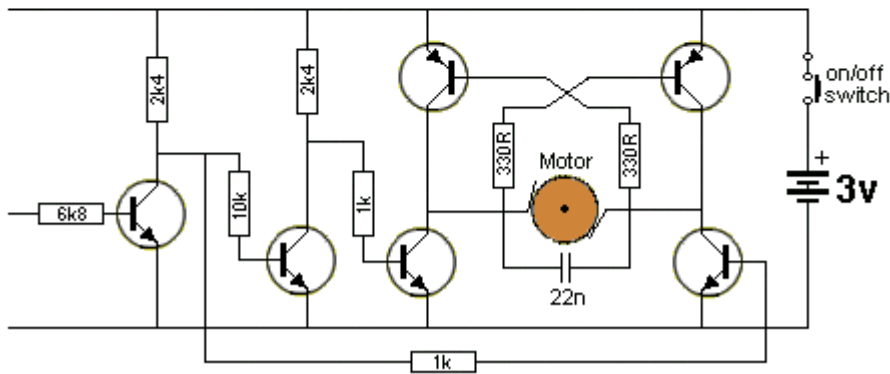
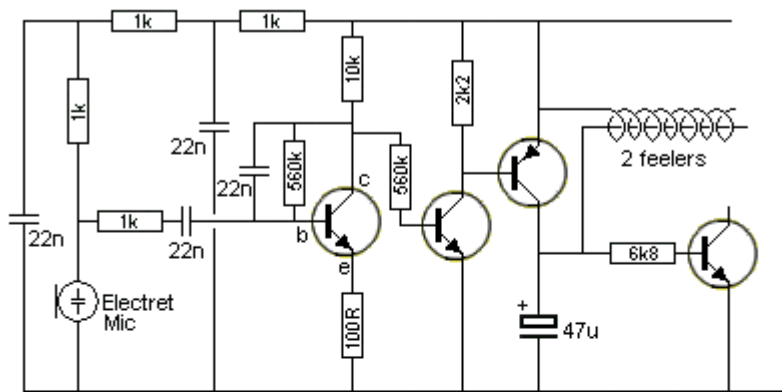
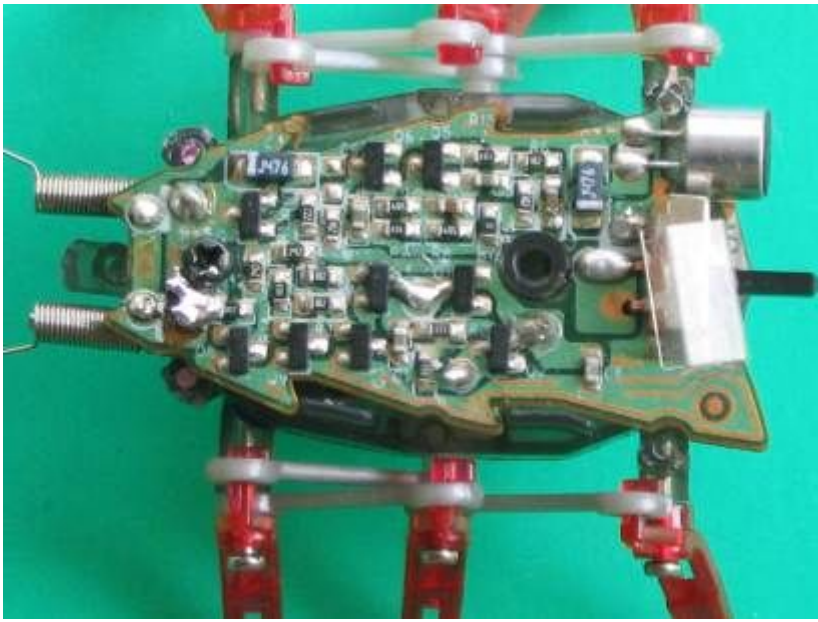

HEX BUG CIRCUIT

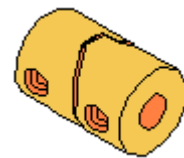
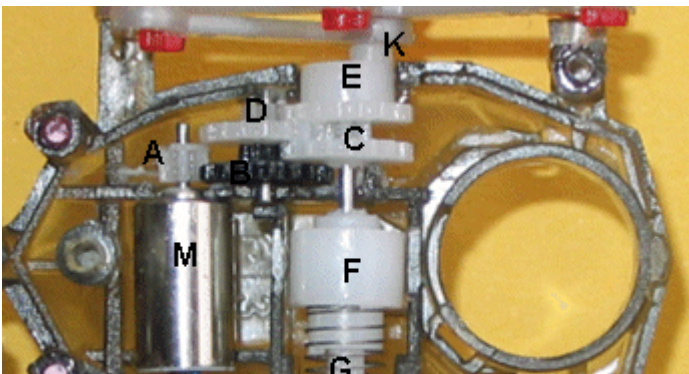

Inclined Dog Clutch

## HEX BUG GEARBOX

Hex Bug gearbox consists of a compound gearbox with output "K" (eccentric pin) driving the legs. You will need to see the project to understand how the legs operate.

When the motor is reversed, the clutch "F" is a housing that is spring-loaded to "H" and drives "H" via a square shaft "G". Gearwheel "C" is an idler and the centre of "F" is connected to "E" via the shaft. When "E" reverses, the centre of "F" consists of a driving inclined plane and pushes "F" towards "H" in a clicking motion. Thus only the right legs reverse and the bug makes a turn. When "E" is driven in the normal direction, the centre of "F" drives the outer casing "F" via an action called an "Inclined Dog Clutch" and "F" drives "G" via a square shaft and "G" drives "H" and "J" is an eccentric pin to drive the legs.

The drawing of an Inclined Dog Clutch shows how the clutch drives in only one direction. In the reverse direction it rides up on the ramp and "clicks" once per revolution. The spring "G" in the photo keeps the two halves together.

[to Index](#)

## PWM CONTROLLER

This 555 based PWM controller features almost 0% to 100% pulse width regulation using the 100k variable resistor, while keeping the oscillator frequency relatively stable. The frequency is dependent on the 100k pot and 100n to give a frequency range from about 170Hz to 200Hz.

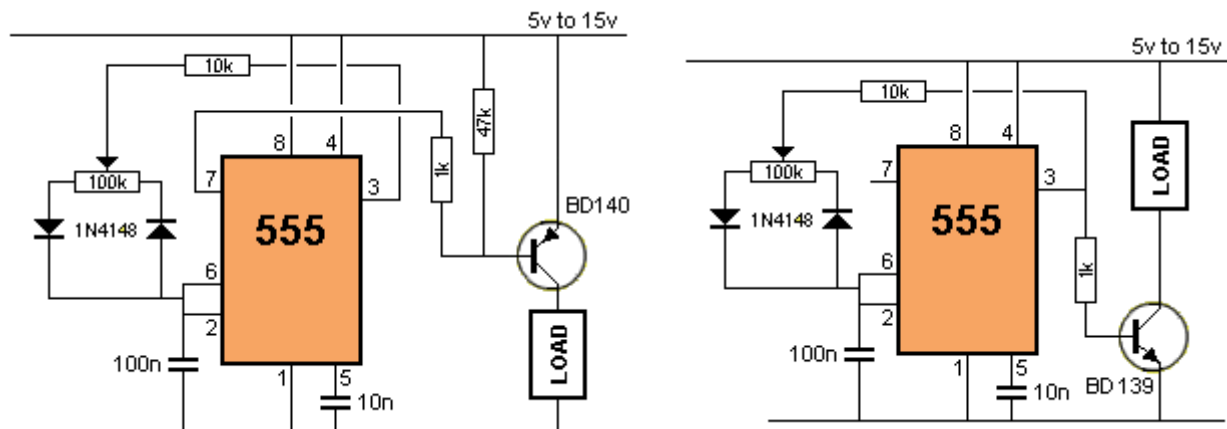

[to Index](#)

## LIMIT SWITCHES

This circuit detects when the water level is low and activates solenoid (or pump) 1 for 5 minutes (adjustable) to allow dirty water to be diverted, before filling the tank via solenoid 2.

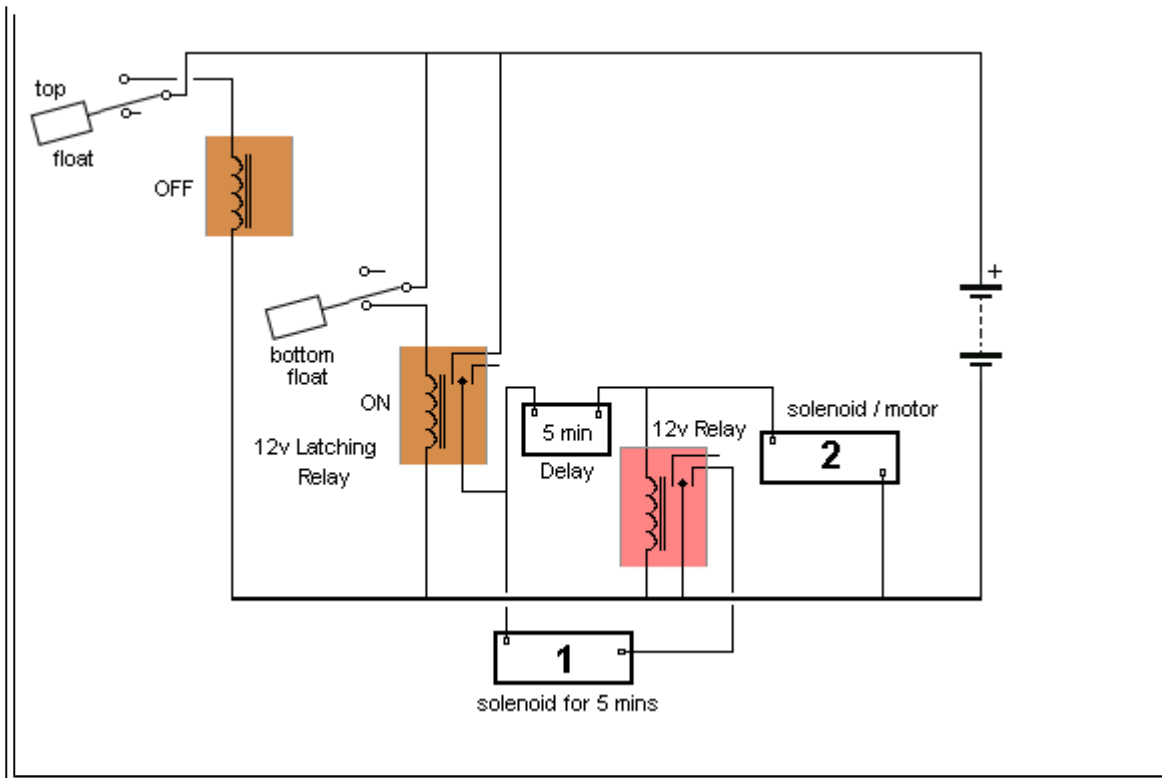

[to Index](#)

### WAILING SIREN

This circuit produces a penetrating (deafening) up/down siren sound.

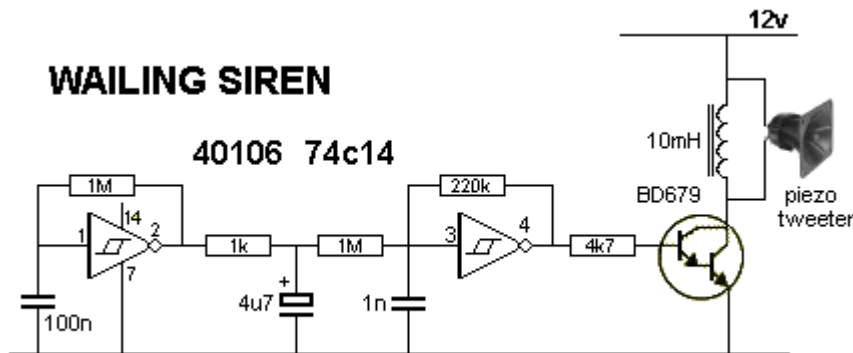

[to Index](#)

### MODEL RAILWAY TIME

Here is a simpler circuit than MAKE TIME FLY from our first book of 100 transistor circuits. For those who enjoy model railways, the ultimate is to have a fast clock to match the scale of the layout. This circuit will appear to "make time fly" by revolving the seconds hand once every 6 seconds. The timing can be adjusted by the electrolytics in the circuit. The electronics in the clock is disconnected from the coil and the circuit drives the coil directly. The circuit takes a lot more current than the original clock (1,000 times more) but this is the only way to do the job without a sophisticated chip.

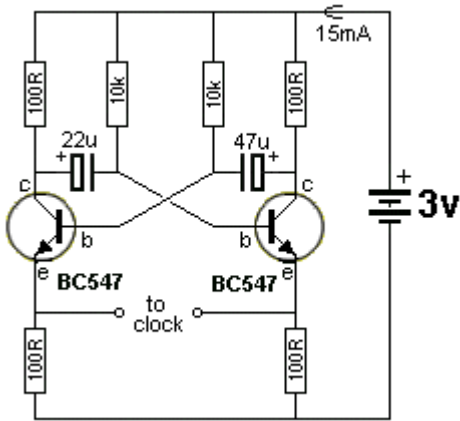

**Model Railway Time Circuit**

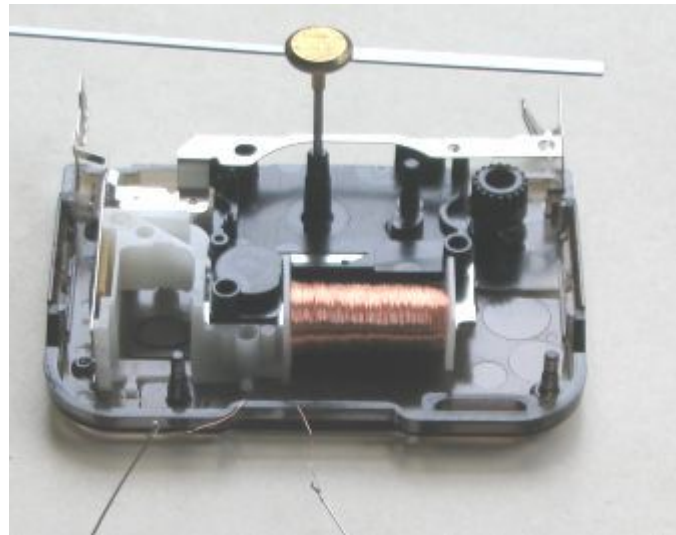

**Connecting the circuit to the clock coil**

For those who want the circuit to take less current, here is a version using a Hex Schmitt Trigger chip:

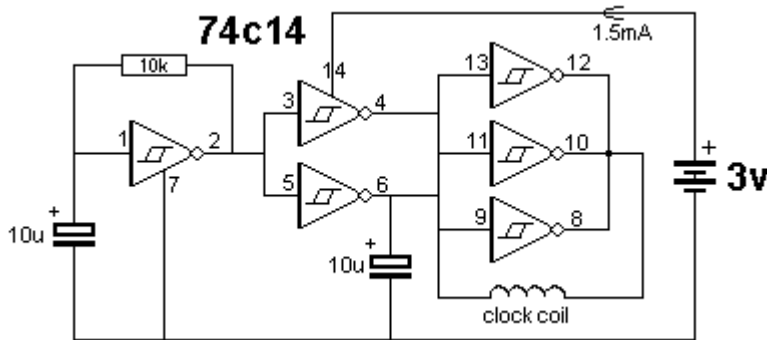

**Model Railway Time Circuit using a 74c14 Hex Schmitt Chip**

[to Index](#)

**SLOW START-STOP**

To make a motor start slowly and slow down slowly, this circuit can be used. The slide switch controls the action. The Darlington transistor will need a heatsink if the motor is loaded.

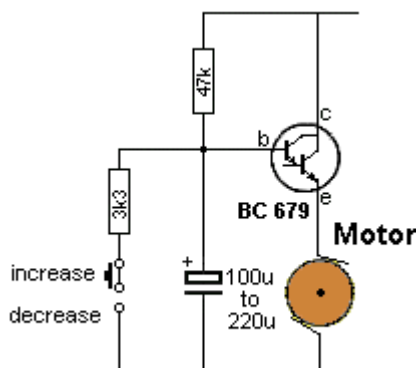

**Slow Start-Stop Circuit**

[to Index](#)

**VOLTAGE MULTIPLIERS**

The first circuit takes a square wave (any amplitude) and doubles it - minus about 2v

losses in the diodes and base-emitter of the transistors.

The second circuit must rise to at least 5.6v and fall to nearly 0.4v for the circuit to work. Also the rise and fall times must be very fast to prevent both transistors coming on at the same time and short-circuiting.

The third circuit doubles an AC voltage. The AC voltage rises "V" volts above the 0v rail and "V" volts below the 0v rail.

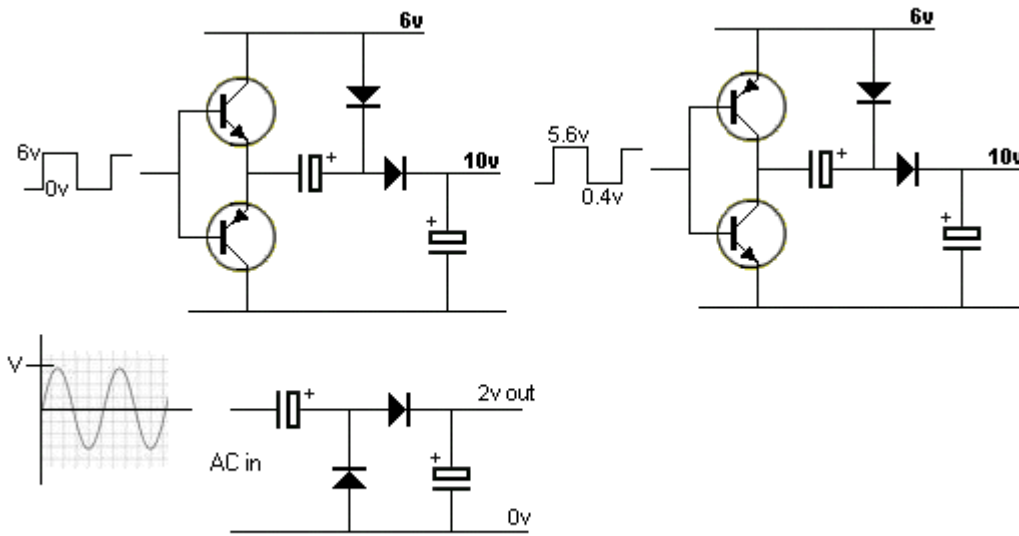

**VOLTAGE DOUBLER CIRCUITS**

[to Index](#)

**CLAP SWITCH**

This circuit toggles the LEDs each time it detects a clap or tap or short whistle.

The second 10u is charged via the 5k6 and 33k and when a sound is detected, the negative excursion of the waveform takes the positive end of the 10u towards the 0v rail. The negative end of the 10u will actually go below 0v and this will pull the two 1N4148 diodes so the anode ends will have near to zero volts on them.

As the voltage drops, the transistor in the bi-stable circuit that is turned on, will have 0.6v on the base while the transistor that is turned off, will have zero volts on the base.

As the anodes of the two signal diode are brought lower, the transistor that is turned on, will begin to turn off and the other transistor will begin to turn on via its 100u and 47k.

As it begins to turn on, the transistor that was originally turned on will get less "turn-on" from its 100u and 47k and thus the two switch over very quickly. The collector of the third transistor can be taken to a buffer transistor to operate a relay or other device.

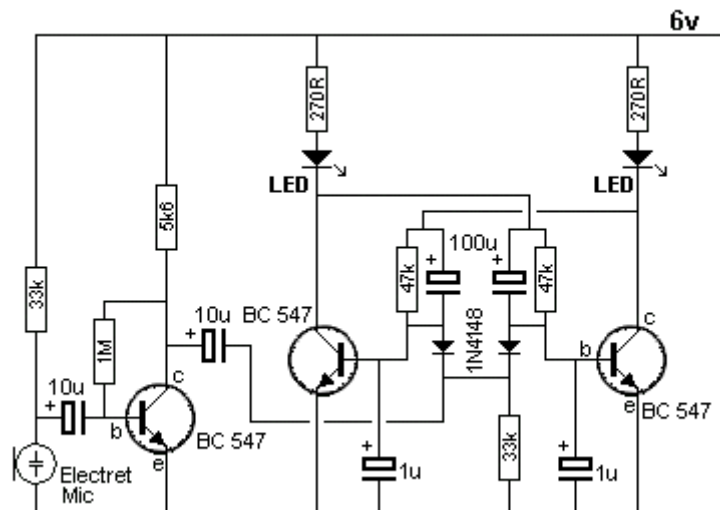

[to Index](#)

**INTERCOM**



Here is a 2-station intercom using common 8R mini speakers. The "press-to-talk" switches should have a spring-return so the intercom can never be left ON. The secret to preventing instability (motor-boating) with a high gain circuit like this is to power the speaker from a separate power supply! You can connect an extra station (or two extra stations) to this design.

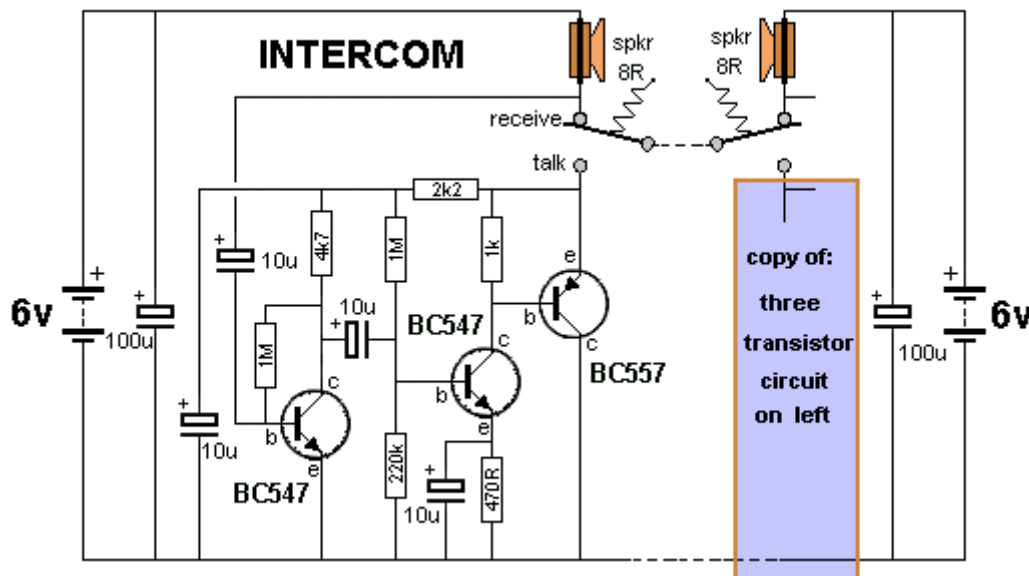

[to Index](#)

### WARNING BEACON

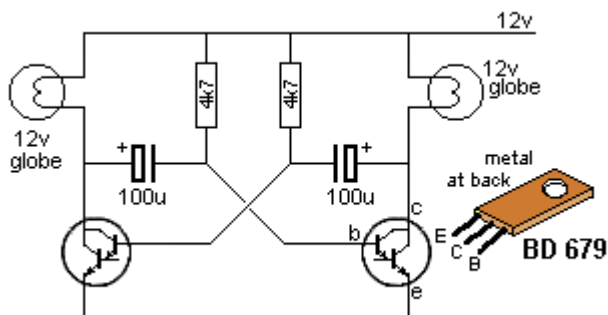

Here is a 12v Warning Beacon suitable for a car or truck break-down on the side of the road. The key to the operation of the circuit is the high gain of the Darlington transistors. The circuit must be kept "tight" (thick wires) to be sure it will oscillate.

A complete kits of parts and PC board costs \$5.00 plus postage from: Talking Electronics. Email [HERE](#) for details.

[to Index](#)

### PHASE-SHIFT OSCILLATOR also called SINEWAVE OSCILLATOR

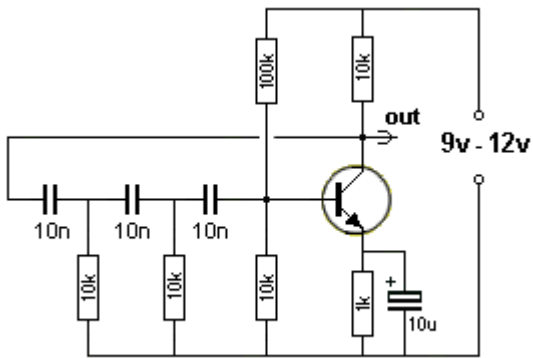

This circuit produces a sinewave very nearly equal to rail voltage. The important feature is the need for the emitter resistor and 10u bypass electrolytic. It is a most-important feature of the circuit. It provides reliable start-up and guaranteed operation. For 6v operation, the 100k is reduced to 47k. The three 10n capacitors and two 10k resistors (actually 3) determine the frequency of operation (700Hz). The 100k and 10k base-bias resistors can be replaced with 2M2 between base and collector. This type of circuit can be designed to operate from about 10Hz to about 200kHz.

[to Index](#)

### BLOCKING OSCILLATOR also called FLYBACK OSCILLATOR

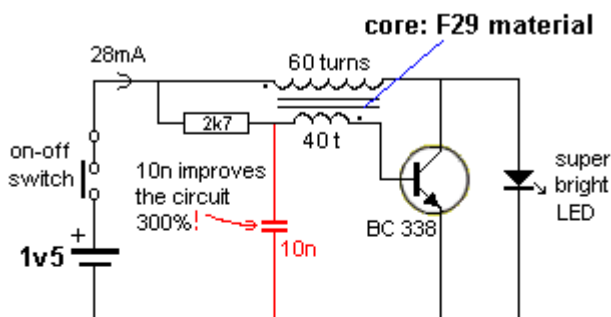

### LED TORCH CIRCUIT

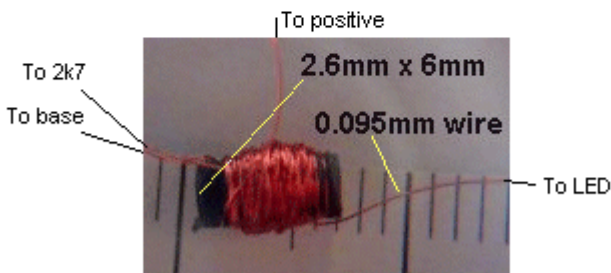

### Transformer Details

The circuit produces high voltage pulses (spikes) of about 40v p-p (when the LED is not connected), at a frequency of 200kHz. The super-bright LED on the output absorbs the pulses and uses the energy to produce illumination. The voltage across the LED will be about 3.6v. The winding to the base is connected so that it turns the transistor ON harder until it is saturated. At this point the flux cannot increase any more and the transistor starts to turn off. The collapsing magnetic field in the transformer produces a very high voltage and that's why we say the transformer operates in FLYBACK mode. This type of circuit will operate from 10kHz to a few MHz.

[to Index](#)

### LOW VOLTAGE FLASHER

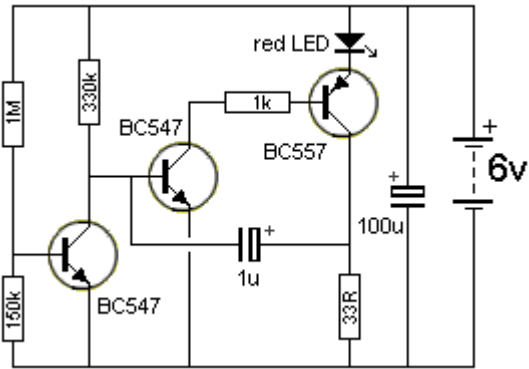

This circuit flashes when the voltage drops to 4v. The voltage "set-point" can be adjusted by changing the 150k on the base of the first transistor.

[to Index](#)

### POWER ON

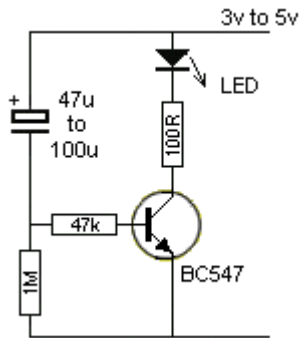

This LED illuminates for a few seconds when the power is turned on. The circuit relies on the 47µF discharging into the rest of the circuit so that it is uncharged when the circuit is turned on again.

[to Index](#)

### CAR LOOP DETECTOR

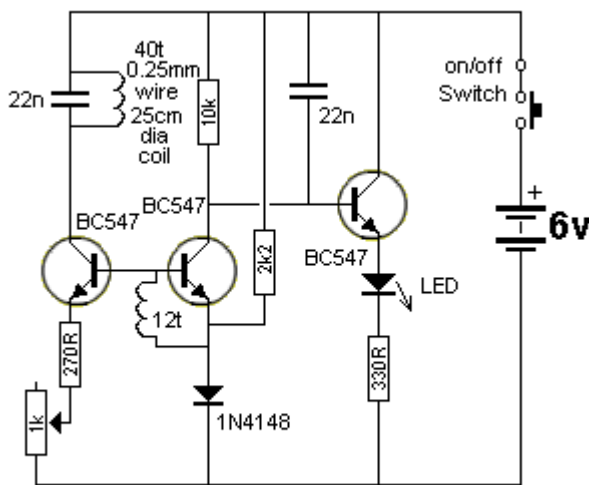

### VEHICLE DETECTOR

A 25cm dia coil (consisting of 40 turns and 12 turns) is placed in the centre of a driveway (between two sheets of plastic). When a vehicle is driven over the coil, it responds by the waveform collapsing. This occurs because the tank circuit made up of the 40 turns is receiving just enough

feedback signal from the 12 turns to keep it oscillating. When metal is placed near the coil, it absorbs some of the electromagnetic waves and the amplitude decreases. This reduces the amplitude in the 12 turns and the oscillations collapse. The second transistor turns off and the 10k pulls the base of the third transistor (an emitter-follower) to the 6v rail and turns on the LED.

[to Index](#)

### ALARM USING 4-BUTTONS

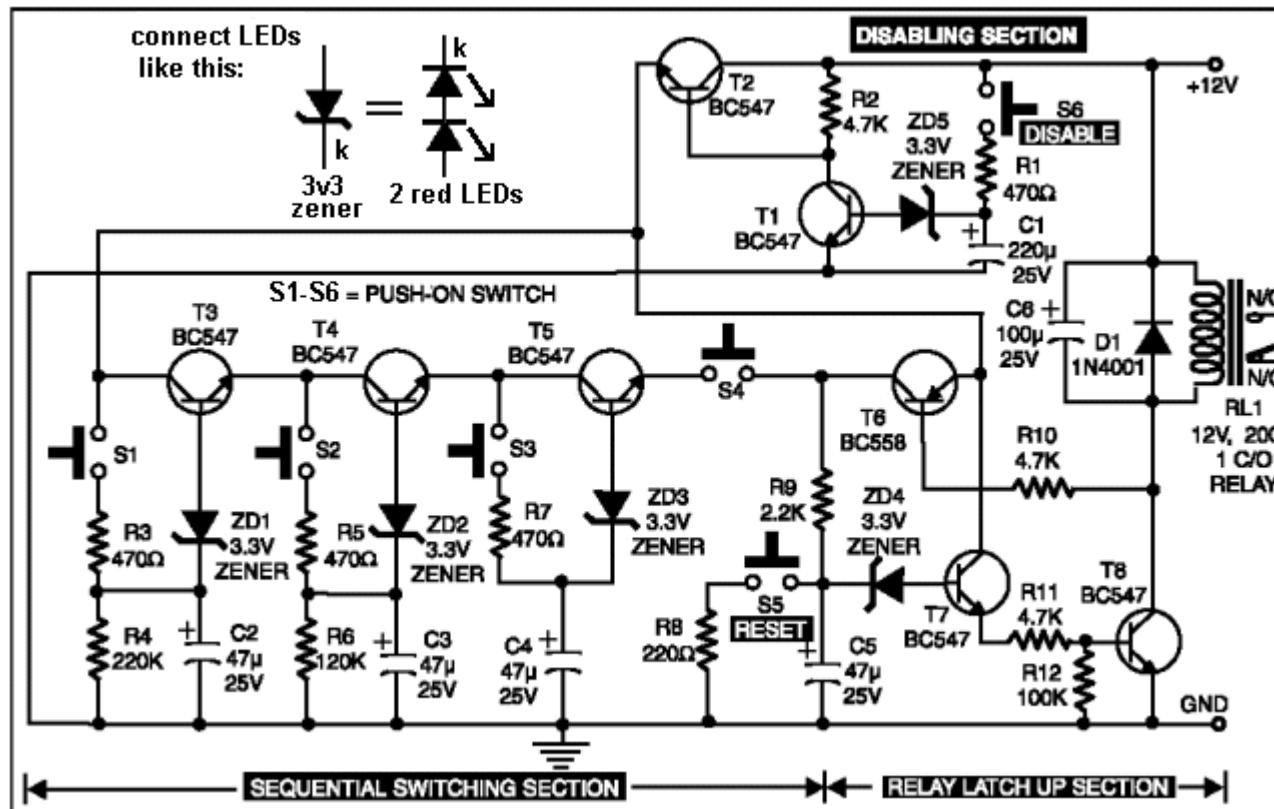

To open the lock, buttons S1, S2, S3, and S4 must be pressed in this order. They must be pressed for more than 0.7 seconds and less than 1.3 seconds.

Reset button S5 and disable button S6 are also included with the other buttons and if the disable button is pressed, the circuit will not accept any code for 60 seconds. Each of the 3V3 zeners can be replaced with two LEDs and this will show how you are progressing through the code. Make sure the LEDs are not visible to other users.

[to Index](#)

### AUDIO AMPLIFIER (mini)

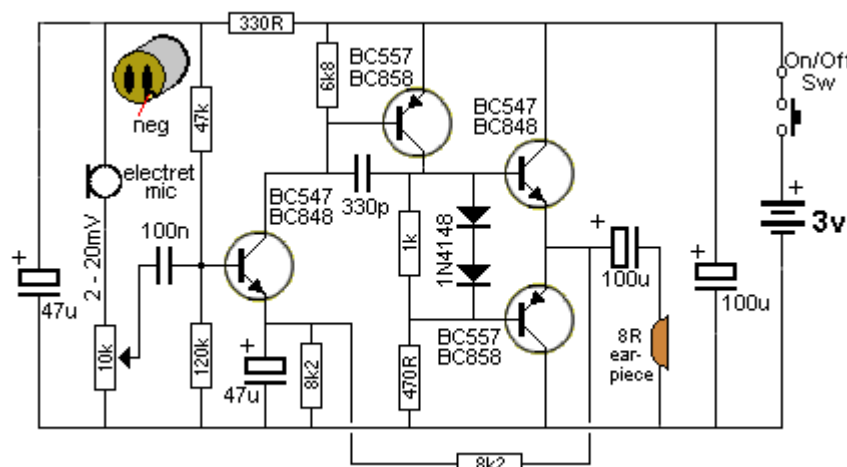

This project is called "mini" because its size is small and the output is small. It uses [surface mount](#) technology.

#### HOW THE CIRCUIT WORKS

The output is push-pull and consumes less than 3mA (with no signal) but drives the earpiece to a very loud when audio is detected.

The whole circuit is DC coupled so this makes it extremely difficult to set up.

Basically you don't know where to start with the biasing. The two most critical components are 8k2 between

the emitter of the first transistor and 0v rail and the 470R resistor.

The 8k2 across the 47u sets the emitter voltage on the BC 547 and this turns it on. The collector is directly connected to the base of a BC 557, called the driver transistor. Both these transistors are now turned on and output of the BC 557 causes current to flow through the 1k and 470R resistors so that the voltage developed across each resistor turns on the two output transistors. The end result is mid-rail voltage on the join of the two emitters.

The 8k2 feedback resistor provides major negative feedback while the 330p prevents high-frequency oscillation occurring.

[to Index](#)

### CAPACITOR DISCHARGE UNIT MkII (CDU2)

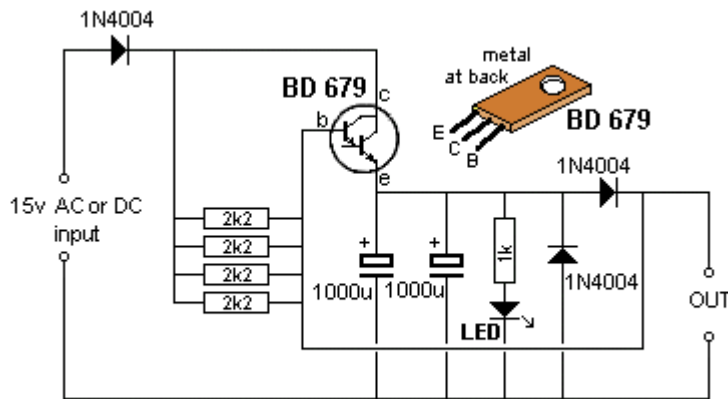

### CAPACITOR DISCHARGE UNIT MkII

This project is available as a kit for \$10.80 plus \$6.50 post. email [Talking Electronics](#) for details.

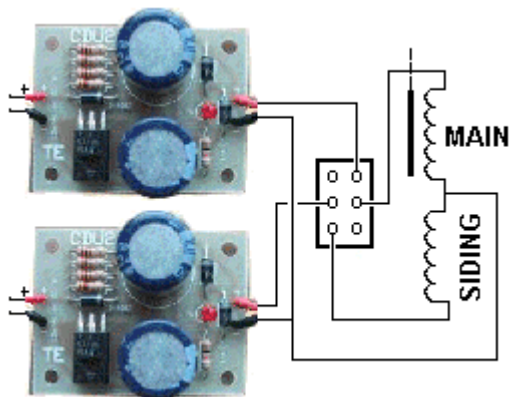
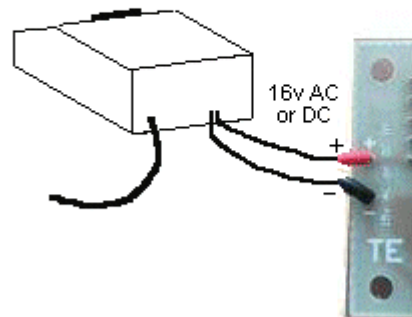

This circuit will operate a two-solenoid point-motor and prevent it overheating and causing any damage. The circuit produces energy to change the points and ceases to provide any more current. This is carried out by the switching arrangement within the circuit, by sampling the output voltage. If you want to control the points with a DPDT toggle switch or slide switch, you will need two CDU2 units.

#### HOW THE CIRCUIT WORKS

The circuit is supplied by 16v AC or DC and the diode on the input is used to rectify the voltage if AC is supplied. If nothing is connected to the output, the

base of the BD679 is pulled high and the emitter follows. This is called an emitter-follower stage. The two 1,000u electrolytics charge and the indicator LED turns on. The circuit is now ready. When the Main or Siding switch is pressed, the energy from the electrolytics is passed to the point motor and the points change. As the output voltage drops, the emitter-follower transistor is turned off and when the switch is released, the electrolytics start to charge again.

The point-motor can be operated via a Double-Pole Double-Throw Centre-Off toggle switch, providing the switch is returned to the centre position after a few seconds so that the CDU unit can charge-up.

[to Index](#)

### PHONE BUG

This circuit connects to a normal phone line and when the voltage drops to less than 15v, the first transistor is turned off and enables the second transistor to oscillate at approx 100MHz and transmit the phone conversation to a nearby FM radio.

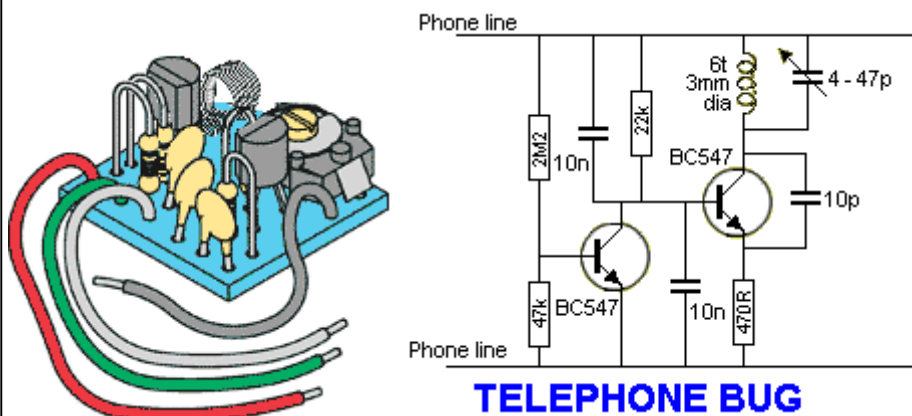

[to Index](#)

### CODE LOCK

This circuit turns on a relay when the correct code is entered on the 8-way DIP switches. Two different types of DIP switches are shown. Keep the top switch off and no current will be drawn by the circuit. There are 256 different combinations and because the combination is in binary, it would be very difficult for a burglar to keep up with the settings of the switches.

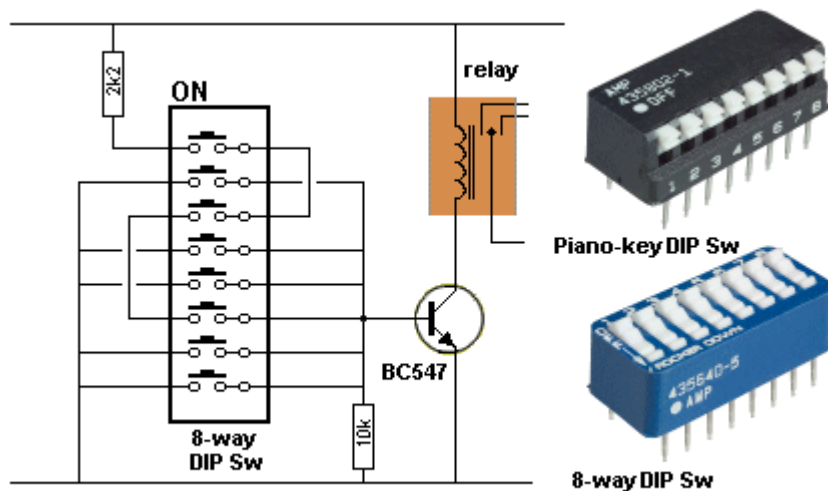

[to Index](#)

## Circuit Symbols

The list below covers almost every symbol you will find on an electronic circuit diagram. It allows you to identify a symbol and also draw circuits. It is a handy reference and has some symbols that have never had a symbol before, such as a Flashing LED and electroluminescence panel.

Once you have identified a symbol on a diagram you will need to refer to specification sheets to identify each lead on the actual component.

The symbol does not identify the actual pins on the device. It only shows the component in the circuit and how it is wired to the other components, such as input line, output, drive lines etc. You cannot relate the shape or size of the symbol with the component you have in your hand or on the circuit-board.

Sometimes a component is drawn with each pin in the same place as on the chip etc. But this is rarely the case.

Most often there is no relationship between the position of the lines on the circuit and the pins on the component.

That's what makes reading a circuit so complex.













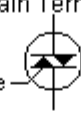











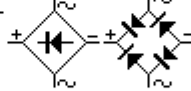









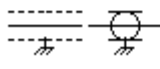



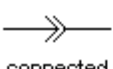









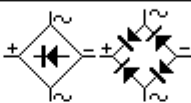





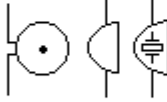

This is very important to remember with transistors, voltage regulators, chips and so many other components as the position of the pins on the symbol are not in the same places as the pins or leads on the component and sometimes the pins have different functions according to the manufacturer. Sometimes the pin numbering is different according to the component, such as positive and negative regulators.

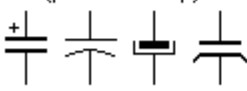
You must to refer to the manufacturer's specification sheet to identify each pin, to be sure you have identified them correctly.











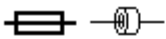
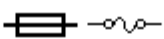

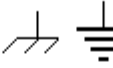

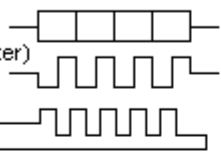
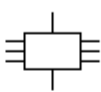
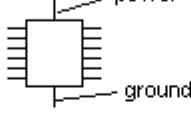





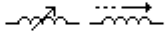









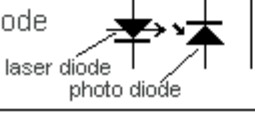

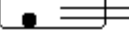













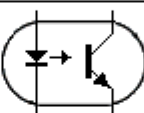
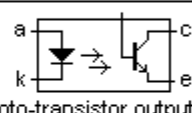
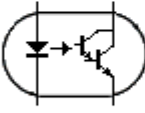
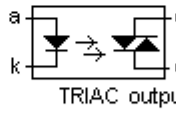

Colin Mitchell

## CIRCUIT SYMBOLS

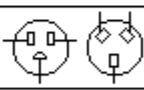









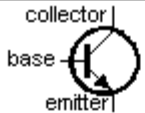





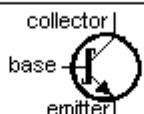

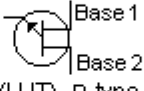
Some additional symbols have been added to the following list. See Circuit Symbols on the index of [Talking Electronics.com](http://TalkingElectronics.com)

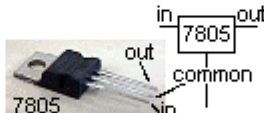
<h1 style="margin: 0;">CIRCUIT SYMBOLS</h1> <span style="color: red; font-weight: bold;">by TALKING ELECTRONICS</span>				
AC current:  voltage: 	ALTERNISTOR TRIAC A TRIAC and 33 - 43v DIAC 	Main Terminal 1 Gate Main Terminal 2	Ammeter (amp meter) 	
AND Gate 	AND Gate 	Antenna Loop, Shielded 	Antenna Loop, Unshielded 	Antenna balanced 
Antenna unbalanced 	Attenuator, fixed (see Resistor) 	Attenuator, variable (see Resistor) 	Battery 	
Bilateral Switch (DIAC) 	Bridge Rectifier (Diode Bridge) 	BUFFER (Amplifier Gate) 		
BUFFER (Amplifier Gate) 	Buzzer 	Capacitor feedthrough 		
Capacitor non-polarised 	Capacitor polarised (see electrolytic) 	Capacitor Variable 		
Cavity Resonator 	Cell 	Circuit Breaker 		
Coaxial Cable 	CRO - Cathode Ray Oscilloscope 	Crystal Microphone (Piezoelectric) 		
Connectors Plug (male)  Jack (female)  connected  Plug (male)  (female) 	Crystal Piezoelectric  Darlington Transistor 	DC current:  voltage: 		
Diode - Gunn 	Diode - Light Emitting (LED) 	Delay Line 		
Diode Photovoltaic 	Diode Bridge (Bridge Rectifier) 	Diode 		
Diode - Varactor 	Diode - Zener 	Diode Photo Sensitive 		
Diode - Pin 	Earth Ground 			
Earpiece (earphone, crystal earpiece) 	Electroluminescence 	Electret Microphone (Condenser mic) 		
Electrolytic (Polarised Capacitor)  alternate symbols: (positive on top) 	Electrolytic - Tanatalum positive end black band or chamfer  	Exclusive-OR Gate (XOR Gate) 		
Field Effect Transistor (FFT) n-channel 	Field Effect Transistor (FFT) n-channel 	Exclusive-OR Gate (XOR Gate) 		
Flashing LED (Light Emitting Diode) 				

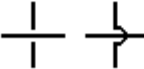

Ferrite Bead 	Fuse 	Galvanometer 
Globe 	Ground Chassis 	Ground Earth 
Heater (immersion heater) (cooker etc) 	IC Integrated Circuit  	Inductor Air Core 
Headphone 	Inductor Tapped 	Inductor Iron Core or ferrite core 
Inverter (NOT Gate) 	Inductor Variable 	Integrated Circuit 
Jack Co-axial 	INVERTER (NOT Gate) 	Jack Phone (Switched) 
Jack Phone (3 conductor) 	Jack Phone (Phone Jack) 	Lamp Incandescent 
Lamp - Neon 	Key Telegraph (Morse Key) 	LDR (Light Dependent Resistor) 
LASER diode 	LASCR (Light Activated Silicon Controlled Rectifier) 	Light Emitting Diode (LED) 
Mercury Switch 	Light Emitting Diode (LED - flashing)  (Indicates chip inside LED)	Microphone (see Electret Mic) 
Microphone (Crystal - piezoelectric) 	Micro-amp meter (micro-ammeter) 	Motor 
NAND Gate 	Milliamp meter (milli-ammeter) 	Nitinol wire "Muscle wire" 
Negative Voltage Connection 	NOR Gate 	NOR Gate 
NOT Gate Inverter 	NOT Gate Inverter 	Ohm meter 
Operational Amplifier (Op Amp) 	Optocoupler (Transistor output) 	Opto Coupler (Opto-isolator) 
Optocoupler (Darlington output) 	Opto Coupler (Opto-isolator) TRIAC output 	OR Gate 
OR Gate 	Oscilloscope see CRO 	Outlet (Power Outlet) 
Piezo Diaphragm 	Photo Cell (photo sensitive resistor) 	Photo Diode 
Photo Darlington Transistor 	Photo FET (Field Effect Transistor) 	Photo Transistor 

Photovoltaic Cell (Solar Cell)		Piezo Tweeter (Piezo Speaker)		Positive Voltage Connection	
Potentiometer (variable resistor)		Programmable Unijunction Transistor PUT		Rectifier Silicon Controlled (SCR)	
Rectifier Semiconductor		Reed Switch		Relay - spst	
Relay - spdt		Relay - dpst		Relay - dpdt	
Resistor Fixed		Resistor Non Inductive		Resistor preset	
Resistor variable		Resonator 3-pin		RFC Radio Frequency Choke	
Rheostat (Variable Resistor)		Saturable Reactor		Schmitt Trigger (Inverter Gate)	
Schottky Diode (also Shottky) Low forward voltage 0.3v Fast switching also called Schottky Barrier Diode		Shielding		Shockley Diode 4-layer PNP device Remains off until forward current reaches the forward break-over voltage.	
Silicon Bilateral Switch (SBS)		Signal Generator		Silicon Controlled Rectifier (SCR)	
Surface Mount		Silicon Unilateral Switch (SUS)		Solar Cell	
Switch - spst		Switch - process activated normally open: normally closed:		Switch - push (Push Button)	
Switch - spdt		Flow		Test Point	
Switch - dpst		Level		Thermal Probe NTC: as temp rises, resistance decreases	
Switch - dpdt		Pressure		Thyristors: Main Terminal 1	
Switch - mercury tilt switch		Temperature		Bilateral Switch	
Spark Gap		Speaker		Anode Cathode	
Switch - push off (used in alarms etc)		Switch - Rotary		MT2	
Thermal Probe		Thermocouple		Cathode	
Transformer Air Core		Tilt switch mercury		DIAC	
Transformer Iron Core		Touch Sensor		SCR	
Transformer (Tapped Primary/Sec)		Transformer		TRIAC	

Transistor Bipolar - NPN 	Transistor Bipolar - PNP 	Transistor n-channel Field Effect 
Transistor p-channel Field Effect 	Transistor Metal Oxide Single Gate 	Transistor Metal Oxide Dual Gate 
Transistor Photosensitive 	Transistor Schottky - NPN 	Transistor Unijunction - UJT N-type 
TRIAC 	Transistor Unijunction - UJT P-type 	Tunnel Diode 
Varactor varactor diode 	Voltage Regulator (7805 etc) 	Voltmeter 
Wattmeter 	Wires 	Wires Connected 
Wires Not Connected 	XOR Gate (exclusive OR) 	XOR Gate (exclusive OR) 
Zener Diode 	Learn <b>BASIC ELECTRONICS</b> Go to: <a href="http://www.talkingelectronics.com">http://www.talkingelectronics.com</a>	

[to Index](#)

## IC PINOUTS

The following list covers just a few of the IC's on the market and these are the "simple" or "basic" or "digital" IC's suitable for experimenting.

When designing a circuit around an IC, you have to remember two things:

1. Is the IC still available? and
2. Can the circuit be designed around a microcontroller?

Sometimes a circuit using say 3 or 4 IC's can be re-designed around an 8-pin or 16-pin microcontroller and it can be kept from prying eyes due to a feature called "code protection." A microcontroller project is more up to date, cheaper and can be re-programmed to alter the features.

This will be covered in the next eBook. It is worth remembering - as it is the way of the future.

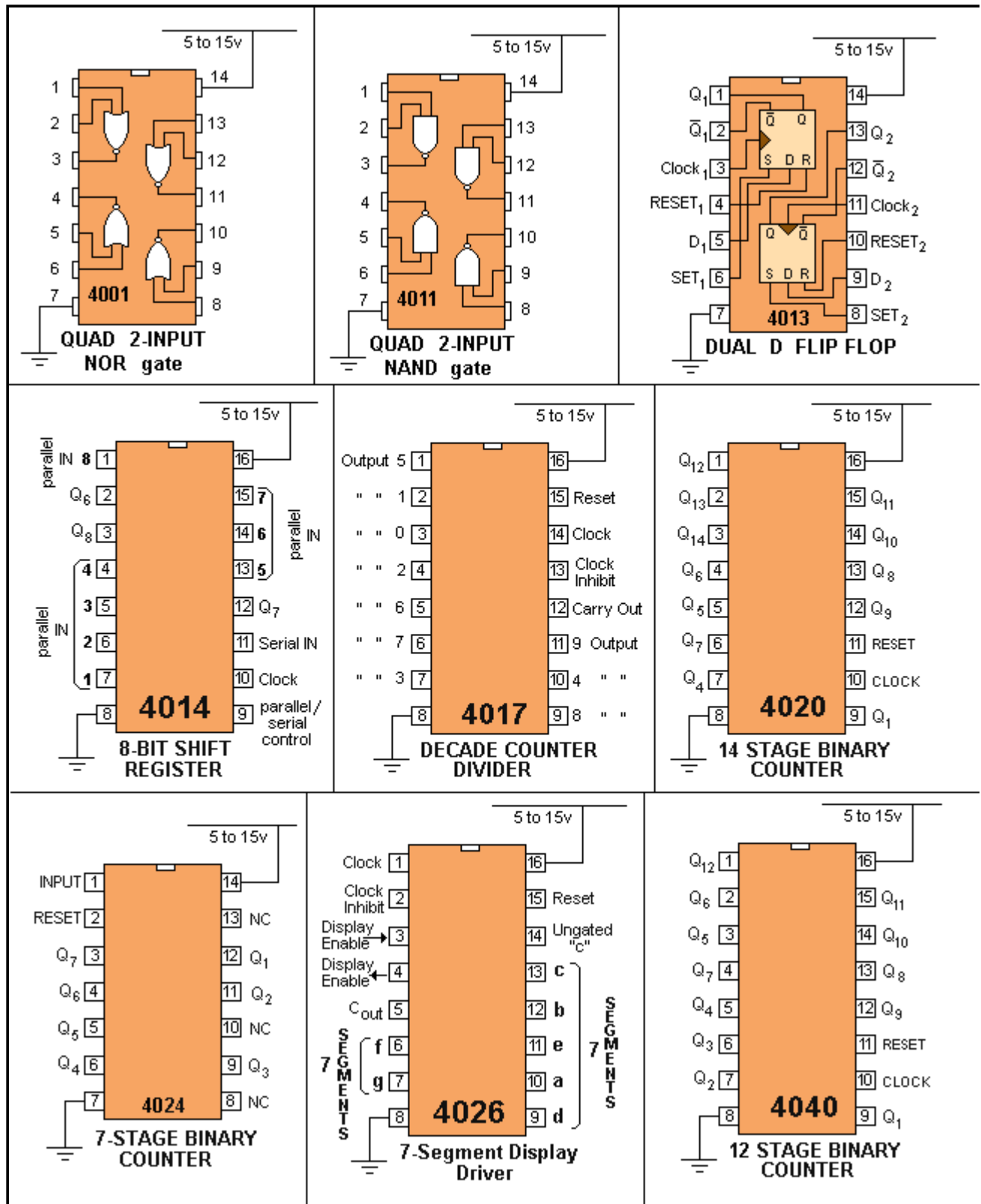

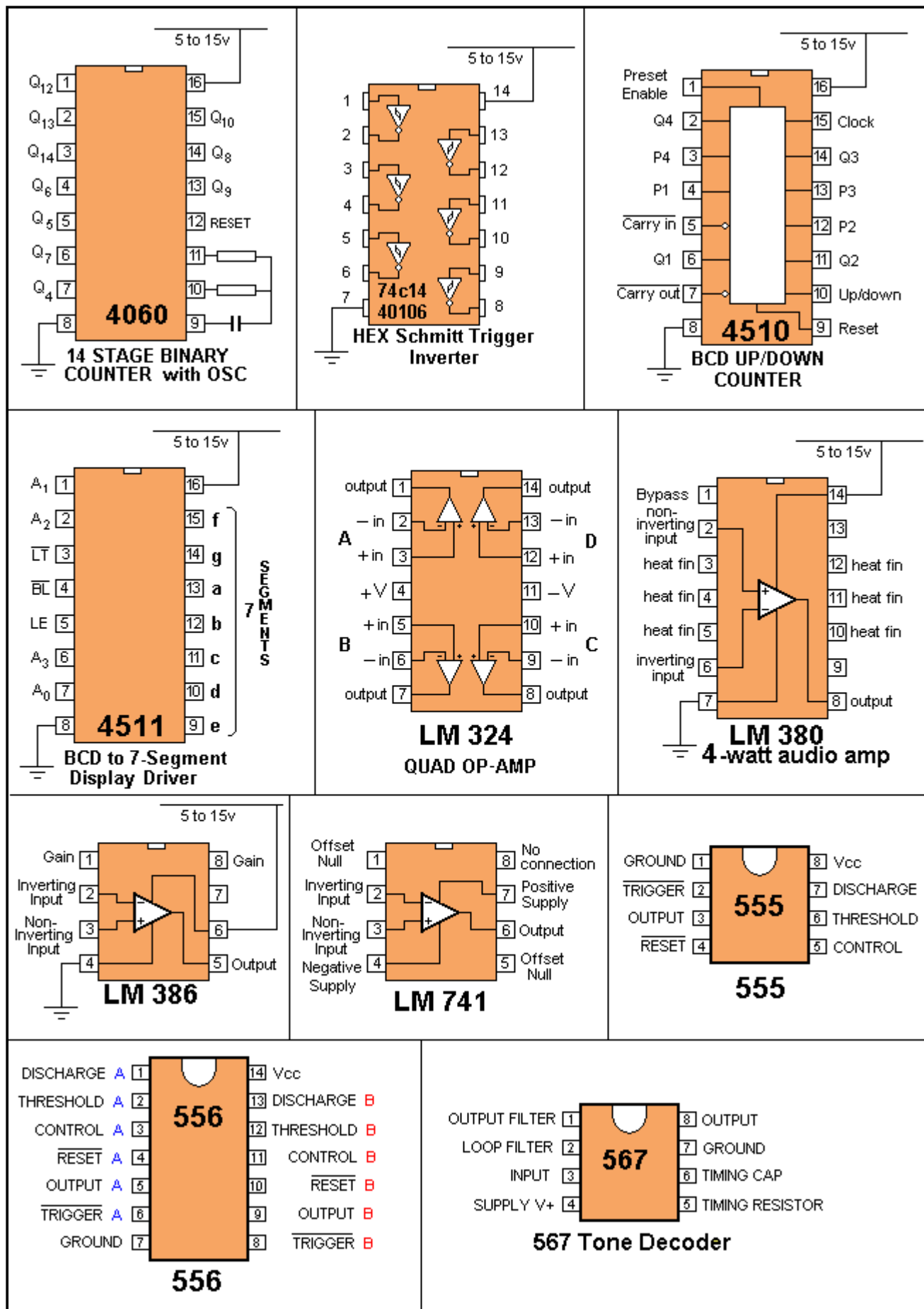













































































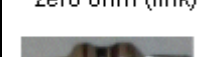









[to Index](#)

**All the resistor colours:**

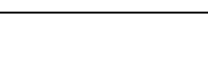
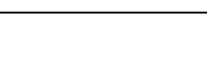
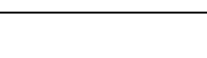
This is called the "normal" or "3 colour-band" (5%) range. If you want the 4 colour-band (1%) series, refer to

Talking Electronics website and click: **Resistors 1%** on the left index. Or you can use the table below.

 1R0	 10R	 100R	 1k0
 1R2	 12R	 120R	 1k2
 1R5	 15R	 150R	 1k5
 1R8	 18R	 180R	 1k8
 2R2	 22R	 220R	 2k2
 2R7	 27R	 270R	 2k7
 3R3	 33R	 330R	 3k3
 3R9	 39R	 390R	 3k9
 4R7	 47R	 470R	 4k7
 5R6	 56R	 560R	 5k6
 6R8	 68R	 680R	 6k8
 8R2	 82R	 820R	 8k2
 10k	 100k	 1M0	 10M
 12k	 120k	 1M2	 22M
 15k	 150k	 1M5	
 18k	 180k	 1M8	 0R1
 22k	 220k	 2M2	 R22
 27k	 270k	 2M7	 0R0
 33k	 330k	 3M3	zero ohm (link)
 39k	 390k	 3M9	
 47k	 470k	 4M7	$\frac{1}{10}$ th watt and 0.25 watt
 56k	 560k	 5M6	
 68k	 680k	 6M8	
 82k	 820k	 8M2	

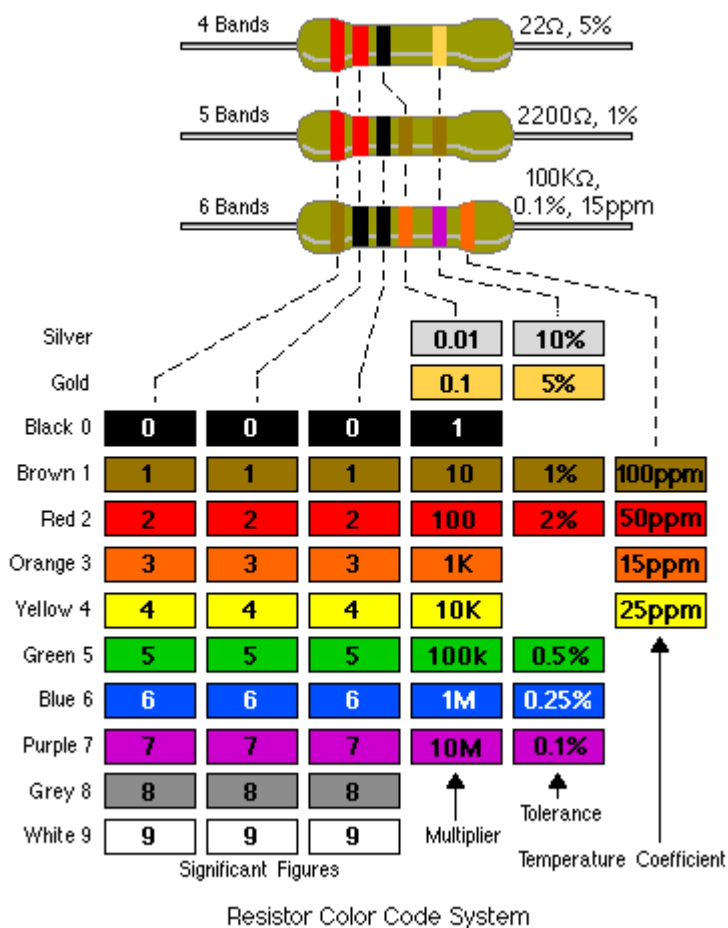

[to Index](#)

**MAKE ANY RESISTOR VALUE:**

If you don't have the exact resistor value for a project, don't worry. Most circuits will work with a value slightly higher or lower.

But if you want a particular value and it is not available, here is a chart.

Use 2 resistors in series or parallel as shown:

Required Value	R1	Series/Parallel	R2	Actual value:
10	4R7	S	4R7	9R4
12	10	S	2R2	12R2
15	22	P	47	14R9
18	22	P	100	18R
22	10	S	12	22
27	22	S	4R7	26R7
33	22	S	10	32R
39	220	P	47	38R7
47	22	S	27	49
56	47	S	10	57
68	33	S	33	66
82	27	S	56	83

There are other ways to combine 2 resistors in parallel or series to get a particular value. The examples above are just one way.

4R7 = 4.7 ohms