

### Features

- -20V/-4A,  
 $R_{DS(ON)} = 40m\Omega$  (Typ.) @  $V_{GS} = -4.5V$   
 $R_{DS(ON)} = 55m\Omega$  (Typ.) @  $V_{GS} = -2.5V$
- Low  $R_{DS(ON)}$
- Super High Dense Cell Design
- Reliable and Rugged
- Lead Free and Green Available

### Applications

- Power Management
- Load Switch

### Absolute Maximum Ratings

### Pin Description

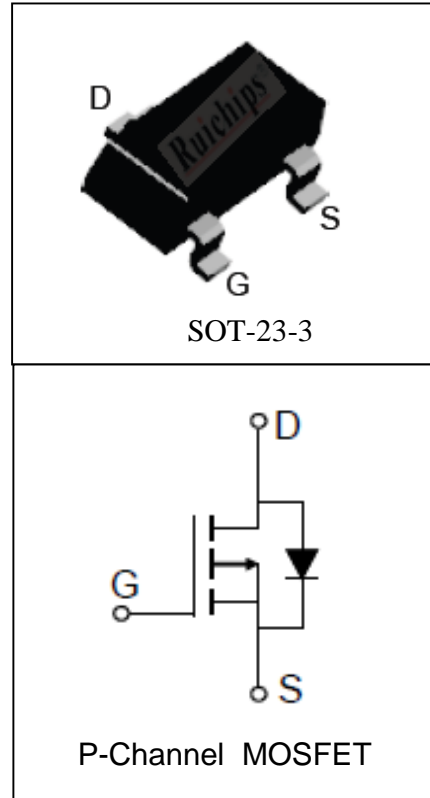

Symbol	Parameter	Rating	Unit
<b>Common Ratings</b> ( $T_A = 25^\circ C$ Unless Otherwise Noted)			
$V_{DSS}$	Drain-Source Voltage	-20	V
$V_{GSS}$	Gate-Source Voltage	$\pm 12$	
$T_J$	Maximum Junction Temperature	150	$^\circ C$
$T_{STG}$	Storage Temperature Range	-55 to 150	$^\circ C$
$I_S$	Diode Continuous Forward Current	$T_A = 25^\circ C$ -1.5	A
<b>Mounted on Large Heat Sink</b>			
$I_{DP}$	300 $\mu s$ Pulse Drain Current Tested	$T_A = 25^\circ C$ -16 <sup>①</sup>	A
$I_D$	Continuous Drain Current	$T_A = 25^\circ C$ -4	A
		$T_A = 70^\circ C$ -3.2	
$P_D$	Maximum Power Dissipation	$T_A = 25^\circ C$ 1.3	W
		$T_A = 70^\circ C$ 0.8	
$R_{\theta JA}$ <sup>②</sup>	Thermal Resistance-Junction to Ambient	100	$^\circ C/W$

**Electrical Characteristics** ( $T_A=25^\circ\text{C}$  Unless Otherwise Noted)

Symbol	Parameter	Test Condition	RU20P4C			Unit
			Min.	Typ.	Max.	
<b>Static Characteristics</b>						
$BV_{DSS}$	Drain-Source Breakdown Voltage	$V_{GS}=0V, I_{DS}=-250\mu A$	-20			V
$I_{DSS}$	Zero Gate Voltage Drain Current	$V_{DS}=-20V, V_{GS}=0V$ $T_J=85^\circ\text{C}$			-1	$\mu A$
$V_{GS(th)}$	Gate Threshold Voltage	$V_{DS}=V_{GS}, I_{DS}=-250\mu A$	-0.4	-0.7	-1.1	V
$I_{GSS}$	Gate Leakage Current	$V_{GS}=\pm 10V, V_{DS}=0V$			$\pm 100$	nA
$R_{DS(ON)}^{(3)}$	Drain-Source On-state Resistance	$V_{GS}=-4.5V, I_{DS}=-4A$		40	60	$m\Omega$
		$V_{GS}=-2.5V, I_{DS}=-3A$		55	100	$m\Omega$
<b>Diode Characteristics</b>						
$V_{SD}^{(3)}$	Diode Forward Voltage	$I_{SD}=-1A, V_{GS}=0V$			-1	V
$t_{rr}$	Reverse Recovery Time	$I_{SD}=-4A, di_{SD}/dt=100A/\mu s$		15		ns
$Q_{rr}$	Reverse Recovery Charge			8		nC
<b>Dynamic Characteristics</b> <sup>(4)</sup>						
$R_G$	Gate Resistance	$V_{GS}=0V, V_{DS}=0V, F=1\text{MHz}$		7.5		$\Omega$
$C_{iss}$	Input Capacitance	$V_{GS}=0V,$ $V_{DS}=-10V,$ Frequency=1.0MHz		585		pF
$C_{oss}$	Output Capacitance			95		
$C_{rss}$	Reverse Transfer Capacitance			50		
$t_{d(ON)}$	Turn-on Delay Time		$V_{DD}=-10V, R_L=2.5\Omega,$ $I_{DS}=-4A, V_{GEN}=-4.5V,$ $R_G=6\Omega$		8	
$t_r$	Turn-on Rise Time			11		
$t_{d(OFF)}$	Turn-off Delay Time			30		
$t_f$	Turn-off Fall Time			10		
<b>Gate Charge Characteristics</b> <sup>(4)</sup>						
$Q_g$	Total Gate Charge	$V_{DS}=-16V, V_{GS}=-4.5V,$ $I_{DS}=-4A$		9	13	nC
$Q_{gs}$	Gate-Source Charge			1.8		
$Q_{gd}$	Gate-Drain Charge			2.9		

- Notes: ① Pulse width limited by safe operating area.  
 ② When mounted on 1 inch square copper board,  $t \leq 10\text{sec}$ . The value in any given application depends on the user's specific board design.  
 ③ Pulse test ; Pulse width  $\leq 300\mu s$ , duty cycle  $\leq 2\%$ .  
 ④ Guaranteed by design, not subject to production testing.

**Typical Characteristics**

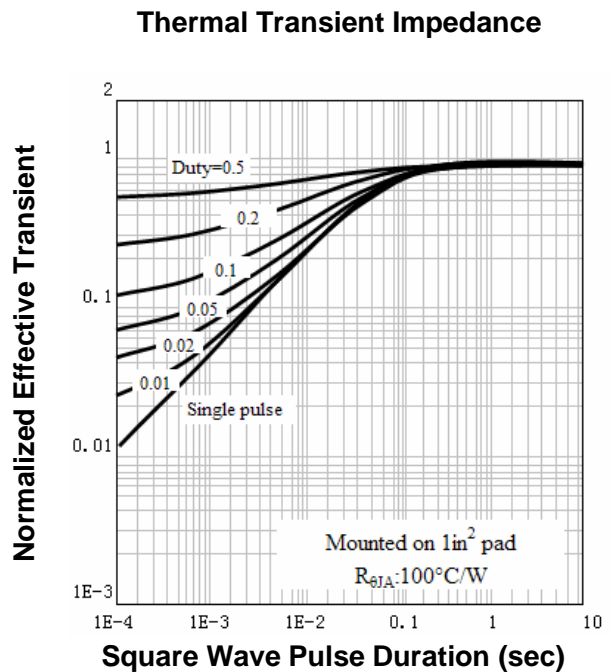
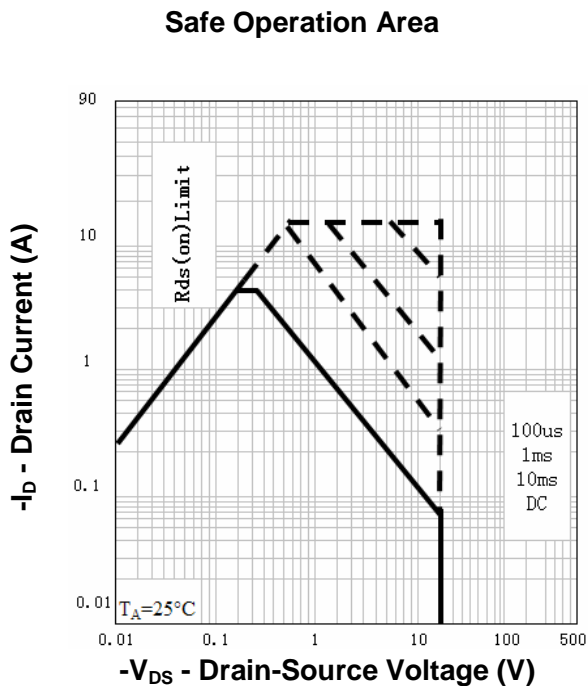
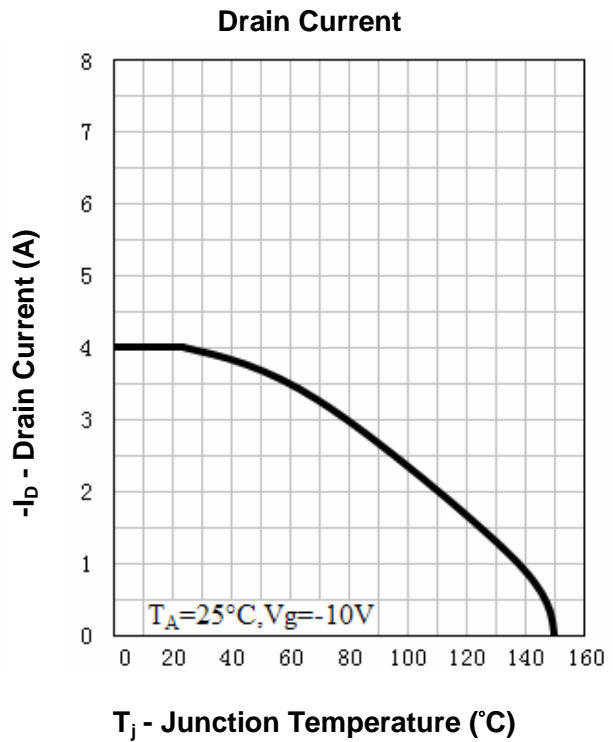
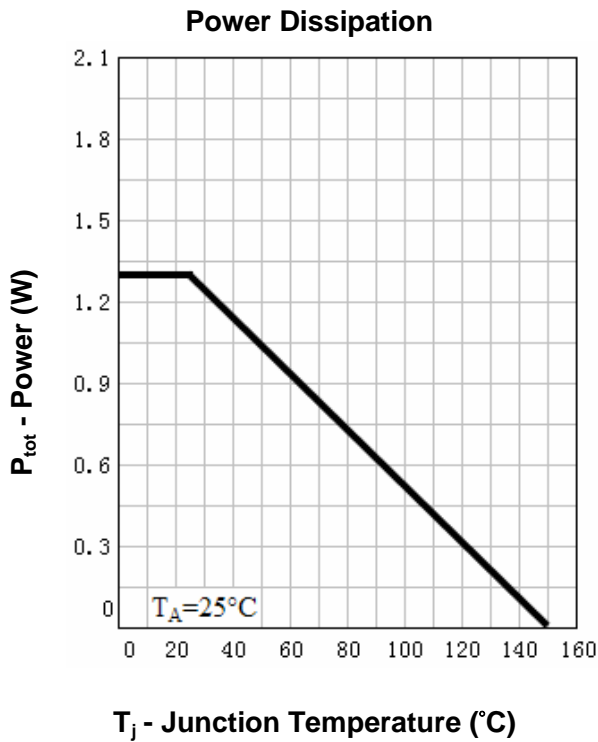

**Typical Characteristics**

**Output Characteristics**

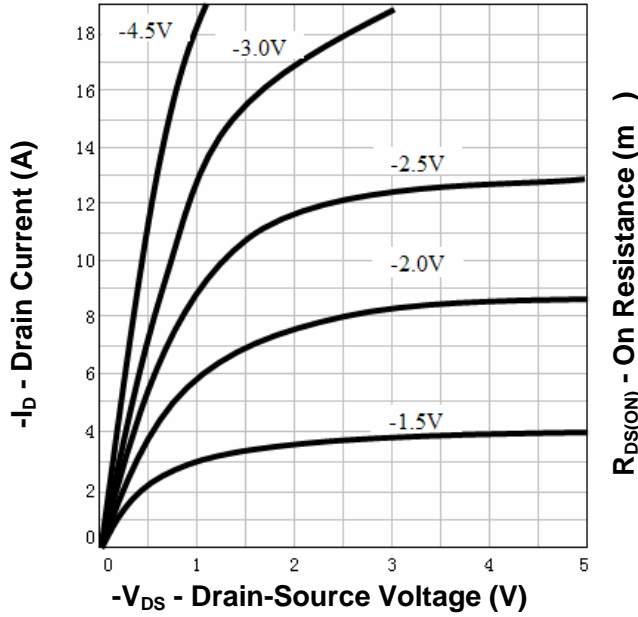

**Drain-Source On Resistance**

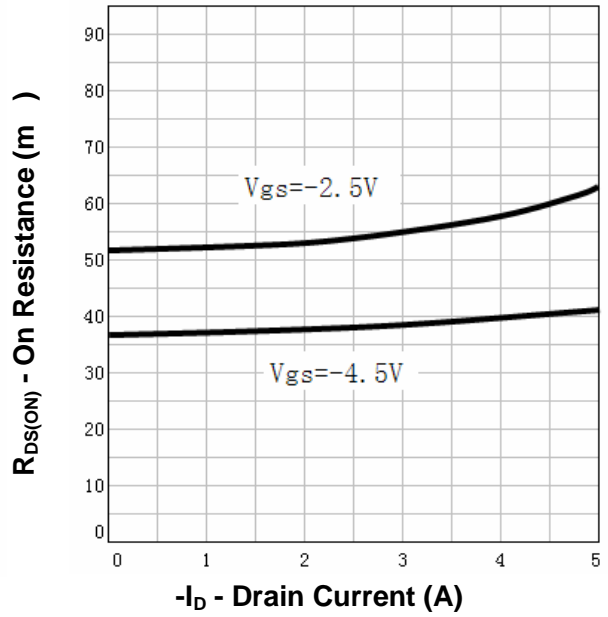

**Drain-Source On Resistance**

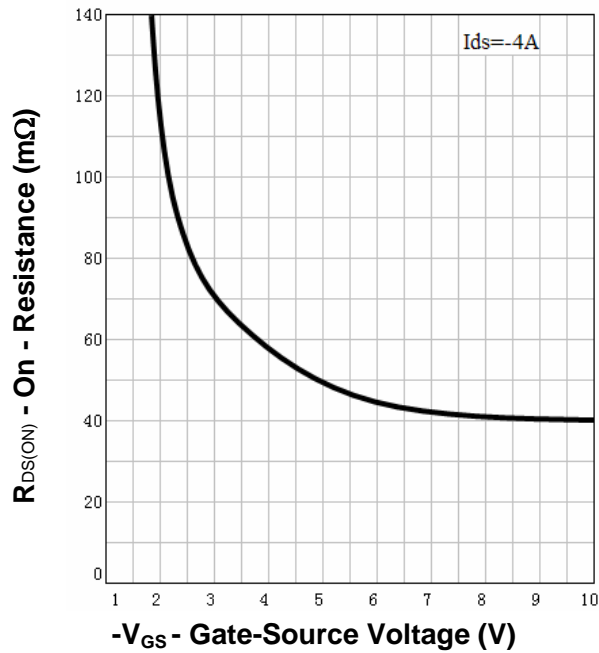

**Gate Threshold Voltage**

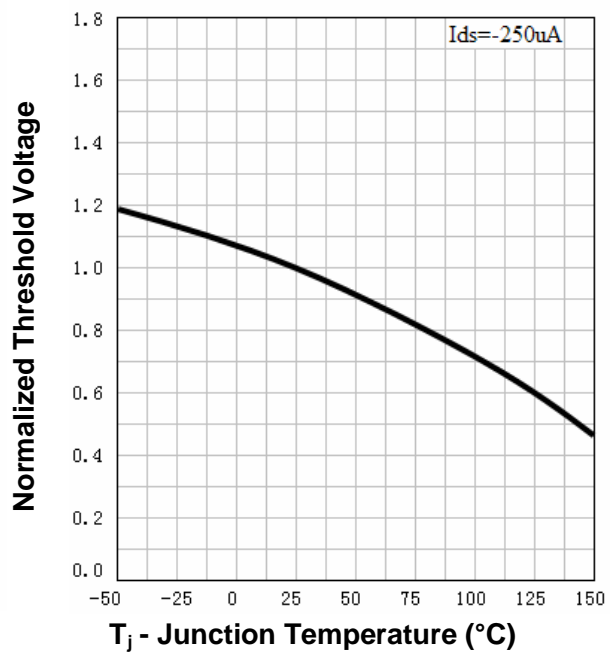

**Typical Characteristics**

**Drain-Source On Resistance**

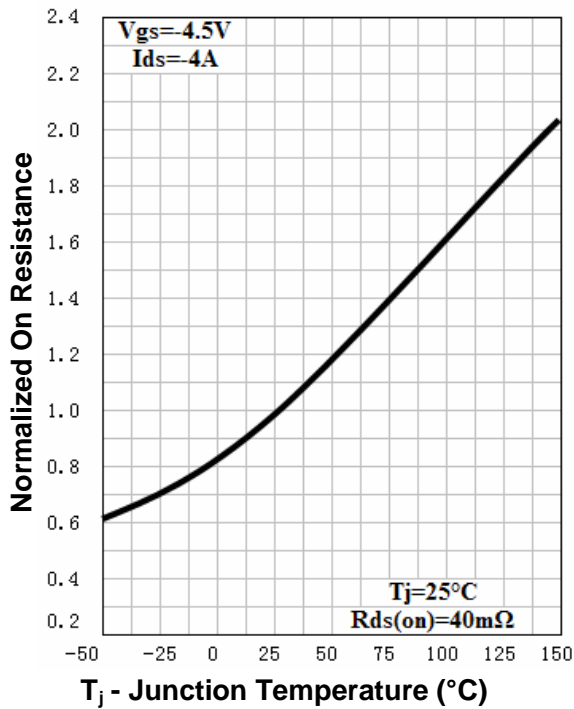

**Source-Drain Diode Forward**

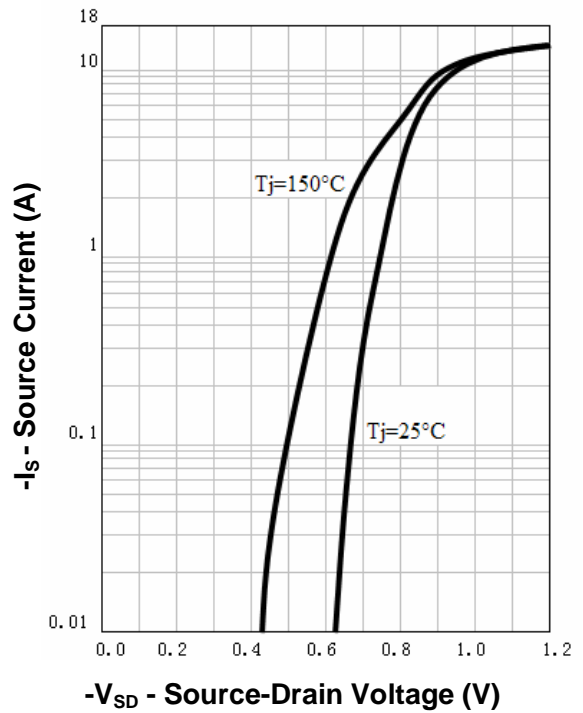

**Capacitance**

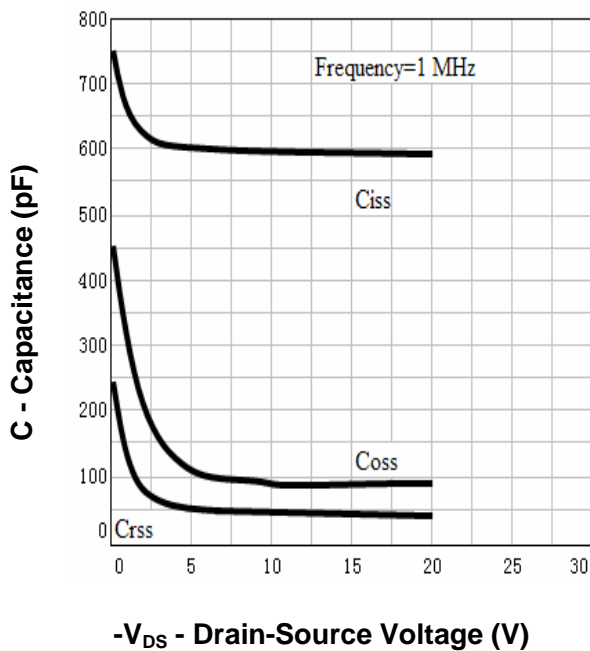

**Gate Charge**

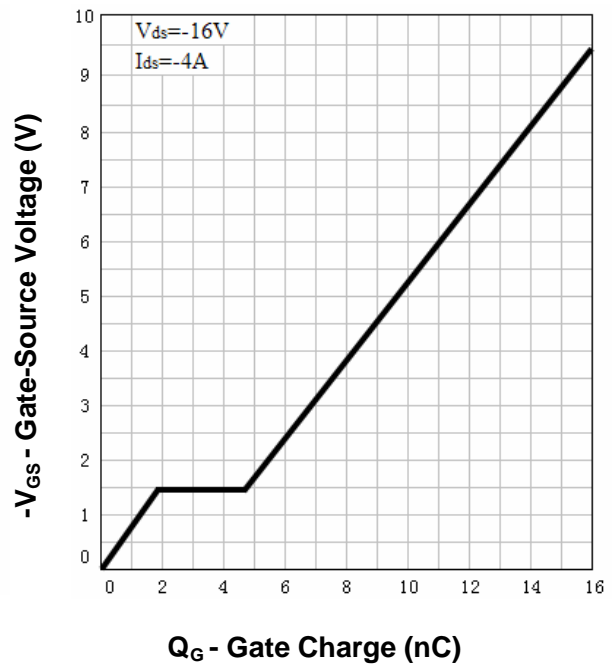

### Avalanche Test Circuit and Waveforms

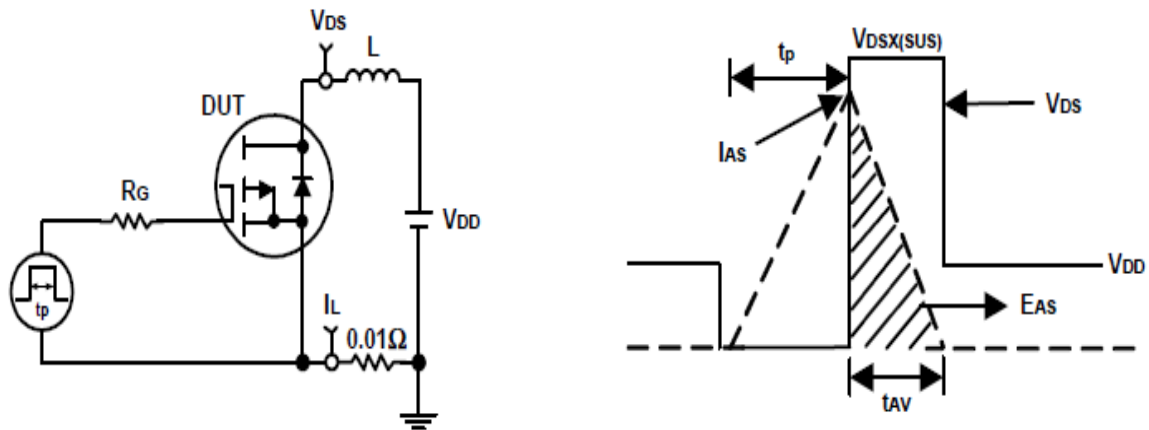

### Switching Time Test Circuit and Waveforms

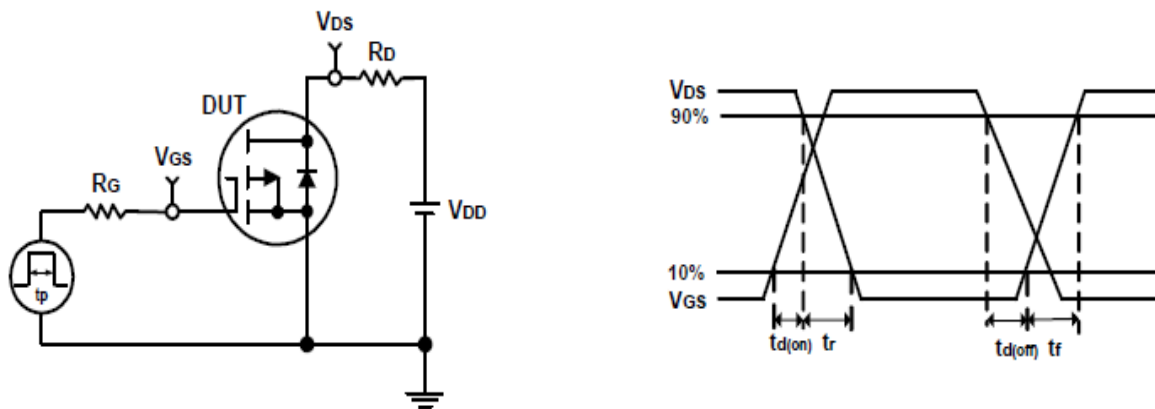

**Ordering and Marking Information****RU20P4****Package (Available)**

C : SOT-23-3

**Operating Temperature Range**

C : -55 to 150 °C

**Assembly Material**

G : Green &amp; Lead Free

**Packaging**

T : TUBE

TR : Tape &amp; Reel

**Package Information**

**SOT-23-3**

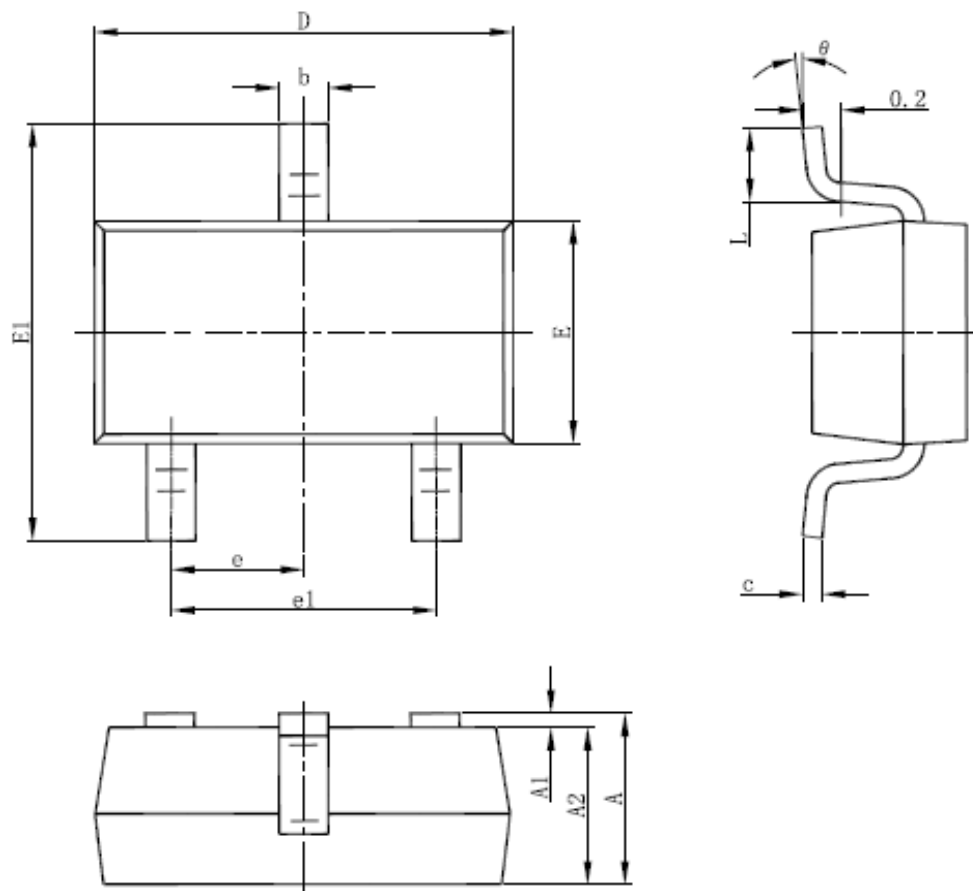

SYMBOL	MM		INCH		SYMBOL	MM		INCH	
	MIN	MAX	MIN	MAX		MIN	MAX	MIN	MAX
A	1.050	1.250	0.041	0.049	E	1.500	1.700	0.059	0.067
A1	0.0000	0.100	0.000	0.004	E1	2.650	2.950	0.104	0.116
A2	1.050	1.150	0.041	0.045	e	0.950(BSC)		0.037(BSC)	
b	0.300	0.500	0.012	0.020	e1	1.800	2.000	0.071	0.079
c	0.100	0.200	0.004	0.008	L	0.300	0.600	0.012	0.024
D	2.820	3.020	0.111	0.119	$\theta$	0°	8°	0°	8°

ALL DIMENSIONS REFER TO JEDEC STANDARD  
DO NOT INCLUDE MOLD FLASH OR PROTRUSIONS



## **Customer Service**

**Worldwide Sales and Service:**

Sales@ruichips.com

**Technical Support:**

Technical@ruichips.com

**Investor Relations Contacts:**

Investor@ruichips.com

**Marcom Contact:**

Marcom@ruichips.com

**Editorial Contact:**

Editorial@ruichips.com

**HR Contact:**

HR@ruichips.com

**Legal Contact:**

Legal@ruichips.com

**Shen Zhen RUICHIPS Semiconductor CO., LTD**

Room 501, the 5floor An Tong Industrial Building,  
NO.207 Mei Hua Road Fu Tian Area Shen Zhen City, CHINA

**TEL:** (86-755) 8311-5334

**FAX:** (86-755) 8311-4278

**E-mail:** Sales-SZ@ruichips.com