



iP7700 Constant Voltage and Constant Current Controller for Battery Chargers and Adapters

1. Description

The iP7700 is a highly integrated solution for SMPS (Switching Mode Power Supply) applications requiring a dual control loop to perform CV (constant voltage, current limit for Power Supply application) and CC (constant current, voltage limit for LED Driver application). The iP7700 integrates a voltage reference, two op amps (with OR-ed open-drain outputs), and a low-side current sensing circuit.

The voltage reference, along with one op amp, is the core of the voltage control loop; the current sensing circuit and the other op amp make up the current control loop.

The external components needed to complete the two control loops are:

- A resistor divider that senses the output of the power supply (adapter, battery charger) and fixes the voltage regulation set point at the specified value;
- A sense resistor that feeds the current sensing circuit with a voltage proportional to the dc output current; this resistor determines the current regulation set point and must be adequately rated in terms of power dissipation;
- Frequency compensation components (RC networks) for both loops.

The iP7700, housed in one of the smallest package is ideal for space-shrunk applications such as adapters and chargers.

2. Features

- Secondary-side constant voltage and constant current control
- Wide operation voltage 2.5-40 V
- Very low quiescent consumption
- High-accuracy internal reference
- Low external component count
- SOT23-6L micro package

3. Applications

- Battery chargers
- AC / DC adapters
- LED lighting

4. Pin Assignments

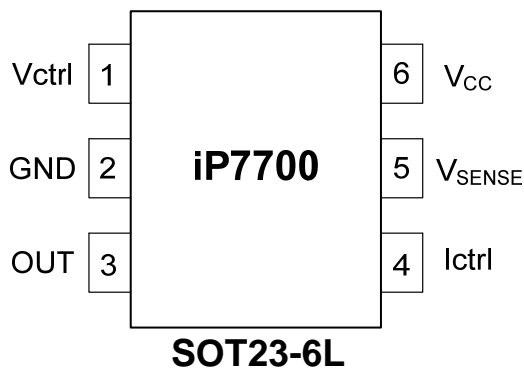

iP7700



5. Marking Information

Product Name	Marking
iP7700	7700X X : Date Code

6. Ordering Code

iP7700 □ └── Assembly Material	Assembly Material G: Halogen and Lead Free Device
-----------------------------------	--

Note: inergy defines “Green” as lead-free (RoHS compliant) and halogen free (Br or Cl does not exceed 900 ppm by weight in homogeneous material and total of Br and Cl does not exceed 1500 ppm by weight ; Follow IEC 61249-2-21 and IPC/JEDEC J-STD-020C)

7. Pin Definitions

Pin	Name	Description
1	Vctrl	Inverting input of the voltage loop op amp. The pin will be tied to the mid-point of a resistor divider that senses the output voltage.
2	GND	Ground. Return of the bias current of the device. 0 V reference for all voltages. The pin should be tied as close to the ground output terminal of the converter as possible to minimize load current effect on the voltage regulation set point.
3	OUT	Common open-drain output of the two internal op amps. This pin, able to sink current only, shall be connected to the branch of the optocoupler’s photodiode to transmit the error signal to the primary side.
4	Ictrl	Non-inverting input of the current loop op amp. It shall be tied directly to the hot (negative) end of the current sense resistor.
5	Vsense	Inverting input of the current loop op amp. This pin shall be tied to the cold end of the current sense resistor through a decoupling resistor.
6	Vcc	Supply Voltage of the device. A small bypass capacitor (0.1 μ F typ.) to GND, located as close to IC’s pins as possible, might be useful to get a clean supply voltage.

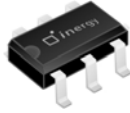

8. Block Diagram

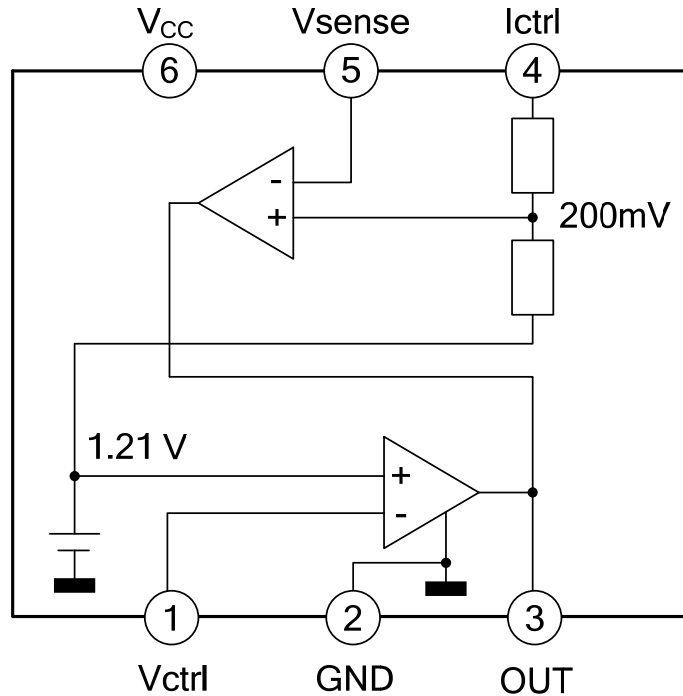

9. Absolute Maximum Ratings

Symbol	Parameter	Value	Unit
V_{CC}	DC supply voltage (Pin 6)	- 0.3 to 40	V
V_{OUT}	Open-drain voltage (Pin 3)	- 0.3 to 40	V
I_{OUT}	Max sink current (Pin 3)	100	mA
V	Analog inputs (Pin 1, 4, 5)	- 0.3 to 3.3	V

10. Thermal Data

Symbol	Parameter	Value	Unit
R_{thJA}	Thermal resistance, junction-to-ambient	250	$^{\circ}C / W$
T_{OP}	Junction temperature operating range	-40 to 85	$^{\circ}C$
T_{jmax}	Maximum junction temperature	150	
T_{STG}	Storage temperature	-55 to 150	



11. Electrical Characteristics ($T_J = 25\text{ }^\circ\text{C}$ and $V_{CC} = 5\text{ V}$, unless otherwise specified)

Symbol	Parameter	Conditions	Min.	Typ.	Max.	Unit
Device supply						
V_{CC}	Voltage operating range		2.5	-	40	V
I_{CC}	Quiescent current ($I_{ctrl} = V_{sense} = V_{ctr} = 0, OUT = open$)		-	70	-	μA
Current control loop						
G_{m_i}	Transconductance (sink current only) (2)		1.5	7	-	S
V_{sense}	Current loop reference @ $I(lout) = 1\text{ mA}$		196	200	204	mV
		(1)	192	-	208	
I_{bias}	Non-inverting input source current @ $V(Ictrl) = -200\text{ mV}$		-	20	-	μA
Voltage control loop op amp						
G_{m_v}	Transconductance (sink current only) (3)		1	2	-	S
V_{ref}	Voltage reference		1.198	1.21	1.222	V
		(1)	1.186	-	1.234	
I_{bias}	Inverting input bias current		-	50	-	nA
Output stage						
V_{OUTlow}	Low output level @ 2 mA sink current		-	75	-	mV

1. Specification referred to $-40\text{ }^\circ\text{C} < T_A < 85\text{ }^\circ\text{C}$
2. When the positive input at I_{ctrl} is lower than -200 mV , and the voltage is decreased by 1 mV , the sinking current at the output Out will be increased by 7 mA .
3. If the voltage on V_{ctrl} (the negative input of the amplifier) is higher than the positive amplifier input ($V_{ref} = 1.21\text{ V}$), and it is increased by 1 mV , the sinking current at the output OUT will be increased by 2 mA .

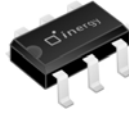

12. Typical Characteristics

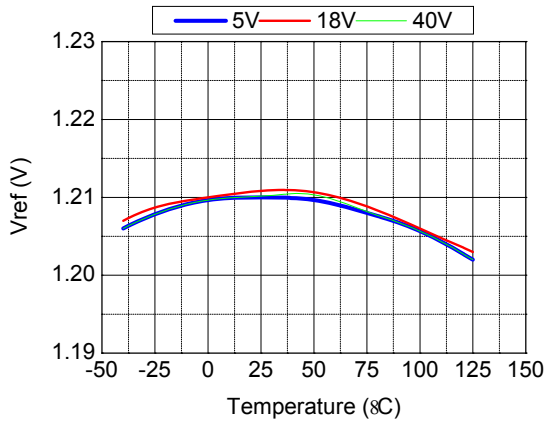

Figure 1. Vref vs. ambient temperature

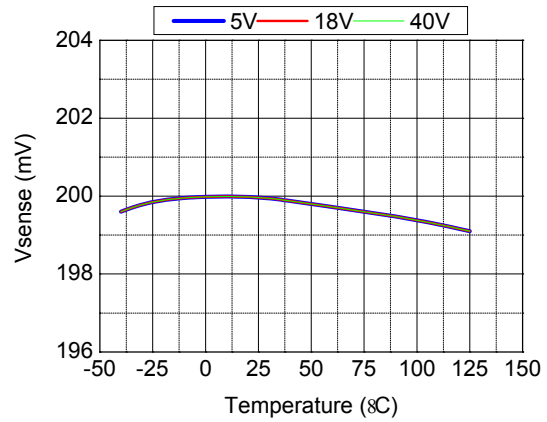

Figure 2. Vsense vs. ambient temperature

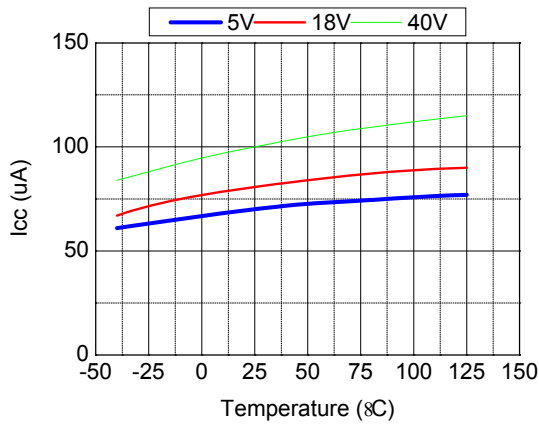

Figure 3. Supply current vs. ambient temperature

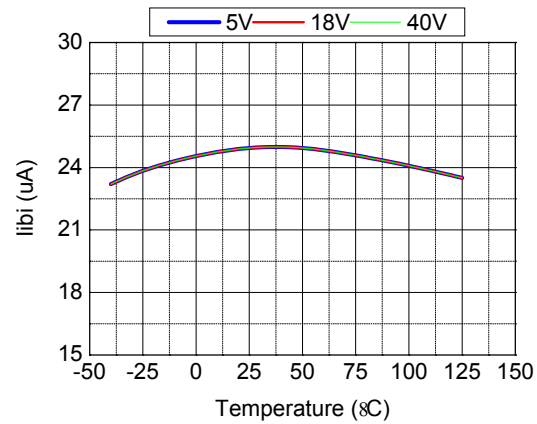

Figure 4. ICTRL pin input bias current vs. ambient temperature

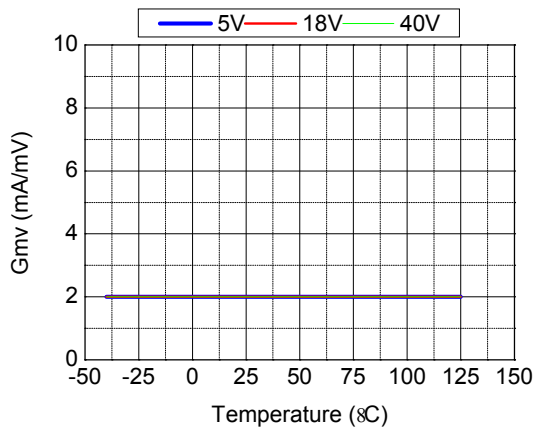

Figure 5. Transconductance(sink current only) of voltage control loop Op-Amp vs. ambient temperature

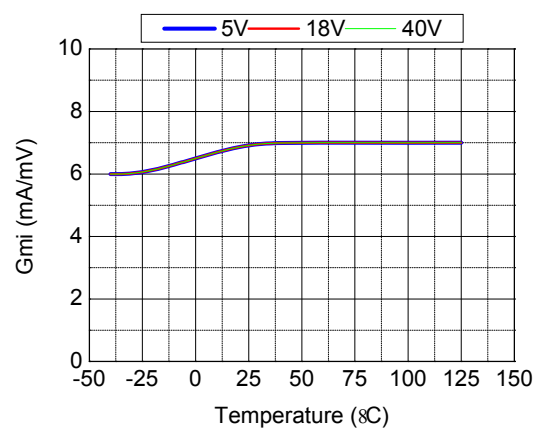
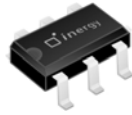

Figure 6. Transconductance(sink current only) of current control loop Op-Amp vs. ambient temperature



12. Typical Characteristics(cont.)

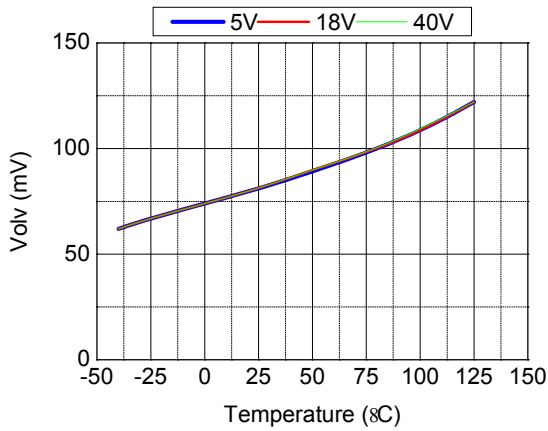

Figure 7. Low output level of voltage control loop Op-Amp vs. ambient temperature (2mA sink current)

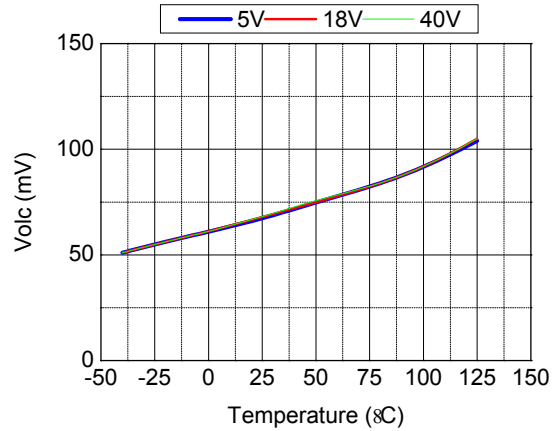

Figure 8. Low output level of current control loop Op-Amp vs. ambient temperature (2mA sink current)

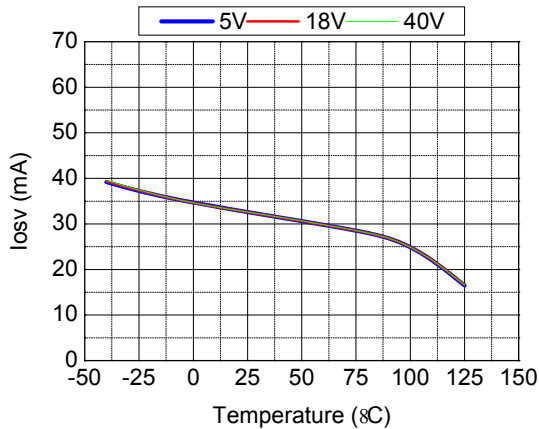

Figure 9. Output short circuit current of voltage control loop Op-Amp vs. ambient temperature

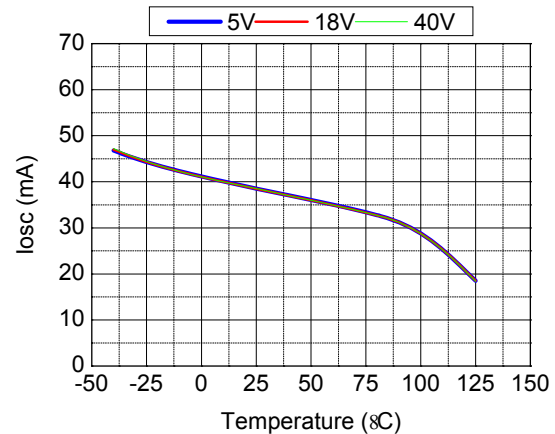

Figure 10. Output short circuit current of current control loop of Op-Amp vs. ambient temperature

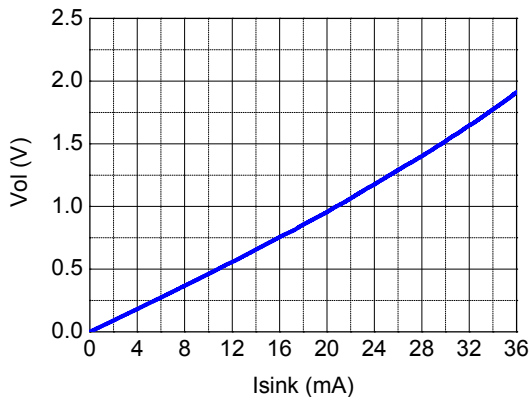
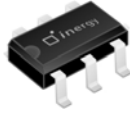
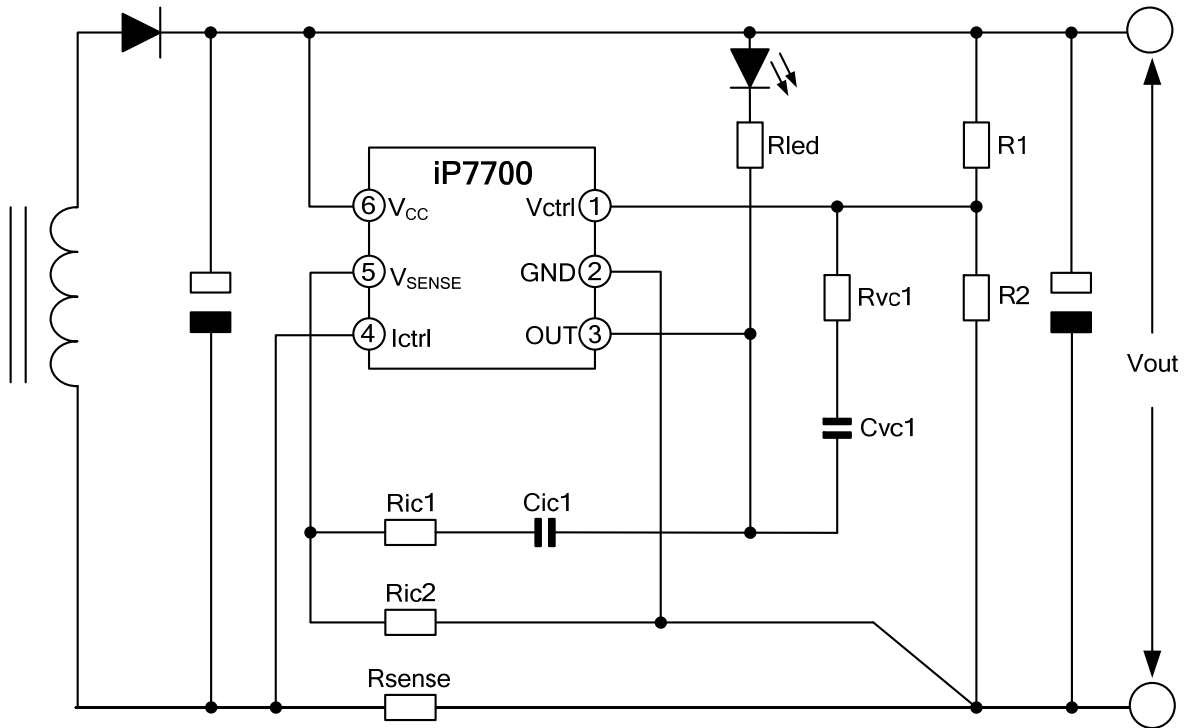

Figure 11. Low output level vs. sink current



13. Application Information

13.1 Typical application schematic



13.2 Voltage and current control

13.2.1 Voltage control

The voltage loop is controlled via a first transconductance operational amplifier, the voltage divider R_1 , R_2 , and the optocoupler which is directly connected to the output. V_{OUT} can be assigned by choosing the values of R_1 and R_2 resistors using Equation 1:

Equation 1

$$V_{OUT} = V_{ref} \cdot \frac{(R_1 + R_2)}{R_2}$$

where V_{out} is the desired output voltage, and V_{ref} is the threshold voltage for the voltage control loop. As an example, with $R_1 = 150 \text{ k}\Omega$ and $R_2 = 10 \text{ k}\Omega$, $V_{OUT} = 19.36 \text{ V}$.

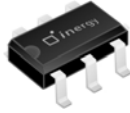

13.2.2 Current control

The current loop is controlled via the second transconductance operational amplifier, the sense resistor R_{sense} , and the optocoupler. The control equation verifies:

Equation 2

$$a) R_{sense} \cdot I_{lim} = V_{sense}$$

$$b) R_{sense} = \frac{V_{sense}}{I_{lim}}$$

where I_{lim} is the desired limited current, and V_{SENSE} is the threshold voltage for the current control loop. As an example, with $I_{lim} = 1 \text{ A}$, $V_{sense} = 200 \text{ mV}$, then $R_{sense} = 200 \text{ m}\Omega$.

Note : The R_{sense} resistor should be chosen taking into account the maximum dissipation (P_{lim}) through it during full load operation.

Equation 3

$$P_{lim} = V_{sense} \cdot I_{lim}$$

As an example, with $I_{lim} = 1 \text{ A}$, and $V_{SENSE} = 200 \text{ mV}$, $P_{lim} = 200 \text{ mW}$.

Therefore, for most adapter and battery charger applications, a quarter-watt, or half-watt resistor is sufficient. V_{SENSE} threshold is made internally by a voltage divider tied to the V_{ref} voltage reference. Its middle point is tied to the positive input of the current control operational amplifier, and its foot is to be connected to lower potential point of the sense resistor. The resistors of this voltage divider are matched to provide the best possible accuracy. The current sinking outputs of the two transconductance operational amplifiers are common (to the output of the IC). This makes an ORing function which ensures either the voltage control or the current control, driving the optocoupler's photodiode to transmit the feedback to the primary side.

The relation between the controlled current and the controlled output voltage can be described with a square characteristic as shown in the following V/I output-power diagram. (with the power supply of the device independent of the output voltage)

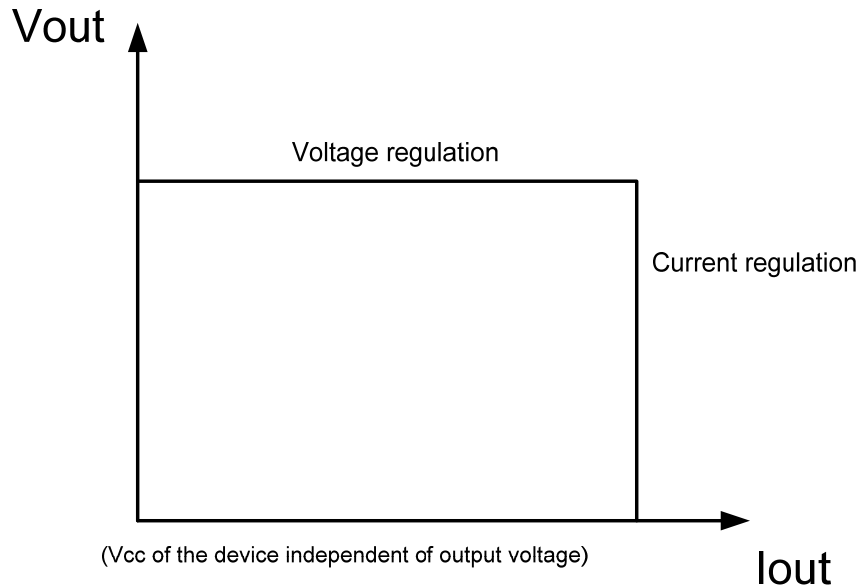
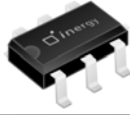

Output voltage versus Output current

13.3 Compensation

The voltage control transconductance operational amplifier can be fully compensated. Both of its output and negative input are directly accessible for external compensation components.

An example of a suitable compensation network is shown in typical application schematic. It consists of a capacitor $C_{VC1} = 47 \text{ nF}$ and a resistor $R_{VC1} = 470 \text{ k}\Omega$ in series.

The current control transconductance operational amplifier also can be fully compensated. Both of its output and negative input are directly accessible for external compensation components.

An example of a suitable compensation network is shown in typical application schematic. It consists of a capacitor $C_{IC1} = 100 \text{ nF}$ and a resistor $R_{IC1} = 10 \text{ k}\Omega$ in series.

In order to increase the stability of the application, the circuit could to add a resistor in series with the optocoupler. An example of a suitable R_{led} value could be $10 \text{ k}\Omega$ in series with the optocoupler.

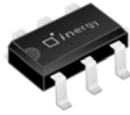

14. Package Dimensions SOT23-6L

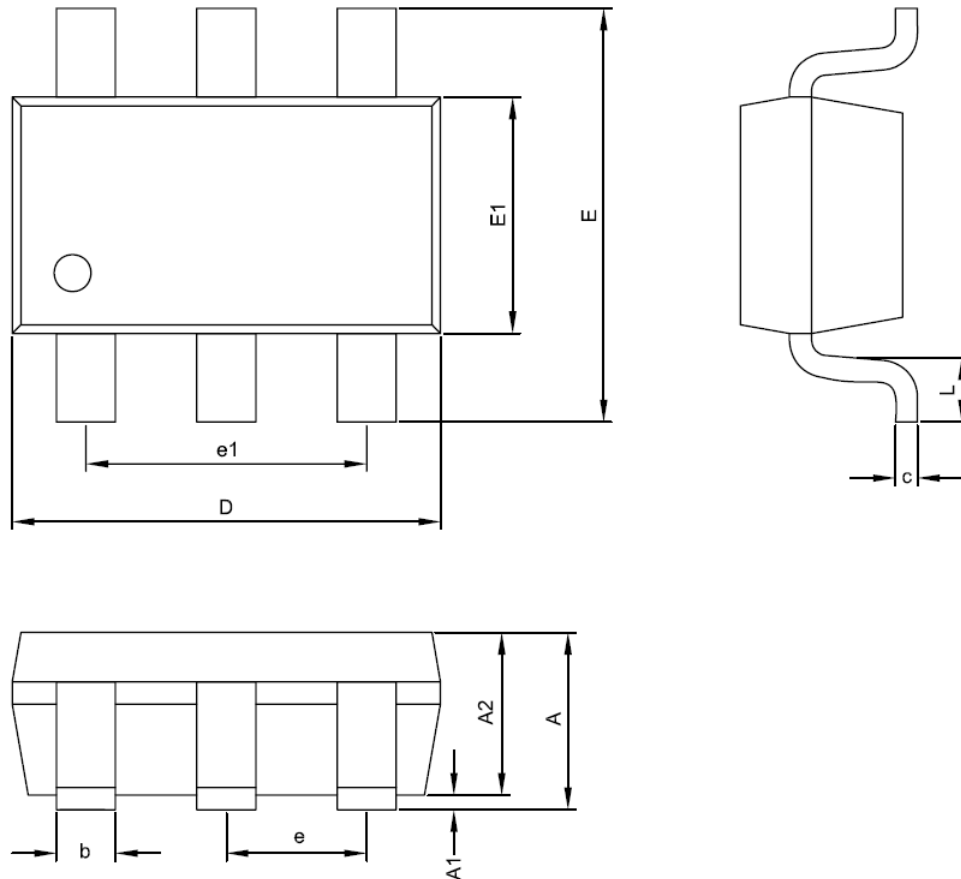

Symbol	Dimensions In Millimeters	
	MIN.	MAX.
A	—	1.45
A1	—	0.15
A2	0.90	1.30
D	2.90 BSC	
E	2.80 BSC	
E1	1.50	1.70
c	0.08	0.25
b	0.30	0.50
e	0.95 BSC	
e1	1.90 BSC	
L	0.30	0.60