

UL 1412

ISBN 0-7629-0450-X

Fusing Resistors and  
Temperature-Limited Resistors  
for Radio- and Television-  
Type Appliances



Underwriters Laboratories Inc. (UL)  
333 Pfingsten Road  
Northbrook, IL 60062-2096

UL Standard for Safety for Fusing Resistors and Temperature-Limited Resistors for Radio- and Television- Type Appliances, UL 1412

Fifth Edition, Dated August 30, 1999

Revisions: This Standard contains revisions through and including January 21, 2004.

### **SUMMARY OF TOPICS**

***This revision is being issued to remove the ANSI information from the title page as this Standard is no longer being maintained as an ANSI-approved Standard.***

UL Standards for Safety are developed and maintained in the Standard Generalized Markup Language (SGML). SGML -- an international standard (ISO 8879-1986) -- is a descriptive markup language that describes a document's structure and purpose, rather than its physical appearance on a page. Due to formatting differences resulting from the use of UL's new electronic publishing system, please note that additional pages (on which no requirements have been changed) may be included in revision pages due to relocation of existing text and reformatting of the Standard.

Text that has been changed in any manner is marked with a vertical line in the margin. Changes in requirements are marked with a vertical line in the margin and are followed by an effective date note indicating the date of publication or the date on which the changed requirement becomes effective.

The revisions dated January 21, 2004 include a reprinted title page (page1) for this Standard.

The master for this Standard at UL's Northbrook Office is the official document insofar as it relates to a UL service and the compliance of a product with respect to the requirements for that product and service, or if there are questions regarding the accuracy of this Standard.

UL's Standards for Safety are copyrighted by UL. Neither a printed copy of a Standard, nor the distribution diskette for a Standard-on-Diskette and the file for the Standard on the distribution diskette should be altered in any way. All of UL's Standards and all copyrights, ownerships, and rights regarding those Standards shall remain the sole and exclusive property of UL.

All rights reserved. No part of this publication may be reproduced, stored in a retrieval system, or transmitted in any form by any means, electronic, mechanical photocopying, recording, or otherwise without prior permission of UL.

Revisions of UL Standards for Safety are issued from time to time. A UL Standard for Safety is current only if it incorporates the most recently adopted revisions.

UL provides this Standard "as is" without warranty of any kind, either expressed or implied, including but not limited to, the implied warranties of merchantability or fitness for any purpose.

In no event will UL be liable for any special, incidental, consequential, indirect or similar damages, including loss of profits, lost savings, loss of data, or any other damages arising out of the use of or the inability to use this Standard, even if UL or an authorized UL representative has been advised of the possibility of such damage. In no event shall UL's liability for any damage ever exceed the price paid for this Standard, regardless of the form of the claim.

UL will attempt to answer support requests concerning electronic versions of its Standards. However, this support service is offered on a reasonable efforts basis only, and UL may not be able to resolve every support request. UL supports the electronic versions of its Standards only if they are used under the conditions and operating systems for which it is intended. UL's support policies may change from time-to-time without notification.

UL reserves the right to change the format, presentation, file types and formats, delivery methods and formats, and the like of both its printed and electronic Standards without prior notice.

Purchasers of the electronic versions of UL's Standards for Safety agree to defend, indemnify, and hold UL harmless from and against any loss, expense, liability, damage, claim, or judgement (including reasonable attorney's fees) resulting from any error or deviation introduced while purchaser is storing an electronic Standard on the purchaser's computer system.

If a single-user version electronic Standard was purchased, one copy of this Standard may be stored on the hard disk of a single personal computer, or on a single LAN file-server or the permanent storage device of a multiple-user computer in such a manner that this Standard may only be accessed by one user at a time and for which there is no possibility of multiple concurrent access.

If a multiple-user version electronic Standard was purchased, one copy of the Standard may be stored on a single LAN file-server, or on the permanent storage device of a multiple-user computer, or on an Intranet server. The number of concurrent users shall not exceed the number of users authorized.

Electronic Standards are intended for on-line use, such as for viewing the requirements of a Standard, conducting a word search, and the like. Only one copy of the Standard may be printed from each single-user version of an electronic Standard. Only one copy of the Standard may be printed for each authorized user of a multiple-user version of an electronic Standard. Because of differences in the computer/software/printer setup used by UL and those of electronic Standards purchasers, the printed copy obtained by a purchaser may not look exactly like the on-line screen view or the printed Standard.

An employee of an organization purchasing a UL Standard can make a copy of the page or pages being viewed for their own fair and/or practical internal use.

The requirements in this Standard are now in effect, except for those paragraphs, sections, tables, figures, and/or other elements of the Standard having future effective dates as indicated in the note following the affected item. The prior text for requirements that have been revised and that have a future effective date are located after the Standard, and are preceded by a "SUPERSEDED REQUIREMENTS" notice.

A change in an effective date is indicated by a note following the affected item, and giving both the previous effective date and the new date the requirement becomes effective.

New product submittals made prior to a specified future effective date will be judged under all of the requirements in this Standard including those requirements with a specified future effective date, unless the applicant specifically requests that the product be judged under the current requirements. However, if the applicant elects this option, it should be noted that compliance with all the requirements in this Standard will be required as a condition of continued Listing, Recognition and Follow-Up Services after the effective date, and understanding of this should be signified in writing.

Copyright © 2004 Underwriters Laboratories Inc.

This Standard consists of pages dated as shown in the following checklist:

Page	Date
1-3 .....	January 21, 2004
4-6 .....	August 30, 1999
7-8B .....	January 21, 2004
9-18 .....	August 30, 1999

No Text on This Page

**AUGUST 30, 1999**

(Title Page Reprinted: January 21, 2004)

1

**UL 1412**

**Standard for Fusing Resistors and Temperature-Limited Resistors for  
Radio- and Television- Type Appliances**

The First edition was titled Fusing Resistors and Failsafe Resistors for Radio and Television Receiving Appliances and Other Electronic Equipment and numbered UL 492.2.

First Edition – August, 1974

Second Edition – October, 1980

Third Edition – July, 1988

Fourth Edition – July, 1994

**Fifth Edition**

**August 30, 1999**

An effective date included as a note immediately following certain requirements is one established by Underwriters Laboratories Inc.

Revisions of this Standard will be made by issuing revised or additional pages bearing their date of issue. A UL Standard is current only if it incorporates the most recently adopted revisions, all of which are itemized on the transmittal notice that accompanies the latest set of revised requirements.

**ISBN 0-7629-0450-X**

**COPYRIGHT © 1974, 2004 UNDERWRITERS LABORATORIES INC.**

No Text on This Page



**CONTENTS**

<b>FOREWORD</b> .....	6
-----------------------	---

**GENERAL**

1 Scope .....	7
2 Glossary .....	7
3 References .....	8

**CONSTRUCTION**

4 General .....	8
5 Corrosion Protection .....	8
6 Insulating Material .....	.8A
7 Spacings .....	9
8 Mounting .....	9

**PERFORMANCE****GENERAL**

9 Arc Resistance Test .....	10
10 High-Current Arcing Test .....	10
11 Hot-Wire Ignition Test .....	10
12 Resistance to Moisture Test .....	10
13 Strain Relief Test .....	10
14 Torque Test .....	10

**FUSING RESISTORS**

15 Overload Test .....	11
16 Positive Opening Test .....	11
17 Opening-Time Calibration Tests .....	12
18 Limited Short Circuit Test .....	12
19 Dielectric Voltage-Withstand Test .....	12

**TEMPERATURE-LIMITED RESISTORS**

20 Representative Devices .....	13
21 Overload Test .....	13
21.1 Gradual overload test .....	13
21.2 Sudden overload test .....	13
21.3 Open resistor .....	17
22 Dielectric Voltage-Withstand Test .....	17
23 Dielectric Voltage-Withstand Test Repeated (Optional) .....	17

**RATING**

24 Details .....	18
------------------	----

**MARKING**

25 Details .....18

No Text on This Page

## FOREWORD

A. This Standard contains basic requirements for products covered by Underwriters Laboratories Inc. (UL) under its Follow-Up Service for this category within the limitations given below and in the Scope section of this Standard. These requirements are based upon sound engineering principles, research, records of tests and field experience, and an appreciation of the problems of manufacture, installation, and use derived from consultation with and information obtained from manufacturers, users, inspection authorities, and others having specialized experience. They are subject to revision as further experience and investigation may show is necessary or desirable.

B. The observance of the requirements of this Standard by a manufacturer is one of the conditions of the continued coverage of the manufacturer's product.

C. A product which complies with the text of this Standard will not necessarily be judged to comply with the Standard if, when examined and tested, it is found to have other features which impair the level of safety contemplated by these requirements.

D. A product employing materials or having forms of construction which conflict with specific requirements of the Standard cannot be judged to comply with the Standard. A product employing materials or having forms of construction not addressed by this Standard may be examined and tested according to the intent of the requirements and, if found to meet the intent of this Standard, may be judged to comply with the Standard.

E. UL, in performing its functions in accordance with its objectives, does not assume or undertake to discharge any responsibility of the manufacturer or any other party. The opinions and findings of UL represent its professional judgment given with due consideration to the necessary limitations of practical operation and state of the art at the time the Standard is processed. UL shall not be responsible to anyone for the use of or reliance upon this Standard by anyone. UL shall not incur any obligation or liability for damages, including consequential damages, arising out of or in connection with the use, interpretation of, or reliance upon this Standard.

F. Many tests required by the Standards of UL are inherently hazardous and adequate safeguards for personnel and property shall be employed in conducting such tests.

## GENERAL

### 1 Scope

1.1 These requirements cover fusing resistors and temperature-limited resistors to be employed in radio- and television-type appliances. These requirements also apply to resistor mounting assemblies intended for use with such resistors. The purpose of these requirements is to reduce the risk of fire or electric shock by use of those resistors, but compliance of a resistor with the following requirements does not mean that it is acceptable for all applications without evaluation in the appliance.

1.2 These requirements cover fusing resistors and temperature-limited resistors for use in radio- and television-type appliances in circuits that do not involve potentials greater than 2500 V peak.

1.3 *Deleted January 21, 2004*

### 2 Glossary

2.1 FUSING RESISTOR – A resistor intended to interrupt a current flow at a predetermined time when the current passing through it exceeds a predetermined value. It is nonrenewable, (in other words – it is intended to be replaced following operation).

2.2 RESISTOR MOUNTING ASSEMBLY – A part that is required to secure the resistor in the appliance. It may be on, or separate from the resistor body, exclusive of pigtail leads.

2.3 TEMPERATURE-LIMITED RESISTOR – A resistor whose body temperature does not exceed 600°C (1112°F) or flame when overload tested in accordance with Overload Test, Section 21. It is intended to provide circuit impedance and not overcurrent protection.

2.4 TRANSITION POINT – The point in a line of resistors at which there is a basic construction change, such as a change in resistive element (size or material), physical size of resistor body, material, and voltage rating (see 2.5 ).

2.5 VOLTAGE RATING – The voltage assigned by the manufacturer as the maximum voltage to which the resistor may be subjected – that is, the voltage capability of the end-product power supply, under any fault condition, at the point where a resistor is used in a circuit. The maximum voltage shall not exceed the voltage rating of the resistor.

### 3 References

Section 3 added August 30, 1999

3.1 Any undated reference to a code or standard appearing in the requirements of this standard shall be interpreted as referring to the latest edition of that code or standard.

### CONSTRUCTION

#### 4 General

4.1 A fusing resistor shall comply with the requirements in Sections 5, 8, 15 – 19, 24, and 25, as applicable.

4.2 A temperature-limited resistor shall comply with the requirements in Sections 5, 8, and 20 – 25, as applicable.

4.3 A resistor mounting assembly shall comply with the requirements in Sections 5 – 14 and 19.1 and 19.2.

4.4 The acceptability of a resistor covered by these requirements in any particular device or appliance depends upon its effectiveness for continued use under the conditions that prevail in actual service. Accordingly, for a particular application, the resistor may be affected by the requirements for the device or appliance in question, and it may be necessary to employ protective devices having features other than or in addition to those specified in these requirements.

#### 5 Corrosion Protection

5.1 All metal parts necessary for proper functioning of the resistor assembly shall be protected against corrosion.

*Exception: Parts made of nonferrous metal (properly coated or treated if necessary) do not require additional protection against corrosion.*

5.2 5.1 applies to all enclosing cases, and to all other parts upon which proper operation may depend.

5.3 Small, minor, noncurrent-carrying parts of iron or steel such as washers or screws need not be provided with corrosion protection unless the part ceases to perform its intended function and results in a risk of fire or electric shock.

## 6 Insulating Material

6.1 Insulating material for the support of current-carrying parts of a resistor mounting assembly shall be investigated to determine that it complies with all of the following:

- a) Insulating material shall have the mechanical strength needed for the application.
- b) Insulating material shall be classified at least V-0 as described in the Standard Tests for Flammability of Plastic Materials for Parts in Devices and Appliances, UL 94.
- c) Insulating material shall be resistant to arcing, as described in Arc Resistance Test, Section 9 and High-Current Arcing Test, Section 10.
- d) Insulating material shall be resistant to flaming from hot-wire ignition, as described in Hot-Wire Ignition Test, Section 11.
- e) Insulating material shall be resistant to moisture, as described in Resistance to Moisture Test, Section 12.

No Text on This Page



6.2 6.1 is intended to apply to terminal-support materials and holders of plug-in-type resistors. It is not intended to apply to coatings or enclosing cases except where employed as direct support of current-carrying parts.

## 7 Spacings

7.1 The spacings of a resistor and its mounting assembly shall not be less than those specified in Table 7.1 between any uninsulated live part and:

- a) Uninsulated live parts of opposite polarity, and
- b) Uninsulated dead metal parts.

**Table 7.1**  
**Minimum acceptable spacing**

Potential involved in volts (RMS)	Over surface, inch (mm)	Through air, inch (mm)
0 – 125	1/16 (1.6)	1/16 (1.6)
126 – 250	3/34 (2.4)	3/32 (2.4)
251 – 600	3/16 (4.8)	5/32 (4.0)
601 – 2500	5/16 (7.9)	3/16 (4.8)

7.2 Uninsulated live parts, including terminals, shall be secured to their supporting surfaces by methods other than friction between surfaces so that they are prevented from turning or shifting in position if such motion may result in reduction of spacings to less than those required elsewhere in this Standard.

## 8 Mounting

8.1 A resistor and its mounting assembly, when provided, shall not be adversely affected by strain, pressure, or torsion on terminals or leads as determined by the tests described in Strain Relief Test, Section 13 and Torque Test, Section 14.

8.2 Bolts, screws, or other parts used for mounting a device shall be independent of those used for securing parts of the assembly. In other words, the mounting means shall not be the assembly means.

## PERFORMANCE

### GENERAL

#### 9 Arc Resistance Test

9.1 If a material of a resistor assembly is required to be arc resistant, the material shall be arc resistant to the extent that tracking does not occur before 180 seconds when tested in accordance with the Standard Methods of Test for High-Voltage, Low-Current Dry Arc Resistance of Solid Electrical Insulation, ASTM D 495-89 and/or to the extent described in High-Current Arcing Test, Section 10.

*Exception: At the manufacturer's option, completed representative resistor mounting assemblies may be used instead of the rectangular specimens mentioned in 12.2.*

#### 10 High-Current Arcing Test

10.1 Each of three specimens of a material that is to be evaluated for resistance to low-voltage arcing is to be tested as described in the Standard for Polymeric Materials – Short-Term Property Evaluations, UL 746A. There is to be no ignition of the representative test devices with fewer than 30 electrical arcs.

#### 11 Hot-Wire Ignition Test

11.1 If a material of a resistor mounting assembly is required to be resistant to flaming from hot-wire ignition, there shall be no ignition of any representative device within 15 seconds when the material is tested as described in the Standard for Polymeric Materials – Short-Term Property Evaluations, UL 746A.

#### 12 Resistance to Moisture Test

12.1 If a material of a resistor mounting assembly is required to be moisture resistant, the volume resistivity, when measured in accordance with the Standard Method of Test for D-C Resistance or Conductance of Insulating Materials, ASTM D 257-92, shall be a minimum of 10 megohm centimeters after conditioning as described in 12.2. Further, the initial (that is, before conditioning) volume resistivity shall be a minimum of 50 megohm centimeters.

12.2 Each of three flat, circular, or rectangular specimens of the material nominally 4 inches (102 mm) square or diameter and 1/8 inch (3.2 mm) thick (or in the thickness actually used) is to be placed in a 32.0 ±3.0°C (91.4 ±5.4°F), 85 ±5 percent relative humidity environment for 96 hours.

*Exception: At the manufacturer's option, an appropriate moisture-resistance test may be of the resistor mounting assembly conducted on completed representative devices.*

#### 13 Strain Relief Test

13.1 A lead or terminal shall be capable of withstanding for 1 minute, without sustaining damage to itself or the component, a force of 5 lbf (22.2 N) applied in any direction possible with the construction.

#### 14 Torque Test

14.1 A tab, terminal, or tang of a resistor or resistor mounting assembly shall be capable of withstanding for 1 minute without sustaining damage to itself or the component a torque of 10 inch-ounces (0.07 N·m) applied at a right angle to the direction of the terminal extension from the component.

14.2 An axial wire lead shall be capable of withstanding without lead breakage or damage to the resistor body the torsion test described in 14.3.

14.3 Each lead is to be bent through 90 degrees at a point 1/4 inch (6.4 mm) from the point of emergence of the lead. The radius of curvature of the bend is to be approximately 1/32 inch (0.8 mm). The free end of the lead is to be clamped to within 3/64  $\pm$  1/64 inch (1.2  $\pm$  0.4 mm) of the bend. The body of the component or the clamped terminal is then to be rotated through 360 degrees about the original axis of the terminal. The rate of rotation is to be 2 – 5 seconds per 360 degrees. Successive rotations are to be in alternate directions. A total of three such 360 degree rotations is to be performed after which the component is to be visually examined for evidence of lead breakage or damage to the resistor body.

## FUSING RESISTORS

### 15 Overload Test

15.1 A resistor shall withstand the overload test described in this section without resulting in a fire.

15.2 A single layer of cheesecloth is to be wrapped around, and be in contact with, the resistor under test.

*Exception: At the manufacturer's option, the cheesecloth may be spaced 1/2 inch (127 mm) – or 1 inch (25.4 mm) for a resistor rated greater than 10 W – from the resistor body as described herein. In this case, a positive spacing of 1/2 inch (or 1 inch, as appropriate) between the resistor body and combustible materials is to be provided in the complete appliance. A single layer of cheesecloth is to be placed around the resistor under test to form a cylinder with open ends. The length of the cylinder is not to be less than three times the length of the resistor body and the diameter of the cylinder is to be such that the cheesecloth is spaced 1/2 inch (or 1 inch, as appropriate) from the outermost part of the resistor body. The resistor body is to be centered end-to-end within the cylinder and the longitudinal axis of the resistor body is to be coincident with the longitudinal axis of the cylinder.*

15.3 The resistor is to be connected to a 60-Hz variable voltage source of supply fused at 30 A. Prior to energizing, the supply voltage is to be adjusted to produce rated current (or rated power dissipation) in the resistor. At 1-minute intervals after energizing, the supply voltage is to be raised in steps of 2, 3, 4, 5, and so forth, times that initial voltage until the resistor opens. In no case is the voltage rating of the resistor to be exceeded.

15.4 Five complete separate tests are to be made using new samples for each test.

15.5 The results are not acceptable if the cheesecloth flames.

15.6 The cheesecloth used for the overload test shall be untreated cotton cloth 36 inches (0.9 m) wide, running 14 – 15 yd<sup>2</sup> /lb and having what is known to the trade as a count of 32 by 28.

### 16 Positive Opening Test

16.1 The opening of a fusing resistor shall be positive.

16.2 Each representative resistor that has been previously subjected to the overload test is to be connected to a 60-Hz variable voltage source of supply. The voltage is to be adjusted to the same value that produced opening of the resistor during the overload test and the resulting current flow, if any, is to be measured. The measurement is to be made not less than 3 minutes nor more than 5 minutes following the opening of the resistor as a result of the overload test. The measured current flow is not to exceed 1 percent of the rated resistor current.

## 17 Opening-Time Calibration Tests

17.1 For the calibration tests, the fusing resistor is to be mounted in its intended manner.

17.2 If a range of values for one component construction is to be evaluated, representative resistors of the minimum, mean, and maximum rating are to be tested. All tests are to be conducted in a  $25.0 \pm 3.0^\circ\text{C}$  ( $77.0 \pm 5.4^\circ\text{F}$ ) ambient.

17.3 The opening time of a fusing resistor shall be consistent and in accordance with the tolerances specified by the manufacturer's curve of opening time versus current or wattage.

17.4 The manufacturer's opening time curve is to be verified by checking four points, including high and low values, along the curve. Five separate representative resistors are to be used to check each of the four points.

17.5 Each representative resistor is to be connected to a 60-Hz variable voltage source of supply. Prior to energizing, the supply voltage is to be adjusted to produce the desired current or power dissipation in the resistor. The opening time of each resistor is to be measured and compared with the manufacturer's curve.

## 18 Limited Short Circuit Test

18.1 When a fusing resistor is tested as described in 18.2 there shall be no evidence of risk of fire or electric shock during or after the test.

*Exception: If, as requested by the manufacturer, this test is not conducted, the fusing resistor is to be tested in the complete appliance.*

18.2 Twelve representative devices of each fusing resistor are to be mounted in their holders where applicable and subjected to a limited short circuit from a 120-V, 60-Hz branch circuit. A 20-A nonrenewable fuse, the characteristics of which are such that the fuse does not open in less than 12 seconds when carrying 40 A, is to be connected in series with the resistor. The circuit is to limit the current to 1000 A rms measured without the resistor in the circuit. The power factor of the circuit is to be 0.9– 1.0. The resistor or holder, if applicable is to be connected in the circuit by two 5-1/2 foot (1.4 m) lengths of No. 18 AWG ( $0.82 \text{ mm}^2$ ) copper wire. Cotton is to be wrapped around the resistor or combination. Each dead metal part is to be connected to earth ground through a 1-A fuse.

18.3 The results are acceptable if:

- a) The resistor opens the circuit without ignition of the cotton,
- b) There is no damage to the leads or terminals of the component, and
- c) The 1-A fuse has not opened.

## 19 Dielectric Voltage-Withstand Test

19.1 A resistor – or a resistor and its mounting means, if provided – shall withstand without breakdown for a period of not less than 1 minute a 60-Hz potential of 1000 V plus twice the rated voltage applied between live parts and dead metal parts, if any.

*Exception: For a resistor intended for use in circuits of 600 V or less, the test potential is to be three times rated voltage but not less than 900 V rms.*

19.2 Ten representative devices are to be tested for compliance with regard to dielectric voltage-withstand capability between live parts and dead metal parts.

19.3 A resistor employing an enclosure or coating of insulating material shall withstand without breakdown for a period of not less than 1 minute a 60-Hz potential of 1000 V plus twice the rated voltage applied between both terminals of the component connected together and metal foil wrapped closely around the body of the component.

*Exception No. 1: For a resistor intended for use in circuits of 600 V or less, the test potential is to be three times rated voltage but not less than 900 V rms.*

*Exception No. 2: The test described in 19.3 need not be conducted if positive spacings between the resistor body and uninsulated parts of opposite polarity or uninsulated dead metal parts are provided in the complete appliance.*

19.4 Ten representative devices are to be tested for compliance with regard to the dielectric voltage withstand capability described in 19.3. The metal foil is to be kept at least 1/16 inch (1.6 mm) from the terminals or leads of the component or from uninsulated live parts.

## TEMPERATURE-LIMITED RESISTORS

### 20 Representative Devices

20.1 There shall be one sample value selected for testing on each side of a transition point. The sampling may be expanded to include additional representative resistors of the same or different values at points of question or inconsistency or further interest.

### 21 Overload Test

#### 21.1 Gradual overload test

21.1.1 A resistor shall not flame or attain a surface temperature of 600°C (1,112°F) during a gradual overload test.

21.1.2 To determine compliance with 21.1.1, representative devices of a temperature-limited resistor shall be subjected to a gradual overload by applying a direct-current voltage that shall, at the start cause rated wattage dissipation in the resistor; and then at 1 minute intervals the applied voltage shall be increased to cause the wattage dissipation to increase in steps of 1, 2, 3, 4, 5, and so forth, times the rated wattage of the resistor being tested until one of the following results occurs:

- a) The applied voltage equals the resistor voltage rating (see 2.5 ).
- b) The resistor opens the test circuit (see 21.3.1 ).

21.1.3 The circuit and apparatus for performing the gradual overload test is shown in Figure 21.1.

#### 21.2 Sudden overload test

21.2.1 There shall be no flaming of a resistor as a result of a sudden overload.

Figure 21.1  
Overload test equipment and circuit

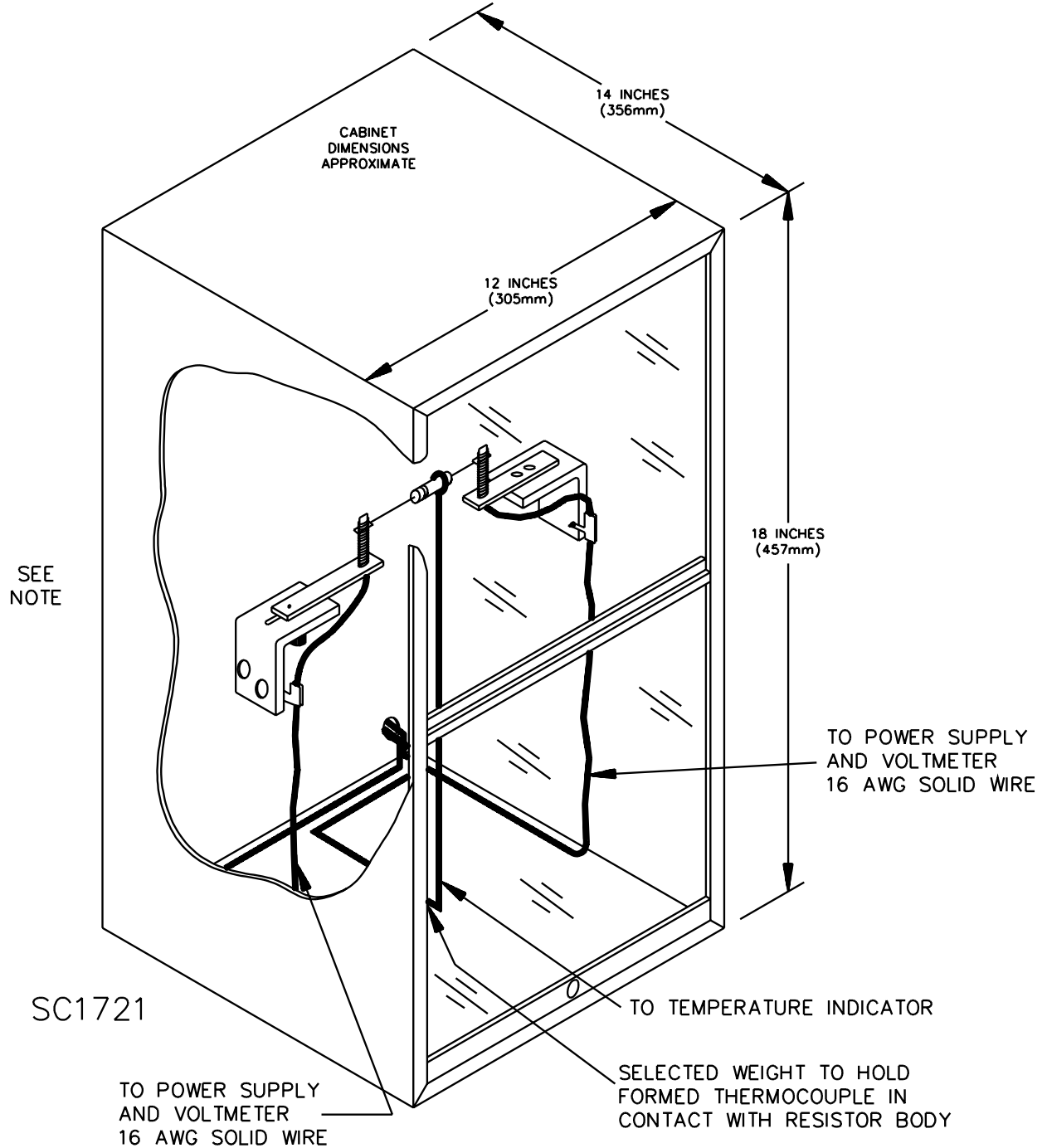
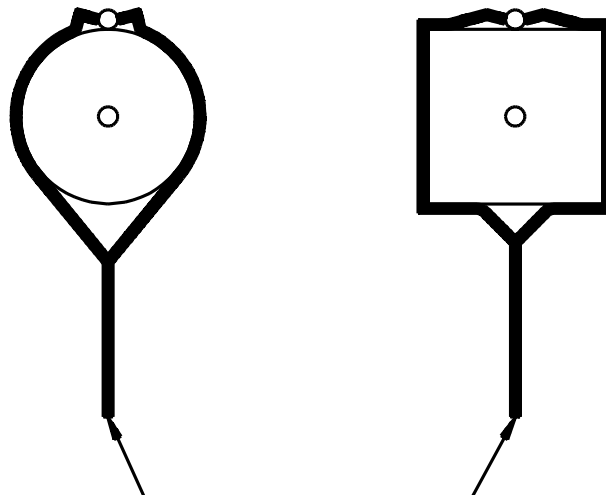
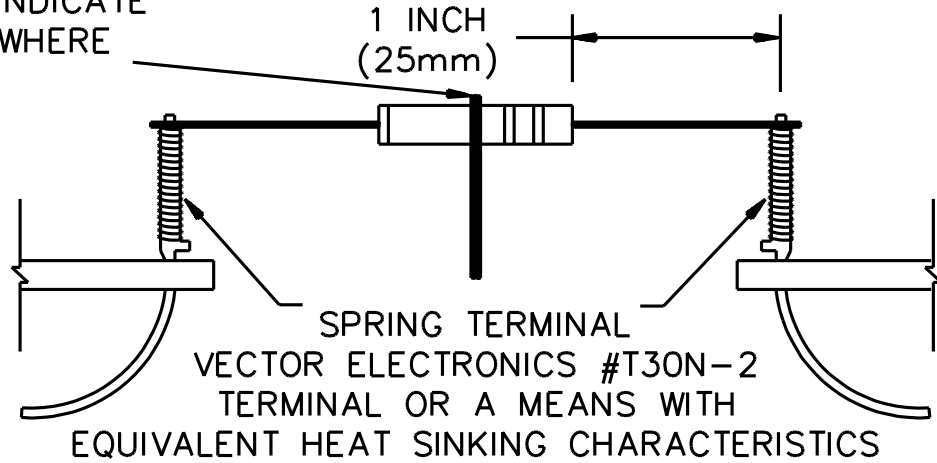

Figure 21.1 (Cont.)

THERMOCOUPLE TO BE  
LOCATED AT CENTER  
EXCEPT FOR CONSTRUCT-  
ION THAT MAY INDICATE  
HOT SPOT ELSEWHERE



THERMOCOUPLES  
TYPE "K" 30AWG, COTTON BRAIDED  
FORMED AROUND RESISTOR

SB1835A

Figure 21.1 (Cont.)

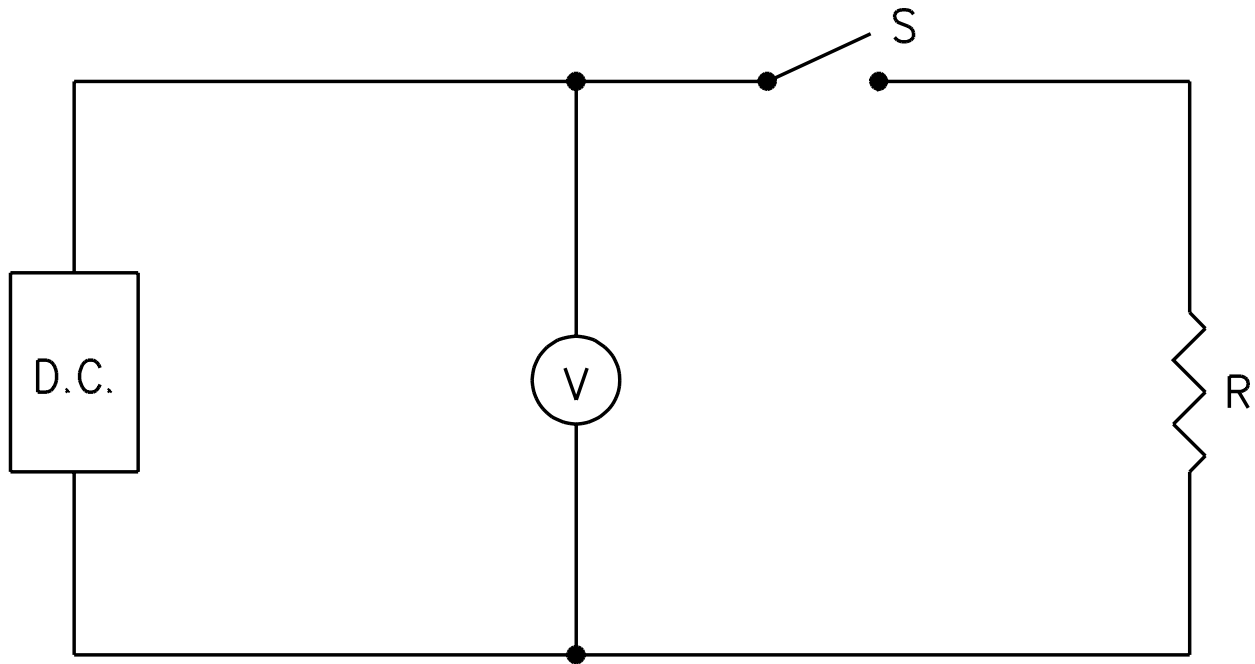

SB1722

- DC – D.C. POWER SUPPLY
- V – DIGITAL VOLTMETER
- S – SWITCH
- R – RESISTOR UNDER TEST

NOTE: MOUNTING BRACKETS ARE TO BE SO LOCATED FROM ENCLOSURE WALLS THAT AIR CIRCULATION IS PROVIDED AND A HEAT SINKING EFFECT OF WALL SURFACES DOES NOT RESULT.



21.2.2 To determine compliance with 21.2.1, representative resistors shall be subject to a sudden overload by applying a direct-current voltage that causes a power dissipation in the resistor that is 20 times the wattage rating of the resistor, but in no case shall the applied voltage be greater than the voltage rating of the resistor. See 2.5. If the resistor does not open within 5 minutes (see 21.3.1) after the application of the test voltage, the test on that sample shall be terminated. A new sample shall then be tested with the test voltage increased to cause a wattage dissipation increase of 5 W. This procedure shall be followed repeatedly until the circuit opens. The determination of flame can usually be made visually and in cases where the use of a flame indicator is required, surgical cotton shall be placed around the resistor body.

### **21.3 Open resistor**

21.3.1 A resistor is considered to have opened when there is an abrupt change and continuous drop in temperature.

## **22 Dielectric Voltage-Withstand Test**

22.1 One previously untested representative resistor of the same value as the one tested according to 21.1.1 shall withstand without breakdown for a period of not less than 1 minute at 60-Hz.

- a) For Resistors Rated 600 V or More— The rated voltage plus 1000 V.
- b) For Resistors Rated Less Than 600 V – Twice the rated voltage but not less than 1080 V.

*Exception: The dielectric voltage-withstand test in 22.2 need not be conducted if positive spacings between the resistor body and uninsulated parts of opposite polarity or uninsulated dead metal parts are to be provided in the complete appliance.*

22.2 The voltage shall be applied between the resistor leads and metallic foil placed around the resistor body. The foil shall cover as much of the resistor body as possible without causing an over surface breakdown between the leads and foil.

## **23 Dielectric Voltage-Withstand Test Repeated (Optional)**

23.1 Each representative temperature-limited resistor shall be subjected to a repeat dielectric voltage-withstand test in accordance with Dielectric Voltage-Withstand Test, Section 22, after being subjected to the overload tests in Overload Test, Section 21.

## **RATING**

### **24 Details**

24.1 A resistor shall be rated in volts, ohms, and either watts or amperes at a stated temperature.

## **MARKING**

### **25 Details**

25.1 A resistor or its smallest shipping container shall be plainly and permanently marked with the name or trademark of the manufacturer, which may be in code, and with a catalog designation or equivalent. Each fusing-resistor rating shall have a separate catalog number. An electrical rating shall not be included as part of the marking of a fusing resistor except in code.

25.2 If the marking required by 25.1 is provided on the resistor body, it shall be permanent to the extent that it does not deteriorate to illegibility or become detached as a result of handling, aging, or expected functioning or operation of the resistor.

25.3 If a manufacturer produces a component at more than one factory, each finished component shall have a distinctive marking – which may be in code – by means of which it may be identified as the product of a particular factory.