

1. SCHEMATICS.

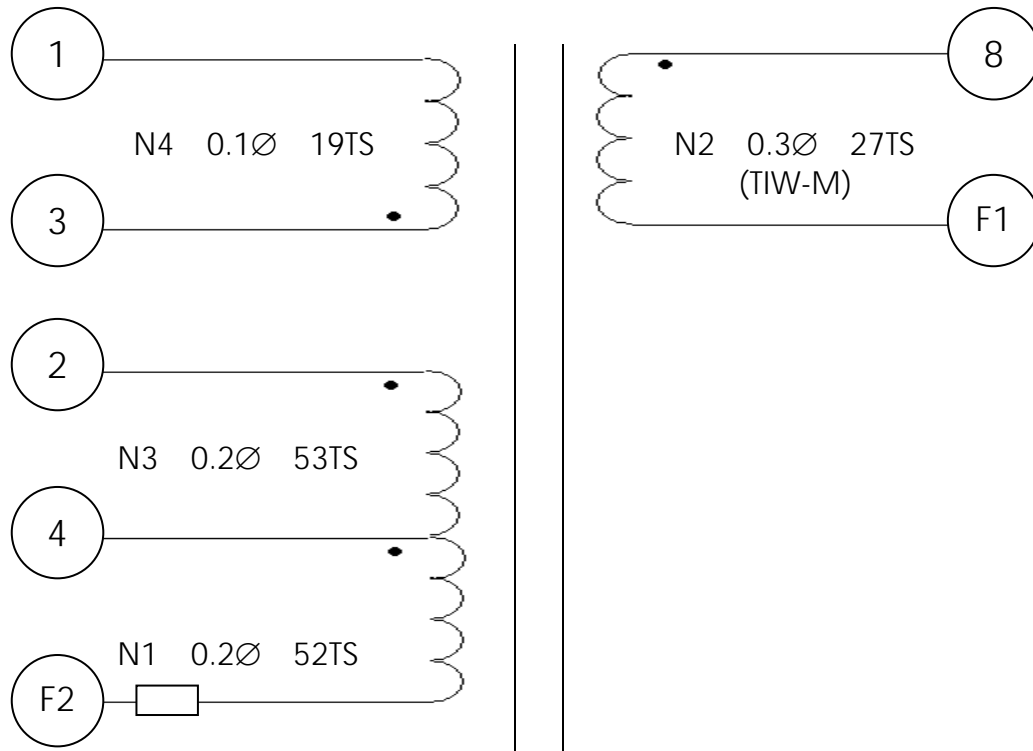

2. WINDING SEQUENCE.

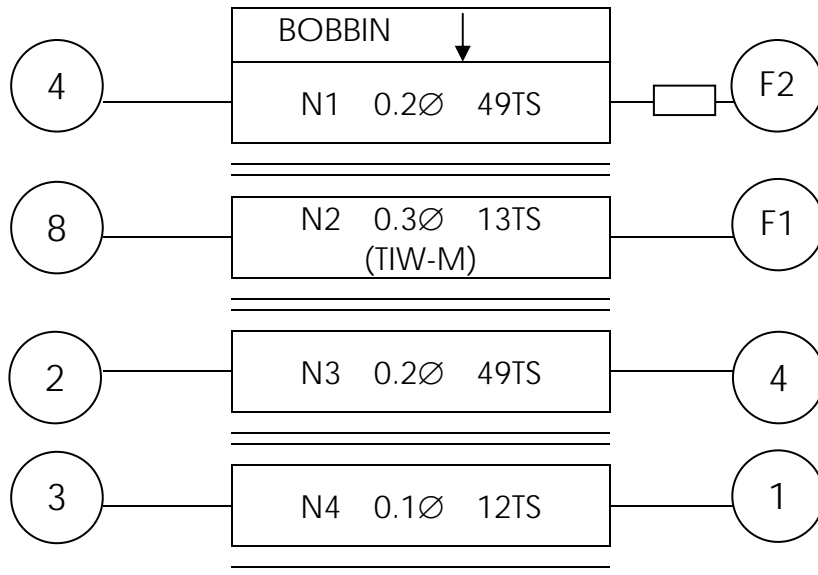

CUSTOMER: 安提亞

PART NO: GU10_5W

DATE: 2010/3/15

REV NO: B

PAGE: 1/3

3. MATERIAL LIST.

NO/ITEM	MATERIAL	MAKER
3-1. CORE	EFD-15 FERRITE CORE. 6H20.V023	FDK.VAKOS
3-2. BOBBIN	EFD-15 TYPE W / 8PIN PHENOLIC / T375J YC-1501	CHANG CHUN PLASTICS CO.,LTD. UL NO.E59481
3-3. WIRE	2UEW / 130°C TIW-M	JUNG SHING WIRE CO.,LTD. UL NO.E174837 COSMOLINK CO.,LTD. UL NO.E258545
3-4. TAPE	POLYESTER TAPE. #1350F-1	3M COMPANY. UL NO.E17385.
3-5. VARNISH	BC-346A.	JOHN C DOLPH CO. UL NO.E317427
3-6. EPOXY	6020H	WELLS ELECTRONIC MATERIAL(GUANGZHOU)CO LTD. UL NO.E229633
3-7. TUBING	PTFE / TFL / 150V.	GREAT HOLDING IND CO.,LTD. UL NO.E156256.

4. ELECTRICAL SPECIFICATION.

- 4-1.INDUCTANCE. P(2-F2) 930~960uH @67KHZ 1V HP-4284A.
 4-2.D.C.RESISTANCE. P(2-F2) 2.15Ω MAX. GOM-801G.
 4-3.HI-POT. PRI TO SEC 1.5KVAC @5mA 2SEC
 SEC TO CORE 1.5KVAC @5mA 2SEC
 PRI TO CORE 1KVAC @5mA 2SEC

CUSTOMER: 安提亞

PART NO: GU10_5W

DATE: 2010/3/15

REV NO: B

PAGE: 2/3

5. CONFIGURATION & DIMENSION. (UNIT:mm)

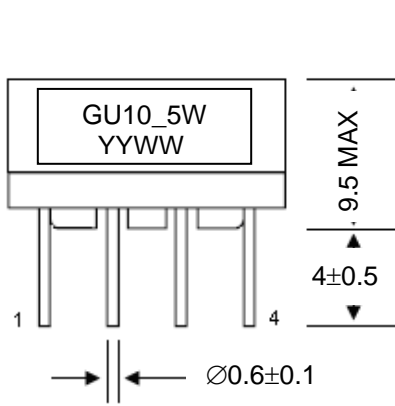

<FRONT VIEW>

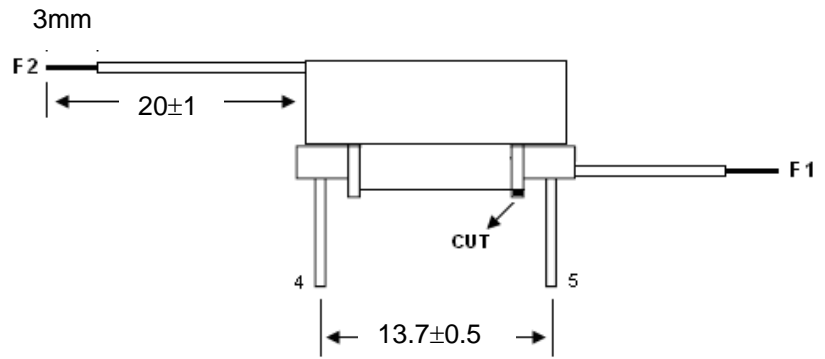

<SIDE VIEW>

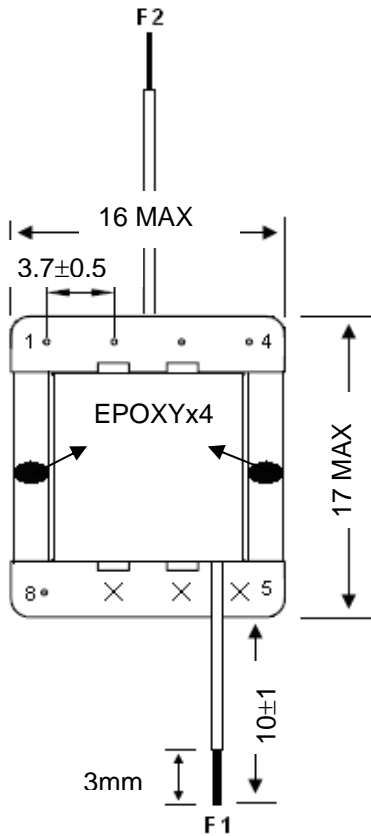

<BOTTOM VIEW>

- PIN 1 朝外繞線
- PIN 4 CUT 1/2
- PIN 5.6.7 CUT OFF
- PIN 5-8 側底部突點超出線包處剪掉
- F1 出線於 PIN5.6 間,長 10mm 含 3mm 鍍錫
- F2 出線於 PIN 1-4 側頂部中間,長 20mm 含 3mm
- 鐵芯接縫處點膠固定
- MARKING: GU10_5W
YYWW

CUSTOMER: 安提亞

PART NO: GU10_5W

DATE: 2010/3/15

REV NO: B

PAGE: 3/3