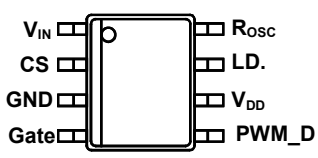
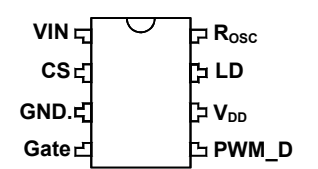

| FEATURES | DESCRIPTION |
|--|---|
| <ul style="list-style-type: none"> ■ > 90% Efficiency ■ Universal rectified 85 – 265V_{AC} input range ■ Constant-current LED driver ■ Applications from a few mA to more than 1A Output ■ LED string from one to hundreds of diodes ■ PWM Low-Frequency Dimming via Enable pin ■ Input Voltage Surge ratings up to 500V ■ Internal thermal overload protection | <p>The SMD802 is a PWM high-efficiency LED driver control IC. It allows efficient operation of High Brightness (HB) LEDs from voltage sources ranging from 85V_{AC} up to 265V_{AC}. The SMD802 controls an external MOSFET at fixed switching frequency up to 300kHz. The frequency can be programmed using a single external resistor. The LED string is driven at constant current rather than constant voltage, thus providing constant light output and enhanced reliability. The output current can be programmed between a few milliamps and up to more than 1.0A.</p> <p>SMD802 uses a rugged high voltage junction isolated process that can withstand an input voltage surge of up to 500V. Output current to an LED string can be programmed to any value between zero and its maximum value by applying an external control voltage at the linear dimming control input of the SMD802. The SMD802 provides a low-frequency PWM dimming input that can accept an external control signal with a duty ratio of 0-100% and a frequency of up to a few kilohertz.</p> |

| APPLICATIONS |
|--|
| <ul style="list-style-type: none"> ■ AC/DC LED Driver applications ■ RGB Backlighting LED Driver ■ Back Lighting of Flat Panel Displays ■ General purpose constant current source ■ Signage and Decorative LED Lighting ■ Chargers |

| PACKAGE/ORDER INFORMATION | |
|--|---|
|  <p style="text-align: center;">8-Pin Plastic S.O.I.C. (Top View)</p> | <p style="text-align: center;">Order Part Number</p> <p style="text-align: center;">SMD802MST</p> |
|  <p style="text-align: center;">8-Pin Plastic DIP (Top View)</p> | <p style="text-align: center;">SMD802M</p> |

PIN FUNCTIONS

| Pin No. | Pin Name | Function |
|---------|------------------|--|
| 1 | V _{IN} | Input voltage |
| 2 | CS | Senses LED string current |
| 3 | GND | Device ground |
| 4 | GATE | Drives the gate of the external MOSFET |
| 5 | PWM_D | Low Frequency PWM Dimming pin, also Enable input. Internal 100kΩ pull-down to GND |
| 6 | V _{DD} | Internally regulated supply voltage. 7.5V nominal. Can supply up to 1 mA for external circuitry. A sufficient storage capacitor is used to provide storage when the rectified AC input is near the zero crossings. |
| 7 | LD | Linear Dimming by changing the current limit threshold at current sense comparator |
| 8 | R _{OSC} | Oscillator control. A resistor connected between this pin and ground sets the PWM frequency. |

ABSOLUTE MAXIMUM RATINGS (Note 1)

| | |
|--|---------------------------------|
| V_{IN} to GND | -0.5V to +520V |
| CS | -0.3V to ($V_{DD} + 0.3V$) |
| LD, PWM_D to GND | -0.3V to ($V_{DD} - 0.3V$) |
| GATE to GND | -0.3V to ($V_{DD} + 0.3V$) |
| V_{DDMAX} | 13.5V |
| Continuous Power Dissipation ($T_A = 25^\circ C$) (Note 1) | |
| 8 Pin DIP (derate 9mW/ $^\circ C$ above $+25^\circ C$) | 900mW |
| 8 Pin SO (derate 6.3mW/ $^\circ C$ above $+25^\circ C$) | 630mW |
| Operating Temperature Range | $-40^\circ C$ to $+85^\circ C$ |
| Junction Temperature | $+125^\circ C$ |
| Storage Temperature Range | $-65^\circ C$ to $+150^\circ C$ |

Note 1: Exceeding these ratings could cause permanent damage to the device. All voltages are with respect to ground. Currents are positive into, negative out of the specified terminal.

BLOCK DIAGRAM

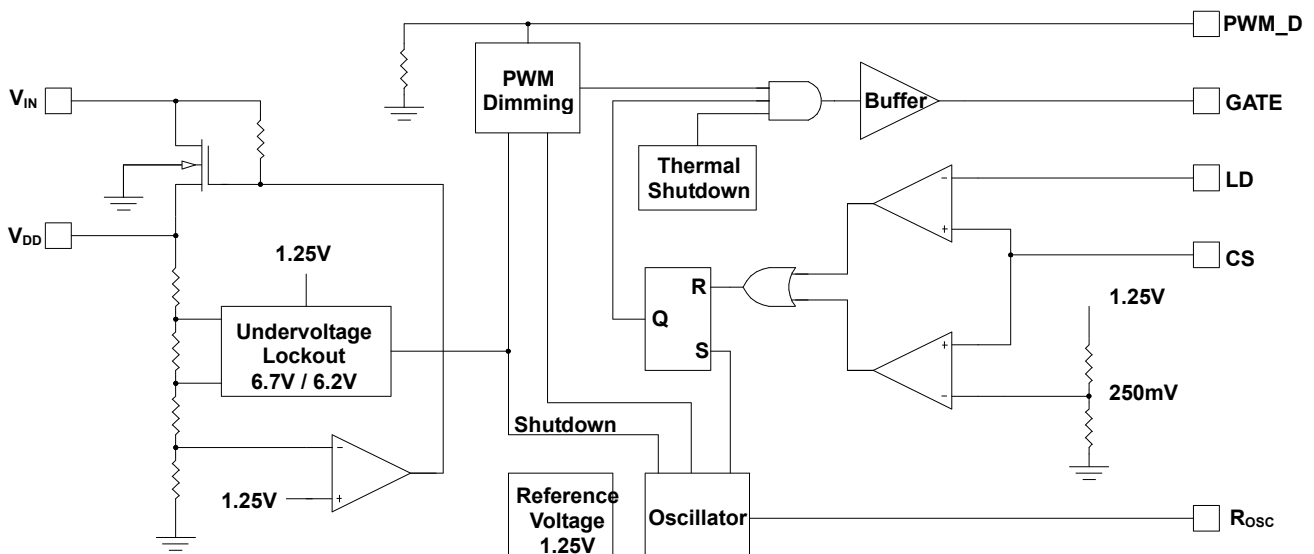

TYPICAL APPLICATIONS

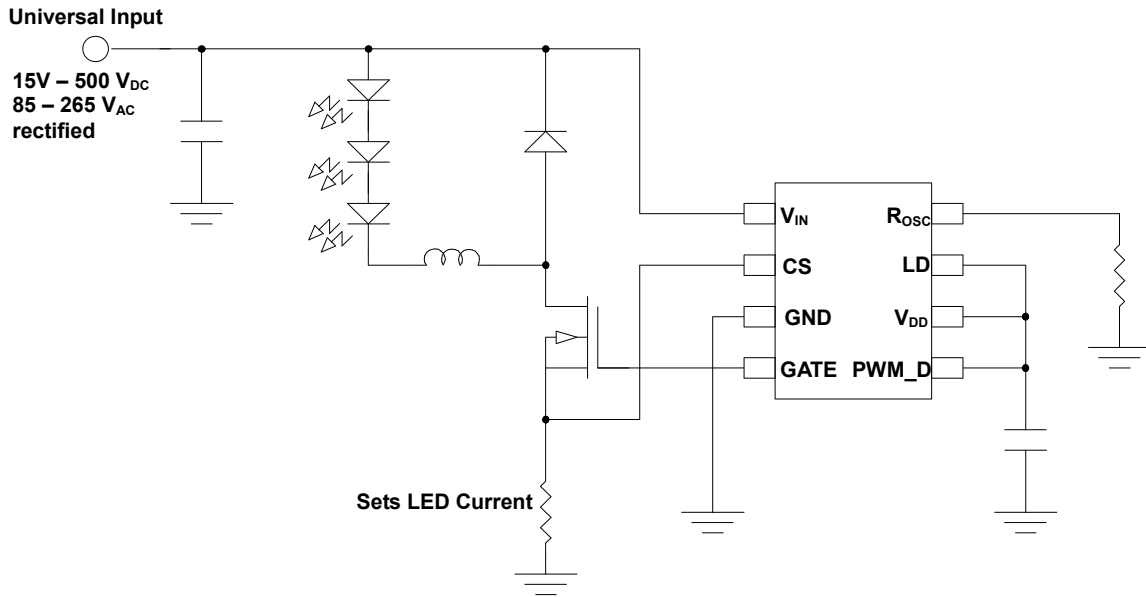

ELECTRICAL CHARACTERISTICS Unless otherwise specified, T_A = 25°C.

| Parameter | Test Conditions | Symbol | Min | Typ | Max | Units |
|---|--|-----------------------|-------------------------|-----|---------------------|-------|
| Input DC supply voltage range | DC input voltage | V _{INDC} | 15.0 | | 500 | V |
| Shut-Down mode supply current | Pin PWM_D to GND, V _{IN} = 15V | I _{INsd} | | 0.5 | 1 | mA |
| Internally regulated voltage | V _{IN} = 15-500V, I _{DD(ext)} =0, pin Gate open | V _{DD} | 7.0 | 7.5 | 8.0 | V |
| Maximal pin Vdd voltage | When an external voltage applied to pin Vdd | V _{DDmax} | | | 13.5 | V |
| V _{DD} current available for external circuitry ¹ | V _{IN} = 15-100V | I _{DD(ext)} | | | 1.0 | mA |
| VDD under voltage lockout threshold | Vin rising | UVLO | 6.45 | 6.7 | 6.95 | V |
| VDD under voltage lockout hysteresis | Vin falling | ΔUVLO | | 500 | | mV |
| Pin PWM_D input low voltage | V _{IN} = 15-500V | V _{EN(lo)} | | | 1.0 | V |
| Pin PWM_D input high voltage | V _{IN} = 15-500V | V _{EN(hi)} | 2.4 | | | V |
| Pin PWM_D pull-down resistance | V _{EN} = 5V | R _{EN} | 50 | 100 | 150 | kΩ |
| Current sense pull-in threshold voltage | @T _A = -40°C to +85°C | V _{CS(hi)} | 225 | 250 | 275 | mV |
| GATE high output voltage | I _{OUT} = 10mA | V _{GATE(hi)} | V _{DD} -0.3 | | V _{DD} | V |
| GATE low output voltage | I _{OUT} = -10mA | V _{GATE(lo)} | 0 | | 0.3 | V |
| Oscillator frequency | R _{OSC} = 1.00MΩ | f _{OSC} | 20 | 25 | 30 | kHz |
| | R _{OSC} = 226kΩ | | 80 | 100 | 120 | |
| Maximum Oscillator PWM Duty Cycle | F _{PWMhf} = 25kHz, at GATE, CS to GND. | D _{MAXhf} | | | 100 | % |
| Linear Dimming pin voltage range | @T _A = <85°C, Vin = 20V | V _{LD} | 0 | | V _{CS(hi)} | mV |
| Current sense blanking interval | V _{CS} = 0.55V _{LD} , V _{LD} = V _{DD} | T _{BLANK} | 150 | 215 | 280 | ns |
| Delay from CS trip to GATE lo | Vin = 20V, V _{LD} = 0.15, V _{CS} = 0 to 0.22V after T _{BLANK} | t _{DELAY} | | | 300 | ns |
| GATE output rise time | C _{GATE} = 500pF | t _{RISE} | | 30 | 50 | ns |
| GATE output fall time | C _{GATE} = 500pF | t _{FALL} | | 30 | 50 | ns |
| Thermal shut down | | T _{SD} | | 150 | | °C |

PACKAGE DESCRIPTION Dimensions in inches (millimeters) unless otherwise specified

SO 8

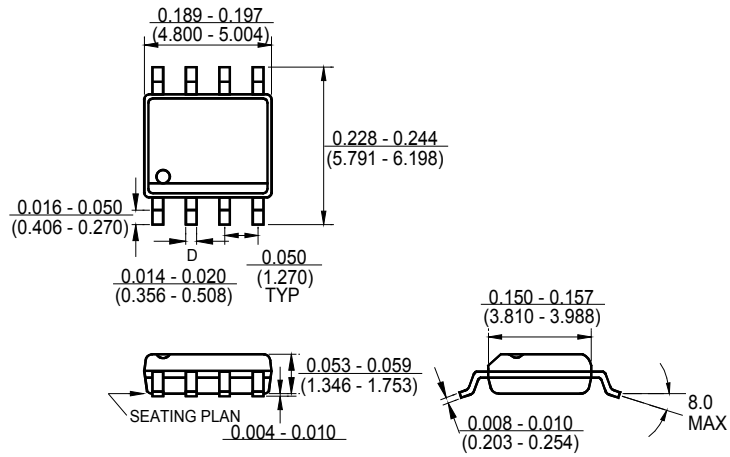

DIP 8

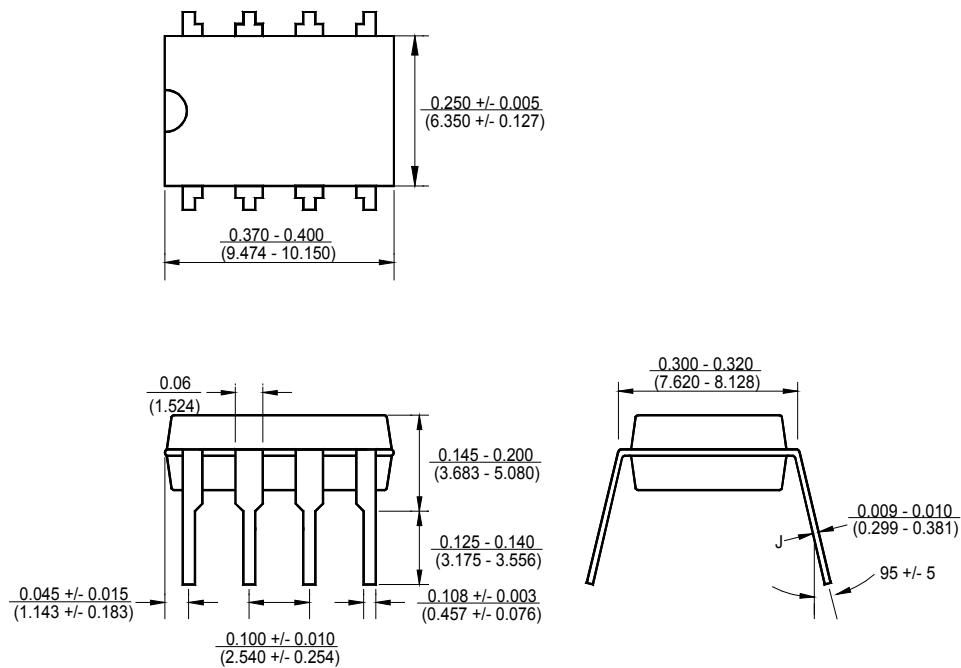

MARKING DIAGRAM

DIP 8

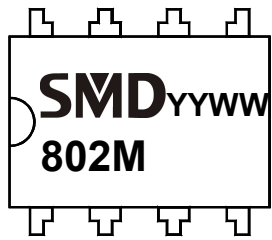

SO 8

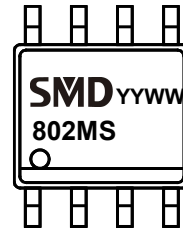

YY = Year, WW = Working Week

IMPORTANT NOTICE

Shamrock Micro Devices (SMD) reserves the right to make changes to its products or to discontinue any integrated circuit product or service without notice, and advises its customers to obtain the latest version of relevant information to verify, before placing orders, that the information being relied on is current.

A few applications using integrated circuit products may involve potential risks of death, personal injury, or severe property or environmental damage. SMD integrated circuit products are not designed, intended, authorized, or warranted to be suitable for use in life-support applications, devices or systems or other critical applications. Use of SMD products in such applications is understood to be fully at the risk of the customer. In order to minimize risks associated with the customer's applications, the customer should provide adequate design and operating safeguards.