

# SSL2102

## Mains LED driver IC for dimmable LED lighting

Rev. 01.00 — 25 June 2009

Product data sheet

### 1. General description

---

The SSL2102 is a Switched Mode Power Supply (SMPS) controller IC that operates in combination with a phase cut dimmer directly from rectified mains. It is designed to drive LED devices. The device includes a high-voltage power switch and a circuit to allow direct start-up from the rectified mains voltage. Furthermore the device includes high-voltage circuitry to supply the phase cut dimmer.

For dimmer applications, integrated dedicated circuitry optimizes the dimming curve.

### 2. Features

---

- Easy migration to existing lighting control infrastructure, TRIAC and transistor dimmers
- Supports majority of available dimming solutions
- Valley switching efficiency is optimized by dedicated built-in circuitry
- Built-in demagnetization detection
- The IC has Over Temperature Protection (OTP) built-in
- Short-Winding Protection (SWP) and Over Current Protection (OCP)
- The IC has internal  $V_{CC}$  generation that allows start-up from rectified mains voltage
- Natural dimming curve by logarithmic correction
- Limited external components required due to high integration level
- Thermal enhanced SO20 wide body package.

### 3. Applications

---

The SSL2102 is suitable for high efficiency and high power factor SSL applications below 25 W, these include:

- SSL retro-fit lamps (e.g. GU10, E27) from 8 W to 15 W.
- LED modules, separate power supplies, e.g. LED spots, down-lights from 15 W to 25 W
- LED strings, e.g. retail display up to a maximum of 25 W

For power ratings below 15 W (for LED modules) and 8 W (for SSL retrofit) NXP offers the SSL2101.

## 4. Quick reference data

**Table 1. Quick reference data**

Symbol	Parameter	Conditions	Min	Typ	Max	Unit
$R_{DSon}$	drain-source on-state resistance	power switch; $I_{SOURCE} = -0.50$ A				
		$T_j = 25$ °C	4.5	6.5	7.5	$\Omega$
		$I_{SOURCE} = -0.20$ A				
		$T_j = 125$ °C	-	9.5	10	$\Omega$
$V_{CC}$	supply voltage		8.5	-	40	V
$f_{osc}$	oscillator frequency		10	100	200	kHz
$I_{DRAIN}$	current on pin DRAIN	$V_{DRAIN} > 60$ V; no auxiliary supply	-	-	2.2	mA
		$V_{DRAIN} > 60$ V; with auxiliary supply	-	30	125	$\mu$ A
$V_{DRAIN}$	voltage on pin DRAIN		40	-	600	V
$\delta_{min}$	minimum duty factor		-	0	-	%
$\delta_{max}$	maximum duty cycle		-	75	-	%
$T_{amb}$	ambient temperature		-40	-	+100	°C

## 5. Ordering information

**Table 2. Ordering information**

Type number	Package		Version
	Name	Description	
SSL2102T	SO20	plastic small outline package; 20 leads; body width 7.5 mm	SOT163-1

### 6. Block diagram

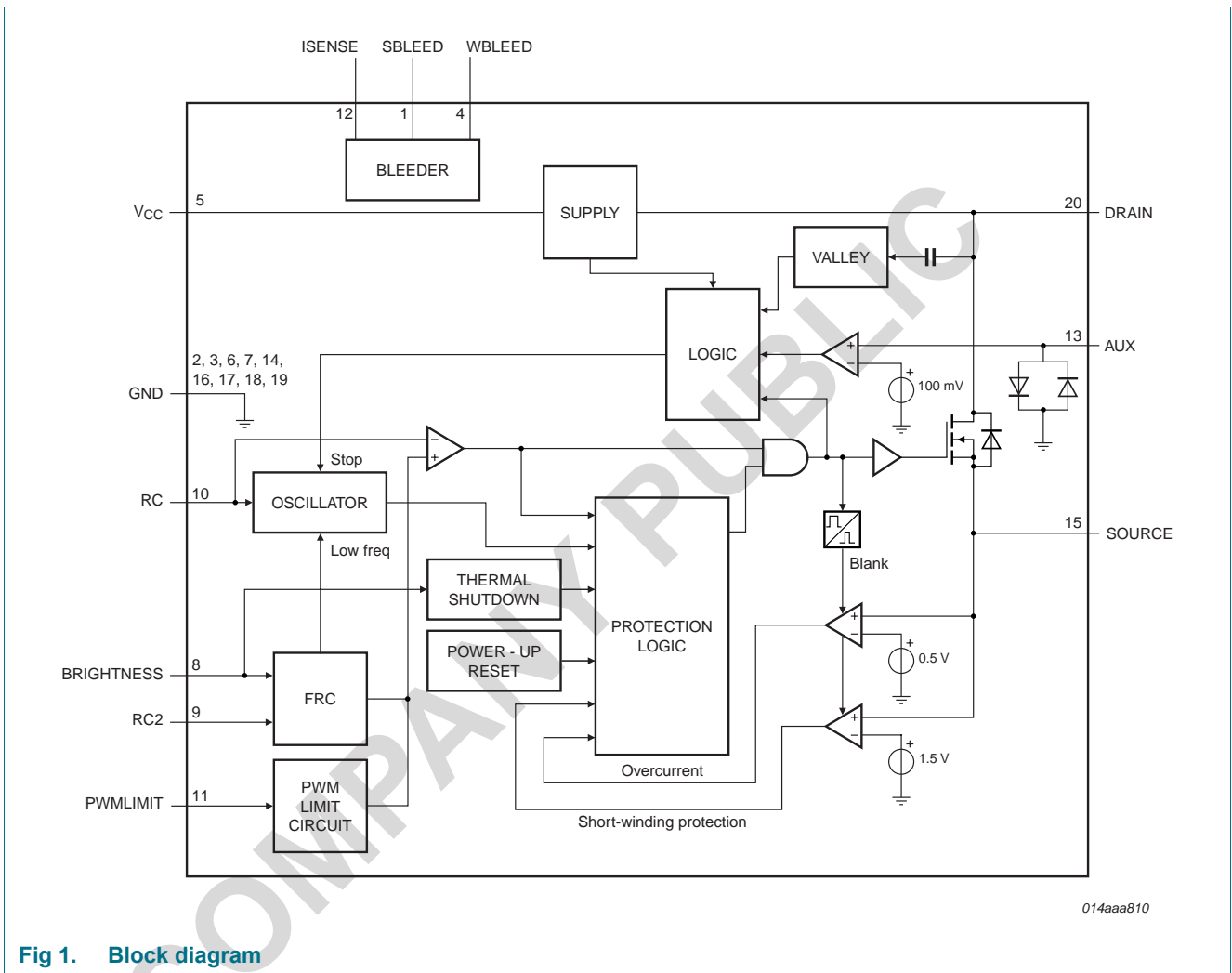
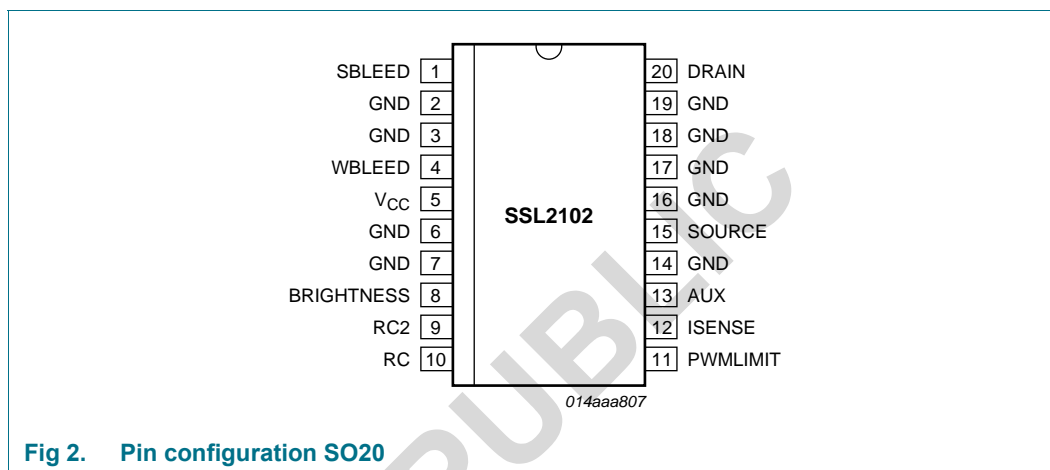

Fig 1. Block diagram

## 7. Pinning information

### 7.1 Pinning



### 7.2 Pin description

**Table 3. Pin description**

Symbol	Pin	Description
SBLEED	1	drain of internal strong bleeder switch
GND	2	ground
GND	3	ground
WBLEED	4	drain of internal weak bleeder switch
V <sub>CC</sub>	5	supply voltage
GND	6	ground
GND	7	ground
BRIGHTNESS	8	brightness input
RC2	9	setting for frequency reduction
RC	10	frequency setting
PWMLIMIT	11	PWM limit input
ISENSE	12	current sense input for WBLEED
AUX	13	Input for voltage from auxiliary winding for timing (demagnetization)
GND	14	ground
SOURCE	15	source of internal power switch
GND	16	ground
GND	17	ground
GND	18	ground
GND	19	ground
DRAIN	20	drain of internal power switch; input for start-up current and valley sensing

## 8. Functional description

The SSL2102 is a LED driver IC that operates directly from the rectified mains.

The SSL2102 uses on-time mode control and frequency control to control the LED brightness. The BRIGHTNESS and PWMLIMIT input of the IC can be used to control the LED light output in combination with an external dimmer. The PWMLIMIT input can also be used for Thermal Lumen Management (TLM) and for precision LED current control.

### 8.1 Start-up and UnderVoltage LockOut (UVLO)

Initially, the IC is self-supplying from the rectified mains voltage. The IC starts switching as soon as the voltage on pin  $V_{CC}$  passes the  $V_{CC(startup)}$  level. The supply can be taken over by the auxiliary winding of the transformer as soon as  $V_{CC}$  is high enough and the supply from the line is stopped for high efficiency operation. Alternatively the IC can be supplied via a bleeder resistor connected to a high voltage.

**Remark:** The maximum  $V_{CC}$  voltage rating of the IC.

If for some reason the auxiliary supply is not sufficient, the high-voltage supply can also supply the IC. As soon as the voltage on pin  $V_{CC}$  drops below the  $V_{CC(UVLO)}$  level, the IC stops switching and will restart from the rectified mains voltage, if the internal current delivered is sufficient.

### 8.2 Oscillator

An internal oscillator inside the IC provides the timing for the switching converter logics.

The frequency of the oscillator is set by the external resistors and the capacitor on pin RC and pin RC2. The external capacitor is charged rapidly to the  $V_{RC(max)}$  level and, starting from a new primary stroke, it discharges to the  $V_{RC(min)}$  level. Because the discharge is exponential, the relative sensitivity of the duty factor to the regulation voltage at low duty factor is almost equal to the sensitivity at high duty factors. This results in a more constant gain over the duty factor range compared to Pulse Width Modulated (PWM) systems with a linear sawtooth oscillator. Stable operation at low duty factors is easily realized. The frequency of the converter when  $V_{BRIGHTNESS}$  is high can be estimated using [Equation 1](#):

$$RC = \frac{1}{3.5} \cdot \left( \frac{1}{f_{osc}} - t_{charge} \right) \quad (1)$$

R equals the parallel resistance of both oscillator resistors. C is the capacitor connected at the RC pin (pin 8).

The BRIGHTNESS input controls the frequency reduction mode. [Figure 3](#) shows that the oscillator switches over from an RC curve with  $R1//R2$  to  $R1$  only. A low BRIGHTNESS voltage will reduce the switching frequency.

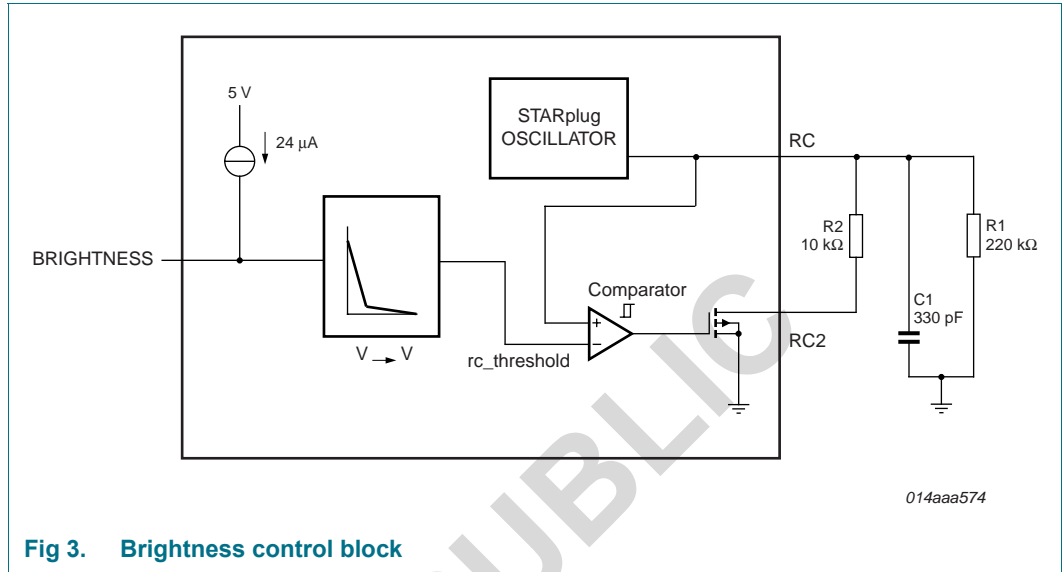

**Fig 3. Brightness control block**

A typical RC waveform is given in [Figure 4](#). The RC switch-over threshold is controlled by the BRIGHTNESS pin.

To ensure that the capacitor can be charged within the charge time, the value of the oscillator capacitor should be limited to 1 nF. Leakage current limits the value of the resistor connected between the RC pin and the ground should be limited to a maximum of 220 kΩ.

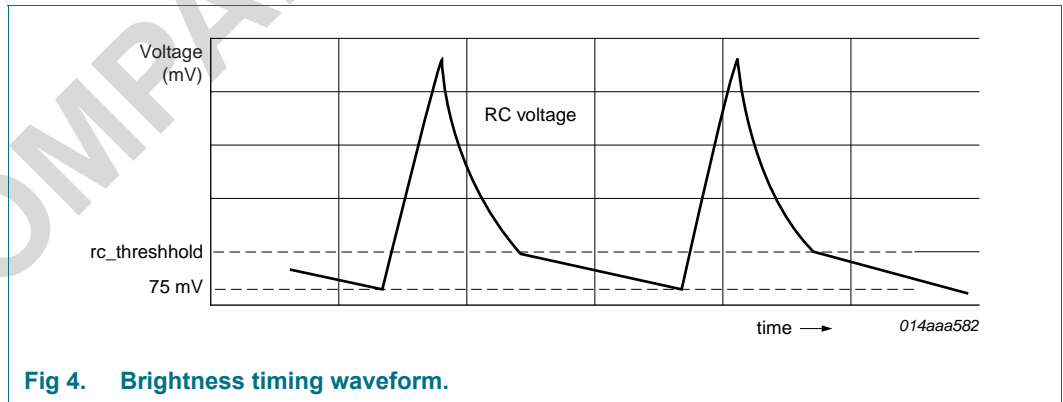

**Fig 4. Brightness timing waveform.**

### 8.3 Duty factor control

The duty factor is controlled by an internally regulated voltage and the oscillator signal on pin RC. The internal regulation voltage is set by the voltage on the PWMLIMIT pin.

A low PWMLIMIT voltage will result in a low on-time for the internal power switch. The minimum duty factor of the switched mode power supply can be set to 0 %. The maximum duty factor is set to 75 %.

### 8.4 Bleeder for dimming applications

The SSL2102 IC contains some circuitry intended for mains dimmer compatibility. This circuit contains two current sinks that are called bleeders. A strong bleeder is used for zero-cross reset of the dimmer and TRIAC latching. A weak bleeder is added to maintain the hold current through the dimmer.

The strong bleeder switch is switched on when the maximum voltage on the WBLEED pin and the SBLEED pin is below the  $V_{th(SBLEED)}$  level (52 V typically). The weak bleeder switch is switched on as soon as the voltage on pin ISENSE exceeds the  $V_{th(high)(ISENSE)}$  level (-100 mV typically). The weak bleeder switch is switched off when the ISENSE voltage drops below the  $V_{th(low)(ISENSE)}$  level (-250 mV typically). The weak bleeder switch is also switched off when the strong bleeder switch is switched on. See [Figure 5](#).

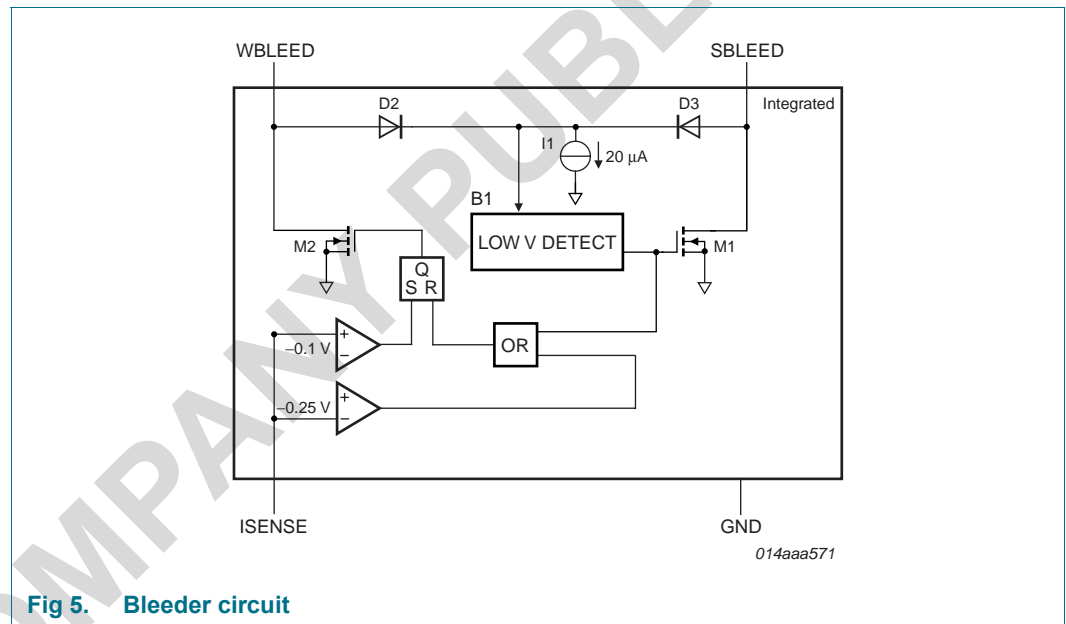

Fig 5. Bleeder circuit

### 8.5 Valley switching

A new cycle is started when the primary switch is switched on (see [Figure 6](#)). After a time determined by the oscillator voltage, RC and the internal regulation level, the switch is turned off and the secondary stroke starts. The internal regulation level is determined by the voltage on pin PWMLIMIT.

After the secondary stroke, the drain voltage shows an oscillation with a frequency of approximately:

$$f = \frac{1}{2 \times \pi \times \sqrt{L_p \times C_p}} \tag{2}$$

where:

$L_p$  = primary self inductance

$C_p$  = parasitic capacitance on drain node

As soon as the oscillator voltage is high again and the secondary stroke has ended, the circuit waits for a low drain voltage before starting a new primary stroke.

Figure 6 shows the drain voltage together with the valley signal, the signal indicating the secondary stroke and the RC voltage.

The primary stroke starts some time before the actual valley at low ringing frequencies, and some time after the actual valley at high ringing frequencies.

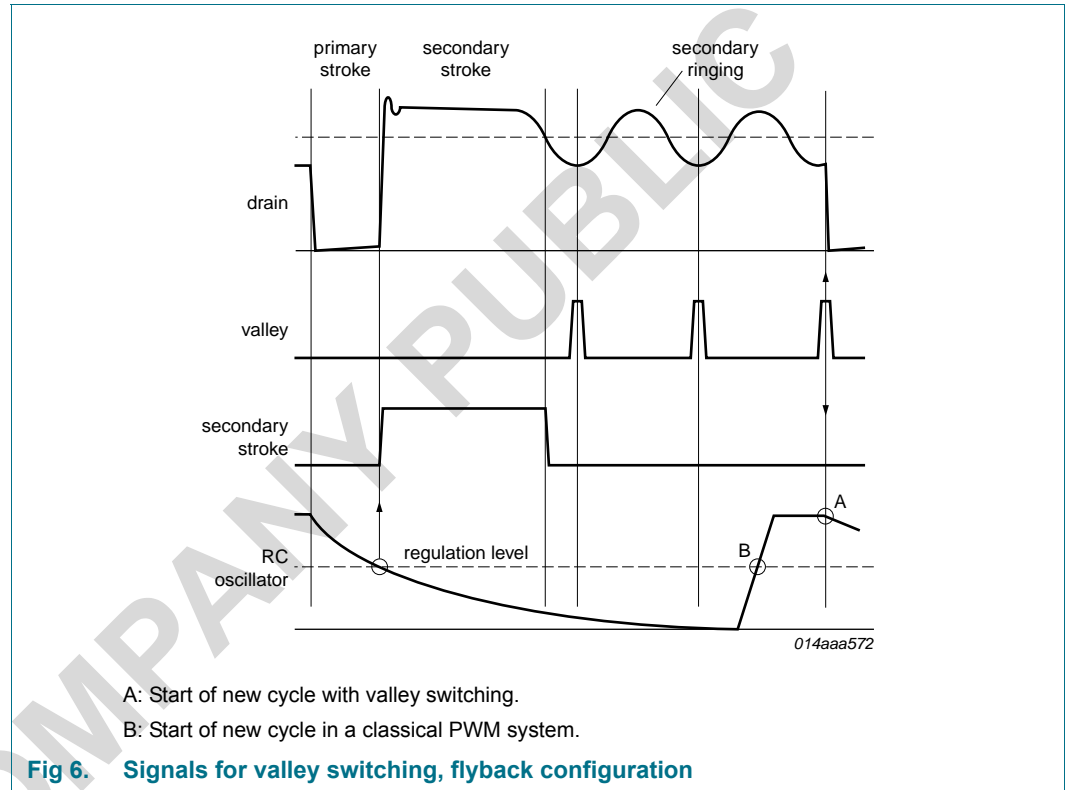
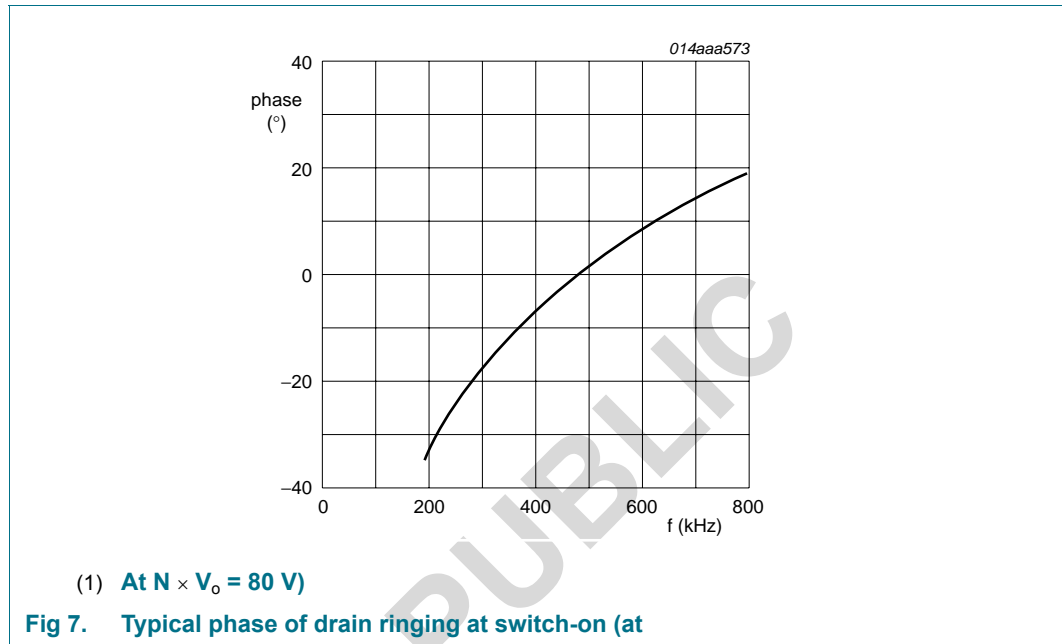

Figure 7 shows a typical curve for a reflected output voltage N at an output voltage of 80 V. This voltage is the output voltage transferred to the primary side of the transformer with the factor N (determined by the turns ratio of the transformer). It shows that the system switches exactly at minimum drain voltage for ringing frequencies of 480 kHz, thus reducing the switch-on losses to a minimum. At 200 kHz, the next primary stroke is started at 33 ° before the valley. The switch-on losses are still reduced significantly.





## 8.6 Demagnetization

The system operates in discontinuous conduction mode if the AUX pin is connected. As long as the secondary stroke has not ended, the oscillator will not start a new primary stroke. During the first  $t_{\text{sup(xfmr\_ring)}}$  seconds, demagnetization recognition is suppressed. This suppression may be necessary in applications where the transformer has a large leakage inductance and at low output voltages.

## 8.7 Overcurrent protection

The cycle-by-cycle peak drain current limit circuit uses the external source resistor  $R_{\text{SENSE}}^1$  to measure the current. The circuit is activated after the leading edge blanking time  $t_{\text{leb}}$ . The protection circuit limits the source voltage over the  $R_{\text{SENSE}}$  resistor to  $V_{\text{th(ocp)SOURCE}}$  and thus limits the primary peak current.

## 8.8 Short-winding protection

The short-winding protection circuit is also activated after the leading edge blanking time. If the source voltage exceeds the short-winding protection threshold voltage  $V_{\text{th(swp)SOURCE}}$ , the IC stops switching. Only a power-on reset will restart normal operation. The short-winding protection also protects in case of a secondary diode short circuit.

## 8.9 Overtemperature protection

Accurate temperature protection is provided in the device. When the junction temperature exceeds the thermal shut-down temperature, the IC stops switching. During thermal protection, the IC current is lowered to the start-up current. The IC continues normal operation as soon as the overtemperature situation has disappeared.

1.  $R_{\text{SENSE}}$  is the resistor between the SOURCE pin and GND

## 9. Limiting values

**Table 4. Limiting values**

In accordance with the Absolute Maximum Rating System (IEC 60134). All voltages are measured with respect to ground; positive currents flow into the device; pins  $V_{CC}$  and RC cannot be current driven. Pins ISENSE and AUX cannot be voltage driven.

Symbol	Parameter	Conditions	Min	Max	Unit
<b>Voltages</b>					
$V_{CC}$	supply voltage	continuous	-0.4	+40	V
$V_{RC}$	voltage on pin RC		-0.4	+3	V
$V_{RC2}$	voltage on pin RC2		-0.4	+3	V
$V_{BRIGHTNESS}$	voltage on pin BRIGHTNESS		-0.4	+5	V
$V_{PWMLIMIT}$	voltage on pin PWMLIMIT		-0.4	+5	V
$V_{SOURCE}$	voltage on pin SOURCE		-0.4	+5	V
$V_{DRAIN}$	voltage on pin DRAIN	DMOS power transistor; $T_{amb} = 25\text{ °C}$	-0.4	+600	V
$V_{SBLEED}$	voltage on pin SBLEED	off-state; $T_j = 125\text{ °C}$	-0.4	+600	V
		on-state; $V_{VCC} > 8.5\text{ V};$ $T_j < 125\text{ °C}$	-0.4	+16	V
$V_{WBLEED}$	voltage on pin WBLEED	off-state; $T_j < 125\text{ °C}$	-0.4	+600	V
		on-state; $V_{VCC} > 8.5\text{ V};$ $T_j < 125\text{ °C}$	-0.4	+12	V
<b>Currents</b>					
$I_{ISENSE}$	current on pin ISENSE		-20	+5	mA
$I_{AUX}$	current on pin AUX		-10	+5	mA
$I_{SOURCE}$	current on pin SOURCE		-2	+2	A
$I_{DRAIN}$	current on pin DRAIN		-2	+2	A
<b>General</b>					
$P_{tot}$	total power dissipation	$T_{amb} = 70\text{ °C}$	-	1.6	W
$T_{stg}$	storage temperature		-55	+150	°C
$T_{amb}$	ambient temperature		-40	+100	°C
$T_j$	junction temperature		-40	+150	°C

**Table 4. Limiting values ...continued**

In accordance with the Absolute Maximum Rating System (IEC 60134). All voltages are measured with respect to ground; positive currents flow into the device; pins  $V_{CC}$  and RC cannot be current driven. Pins ISENSE and AUX cannot be voltage driven.

Symbol	Parameter	Conditions	Min	Max	Unit	
$V_{ESD}$	electrostatic discharge voltage	human body model;	[1]			
		Pins 20, 1, 4		-1000	+1000	V
		All other pins		-2000	+2000	V
		machine model	[2]	-200	+200	V
	charged device model	[3]	-500	+500	V	

[1] Human body model: equivalent to discharging a 100 pF capacitor through a 1.5 k $\Omega$  series resistor.

[2] Machine model: equivalent to discharging a 200 pF capacitor through a 0.75  $\mu$ H coil and a 10  $\Omega$  series resistor.

[3] Charged device model: equivalent to charging the IC up to 1 kV and the subsequent discharging of each pin down to 0 V over a 1  $\Omega$  resistor.

## 10. Thermal characteristics

The heat sink for SSL2102 applications is provided by the Printed-Circuit Board (PCB) copper. The SSL2102 uses thermal leads (pins 2, 3, 6, 7, 16, 17, 18 and 19) for heat transfer from the die to PCB.

Enhanced thermal lead connection may drastically reduce thermal resistance.

The following equation shows the relationship between the maximum allowable power dissipation P and the thermal resistance from junction to ambient.

$$R_{th(j-a)} = (T_{j(max)} - T_{amb}) / P$$

Where:

$R_{th(j-a)}$  = thermal resistance from junction to ambient

$T_{j(max)}$  = maximum junction temperature

$T_{amb}$  = ambient temperature

P = power dissipation

The thermal resistance as a function of the PCB area (Board: 0.8 mm thickness, 2 layers, Bottom Cu coverage 90 %, Cu thickness 70  $\mu$ m

(390 W/mK), Core material conductivity: 0.5 W/mK, 10 vias dia 0.3 mm) is shown in [Figure 8](#)

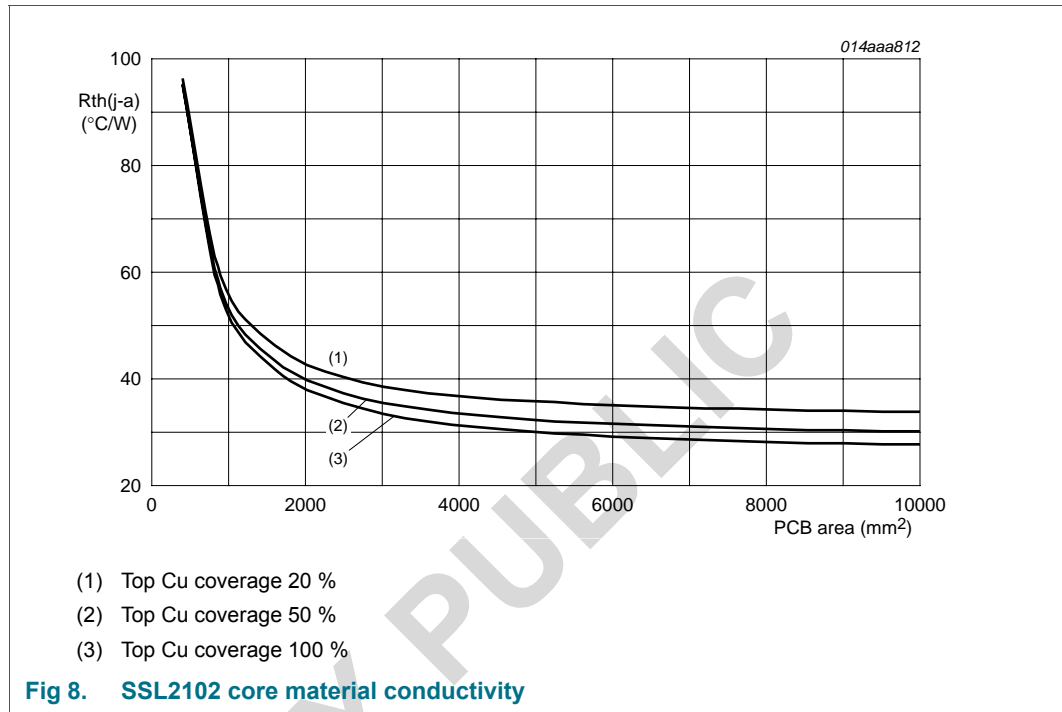

**Table 5: Thermal characteristics**

Symbol	Parameter	Conditions	Typ	Unit
$R_{th(j-a)}$	thermal resistance from junction to ambient		<a href="#">11</a> 62	KW

[1] Measured on a JEDEC test board (standard EIA/JESD 51-3) in free air with natural convection.

## 11. Characteristics

**Table 6. Characteristics**

$T_{amb} = 25\text{ °C}$ ; no overtemperature; all voltages are measured with respect to ground; currents are positive when flowing into the IC and PWMLIMIT and BRIGHTNESS pins are disconnected unless otherwise specified. Typical frequency 100 kHz.

Symbol	Parameter	Conditions	Min	Typ	Max	Unit
<b>Supply</b>						
$I_{CC}$	supply current	normal operation; $V_{DRAIN} = 60\text{ V}$ ; $V_{CC} = 20\text{ V}$	-	1.7	2	mA
$I_{CC(ch)}$	charge supply current	$V_{DRAIN} > 60\text{ V}$ ; $V_{CC} = 0\text{ V}$	-6	-4.5	-	mA
$V_{CC}$	supply voltage		8.5	-	40	V
$V_{CC(startup)}$	start-up supply voltage		9.75	10.25	10.75	V
$V_{CC(UVLO)}$	undervoltage lockout supply voltage		7.9	8.2	8.5	V

**Table 6. Characteristics ...continued**

$T_{amb} = 25\text{ }^{\circ}\text{C}$ ; no overtemperature; all voltages are measured with respect to ground; currents are positive when flowing into the IC and PWMLIMIT and BRIGHTNESS pins are disconnected unless otherwise specified. Typical frequency 100 kHz.

Symbol	Parameter	Conditions	Min	Typ	Max	Unit
$I_{DRAIN}$	current on pin DRAIN	$V_{DRAIN} > 60\text{ V}$ ; no auxiliary supply	-	-	2.2	mA
		$V_{DRAIN} > 60\text{ V}$ ; with auxiliary supply	-	30	125	$\mu\text{A}$
$V_{DRAIN}$	voltage on pin DRAIN		40	-	600	V
<b>Pulse width modulator</b>						
$\delta_{min}$	minimum duty factor		-	0	-	%
$\delta_{max}$	maximum duty cycle	$f = 100\text{ kHz}$	-	75	-	%
<b>SOPS</b>						
$V_{det(demag)}$	demagnetization detection voltage		50	100	150	mV
$t_{sup(xfmr\_ring)}$	transformer ringing suppression time	at start of secondary stroke	1.0	1.5	2.0	$\mu\text{s}$
<b>RC oscillator</b>						
$V_{RC(min)}$	minimum voltage on pin RC		60	75	90	mV
$V_{RC(max)}$	maximum voltage on pin RC		2.4	2.5	2.6	V
$t_{ch(RC)}$	charge time on pin RC		-	1	-	$\mu\text{s}$
$V_{BRIGHTNESS}$	voltage on pin BRIGHTNESS	2.5 V RC2 trip level	-	0.5	-	V
		180 mV RC2 trip level	-	1.25	-	V
		75 mV RC2 trip level	-	2.3	-	V
$f_{osc}$	oscillator frequency		10	100	200	kHz
$I_{BRIGHTNESS}$	current on pin BRIGHTNESS	$V_{BRIGHTNESS} = 0\text{ V}$	-20	-24	-28	$\mu\text{A}$
<b>Bleeder</b>						
$V_{th(SBLEED)}$	threshold voltage on pin SBLEED		46	52	56	V
$V_{th(low)ISENSE}$	low threshold voltage on pin ISENSE		-	-250	-	mV
$V_{th(high)ISENSE}$	high threshold voltage on pin ISENSE		-	-100	-	mV
$R_{DSon(SBLEED)}$	drain-source on-state resistance on pin SBLEED	$I_{SBLEED} = 25\text{ mA}$				
		$T_j = 25\text{ }^{\circ}\text{C}$	140	170	200	$\Omega$
		$T_j = 125\text{ }^{\circ}\text{C}$	220	270	320	$\Omega$

**Table 6. Characteristics ...continued**

$T_{amb} = 25\text{ °C}$ ; no overtemperature; all voltages are measured with respect to ground; currents are positive when flowing into the IC and PWMLIMIT and BRIGHTNESS pins are disconnected unless otherwise specified. Typical frequency 100 kHz.

Symbol	Parameter	Conditions	Min	Typ	Max	Unit
$R_{DSon(WBLEED)}$	drain-source on-state resistance on pin WBLEED	$I_{WBLEED} = 10\text{ mA}$				
		$T_j = 25\text{ °C}$	250	310	350	$\Omega$
		$T_j = 125\text{ °C}$	400	500	600	$\Omega$
<b>Duty factor regulator: pin PWMLIMIT</b>						
$I_{PWMLIMIT}$	current on pin PWMLIMIT		-25	-	-18	$\mu\text{A}$
$V_{PWMLIMIT}$	voltage on pin PWMLIMIT	maximum duty cycle = 3 V	-	3	-	V
		minimum duty factor threshold	-	0.45	-	V
<b>Valley switching</b>						
$(\Delta V/\Delta t)_{vrec}$	valley recognition voltage change with time	minimum absolute value	<a href="#">1</a> -	100	-	V/ $\mu\text{s}$
$f_{ring}$	ringing frequency	$N \times V_O = 100\text{ V}$	200	550	800	kHz
$t_{d(vrec-swon)}$	valley recognition to switch-on delay time		-	150	-	ns
<b>Current and short circuit winding protection</b>						
$V_{th(ocp)SOURCE}$	overcurrent protection threshold voltage on pin SOURCE	$dV/dt = 0.1\text{ V}/\mu\text{s}$	0.47	0.50	0.53	V
$V_{th(swp)SOURCE}$	short-winding protection threshold voltage on pin SOURCE	$dV/dt = 0.1\text{ V}/\mu\text{s}$	-	1.5	-	V
$t_{d(ocp-swoff)}$	delay time from overcurrent protection to switch-off	$dV/dt = 0.5\text{ V}/\mu\text{s}$	-	160	185	ns
$t_{leb}$	leading edge blanking time		250	350	450	ns
<b>FET output stage</b>						
$I_{L(DRAIN)}$	leakage current on pin DRAIN	$V_{DRAIN} = 600\text{ V}$	-	-	125	$\mu\text{A}$
$V_{BR(DRAIN)}$	breakdown voltage on pin DRAIN	$T_{amb} = 25\text{ °C}$	600	-	-	V
$R_{DSon}$	drain-source on-state resistance	power switch; $I_{SOURCE} = -0.50\text{ A}$				
		$T_j = 25\text{ °C}$	4.50	6.5	7.5	$\Omega$
		$I_{SOURCE} = -0.20\text{ A}$				
		$T_j = 125\text{ °C}$	-	9.5	-	$\Omega$

**Table 6. Characteristics ...continued**

$T_{amb} = 25\text{ }^{\circ}\text{C}$ ; no overtemperature; all voltages are measured with respect to ground; currents are positive when flowing into the IC and PWMLIMIT and BRIGHTNESS pins are disconnected unless otherwise specified. Typical frequency 100 kHz.

Symbol	Parameter	Conditions	Min	Typ	Max	Unit
$t_{f(DRAIN)}$	fall time on pin DRAIN	input voltage: 300 V; no external capacitor at drain	-	75	-	ns

**Temperature protection**

$T_{otp}$	overtemperature protection trip	junction temperature	150	160	170	$^{\circ}\text{C}$
$T_{otp(hys)}$	overtemperature protection trip hysteresis	junction temperature	-	2	-	$^{\circ}\text{C}$

[1] Voltage change in time for valley recognition.

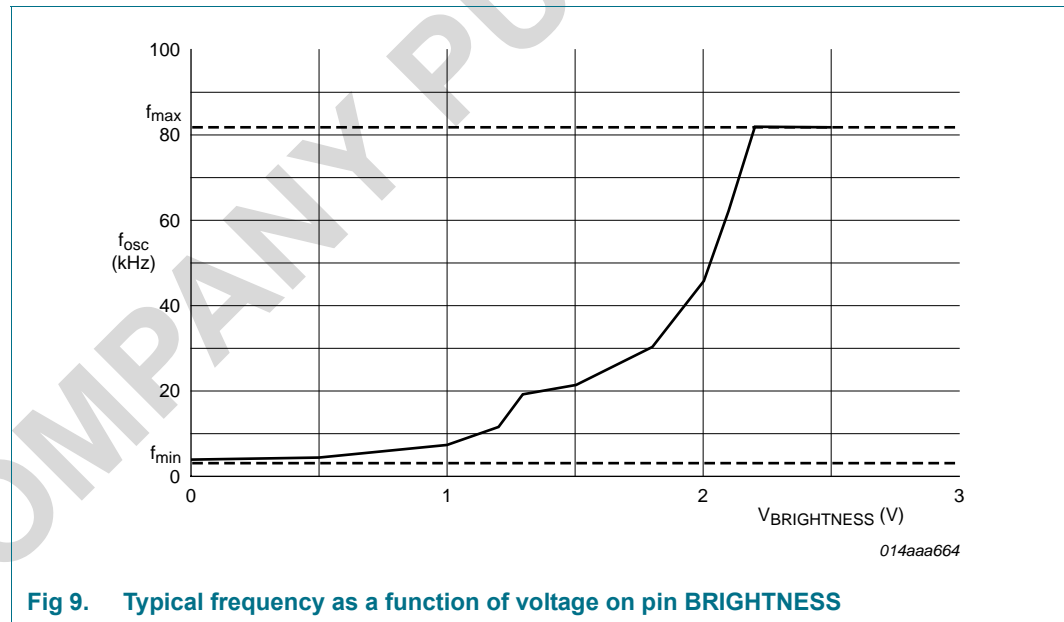

**Fig 9. Typical frequency as a function of voltage on pin BRIGHTNESS**

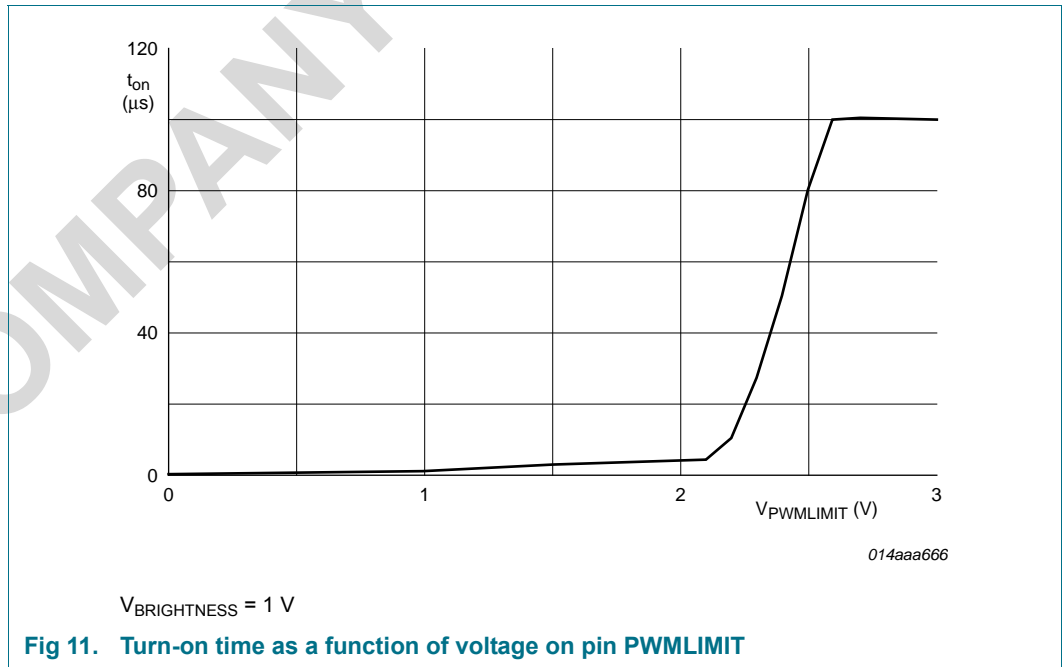
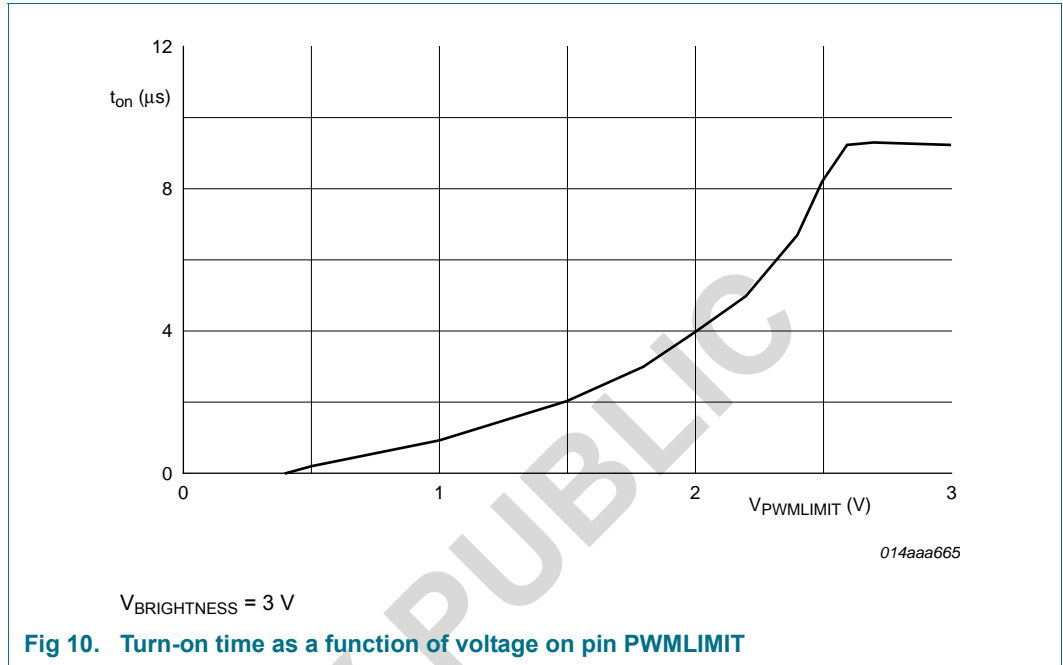



## 12. Application information

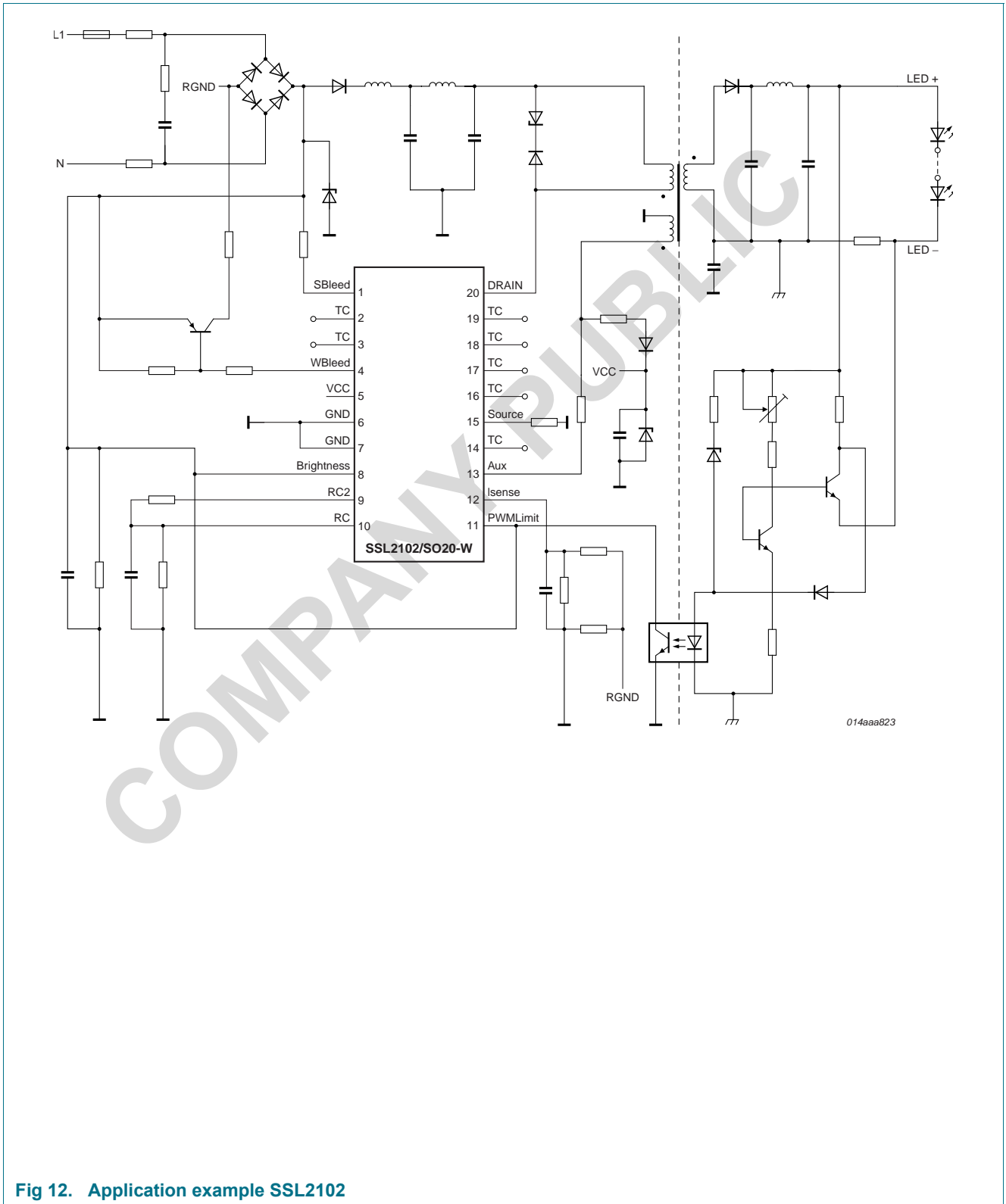

Fig 12. Application example SSL2102

### 13. Package outline

SO20: plastic small outline package; 20 leads; body width 7.5 mm

SOT163-1

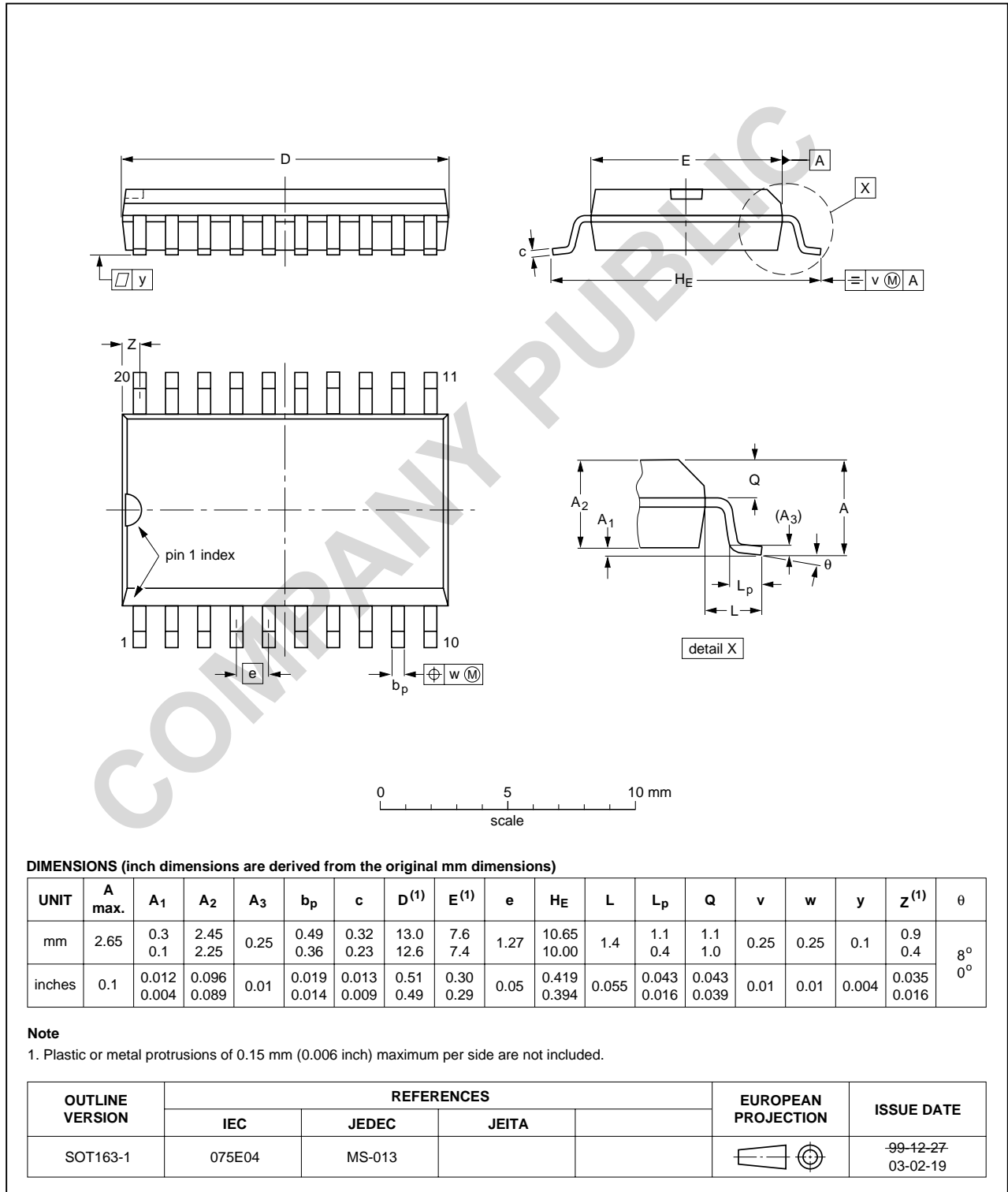

Fig 13. Package outline SOT163-1 (SO20)

## 14. Revision history

Table 7. Revision history

Document ID	Release date	Data sheet status	Change notice	Supersedes
SSL2102_1	20090618	Product data sheet	-	-

COMPANY PUBLIC

## 15. Legal information

### 15.1 Data sheet status

Document status <sup>[1][2]</sup>	Product status <sup>[3]</sup>	Definition
Objective [short] data sheet	Development	This document contains data from the objective specification for product development.
Preliminary [short] data sheet	Qualification	This document contains data from the preliminary specification.
Product [short] data sheet	Production	This document contains the product specification.

[1] Please consult the most recently issued document before initiating or completing a design.

[2] The term 'short data sheet' is explained in section "Definitions".

[3] The product status of device(s) described in this document may have changed since this document was published and may differ in case of multiple devices. The latest product status information is available on the Internet at URL <http://www.nxp.com>.

### 15.2 Definitions

**Draft** — The document is a draft version only. The content is still under internal review and subject to formal approval, which may result in modifications or additions. NXP Semiconductors does not give any representations or warranties as to the accuracy or completeness of information included herein and shall have no liability for the consequences of use of such information.

**Short data sheet** — A short data sheet is an extract from a full data sheet with the same product type number(s) and title. A short data sheet is intended for quick reference only and should not be relied upon to contain detailed and full information. For detailed and full information see the relevant full data sheet, which is available on request via the local NXP Semiconductors sales office. In case of any inconsistency or conflict with the short data sheet, the full data sheet shall prevail.

### 15.3 Disclaimers

**General** — Information in this document is believed to be accurate and reliable. However, NXP Semiconductors does not give any representations or warranties, expressed or implied, as to the accuracy or completeness of such information and shall have no liability for the consequences of use of such information.

**Right to make changes** — NXP Semiconductors reserves the right to make changes to information published in this document, including without limitation specifications and product descriptions, at any time and without notice. This document supersedes and replaces all information supplied prior to the publication hereof.

**Suitability for use** — NXP Semiconductors products are not designed, authorized or warranted to be suitable for use in medical, military, aircraft, space or life support equipment, nor in applications where failure or malfunction of a NXP Semiconductors product can reasonably be expected to result in personal injury, death or severe property or environmental damage. NXP Semiconductors accepts no liability for inclusion and/or use of NXP Semiconductors products in such equipment or applications and therefore such inclusion and/or use is at the customer's own risk.

**Applications** — Applications that are described herein for any of these products are for illustrative purposes only. NXP Semiconductors makes no representation or warranty that such applications will be suitable for the specified use without further testing or modification.

**Limiting values** — Stress above one or more limiting values (as defined in the Absolute Maximum Ratings System of IEC 60134) may cause permanent damage to the device. Limiting values are stress ratings only and operation of the device at these or any other conditions above those given in the Characteristics sections of this document is not implied. Exposure to limiting values for extended periods may affect device reliability.

**Terms and conditions of sale** — NXP Semiconductors products are sold subject to the general terms and conditions of commercial sale, as published at <http://www.nxp.com/profile/terms>, including those pertaining to warranty, intellectual property rights infringement and limitation of liability, unless explicitly otherwise agreed to in writing by NXP Semiconductors. In case of any inconsistency or conflict between information in this document and such terms and conditions, the latter will prevail.

**No offer to sell or license** — Nothing in this document may be interpreted or construed as an offer to sell products that is open for acceptance or the grant, conveyance or implication of any license under any copyrights, patents or other industrial or intellectual property rights.

**Quick reference data** — The Quick reference data is an extract of the product data given in the Limiting values and Characteristics sections of this document, and as such is not complete, exhaustive or legally binding.

**Export control** — This document as well as the item(s) described herein may be subject to export control regulations. Export might require a prior authorization from national authorities.

### 15.4 Trademarks

Notice: All referenced brands, product names, service names and trademarks are the property of their respective owners.

## 16. Contact information

For more information, please visit: <http://www.nxp.com>

For sales office addresses, please send an email to: [salesaddresses@nxp.com](mailto:salesaddresses@nxp.com)

## 17. Contents

<b>1</b>	<b>General description</b> .....	<b>1</b>
<b>2</b>	<b>Features</b> .....	<b>1</b>
<b>3</b>	<b>Applications</b> .....	<b>1</b>
<b>4</b>	<b>Quick reference data</b> .....	<b>2</b>
<b>5</b>	<b>Ordering information</b> .....	<b>2</b>
<b>6</b>	<b>Block diagram</b> .....	<b>3</b>
<b>7</b>	<b>Pinning information</b> .....	<b>4</b>
7.1	Pinning .....	4
7.2	Pin description .....	4
<b>8</b>	<b>Functional description</b> .....	<b>5</b>
8.1	Start-up and UnderVoltage LockOut (UVLO) ..	5
8.2	Oscillator .....	5
8.3	Duty factor control .....	6
8.4	Bleeder for dimming applications .....	7
8.5	Valley switching .....	7
8.6	Demagnetization .....	9
8.7	Overcurrent protection .....	9
8.8	Short-winding protection .....	9
8.9	Overtemperature protection .....	9
<b>9</b>	<b>Limiting values</b> .....	<b>10</b>
<b>10</b>	<b>Thermal characteristics</b> .....	<b>11</b>
<b>11</b>	<b>Characteristics</b> .....	<b>12</b>
<b>12</b>	<b>Application information</b> .....	<b>17</b>
<b>13</b>	<b>Package outline</b> .....	<b>18</b>
<b>14</b>	<b>Revision history</b> .....	<b>19</b>
<b>15</b>	<b>Legal information</b> .....	<b>20</b>
15.1	Data sheet status .....	20
15.2	Definitions .....	20
15.3	Disclaimers .....	20
15.4	Trademarks .....	20
<b>16</b>	<b>Contact information</b> .....	<b>20</b>
<b>17</b>	<b>Contents</b> .....	<b>21</b>

Please be aware that important notices concerning this document and the product(s) described herein, have been included in section 'Legal information'.

© NXP B.V. 2009.

All rights reserved.

For more information, please visit: <http://www.nxp.com>

For sales office addresses, please send an email to: [salesaddresses@nxp.com](mailto:salesaddresses@nxp.com)

Date of release: 25 June 2009

Document identifier: SSL2102\_1

founded by

**PHILIPS**