

Application Note 4145

Electromagnetic Compatibility for Power Converters

Electromagnetic Compatibility (EMC) has become a household name of the past decade. In the mid 1990's, Europe required a reduction on the level of radiated and conducted emission in products that were sold into the region. From that point on many products today have in their design cycle EMC testing.

A common question asked is, what is EMC? EMC is the ability of a device, product, or system to operate properly in its intended electromagnetic environment (presence of EMI), without degradation and without being a source of interference. There are bodies that produce EMC standards that must be followed such as IEC and CISPR.

This application note speaks about EMC regulations dealing with both radiated and conducted emissions. Conducted emissions consist of both common mode and differential mode noise. In order to deal with common and differential mode noise, an AC power main filter is required and a description and example of one is provided. These noises can reside on the power lines entering the unit, but are also produced by internal switching devices.

EMC Regulations

In order to achieve a solid EMC design, one must understand the EMC requirements. The requirements that will follow do not deal with **module** power supplies; rather they deal with system level standards in both Europe and in North America.

The International Electrotechnical Commission (IEC) is responsible for deriving the European requirements, in saying that, the Comite International Special des Perturbations Radioelectriques (CISPR) – International Special Committee on Radio Interference is responsible for the EMC requirements with CISPR 22 defining the strictest limits on conducted emissions. These limits (conducted emissions) are described in the product standards EN 55022 (Figure 1) and EN 55011 (Figure 2). The class A and class B requirements on Figure 1 and Figure 2 refer to the industrial standard and the domestic standard respectively. Depending on the antenna used for detecting the noise, the European standards give two limits. The higher limit for a quasi-peak antenna and a lower limit for an average antenna, but both limits must be met for the equipment to pass the requirement. The FCC standards used in North America have similar specifications to the European EN requirements (see note below Figure 2). Two European standards that are used in testing power supplies are EN 55011 and EN 55022. Figure 3 and Figure 4 show the radiated levels of EN 55011 and the FCC part 15 subpart B (North America) respectively.

In North America, radiated EMI is most often measured in the frequency range from 30 MHz to 10 GHz (according to the FCC), while conducted EMI is most often measured in the frequency range of several kHz to 30 MHz (according to the FCC).

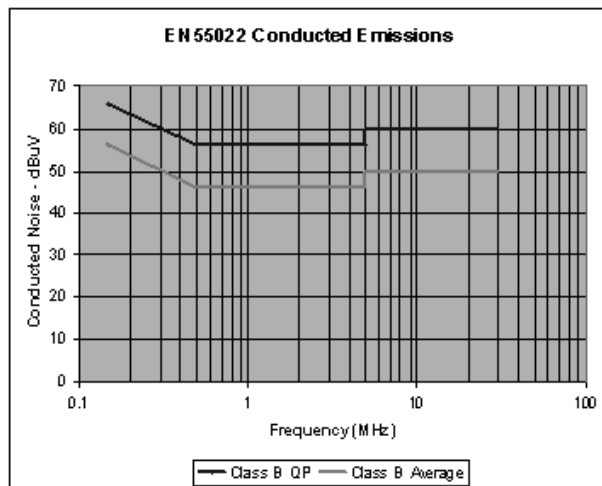

Figure 1. EN 55022 Conducted Emissions

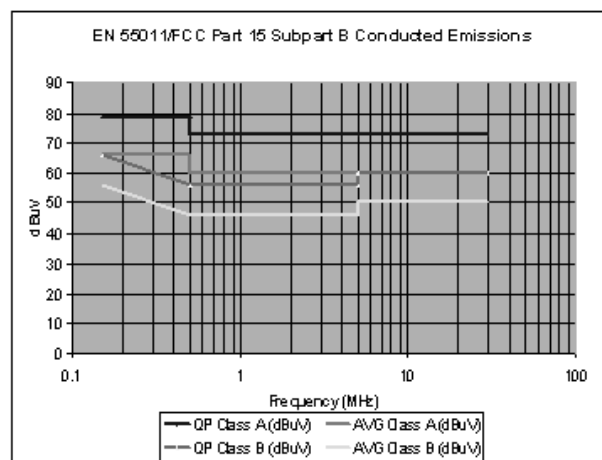

Figure 2. EN55011/FCC Part 15 Subpart B Conducted Levels

Note: After May 23, 2004 the FCC Part 15 Subpart B and the EN 55011 will have the same noise conduction level specification.

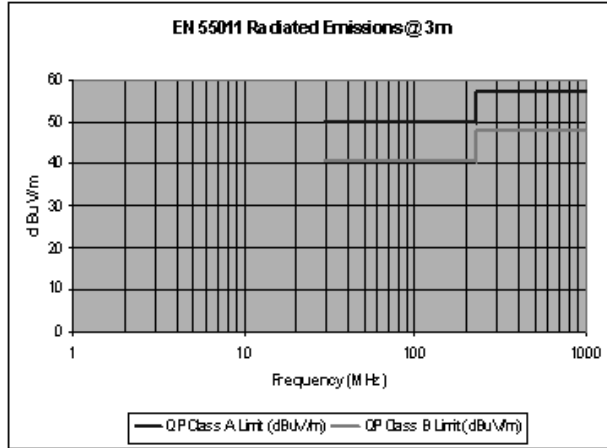

Figure 3. EN 55011 Radiated Emissions at 3 meters

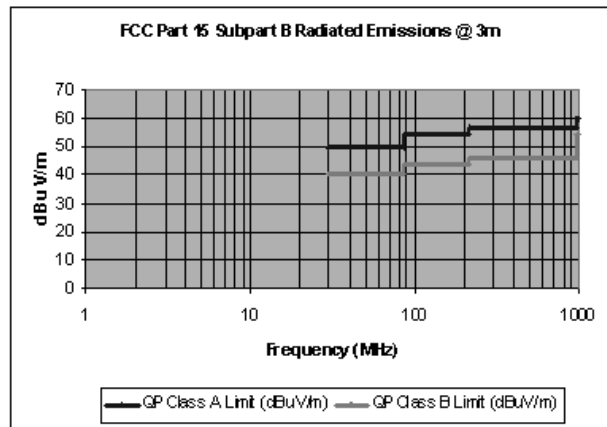

Figure 4. FCC Part 15 Subpart B Radiated Emissions at 3 meters

The goal here is to develop a system that can comply with some or all of the emissions presented above whether it is a stand alone device or incorporated into a larger system.

Common Mode and Differential Mode Noise

There are two major sources of noise, common mode and differential mode. Common mode noise (Figure 5) comes from common mode current. Common mode energy is common to both lines in a single phase system. This energy travels on all the lines, or wires, in the same direction, and this energy is between all these wires and ground. Because the same level is on both wires at the same time, no attenuation is given by any device between the lines.

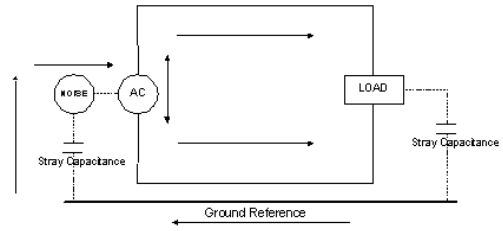

Figure 5. Common Mode Noise

Common mode noise from common mode current always exists on cables entering the device. One way to minimize these currents is to test the cables early on prototype models (this gives the designer the ability to make any changes necessary before the design is finalized for production) and prior to performing EMC compliance testing. In a lot of cases if the device fails the common-mode current test, it will also fail the radiated emission test. The common mode current can be easily measured by using a high frequency clamp on current probe and a spectrum analyzer. A current probe with a response range of up to 250 MHz should be sufficient.

Differential mode noise (Figure 6) is the opposite of common mode noise. This noise is produced by current flowing along either the live or neutral conductor and returning by the other. This produces a noise voltage between the live and neutral conductors.

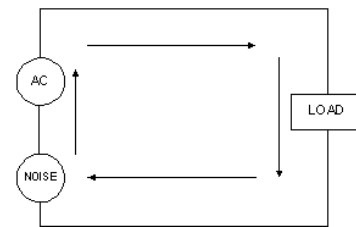

Figure 6. Differential Mode Noise

AC Power Line Main Filter

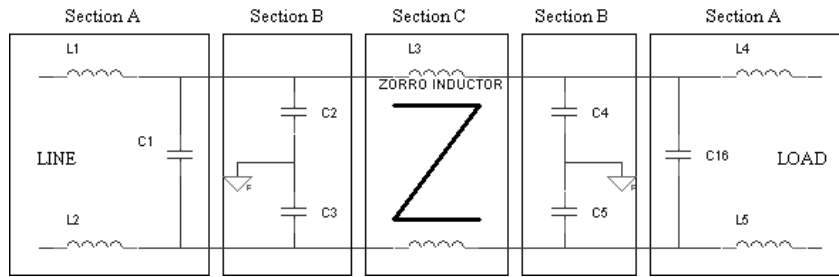

Figure 7. Single Phase AC Line Filter

An example of a single phase AC line filter is shown in Figure 7. Filters of this type are commonly used in reducing both differential and common mode noise from entering and leaving the power supply. The filter in Figure 7 has been broken up into different sections to help better describe its overall function.

Note: Both Section A blocks and Section B blocks perform the same function with the only difference being one is for noise entering the device where the other is used for noise exiting the device.

Blocks

Section A

Inductors L1/L2 and capacitor C1 represent a differential filter for any noise trying to enter the power supply. Differential mode noise is produced by current flowing along either the line or neutral conductor and returning by the other. The combination of L1 and C1 or L2 and C1 represent a voltage divider. Depending on the frequency of the noise, the capacitor C1 represents a smaller impedance (larger load) to the signal thereby reducing any noise on the line. As an example if the impedance of L1 is 10K and the impedance of C1 is 1K at a particular frequency, the noise passing through the filter would be a tenth of its original strength or a reduction of 20dB.

Section B

Capacitors C2 and C3 represent a common mode filter with a reference to ground. Common mode noise manifests itself as a current in phase with the live and neutral conductors and returns via the safety earth. This produces a noise voltage between live/neutral and earth. With all C2, C3, C4, and C5 all being equal, any common mode noise on these lines will be shunted to ground.

Note: Section B is not used in medical equipment due to leakage current.

Section C

Section C of Figure 7 represents the Zorro Inductor (common mode choke) without a reference. The direction of each winding is chosen to give an opposing current flow so any noise present will be cancelled. Magnetic flux caused by

common mode current is accumulated, producing impedance, thereby reducing any noise on the line. Since differential mode has currents running in different directions, magnetic flux caused by differential mode current cancels each other, and impedance is not produced thereby having no effect.

Note: Capacitors C1 and C6 are X Class capacitors, used to reduce differential noise and are tested to withstand mains voltage. X Class capacitors usually run in the 0.01µF to 2µF range. Capacitors C2 through C5 are Y Class capacitors for common mode noise and are tested to ensure that they cannot fail to short circuit (more expensive than X Class). Y Class capacitors are smaller in value usually running between 0.002µF to 0.1µF.

AC Power Line Filter Design Example (AD/DC Flyback Converter)

Design Requirements:

- Transformer turns ratio (a) = 10
- Output Impedance (Zs) = 10Ω (load impedance, worst case for maximum output power)
- Noise reduction required at 20 kHz = 35dB
- Additional headroom for unknown frequency spike = 6dB
- AC Line Frequency (Fl) = 60Hz
- PWM Switching Frequency (Fs) = 100 kHz

To determine the values of the filter, the output load impedance must be recognized. In order to recognize this impedance the output load (worst case) must be reflected back to the primary across the transformer using equation 1.

$$Z_p := a^2 \cdot Z_s \quad \text{Equation 1}$$

$$Z_p = 1 \times 10^3 \Omega$$

where

- Zp = Primary Impedance
- Zs = Secondary Impedance
- a = Transformer Turns Ratio (Np/Ns)

On the input side, the filter will be designed for 10 times the line frequency (keeping the filter transparent to both the line and load), thereby resulting in a frequency of 600Hz. In saying this, the cutoff frequency (Fo) must not be below 600Hz. With a noise reduction of 41dB (35dB plus the 6dB of headroom) at 20 kHz, the designer divides 20 kHz by 2 and subtracts 12dB from 41dB (see Table 1). Initially a single inductor will be used to see if this can be accomplished; if not a second series inductor will be needed. A single inductor will give a drop off of 12dB/octave or 40dB/decade. As shown in Table 1, a single inductor is sufficient for this design with the cutoff frequency (Fo) being 1.25 kHz (above the minimum 600Hz limit).

Table 1. Input Inductor Determination

Frequency (kHz)	dB (Limit of Conducted Emissions)
20	41 (35dB plus 6 dB of headroom)
10	29
5	17
2.5	5
1.25 (Fo)	-7

Now that the cutoff frequency (Fo) is known, the value of the inductor can be created using equation 2.

$$L := \frac{Z_p}{(2 \cdot \pi \cdot F_o)} \quad \text{Equation 2}$$

$$L = 0.127\text{H}$$

where

- L = Differential Inductor
- Zp = Primary Impedance
(reflected back from the secondary)
- Fo = Cutoff Frequency from Table 1

Using Equation 3, one can determine the differential capacitance (Cd) required to complete the differential mode circuit (Section A).

$$Z_p := \sqrt{\frac{L}{C_d}} \quad \text{Equation 3}$$

$$C_d = 6.366 \times 10^{-9}\text{F}$$

where

- L = Differential Inductor
- Zp = Primary Impedance
(reflected back from the secondary)

For a balanced filter (an inductor on both the live and neutral lines), the value is divided by 2, giving 64mH. With the inductance being so large, two inductors will be used to reduce its size. Also an advantage to having more inductors is not only to reduce the inductance, but the Q of the filter decreases, thereby decreasing the risk of oscillations. Table 2 represents a second inductor added to the filter giving a 24dB/octave reduction.

Table 2. Addition of a Second Inductor

Frequency (kHz)	dB (Limit of Conducted Emissions)
20	41 (35dB plus 6 dB of headroom)
10	17
5 (Fnew)	-7

Using Equation 4 and 5 the subsequent new inductor and capacitor values can be computed.

$$L_{\text{new}} := \frac{Z_p}{(2 \cdot \pi \cdot F_{\text{new}})} \quad \text{Equation 4}$$

$$L_{\text{new}} = 0.032\text{H}$$

where

- Lnew = New Differential Inductor
- Zp = Primary Impedance
(reflected back from the secondary)
- Fnew = Cutoff Frequency from Table 2

Again, for a balanced filter (an inductor on both the live and neutral lines), the result is divided by 2, giving 16mH.

$$C_{\text{dnew}} := \frac{L_{\text{new}}}{Z_p^2} \quad \text{Equation 5}$$

$$C_{\text{dnew}} = 3.183 \times 10^{-8}\text{F}$$

where

- Lnew = New Differential Inductor
- Zp = Primary Impedance
(reflected back from the secondary)

The common mode Zorro inductor is the remaining device to be calculated. The Zorro inductor is calculated the same way in which inductor (L) was, but instead of starting off using the cutoff frequency (Fo), one uses the PWM switching frequency (Fs) (see Table 3) and the same dB loss. Since two differential mode inductors are required, two Zorro inductors will be used to complete the filter.

Table 3. Zorro Inductor Calculations

Frequency (kHz)	dB (Limit of Conducted Emissions)
100	41 (35dB plus 6 dB of headroom)
50	17
25 (Foz)	-7

Using Equations 6 and 7, the Zorro inductance (Lzorro) and Zorro capacitance (Czorro) can be found.

$$L_{zorro} := \frac{Z_p}{(2 \cdot \pi \cdot F_{oz})} \quad \text{Equation 6}$$

$$L_{zorro} = 6.366 \times 10^{-3} \text{H}$$

where

- Lzorro = Common Mode Inductor
- Zp = Primary Impedance (reflected back from the secondary)
- Foz = Cutoff Frequency from Table 3

$$C_{zorro} := \frac{L_{zorro}}{Z_p^2} \quad \text{Equation 7}$$

$$C_{zorro} = 6.366 \times 10^{-9} \text{F}$$

where

- Lzorro = Common Mode Inductor
- Zp = Primary Impedance (reflected back from the secondary)

The final design is shown in Figure 8.

If there are problems at the high frequencies, ferrite beads can be added (ferrite beads act as resistors (50 to 200Ω) at low frequencies and inductors at high ones (30MHz)). If differential problems occur, increase the Lnew inductors some, or improve the quality of the Cdnew capacitance, they may have too much leakage at the frequency in question. Common mode problems can be combated by increasing Lzorro inductors.

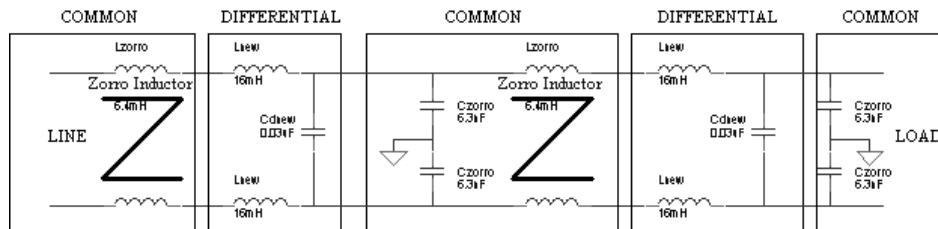

Figure 8. Final Filter Design

Design Guide to Reduce Internal and External In Power Converters

There are three areas of noise generation in an AC to DC power supply:

1. Any noise already present on the AC mains entering the power supply unit (common mode/differential mode)
2. The switching frequency of the power supply (common mode)
3. The fast switching edges and ringing produced when the MOSFET is turned off (common mode)

1) AC Mains

With noisy power main lines, an AC power line filter is used. When using an AC power line filter make sure that it is mounted as close as possible to where the AC power line

enters the printed circuit board (PCB), see Figure 9. Also the ground connection to the filter should be as short as possible with many vias to the ground plane of the primary side of the power supply.

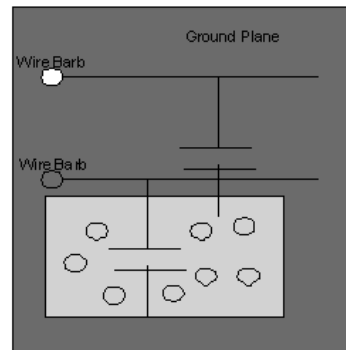

Figure 9. Grounding the Common Mode Capacitors to the Ground Plane

In order to reduce common mode and differential mode noise from leaving and entering the unit, an AC power line filter needs to be used. See section on AC Power Line Main Filter.

2) Switching Frequency of the Power Supply

Just like in a system that uses a system clock, many power supplies have a pulse width modulator (PWM) device that operates at a frequency that is used to control the output voltage. So where a system clock needs to be carefully laid out on a PCB, so does the PWM controller.

In a flyback, forward or other topology design using a transformer, it is important to make the trace from the primary winding to the drain of the switching MOSFET (either internal or external) as wide and short as possible (see Figure 10). This reduces the inductance path thereby keeping the ringing to a minimum. A solid ground plane with a minimal number of holes is preferred to ground both the MOSFET and PWM controller too. There should always be a ground running parallel to the trace for current return (if stray capacitance is not a problem), if there still is a noise issue, one can minimize the drain trace capacitance to the transformer by removing the ground plane from under the trace shown in Figure 10. There are already parasitic capacitors within the MOSFET switch structure that pump current to and from ground. If the ground plane is not removed below the “cross hatched” trace, then additional current will be passed into the ground causing more common mode conducted noise.

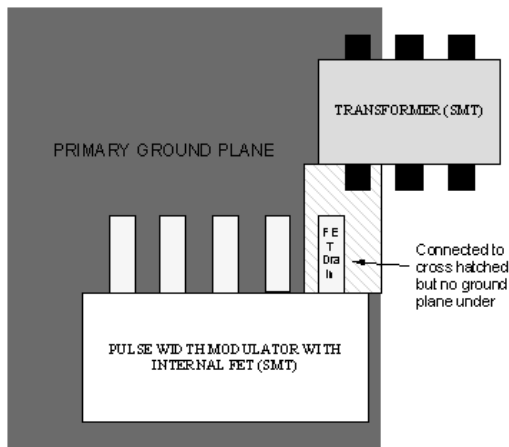

Figure 10. Reducing Drain Trace Capacitance

Note: Especially at higher frequencies, example 500kHz

The source of the MOSFET doing the switching must have a solid connection to the primary side ground plane. In order to accomplish this make a large landing pad for the ground terminal so that a proper number of vias (depending on the sinking current) can be used to make a solid connection to the ground plane, see Figure 11.

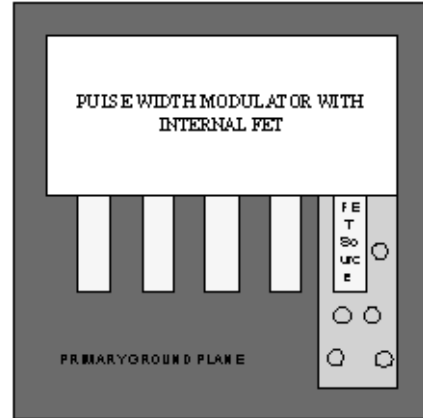

Figure 11. Connecting the Source of an Internal MOSFET to the Ground Plane with a Sufficient Number of Vias

3) PWM Switching Edges and Subsequent Ringing

Figure 12 shows a Resistor Capacitor Diode (RCD) circuitry (R1, C1, and D1) that serves two purposes; firstly C1 slows down the collector voltage rise time (smoothing, reducing radiated EMI) when Q1 is turned off and secondly, it maintains the input voltage to $2V_{CC}$ as not to exceed the breakdown voltage of the switching MOSFET. In making C1 large enough, the rising collector voltage and falling collector current intersect so low down that the transistor dissipation is decreased significantly.

The ringing circuitry (Figure 12 (C2 and R2)) is also important and used to reduce the ringing of the primary side of the transformer caused when the MOSFET relaxes to the input voltage of the power supply, shown below in Figure 13 and Figure 14.

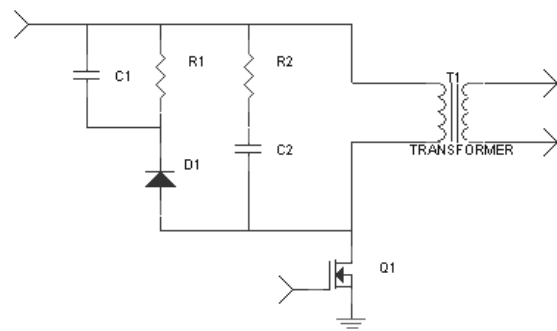

Figure 12. RCD Snubber and RC Ringing Circuitry

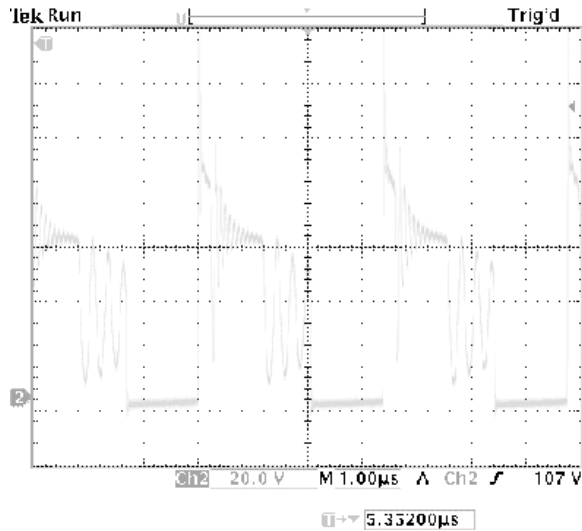

Figure 13. Primary Voltage Waveform Without Ringing Circuitry (C2, R2)

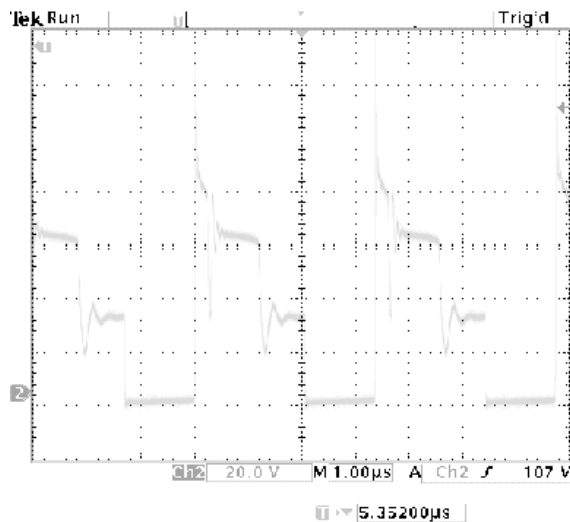

Figure 14. Primary Voltage Waveform with Ringing Circuitry (C2, R2)

As a first pass, one method of determining the values for C2 and R2 is as follows:

1. Determine the frequency of the ringing waveform and calculate the period.
2. Multiply the period, determined in Step 1, by 5.

3. Assume a value for the resistor (usually less than 100R).
4. Calculate the size of the capacitor by dividing the number obtained in Step 2 by the size of the resistor in Step 3.

Note: The advantage of using the resistor R2 and the capacitor C2 network is that it reduces the ringing as shown in Figure 11, but the disadvantage is that the high frequency ripple passing through capacitor C2 gets dissipated as heat in resistor R2. If noise reduction is more important than efficiency then proceed, otherwise efficiency will drop off some.

Printed Circuit Board Guidelines

1. Take the time to place and orient the components properly.
2. If heat sinks are used, make sure they are grounded.
3. A component shield maybe required.
4. Common mode capacitors should have low ESR values as well as maintain a short lead length to the ground place.
5. If a snubber circuit is being used across the transformer to slow down the rise time of the MOSFET switch turning off, make sure that the trace lengths from the drain and two primary transformer pins are short. If possible place the snubber circuitry between the two primary pins.
6. avoid slots in the ground and power (if used) planes
7. Under 50 MHz (don't forget to consider the harmonics of the PWM controller) traditional decoupling methods are effective. Use one or two decoupling capacitors (often 0.1 or 0.01 μF) placed close to the IC power and ground pins. Consider the loop area formed between the decoupling capacitor and the IC, and place the capacitor for minimum loop area.
8. Keep ground runs as short as possible and as thick and large as possible.
9. Avoid sharp corners on traces.
10. Try to group all noisy component in the same area just in case shielding is required.
11. Use multi-layer printed circuit board if possible.

Safety Dealing with Medical Equipment

Common mode noise is a problem for sensitive equipment such as those in the medical field. If a device touches a patient, the total system leakage is limited to 100 μ A. This means that most power supply designers want to restrict this leakage current 20 to 40 μ A. In order to meet this stringent requirement, common mode filters with capacitors to ground are not used. Using common mode chokes, feed through capacitors (high frequency noise is shunted to the chassis ground instead of signal ground) to ground and adding a transformer or isolating the power supply lines into the power supply reduces these common mode conducted emission pulses. Safety standard: IEC950/UL1950 class II is used in medical equipment.

Conclusion

EMC is an important stage of system design today and will become more stringent as time moves on. One must keep in mind that when switching occurs, so does noise whether it be conducted or radiated noise. This application note spoke about board level techniques to reduce noise, if more noise reduction is required, especially on the radiation side, conductive enclosures are an option. There is additional cost with all that is added so as a design engineer, standard compliance, safety compliance, and cost all play an important role in the final product.

References:

EMI Filter Design (1996)
Richard Lee Ozenbaugh

DISCLAIMER

FAIRCHILD SEMICONDUCTOR RESERVES THE RIGHT TO MAKE CHANGES WITHOUT FURTHER NOTICE TO ANY PRODUCTS HEREIN TO IMPROVE RELIABILITY, FUNCTION OR DESIGN. FAIRCHILD DOES NOT ASSUME ANY LIABILITY ARISING OUT OF THE APPLICATION OR USE OF ANY PRODUCT OR CIRCUIT DESCRIBED HEREIN; NEITHER DOES IT CONVEY ANY LICENSE UNDER ITS PATENT RIGHTS, NOR THE RIGHTS OF OTHERS.

LIFE SUPPORT POLICY

FAIRCHILD'S PRODUCTS ARE NOT AUTHORIZED FOR USE AS CRITICAL COMPONENTS IN LIFE SUPPORT DEVICES OR SYSTEMS WITHOUT THE EXPRESS WRITTEN APPROVAL OF THE PRESIDENT OF FAIRCHILD SEMICONDUCTOR CORPORATION. As used herein:

Note: 1. Life support devices or systems are devices or systems which, (a) are intended for surgical implant into the body, or (b) support or sustain life, or (c) whose failure to perform when properly used in accordance with instructions for use provided in the labeling, can be reasonably expected to result in significant injury to the user.

Note: 2. A critical component is any component of a life support device or system whose failure to perform can be reasonably expected to cause the failure of the life support device or system, or to affect its safety or effectiveness.

Note: www.fairchildsemi.com