

TAC9919

Low Cost Green-Power PWM Controller

Features

- Low Cost, Green-Power PWM
- Very Low Start-up Current (about 15 μ A)
- Low Operating Current (about 1.5mA)
- Current Mode Operation
- Under Voltage Lockout (UVLO)
- Built-in Synchronized Slope Compensation
- Programmable PWM Frequency
- High-Voltage CMOS Process with ESD
- SOT-23-6L & DIP-8 Pb-Free Packaging
-

Applications

- Switching AC/DC Adaptor
- Battery Charger
- Open Frame Switching Power Supply
- 384X Replacement

General Description

The TAC9919 is a low cost, low startup current, current mode PWM controller with Green-Power power-saving operation. The integrated functions such as the leading-edge blanking of the current sensing, internal slope compensation and the small SOT-23-6L package provide the users a high efficiency, low external component counts, and low cost solution for AC/DC power applications.

The special Green-Power control is not only to achieve the low power consumption but also to offer a non-audible-noise operation when the TAC9919 is operating under light load or no load condition.

The TAC9919 is designed for the low power adaptor or charger applications. The TAC9919 is with both SOT-23-6L and DIP-8 package.

Pin Assignment

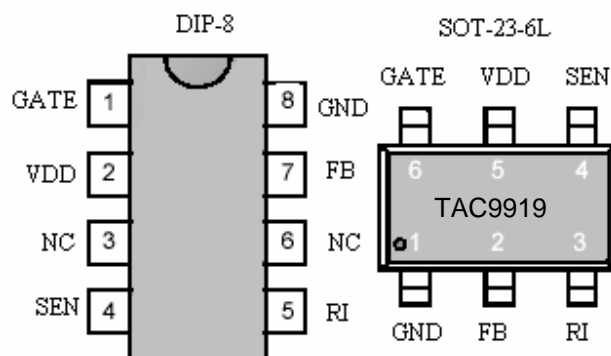

Pin Descriptions

Name	Description
GND	GND Pin
FB	Analog Input. Voltage feedback pin (same as the COMP pin in UC384X),
RI	This pin is to program the switching frequency. By connecting a resistor to ground to set the switching frequency.
SEN	Current sense pin, connect to sense the MOSFET current.
VDD	Supply voltage pin.
GATE	Gate drive output to drive the external MOSFET.

Block Diagram

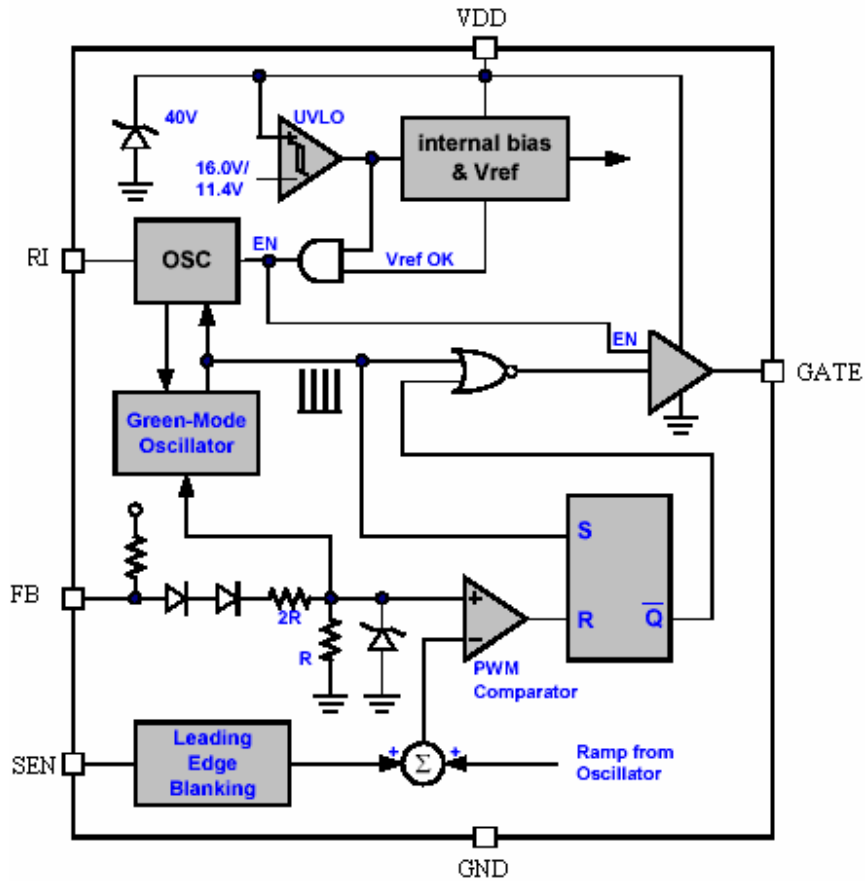

Absolute Maximum Ratings

Symbol	Parameter	Rating	Unit
V_{DD}	Supply voltage Pin Voltage	40	V
V_{FB}	Input Voltage to FB Pin	-0.3 to 6V	V
V_{SEN}	Input Voltage to SEN Pin	-0.3 to 6V	V
P_D	Power Dissipation	300	mW
	ESD Capability, HBM Model	2000	V
	ESD Capability, Machine Model	200	V
T_L	Lead Temperature(Soldering)	SOT-23-6L (20sec)	220
		DIP-8(10sec)	260
T_{STG}	Storage Temperature Range	-55 to + 150	

TAC9919

Electrical Characteristics (Ta=25°C unless otherwise noted, V_{DD} = 15V.)

Symbol	Parameter	Conditions	Min.	Typ.	Max.	Unit
Supply Voltage (V_{DD} Pin)						
I _{ST}	Startup Current	--		15	25	μA
I _{SS}	Operating Current	V _{FB} =0V		1.46	4	mA
		V _{FB} =3V		2		mA
		V _{FB} =Open		0.7		mA
	UVLO(off)	--	10.1	11.1	12.1	V
	UVLO(on)	--	15.1	16.1	16.6	V
Voltage Feedback (FB Pin)						
	Short Circuit Current	V _{FB} =0V		2.8	3.0	mA
	Open Loop Voltage	V _{FB} =Open		4.8		V
	Green Mode Threshold V _{FB}			2.35		V
Current Sensing (SEN Pin)						
	Maximum Input Voltage			1.0	1.05	V
	Delay to Output			175		ns
	Input Impedance			50		KΩ
Oscillator (RI Pin)						
	Frequency	RI=100KΩ	53	58	63	KHz
	Frequency Temp. Stability	-30-85		5.0		%
GATE Drive Output (GATE Pin)						
	Output Low Level	V _{DD} =15V, I _O =20mA			1.5	V
	Output High Level	V _{DD} =15V, I _O =20mA	9			V
	Rising Time	C _L =1000pF		105		ns
	Falling Time	C _L =1000pF		56		ns

Typical Application Circuit

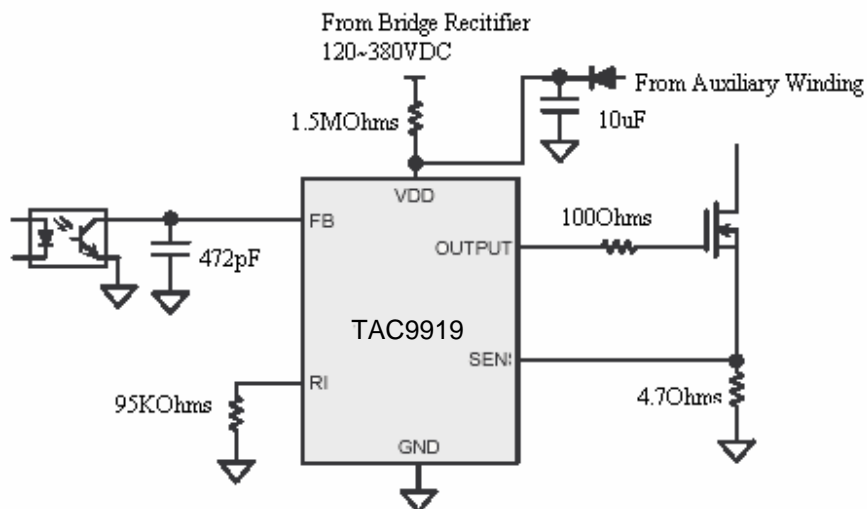

Typical Application Solution

-12V/+12V, 2.5A Power Supply

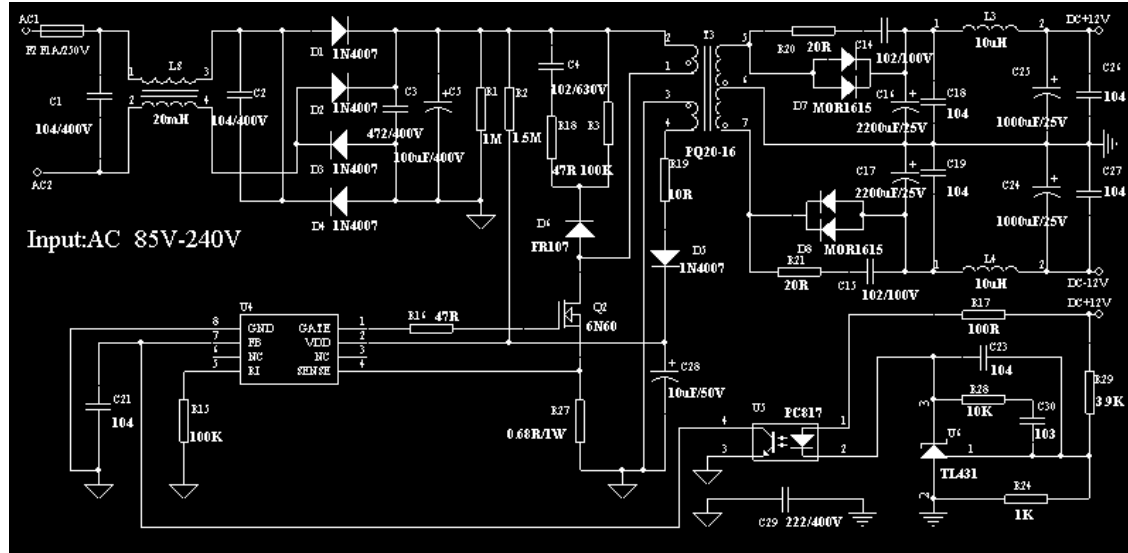

Quantity	Par Number	Description	Quantity	Par Number	Description
2	C1,C2	104/400V	2	R20,R21	20R
1	C3	472/400V	2	R16,R18	47R
1	C4	102/630V	1	R19	10R
2	C14,C15	102/100V	1	R27	0.68r
1	C5	100uF/400V	1	R28	10K
1	C30	103	1	R29	3.9K
8	C18,C19,C20,C21,C27,C26	104	5	D1,D2,D3,D4,D5	1N4007
2	C16,C17	2200uF/25V	1	D6	FR107
2	C24,C25	1000uF/25V	2	D7,D8	MOR1615
1	C28	10uF/50V	1	LS	20mH
1	C29	222/400V	2	L3,L4	10uH
5	R22,R23,R24	1K	1	Q2	2N60
1	R1	1M	1	T3	PQ20-16
1	R2	1.5M	1	F2	F1A/250V
2	R3,R15	100K	1	U4	
1	R17	100R	1	U5	PC817
			1	U6	TL431

12V /3A Power Supply

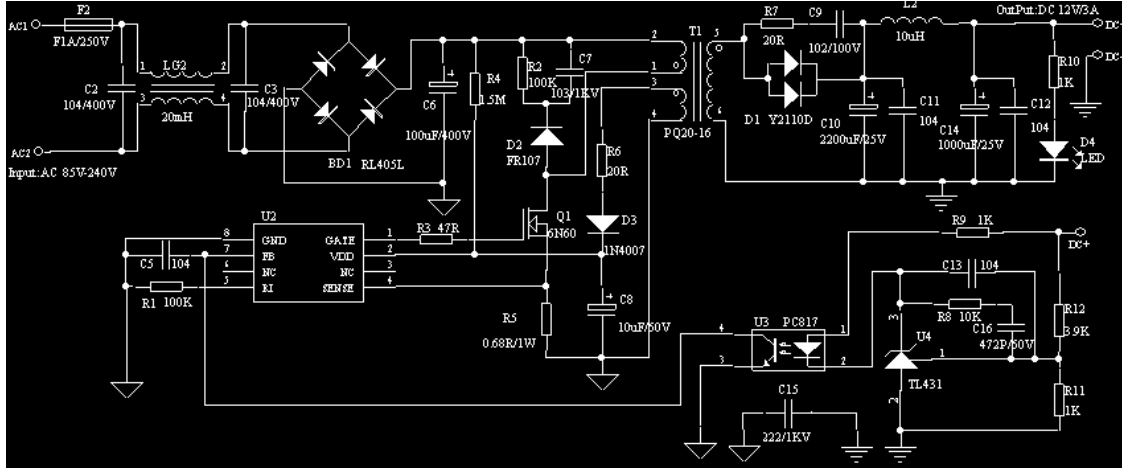

Quantity	Part Number	Description	Quantity	Part Number	Description
2	C2,C3	104/400V	3	R9,R10,R11	1K
4	C5, C11,C12,C13	104	1	R12	3.9K
1	C6	100uF/400V	1	D1	LED
1	C7	103/1KV	1	D2	FR107
1	C8	10uF/50V	1	D3	1N4007
1	C9	102/1KV	1	D4	LED
1	C10	2200uF/25V	1	BD1	RL405L
1	C14	1000uF/25V	1	Q1	2N60
1	C15	222/1KV	1	LG2	20mH
1	C16	472P/50V	1	L2	10uH
2	R1,R2	100K	1	T1	PQ20-16
1	R3	47R	1	F2	F1A/250V
1	R4	1.5M	1	U2	
1	R5	0.68R	1	U3	PC817
2	R6,R7	20R	1	U4	TL431
1	R8	10K			