

Dual QR for AIO PC Power

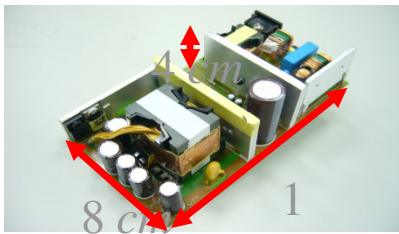

200W demo bd available by Nov.

Efficiency Test Result 180W/12V Adaptor

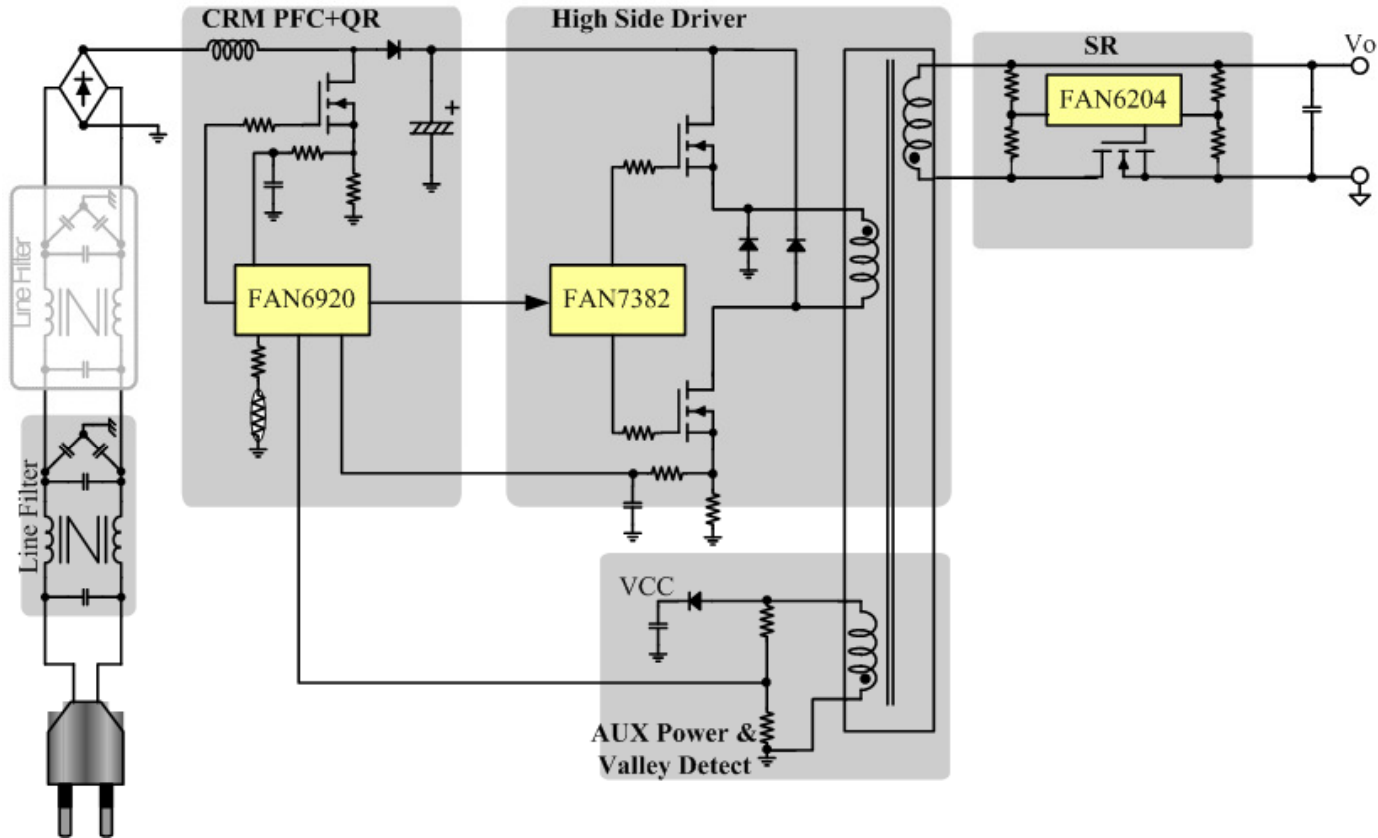
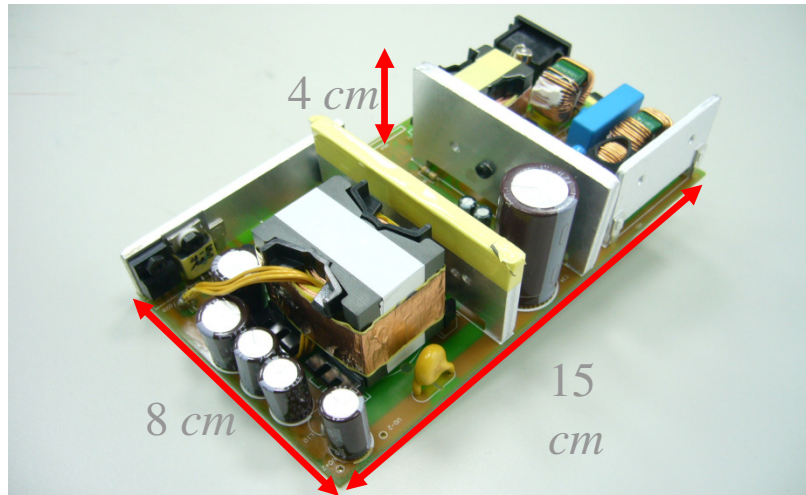

Primary-

PFC Choke: PQ2625

PFC MOSFET: FCPF16N60(SuperFET)

PFC Diode: RHRP1560

Transformer: PQ3535

PWM MOSFET: FDPF18N50(UniFET)

Secondary-

SR: FSR560 (60V/R_{DS-on} 4.7 mΩ)

Schottky: FYPF2006

Efficiency

	25%	50%	100%	Avg
115VAC	90.36%	90.83%	89.32%	90.17%
230VAC	90.20%	90.51%	90.65%	90.45%

180W/12V, Board End

	25%	50%	100%	Avg
115VAC	91.84%	92.62%	92.11%	92.19%
230VAC	93.69%	92.31%	93.28%	93.09%

180W/19V, Board End

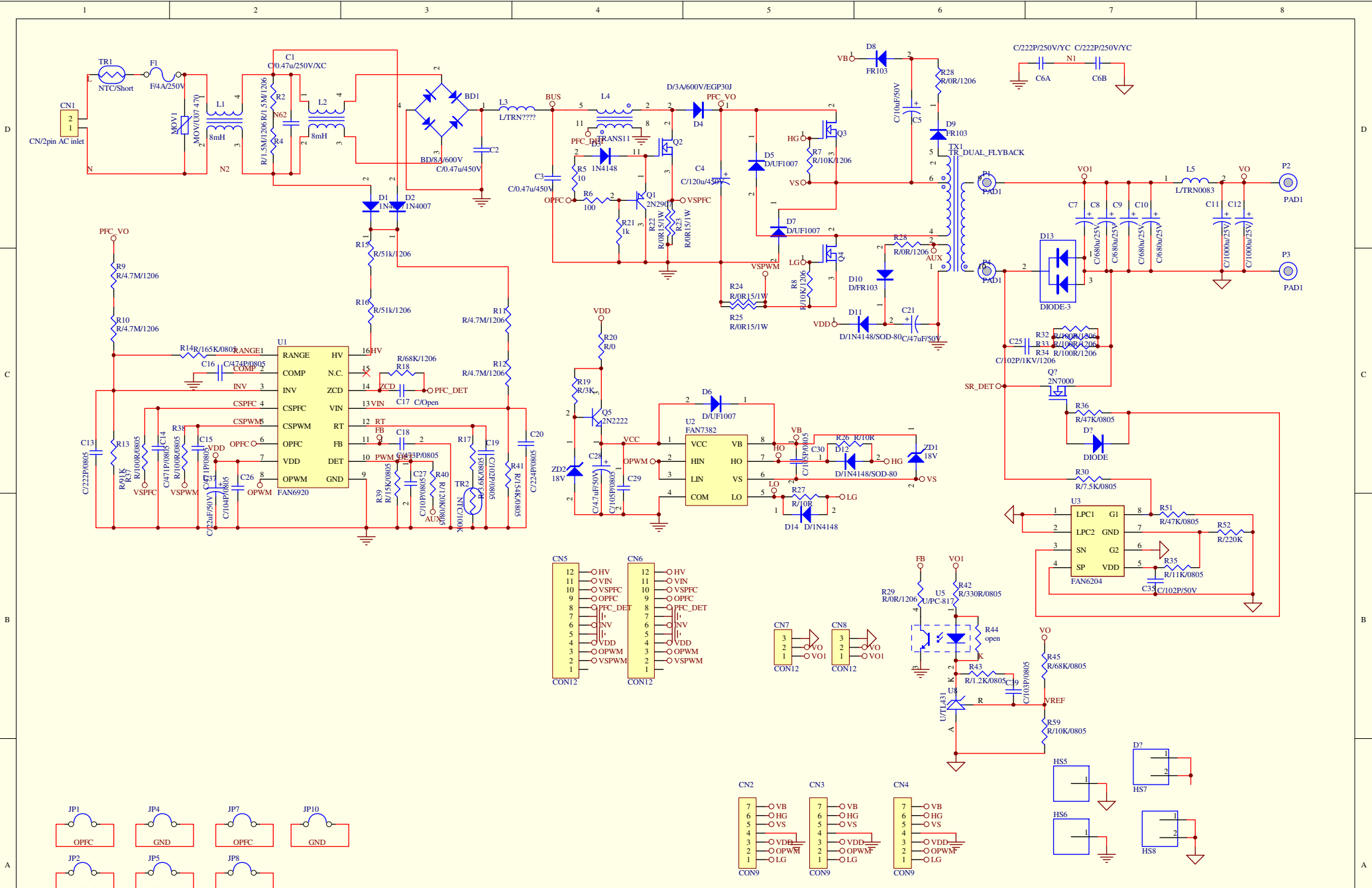

D

C

B

A

D

C

B

A

Title		
Size	Number	Revision
A3		
Date:	25-Aug-2010	Sheet of
File:	C:\Documents and Settings\SLIN\Desktop\20090918.ddb	