

UCC3817 BiCMOS Power Factor Preregulator Evaluation Board

User's Guide

UCC3817 BiCMOS Power Factor Preregulator Evaluation Board

Mike O'Loughlin

Power Supply Control Products

Contents

1	Introduction	1
1.1	Features	2
1.2	Description	2
2	Operating Guidelines	3
2.1	Step 1: Load Connections	4
2.2	Step 2: Applying Input Power	4
2.3	Step 3: Measuring the Evaluation Board's Performance	4
3	Evaluation Board Layouts	4
4	Evaluation Board Components	5
5	Typical Performance	6
6	Additional Information	7

1 Introduction

This user's guide details the Texas Instruments (TI) UCC3817–EVM BiCMOS Power Factor Preregulator Evaluation Module (EVM) SLUU077. It includes a list of EVM features, a brief description of the module illustrated with pictorial and schematic diagrams and EVM specifications.

The UCC3817 evaluation board is designed to illustrate the performance of the controller in a 250 W boost converter with power factor correction. The board is designed to handle a universal input operating voltage range (i.e. 85–265 V ac) with a regulated 385 V dc output.



CAUTION:

- High voltage levels are present on the evaluation board whenever it is energized.
- The output capacitor has high levels of energy storage and it must be discharged before the load is removed. Improper handling of the evaluation board could cause serious injury.
- It is important to maintain the ambient temperature around the evaluation board to below 40°C during operation

1.1 Evaluation Module Features

- Designed for Compliance with IEC 1000-3-2 (Low Total Harmonic Distortion)
- Worldwide Line Operation 85 V_{RMS} to 265 V_{RMS}
- Regulated 385-V, 250-W(max), dc Output
- Accurate Power Limiting
- Accurate Overvoltage Protection

1.2 Description

The UCCx817 provides all the functions necessary for active power-factor-corrected preregulators. The controller achieves near-unity power factor by shaping the ac input-line current waveform to correspond to that of the ac input-line voltage. Average current-mode control maintains stable, low-distortion, sinusoidal line current.

The controller's operation is similar to previously designed Unitrode preregulators with an added feature to reduce the RMS-current in the boost capacitor. The controller uses leading-edge modulation that, when synchronized properly with a downstream dc-to-dc converter, reduces the RMS current in the boost capacitor.

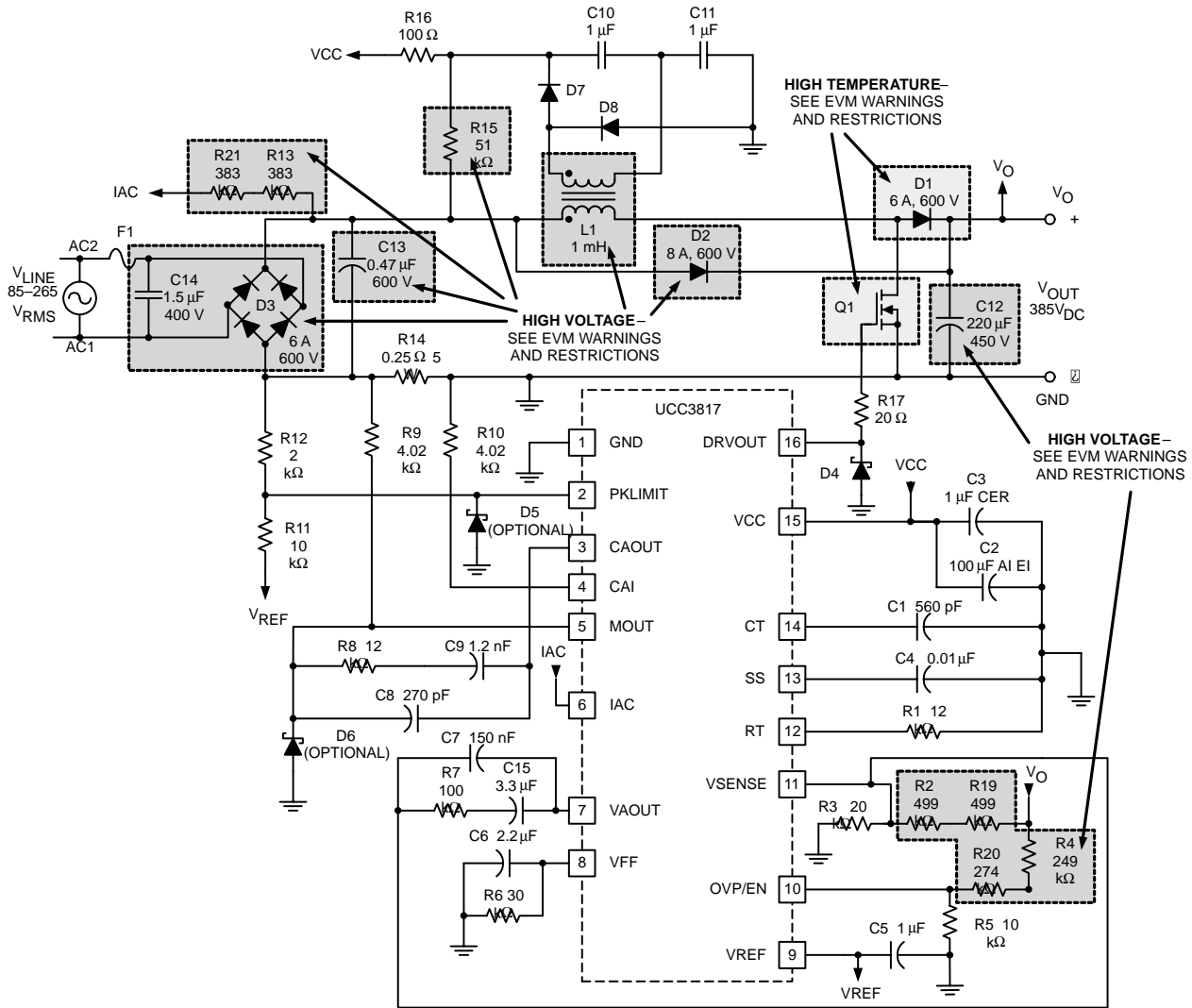

UDG-01001

NOTE: High-Voltage component. See EVM Warnings and Restrictions at the back of this document.
 NOTE: High-Temperature component. See EVM Warnings and Restrictions at the back of this document.

Figure 1. Evaluation Board Schematic

2 Operating Guidelines

The operating guidelines for the evaluation board are provided with reference to the schematic in Figure 1.

NOTE: In order for the output voltage to regulate, a load of 10 W must be applied to the evaluation board's output. In order to maintain power factor near unity, the voltage loop is designed with a slow frequency response. Large transient steps in output current can cause the evaluation module to go out of regulation.

2.1 Step 1. Load Connections

A resistive or electronic load should be applied to the output connections of V_O and GND.

NOTE: For safety reasons the load should be connected before power is supplied to the evaluation board.

2.2 Step 2. Applying Input Power

A 50- or 60-Hz ac power source not exceeding $265 V_{RMS}$ needs be applied across terminals AC1 and AC2 for proper operation.

2.3 Step 3. Measuring the Evaluation Board's Performance

With the ac source set between $85 V_{RMS}$ and $265 V_{RMS}$, the output voltage should be regulated and the input current should track the input-voltage shape with near-unity power factor. The operation of the circuit is verified over the line and load range and shows efficiency in the 90–95% range. At lighter loads, there may be some distortion in the line current due to DCM operation. Please refer to Figure 3 and Figure 4 for typical evaluation board performance.

3 Evaluation Board Layouts

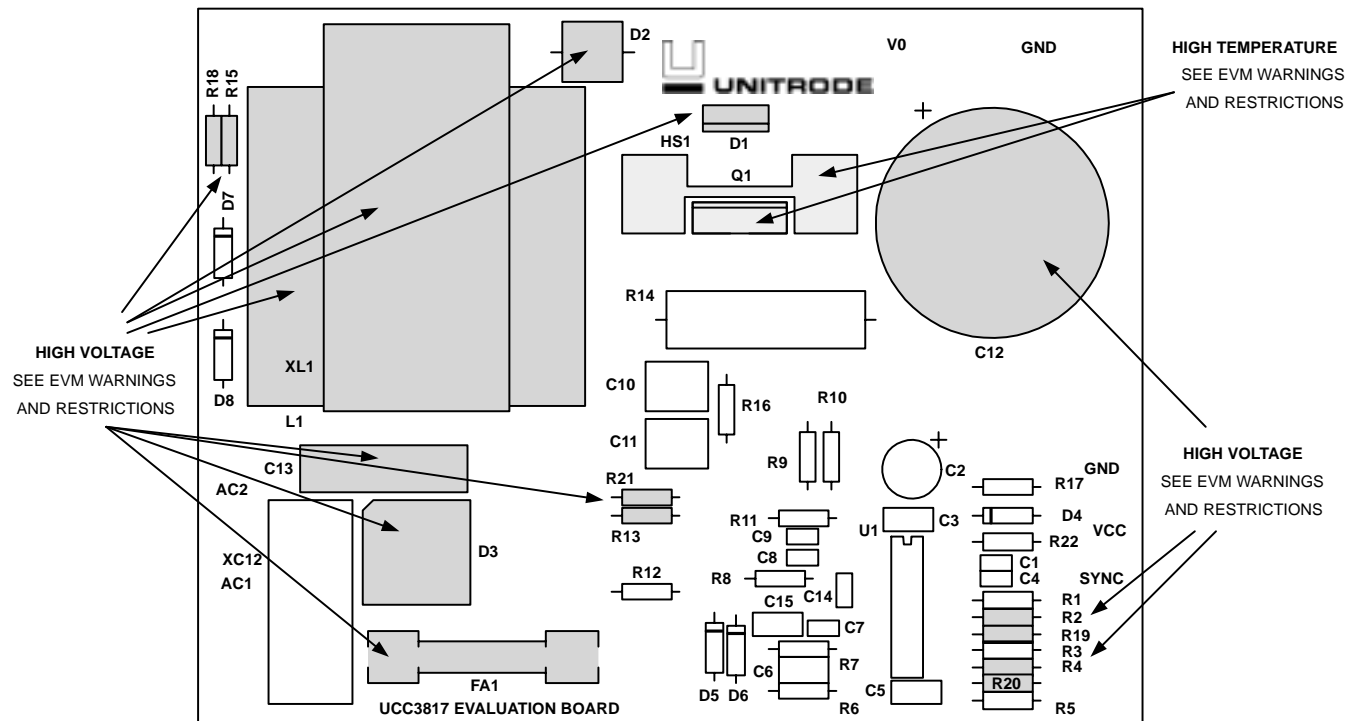

NOTE: High-Voltage component. See EVM Warnings and Restrictions at the back of this document.

NOTE: High-Temperature component. See EVM Warnings and Restrictions at the back of this document.

Figure 2. UCC3817 Evaluation Board Layout Assembly

4 Evaluation Board Components

. Bill of Materials

	Reference	Qty	DESCRIPTION	Manufacturer	Part Number
Capacitors	C1	1	560 pF, 50 V, ceramic	Panasonic	ECU-S1H561JCA
	C2	1	100 μ F, 25 V, electronic	Panasonic	EEU-FC1V101S
	C3, C5	2	1 μ F, 50 V, ceramic	Panasonic	ECU-S1H105MEB
	C4	1	0.01 μ F, 50 V, ceramic	Panasonic	ECU-S1H103KBA
	C6, C15	2	2.2 μ F, 50 V, ceramic	Panasonic	ECU-S1H225MEB
	C7	1	150 nF, 50 V, ceramic, \pm 10%	Panasonic	ECU-S1H154KBB
	C8	1	270 pF, 50 V, ceramic, \pm 10%	Panasonic	ECU-S1H271JCA
	C9	1	1.2 nF, 50 V, ceramic, \pm 10%	Panasonic	ECU-S1H122JCB
	C10, C11	2	1 μ F, 50 V, stacked metal poly	Panasonic	ECQ-V1H105JL
	C12	1	220 μ F, 450 V electronic	Panasonic	ECO-S2WB221DA
	C13	1	0.47 μ F, 600 V (optional for user, not used on EVM)	Panasonic	ECQ-E6474KF
	C14	1	1.5 μ F, 400 V Poly	Panasonic	ECW-F4155JB
	C16	1	Not used	Panasonic	ECU-S2A330JCA
Diodes	D1	1	6 A, 600 V, ultra fast diode	International Rectifier	HFA08TB60
	D2	1	8 A, 600 V, 400 A surge	General Instruments	G1756CT
	D3	1	6 A, 600 V, bridge	General Instruments	PB66
	D4, D5, D7, D8	4	1 A, 40 V, schottky		1N5819
	D6	1	100 mA, 20 V, schottky		BAT85
	D9	1	Not used		
Fuses	F1	1	6 A, 250 V, 3 AG glass fast acting cartridge type		
	FH1, FH2	2	3AG fuse clip		
Heat Sink	HS1	1	Heat sink for Q1	Aavid	513201
	HS2	1	Heat sink for D1	Aavid	579302 B 0 00 00
Inductors	L1	1	1 mH, 5.5 A, 20:1 TR	Cooper Electronic Technologies	CTX08-13679-02
MOSFETs	Q1	1		International Rectifier	IRFP450
Resistors	R1	1	12.1 k Ω , 1/4 W		
	R3	1	20 k Ω		
	R4	1	249 k Ω		
	R5, R11	2	10 k Ω		
	R6	1	30.1 k Ω		
	R7	1	100 k Ω		
	R8	1	12.1 k Ω		
	R9, R10	2	4.02 k Ω		
	R12	1	2 k Ω		
	R13, R21	2	383 k Ω		
	R14	1	0.25 Ω , 3 W		
	R15, R18	2	24 k Ω , 1W, metal oxide/metal film	Panasonic	ERG 1S G 243
	R16	1	100 Ω		

	Reference	Qty	DESCRIPTION	Manufacturer	Part Number
Resistors	R17	1	20 Ω		
	R18	1	24 k Ω , 1W, metal oxide/metal film		ERX 1S G 243
	R2, R19	2	499 k Ω		
	R20	1	274k		
	R22	1	Zero Ohm jumper or 26AWG wire		
Integrated Circuit	U1	1	UCC3817N	Texas Instruments	UCC3817N
Sockets	X @ U1	1	16 pin DIP socket		
Board	PCB	1	UCC3817 BARE PC BOARD		
Hardware	X1 @ Q1	1	Thermal Pad Silicone TO220		
	X2 @ HS1	1	Screw Pan Hd #6–32 X 3/8		
	X3 @ HS1	1	Nut #6X32		

NOTE: Unless otherwise specified, all resistors are 0.25 W metal film with a 1% tolerance.

5 Typical Performance

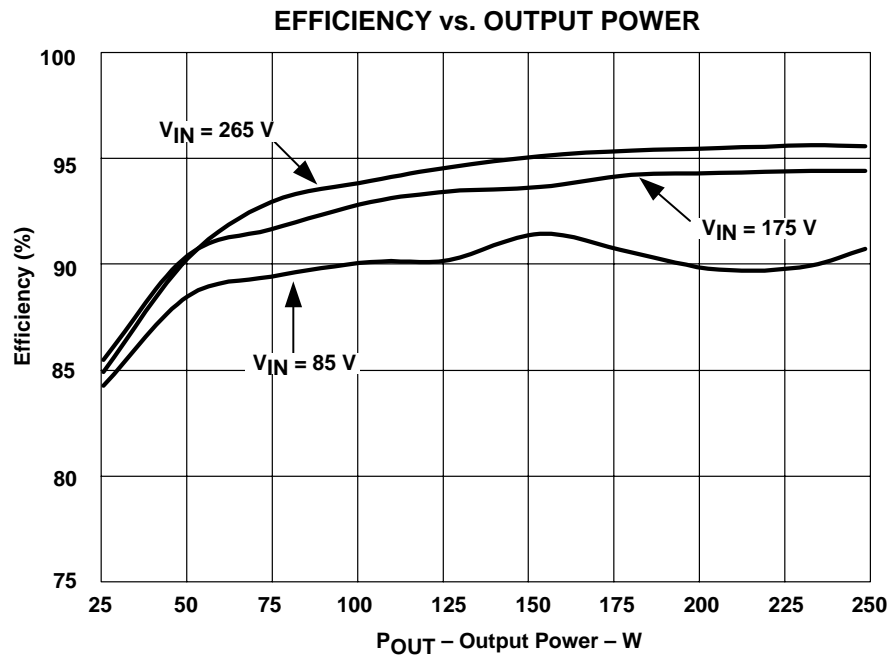

Figure 3.

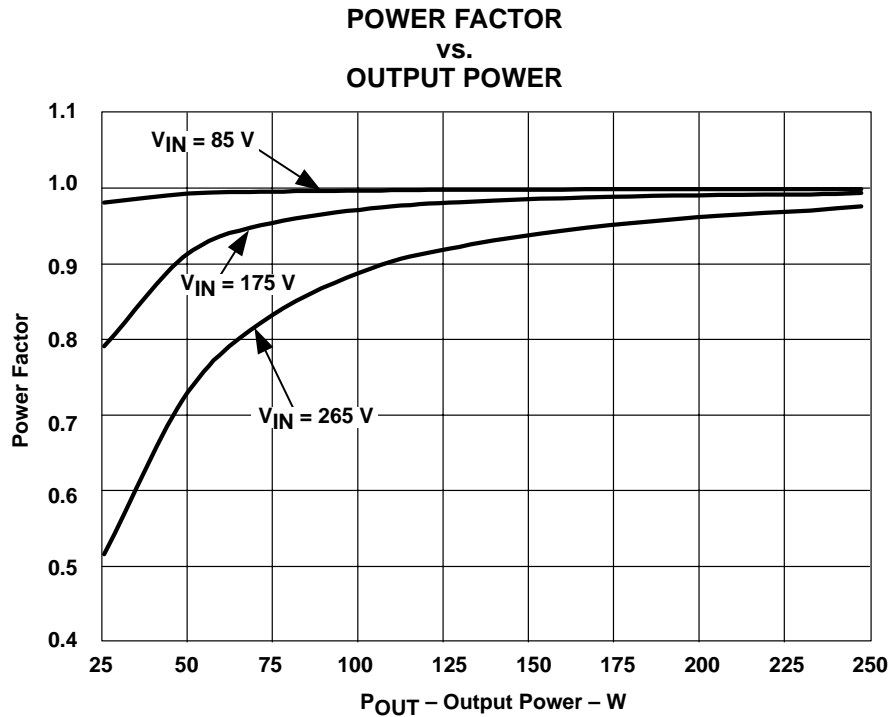

Figure 4.

6 Additional Information

For more information, pin description and specifications for the UCC3817 PFC Controller, please refer to the UCC3817 datasheet, TI Literature Number SLUS395, or contact the Texas Instruments Semiconductor Product Information Center at 1-800-336-5236 or 1-972-644-5580. Product information can also be found on the at <http://www.ti.com>.

This evaluation module can also be used to evaluate the performance of the UCC3818 PFC control IC by removing R16 and applying the bias voltage to the VCC pin through a separate bias supply.

DYNAMIC WARNINGS AND RESTRICTIONS

It is important to operate this EVM within the input voltage range of 85 V to 265 V ac and the output voltage of 385 V +/- 10%.

Exceeding the specified input range may cause unexpected operation and/or irreversible damage to the EVM. If there are questions concerning the input range, please contact a TI field representative prior to connecting the input power.

Applying loads outside of the specified output range may result in unintended operation and/or possible permanent damage to the EVM. Please consult the EVM User's Guide prior to connecting any load to the EVM output. If there is uncertainty as to the load specification, please contact a TI field representative.

During normal operation, some circuit components may have case temperatures greater than 50°C. The EVM is designed to operate properly with certain components above 50°C as long as the input and output ranges are maintained. These components include but are not limited to linear regulators, switching transistors, pass transistors, and current sense resistors. These types of devices can be identified using the EVM schematic located in the EVM User's Guide. When placing measurement probes near these devices during operation, please be aware that these devices may be very warm to the touch.

Mailing Address:

Texas Instruments
Post Office Box 655303
Dallas, Texas 75265

Copyright © 2001, Texas Instruments Incorporated

IMPORTANT NOTICE

Texas Instruments Incorporated and its subsidiaries (TI) reserve the right to make corrections, modifications, enhancements, improvements, and other changes to its products and services at any time and to discontinue any product or service without notice. Customers should obtain the latest relevant information before placing orders and should verify that such information is current and complete. All products are sold subject to TI's terms and conditions of sale supplied at the time of order acknowledgment.

TI warrants performance of its hardware products to the specifications applicable at the time of sale in accordance with TI's standard warranty. Testing and other quality control techniques are used to the extent TI deems necessary to support this warranty. Except where mandated by government requirements, testing of all parameters of each product is not necessarily performed.

TI assumes no liability for applications assistance or customer product design. Customers are responsible for their products and applications using TI components. To minimize the risks associated with customer products and applications, customers should provide adequate design and operating safeguards.

TI does not warrant or represent that any license, either express or implied, is granted under any TI patent right, copyright, mask work right, or other TI intellectual property right relating to any combination, machine, or process in which TI products or services are used. Information published by TI regarding third-party products or services does not constitute a license from TI to use such products or services or a warranty or endorsement thereof. Use of such information may require a license from a third party under the patents or other intellectual property of the third party, or a license from TI under the patents or other intellectual property of TI.

Reproduction of information in TI data books or data sheets is permissible only if reproduction is without alteration and is accompanied by all associated warranties, conditions, limitations, and notices. Reproduction of this information with alteration is an unfair and deceptive business practice. TI is not responsible or liable for such altered documentation.

Resale of TI products or services with statements different from or beyond the parameters stated by TI for that product or service voids all express and any implied warranties for the associated TI product or service and is an unfair and deceptive business practice. TI is not responsible or liable for any such statements.

Mailing Address:

Texas Instruments
Post Office Box 655303
Dallas, Texas 75265