

52KHz, 2A PWM Buck DC/DC Converter

❖ GENERAL DESCRIPTION

The AX3161 series are monolithic IC designed for a step-down DC/DC converter, and own the ability of driving a 2A load without additional transistor. It saves board space. The external shutdown function can be controlled by logic level and then come into standby mode. The internal compensation makes feedback control having good line and load regulation without external design. Regarding protected function, thermal shutdown is to prevent over temperature operating from damage, and current limit is against over current operating of the output switch. If current limit function occurs and V_{FB} is down below 0.5V, the switching frequency will be reduced. An external compensation is easily to system stable; the low ESR output capacitor can be used.

The AX3161 series operates at a switching frequency of 52KHz thus allow smaller sized filter components than what would be needed with lower frequency switching regulators. The output version included fixed 5V, 12V, and an adjustable type. The chips are available in standard TO263-5L, TO220-5L and TO220-5LR packages.

❖ FEATURES

- Output voltage: 5V and adjustable output version.
- Adjustable version output voltage range, 1.23V to 57V.
- 52KHz fixed switching frequency.
- Voltage mode non-synchronous PWM control.
- Thermal-shutdown and current-limit protection.
- ON/OFF shutdown control input.
- Short Circuit Protect (SCP).
- Operating voltage can be up to 60V.
- Output load current: 2A.
- TO263-5L, TO220-5L and TO220-5LR Pb-Free packages.
- Low power standby mode.
- Built-in switching transistor on chip.

❖ BLOCK DIAGRAM

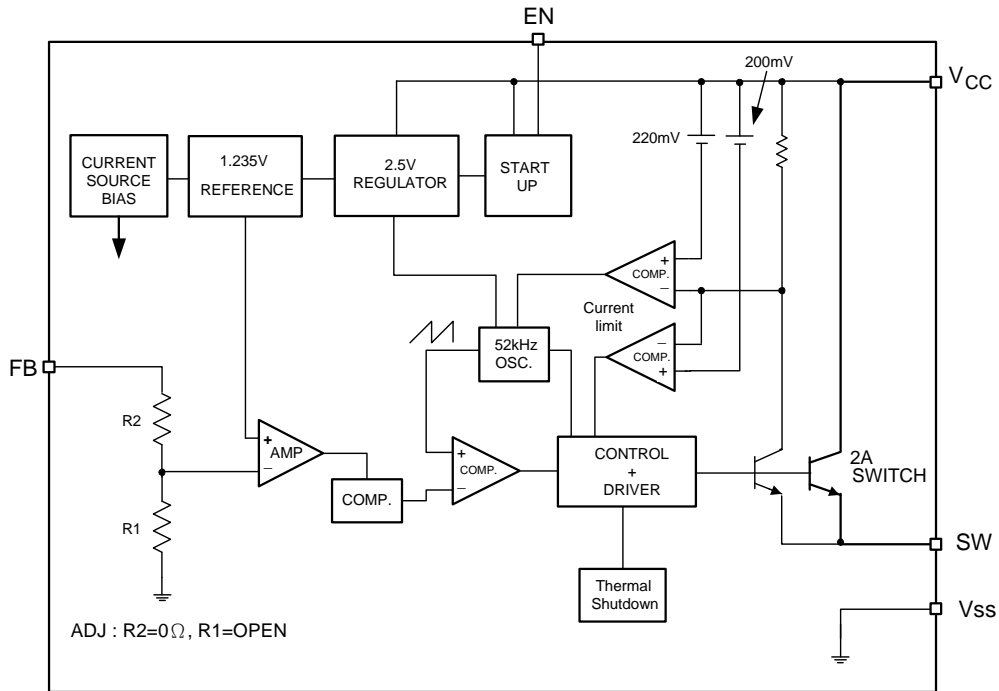

❖ PIN ASSIGNMENT

The packages of AX3161 are TO263-5L, TO220-5L and TO220-5LR the pin assignment is given by:

TO263-5L (Side View)

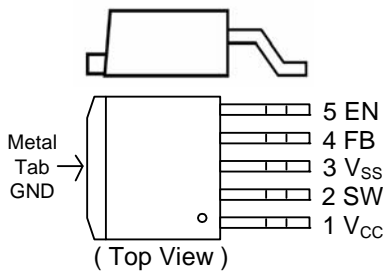

TO220-5L (Side View)

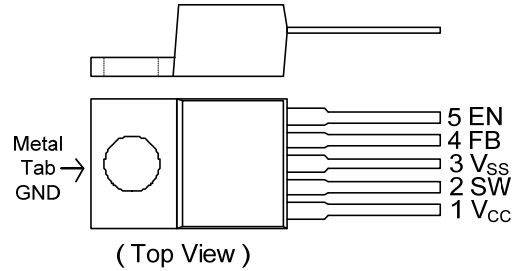

TO220-5LR (Side View)

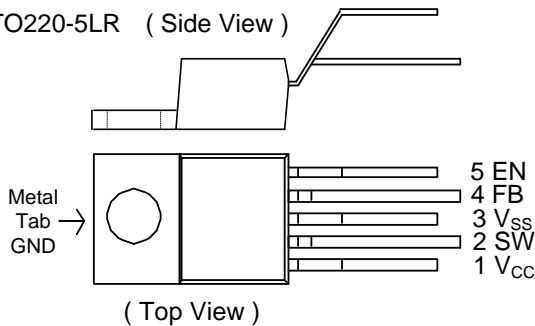

Name	Description
V _{CC}	Operating voltage input
SW	Switching output
V _{SS}	GND pin
FB	Output voltage feedback control
EN	ON/OFF Shutdown

❖ ORDER INFORMATION

Order Information	
AX3161-XX XXX X Output Voltage Package Type Packing 50: 5.0V M5: TO263-5L Blank : Tube Blank:ADJ T5: TO220-5L A : Taping T5R: TO220-5LR	
Top Marking	
ADJ Logo ← AX 3 1 6 1 → Part number YYWWX → ID code:internal → WW:01~52 → Year: 10=2010 11=2011	FIX Logo ← AX 3 1 6 1 → Part number - 5 0 → Output voltage YYWWX → ID code:internal → WW:01~52 → Year: 10=2010 11=2011

❖ ABSOLUTE MAXIMUM RATINGS

Characteristics	Symbol	Rating	Unit
Maximum Supply Voltage	V_{CC}	+63	V
ON/OFF Pin Input Voltage	V_{EN}	-0.3 to 35	V
Feedback Pin Voltage	V_{FB}	-0.3 to 35	V
Output Voltage to Ground	V_{OUT}	-0.8	V
Power Dissipation Internally limited	PD	$(T_J - T_A) / \theta_{JA}$	W
Storage Temperature Range	T_{ST}	-65 to +150	°C
Operating Junction Temperature Range	T_J	-40 to +125	°C
Operating Supply Voltage	V_{OP}	+4.5 to +60	V
Thermal Resistance from Junction to case	θ_{JC}	TO263=3.5, TO220=3.5	°C/W
Thermal Resistance from Junction to ambient	θ_{JA}	TO263=25, TO220=25	°C/W

Note 1: θ_{JA} is measured with the PCB copper area (need connect to V_{SS} pins) of approximately 3 in² (Multi-layer).

❖ ELECTRICAL CHARACTERISTICS

(Unless otherwise specified, $T_A=25^{\circ}\text{C}$, $V_{CC}=12\text{V}$, $I_{LOAD} = 0.2\text{A}$)

Characteristics	Symbol	Conditions	Min	Typ	Max	Units	
Quiescent Current	I_Q	$V_{FB}=1.5\text{V}$ for Adjustable version force driver off	-	4	8	mA	
Feedback bias current	I_{FB}	$V_{FB}=1.3\text{V}$ (Adjustable version only)	-	-10	-50	nA	
Shutdown supply Current	I_{SD}	EN pin=5V $V_{CC}=60\text{V}$	-	100	200	uA	
Oscillator frequency	F_{OSC}		40	52	65	KHz	
Oscillator frequency of short circuit protect	F_{SCP}	(Adjustable) When $V_{FB}<0.5\text{V}$	-	15	-	KHz	
		(Fixed)When $< V_{OUT}*40\%$	-	15	-	KHz	
Max. Duty Cycle (ON)	DC	$V_{FB}=0\text{V}$ force driver on	-	100	-	%	
Min. Duty Cycle (OFF)		$V_{FB}=1.5\text{V}$ for Adjustable version force driver off	-	0	-		
Current limit	I_{CL}	Pear current, No outside circuit $V_{FB}=0\text{V}$ force driver on	2.3	-	-	A	
Load Regulation($\Delta V_{OUT}/V_{OUT}$)	ΔV_{OUT}	$I_{OUT} = 0.2$ to 2A	-	0.6	1.2	%	
Saturation voltage	V_{SAT}	$I_{OUT}=2\text{A}$, No outside circuit $V_{FB}=0\text{V}$ force driver on	-	1.2	1.4	V	
SW pin leakage current	SW Pin=0V	I_{SWL}	No outside circuit $V_{FB}=1.5\text{V}$ for Adjustable version force driver off $V_{CC}=60\text{V}$ force driver off	-	-	-200	uA
	SW Pin=-0.8V			-	-5	-	mA
EN pin logic input threshold voltage	V_{IL}	Low (regulator ON)	-	1.3	0.6	V	
	V_{IH}	High (regulator OFF)	2.0		-		
EN pin logic input current	I_H	$V_{EN}=2.5\text{V}$ (OFF)	-	-0.1	-10	uA	
EN pin input current	I_L	$V_{EN}=0.5\text{V}$ (ON)	-	-0.01	-1	uA	
Thermal shutdown Temp	T_{SD}		-	150	-	$^{\circ}\text{C}$	

❖ ELECTRICAL CHARACTERISTICS (CONTINUED)

Version	Characteristics	Symbol	Conditions	Min	Typ	Max	Units
AX3161-ADJ	Output Feedback voltage	V_{FB}	$I_{LOAD} = 0.2A$ V_{OUT} programmed for 3.3V	1.193	1.23	1.267	V
	Efficiency	η	$V_{CC} = 12V, I_{LOAD} = 2A$	-	79	-	%
AX3161-5.0V	Output voltage	V_{OUT}	$I_{LOAD} = 0.2A$	4.85	5.00	5.15	V
	Efficiency	η	$V_{CC} = 12V, I_{LOAD} = 2A$	-	83	-	%

❖ APPLICATION CIRCUIT

(1) Fixed Output Voltage Versions

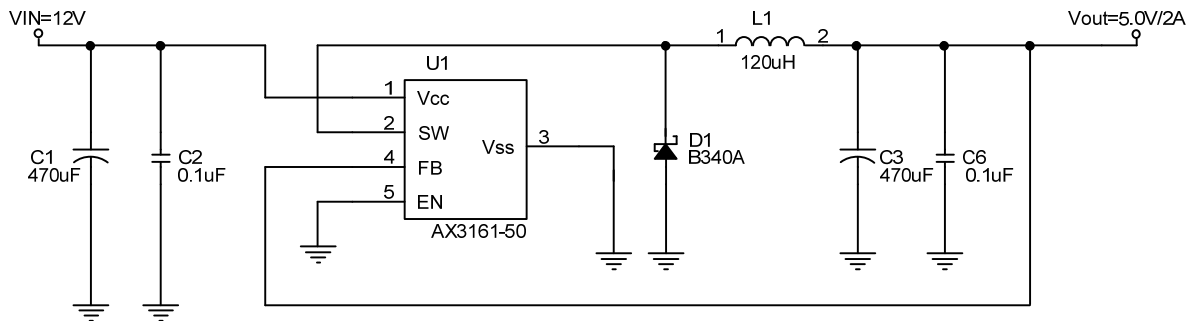

(2) Adjustable Output Voltage Version with Delayed Startup

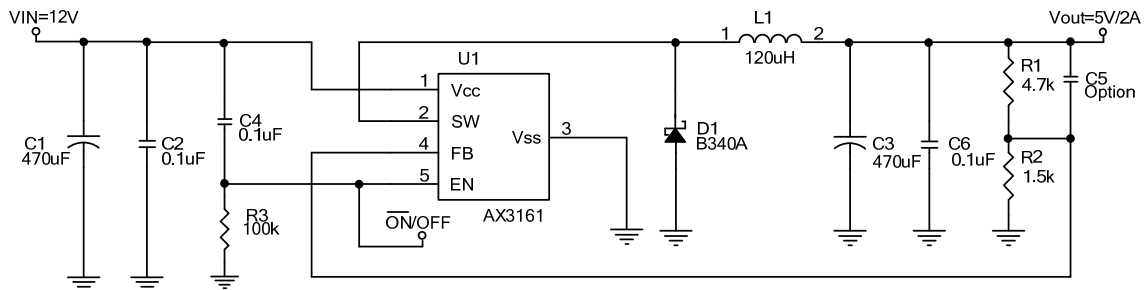

$$V_{OUT} = V_{FB} \times \left(1 + \frac{R1}{R2}\right), V_{FB} = 1.23V, R2 = 0.47K \sim 3K$$

Table 1 Resistor select for output voltage setting

V_{OUT}	R2	R1
3.3V	1.5K	2.5K
5V	1.5K	4.7K
12V	1.5K	13K

L1 recommend value ($I_{OUT}=2A$,)			
V_{OUT}	3.3V	5V	12V
$V_{IN}=12V$	100uH	120uH	NA
$V_{IN}=24V$	120uH	150uH	200uH
$V_{IN}=32\sim 48V$	120uH	150uH	300uH

❖ FUNCTION DESCRIPTION

Pin Functions

V_{CC}

This is the positive input supply for the IC switching regulator. A suitable input bypass capacitor must be presented at this pin to minimize voltage transients and to supply the switching currents needed by the regulator.

V_{SS}

Circuit ground.

SW

Internal switch. The voltage at this pin switches between $(+V_{CC} - V_{SAT})$ and approximately $-0.5V$, with a duty cycle of approximately V_{OUT} / V_{CC} . To minimize coupling to sensitive circuitry, the PC board copper area connected to this pin should be minimized.

Feedback

Senses the regulated output voltage to complete the feedback loop.

EN

Allows the switching regulator circuit to be shutdown using logic level signals thus dropping the total input supply current to approximately 100uA. Pulling this pin below a threshold voltage of approximately 1.3V turns the regulator on, and pulling this pin above 1.3V (up to a maximum of V_{CC}) shuts the regulator down. If this shutdown feature is not needed, the EN pin can be wired to the ground pin.

Output Capacitor Selection

The output capacitor is required to filter the output and provide regulator loop stability. The important capacitor parameters are; the 100 KHz Equivalent Series Resistance (ESR), the RMS ripples current rating, voltage rating, and capacitance value. For the output capacitor, the ESR value is the most important parameter. The ESR can be calculated from the following formula.

$$V_{RIPPLE} = \Delta I_L \times ESR = 0.4A \times 80m\Omega = 32mV$$

An aluminum electrolytic capacitor's ESR value is related to the capacitance and its voltage rating. In most case, higher voltage electrolytic capacitors have lower ESR values. Most of the time, capacitors with much higher voltage ratings may be needed to provide the low ESR values required for low output ripple voltage. It is recommended to replace this low ESR capacitor by using a 470 μ F low ESR values < 80m Ω .

Thermal Considerations

The data for these curves was taken with the AX3161 operating as a buck-switching regulator in an ambient temperature of 25°C (still air). These temperature increments are all approximate and are affected by many factors. Higher ambient temperatures require more heat sinker.

For the best thermal performance, wide copper traces and generous amounts of printed circuit board copper (need connect to the V_{SS} pins) should be used in the board layout, (One exception is the SW(switch) pin, which should not have large areas of copper.) Large areas of copper provide the best transfer of heat (lower thermal resistance) to the surrounding air, and moving air lowers the thermal resistance even further.

Package thermal resistance and junction temperature increments are all approximate. The increments are affected by a lot of factors. Some of these factors include board size, shape, thickness, position, location, and even board temperature. Other factors are, trace width, total printed circuit copper area, copper thickness, single or double-sided, multi-layer board and the amount of solder on the board.

The effectiveness of the PC board to dissipate heat also depends on the size, quantity and spacing of other components on the board, as well as whether the surrounding air is still or moving. Furthermore, some of these components such as the catch diode will add heat to the PC board and the heat can vary as the input voltage changes. For the inductor, depending on the physical size, type of core material and the DC resistance, it could either act as a heat sink taking heat away from the board, or it could add heat to the board.

❖ TYPICAL CHARACTERISTICS

Power on test wave
($V_{IN}=12V$, $V_{OUT}=3.3V$, $I_{OUT}=2A$)

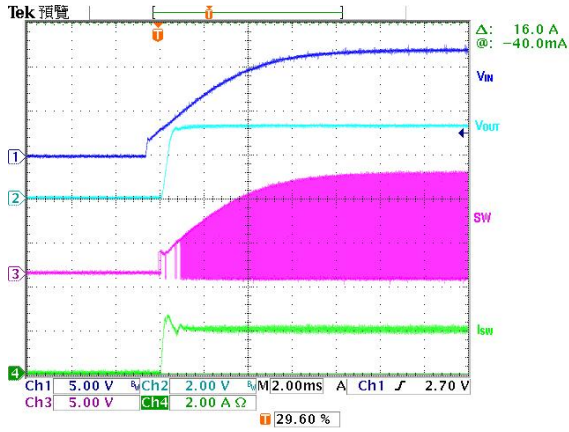

EN on test wave
($V_{IN}=12V$, $V_{OUT}=5V$, $I_{OUT}=2A$)

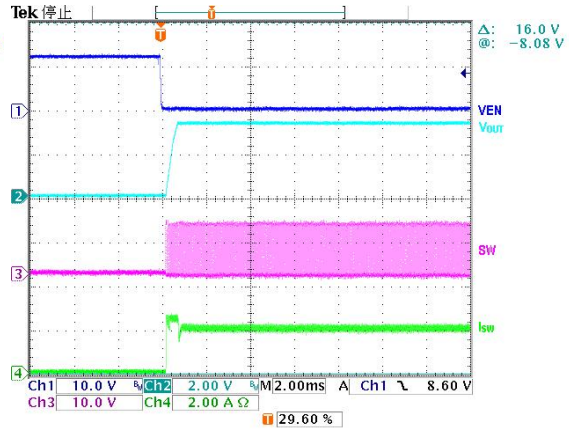

Load Transient Response
($V_{IN}=12V$, $V_{OUT}=3.3V$, $I_{OUT}=0.2\sim 2A$)

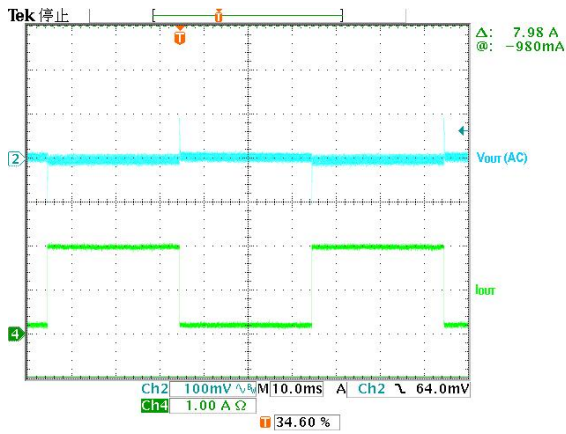

Efficiency
($V_{OUT}=3.3V$)

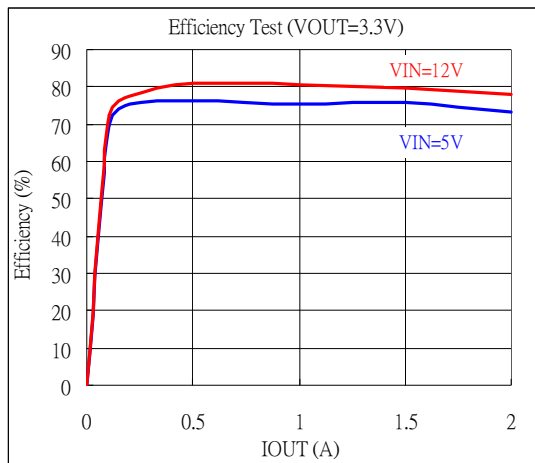

Efficiency
($V_{OUT}=5.0V$)

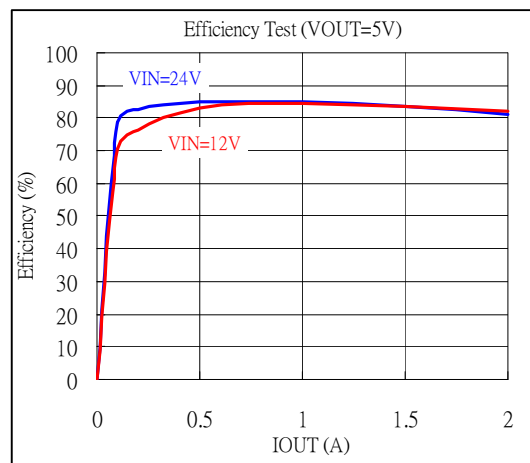

❖ PACKAGE OUTLINES

(1) T0263-5L

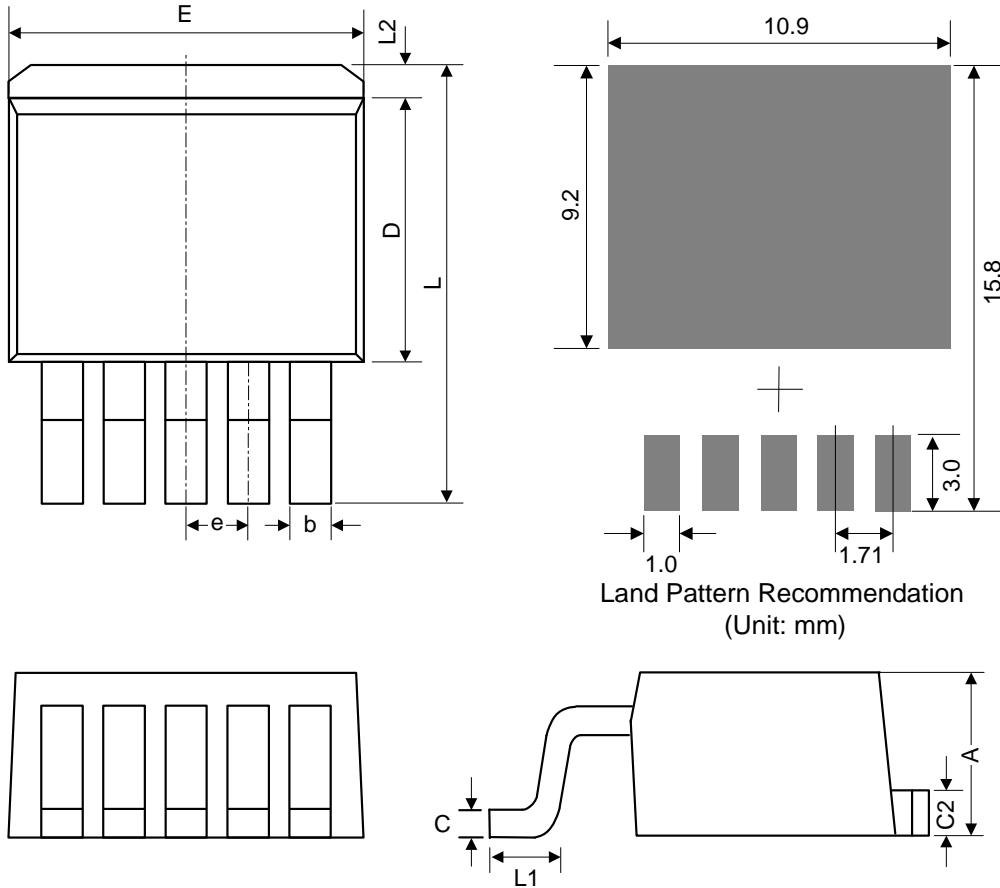

Symbol	Dimensions in Millimeters			Dimensions in Inches		
	Min.	Nom.	Max.	Min.	Nom.	Max.
A	4.06	4.45	4.83	0.16	0.175	0.19
b	0.51	0.76	0.99	0.02	0.03	0.039
C	0.38	0.56	0.74	0.015	0.022	0.029
C2	1.14	1.4	1.65	0.045	0.055	0.065
D	8.38	9.02	9.65	0.33	0.355	0.38
E	9.65	10.2	10.7	0.38	0.4	0.42
e	1.70 BSC			0.067 BSC		
L	14.6	15.2	15.9	0.575	0.6	0.625
L1	1.78	2.29	2.79	0.07	0.09	0.11
L2	-	-	1.68	-	-	0.066

Mold flash shall not exceed 0.005inch per side

JEDEC outline: TO-263 BA

(2) TO220-5L

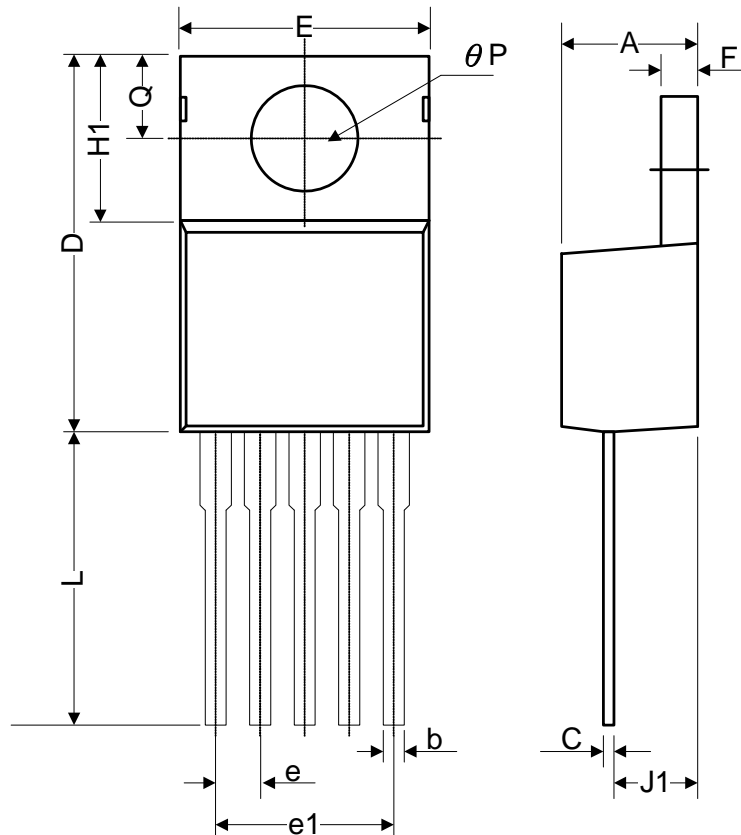

Symbol	Dimensions in Millimeters			Dimensions in Inches		
	Min.	Nom.	Max.	Min.	Nom.	Max.
A	4.07	4.45	4.82	0.16	0.175	0.19
b	0.76	0.89	1.02	0.03	0.035	0.04
C	0.36	0.5	0.64	0.014	0.02	0.025
D	14.22	14.86	15.5	0.56	0.585	0.61
E	9.78	10.16	10.54	0.385	0.4	0.415
e	1.57	1.71	1.85	0.062	0.067	0.073
e1	6.68	6.81	6.93	0.263	0.268	0.273
F	1.14	1.3	1.45	0.045	0.051	0.057
H1	5.46	6.16	6.86	0.215	0.243	0.27
J1	2.29	2.74	3.18	0.09	0.108	0.125
L	13.21	13.97	14.73	0.52	0.55	0.58
theta P	3.68	3.81	3.96	0.145	0.15	0.156
Q	2.54	2.73	2.92	0.1	0.107	0.115

Mold flash shall not exceed 0.005inch per side

JEDEC outline: NA

(3) TO220-5LR

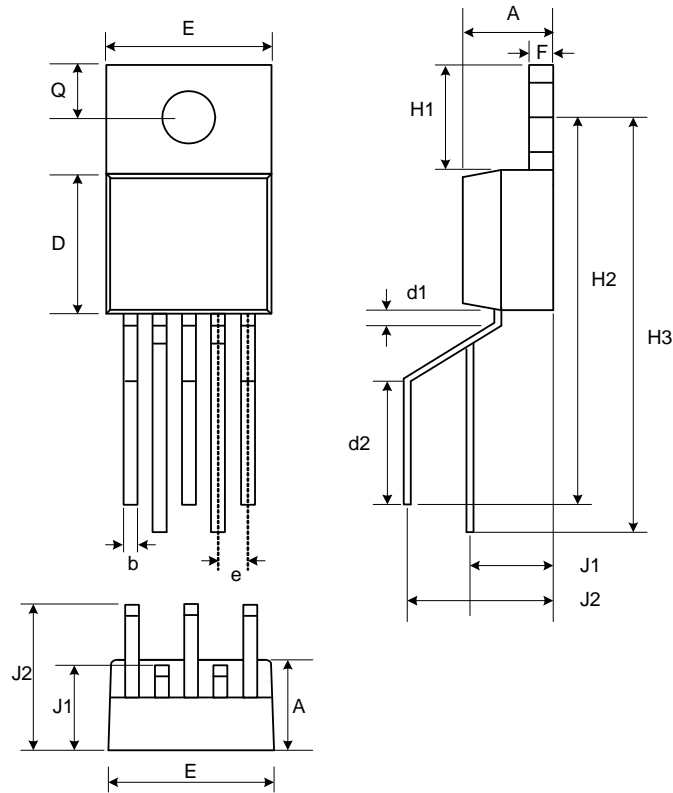

Symbol	Dimensions in Millimeters			Dimensions in Inches		
	Min.	Nom.	Max.	Min.	Nom.	Max.
A	4.4	4.6	4.7	0.175	0.180	0.185
b	0.7	0.8	0.9	0.027	0.032	0.037
D	8.4	8.7	8.9	0.330	0.340	0.350
d1	1.0			0.039		
d2	6.3			0.248		
E	9.91	10.16	10.41	0.390	0.400	0.410
e	1.6	1.7	1.8	0.062	0.067	0.072
F	1.2	1.25	1.3	0.048	0.050	0.052
H1	6.4			0.250		
H2	20.8	21.6	22.4	0.820	0.850	0.880
H3	23.9	24.7	25.5	0.942	0.972	1.002
J1	3.7	4.5	5.3	0.147	0.177	0.207
J2	8.4			0.331		
Q	2.5	2.8	3.0	0.100	0.110	0.120