

## High Precision Primary Side Regulation (PSR) CV/CC Power Switch

### FEATURES

- ◆ Built-in 600V Power MOSFET
- ◆ Low Standby Power Under 30mW, Easily to Pass Energy Star EPS2.0
- ◆ Primary Side Regulation (PSR) without TL431 and Opto-Coupler
- ◆  $\pm 5\%$  Constant Current (CC) and Constant Voltage (CV) Regulation at Universal AC Input
- ◆ Proprietary Cable Voltage Drop Compensation in CV Mode
- ◆ Compensate for Line Voltage Variation
- ◆ Compensate for Transformer Inductance Tolerances
- ◆ Built-in Control Loop Compensation in CV Mode
- ◆ All Pins Floating Protection
- ◆ PFM Control Eases EMI Design
- ◆ Cycle-by-Cycle Current Limiting
- ◆ Built-in Leading Edge Blanking (LEB)
- ◆ Built-in Soft Start
- ◆ Output Over Voltage Protection
- ◆ VDD OVP & Clamp
- ◆ VDD Under Voltage Lockout (UVLO)

### APPLICATIONS

- ◆ Battery chargers for cellular phones, cordless phones, PDA, digital cameras, etc
- ◆ Replaces linear transformer and RCC SMPS
- ◆ Small power adapter
- ◆ AC/DC LED lighting

### TYPICAL APPLICATION

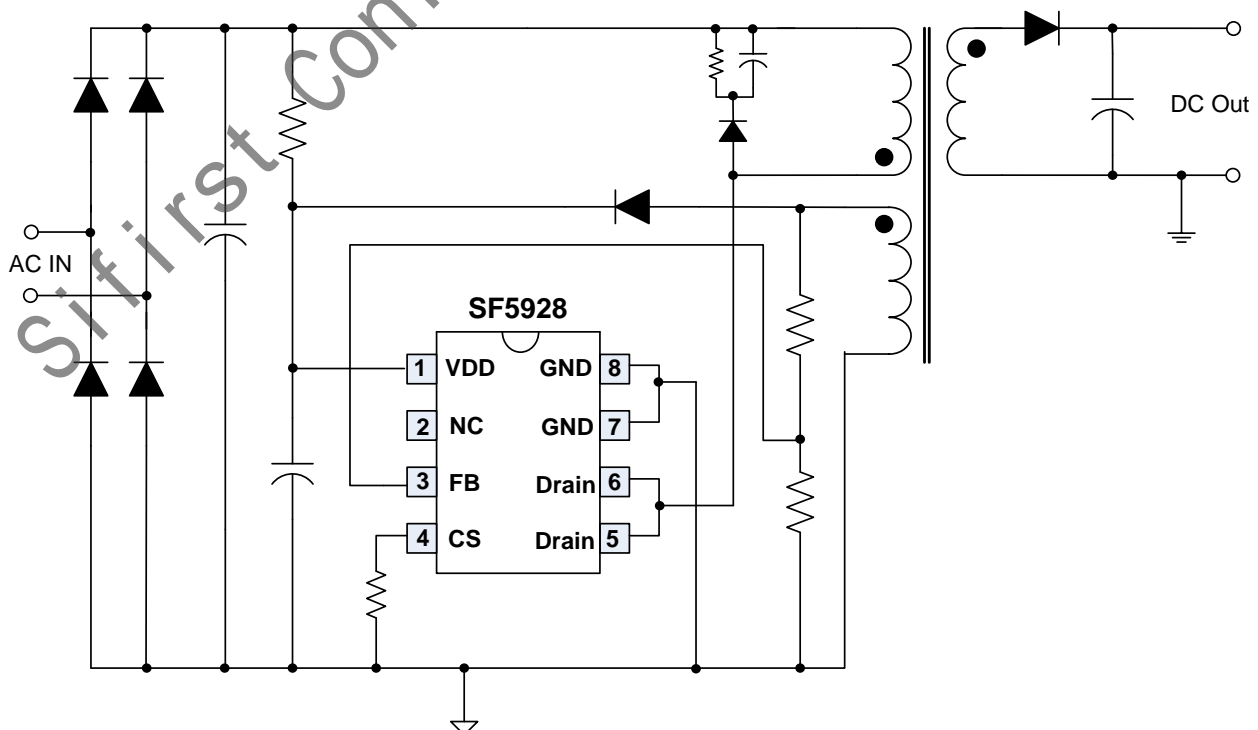

### GENERAL DESCRIPTION

SF5928 is a high performance, highly integrated DCM (Discontinuous Conduction Mode) Primary Side Regulation (PSR) power switch for offline small power converter applications.

SF5928 uses Pulse Frequency Modulation (PFM) control to improve efficiency and eases system EMI design. The IC dramatically lowers system cost by eliminating the opto-coupler and secondary control circuits. It also can provide very tight output voltage regulation (CV), in addition to output current control (CC) ideal for charging applications.

SF5928 has Error Amplifier (EA) CV with built-in loop compensation network for CV control, which eliminates external compensation circuitry. It has built-in cable drop compensation function, which can provide excellent CV performance. The IC also has built-in soft start function to soften the stress on the MOSFET during power on period. Under light load conditions, the IC decreases switching frequency to achieve excellent regulation and high efficiency, yet meets the requirement for no-load consumption less than 30mW.

SF5928 integrates functions and protections of Under Voltage Lockout (UVLO), VDD Over Voltage Protection (VDD OVP), Output Over Voltage Protection (Output OVP), Soft Start, Cycle-by-cycle Current Limiting (OCP), All Pins Floating Protection, VDD Clamping.

SF5928 is available in DIP8 package.

**Pin Configuration**

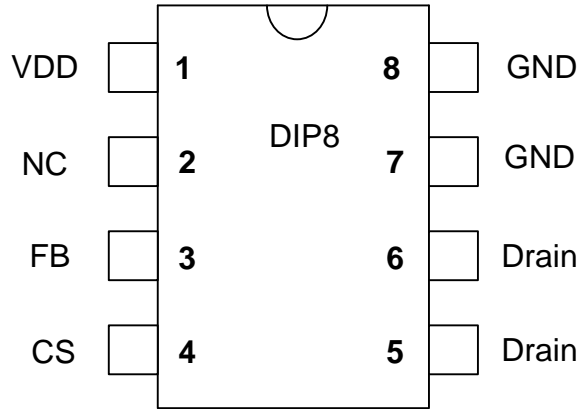

**Ordering Information**

Part Number	Top Mark	Package	Tape & Reel
SF5928DP	SF5928DP	DIP8	RoHs

**Output Power Table<sup>(1)</sup>**

Part Number	230VAC $\pm$ 15% <sup>(2)</sup>	85-265VAC
	Adapter <sup>(3)</sup>	Adapter <sup>(3)</sup>
SF5928	18W	13W

**Note 1.** The Max. output power is limited by junction temperature

**Note 2.** 230VAC or 100/115VAC with doublers

**Note 3.** Typical continuous power in a non-ventilated enclosed adapter with sufficient drain pattern as a heat sink at 50°C ambient.

**Block Diagram**

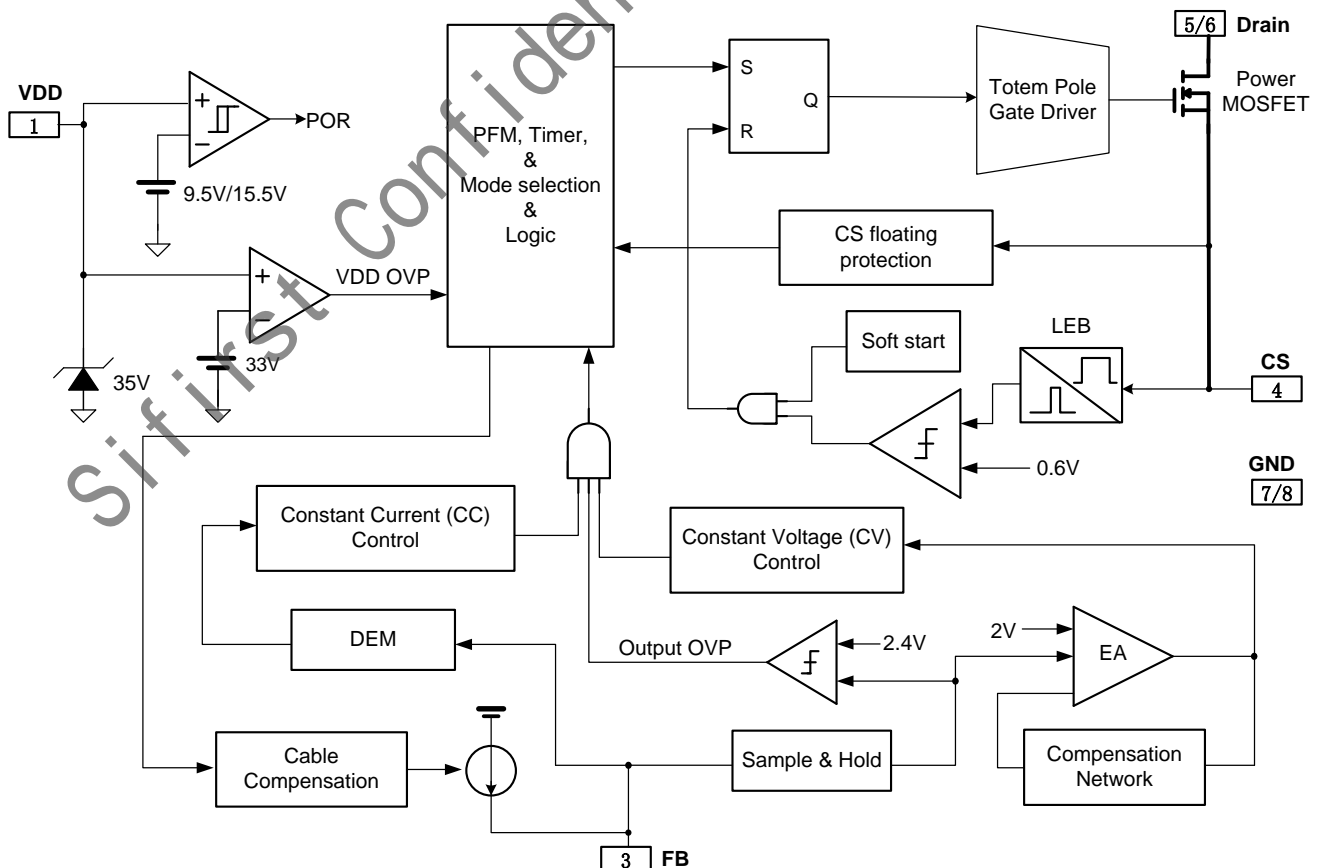

## Marking Information

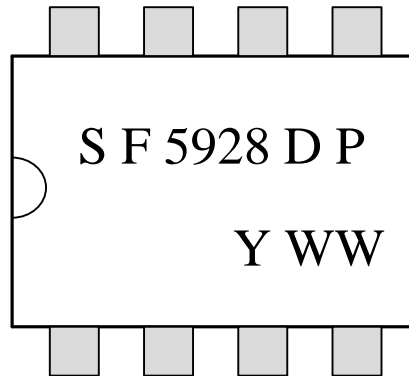

YWW: Year&amp;Week code

## Pin Description

Pin Num	Pin Name	I/O	Description
1	VDD	I	IC power supply pin.
2	NC	-	No connection.
3	FB	I	System feedback pin. This control input regulates both the output voltage in CV mode and output current in CC mode based on the flyback voltage of the auxiliary winding.
4	CS	I	Current sense pin.
5-6	Drain	P	High voltage power MOSFET drain connection.
7-8	GND	P	Ground

## Absolute Maximum Ratings (Note 4)

Parameter	Value	Unit
VDD DC Supply Voltage	35	V
VDD DC Clamp Current	10	mA
Drain pin	-0.3 to 600	V
FB, CS voltage range	-0.3 to 7	V
Package Thermal Resistance (DIP-8)	84	°C/W
Maximum Junction Temperature	150	°C
Operating Temperature Range	-40 to 85	°C
Storage Temperature Range	-55 to 150	°C
Lead Temperature (Soldering, 10sec.)	260	°C
ESD Capability, HBM (Human Body Model)	3	kV
ESD Capability, MM (Machine Model)	250	V

## Recommended Operation Conditions (Note 5)

Parameter	Value	Unit
Supply Voltage, VDD	11 to 30	V
Operating Ambient Temperature	-40 to 85	°C

**ELECTRICAL CHARACTERISTICS**(T<sub>A</sub> = 25°C, VDD=16V, if not otherwise noted)

Symbol	Parameter	Test Conditions	Min	Typ	Max	Unit
<b>Supply Voltage (VDD) Section</b>						
I_Startup	VDD Start up Current	VDD =UVLO(ON)-1V, Measure current into VDD		5	20	uA
I_VDD_Op	Operation Current	V <sub>FB</sub> =3V, VDD=20V		1	2	mA
UVLO(ON)	VDD Under Voltage Lockout Exit (Startup)		14	15.5	16.5	V
UVLO(OFF)	VDD Under Voltage Lockout Enter		8.5	9.5	10.5	V
VDD_OVP	VDD Over Voltage Protection trigger		31	33	35	V
V <sub>DD</sub> _Clamp	VDD Zener Clamp Voltage	I(V <sub>DD</sub> ) = 10 mA	33	35	37	V
T_Softstart	Soft Start Time <sup>(6)</sup>			2		mSec
<b>Feedback Input Section(FB Pin)</b>						
V <sub>FB_EA_Ref</sub>	Internal Error Amplifier(EA) reference input		1.98	2.0	2.02	V
V <sub>FB_OVP</sub>	Output over voltage protection threshold			2.4		V
V <sub>FB_DEM</sub>	Demagnetization comparator threshold			0.1		V
T <sub>min_OFF</sub>	Minimum OFF time	Note 6		2		uSec
T <sub>max_OFF</sub>	Maximum OFF time			12		mSec
T <sub>CC</sub> /T <sub>DEM</sub>	Ratio between switching period in CC mode and demagnetization time	Note 6		2		
I <sub>Cable_max</sub>	Max Cable compensation current			40		uA
<b>Current Sense Input Section (CS Pin)</b>						
T <sub>blanking</sub>	CS Input Leading Edge Blanking Time			500		nSec
V <sub>th_OC</sub>	Current limiting threshold		588	600	612	mV
T <sub>D_OC</sub>	Over Current Detection and Control Delay			100		nSec
<b>Power MOSFET Section<sup>(7)</sup></b>						
BV <sub>dss</sub>	Power MOSFET Drain Source Breakdown Voltage		600			V
R <sub>dson</sub>	Static Drain-Source On Resistance	I(Drain)=1A		3.8	4.7	Ω
I <sub>dss</sub>	Zero Gate Voltage Drain Current				1	uA
T <sub>d(on)</sub>	Turn-on delay time			9		ns
T <sub>d(off)</sub>	Turn-off delay time			24		ns

**Note 4.** Stresses beyond those listed under “Absolute Maximum Ratings” may cause permanent damage to the device. These are stress ratings only, and functional operation of the device at these or any other conditions beyond those indicated in the operational sections of the specifications is not implied. Exposure to absolute maximum rating conditions for extended periods may affect device reliability.

**Note 5.** The device is not guaranteed to function outside its operating conditions.

**Note 6.** Guaranteed by design.

**Note 7.** These parameters, although guaranteed, are not 100% tested in production

CHARACTERIZATION PLOTS

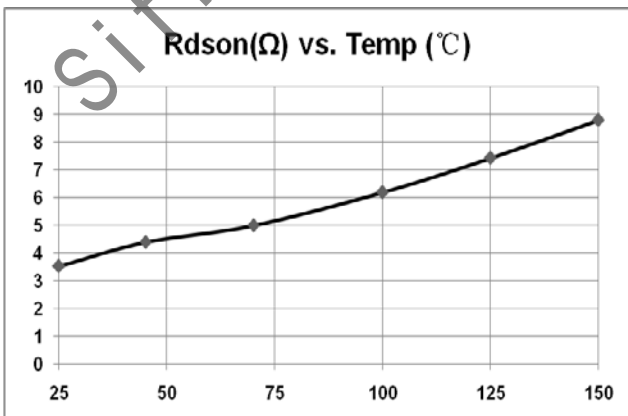
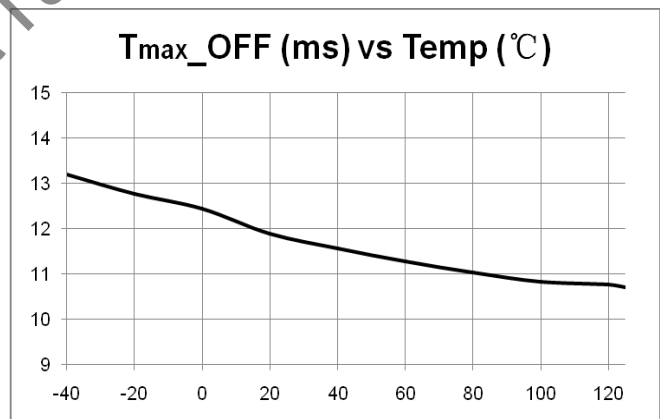
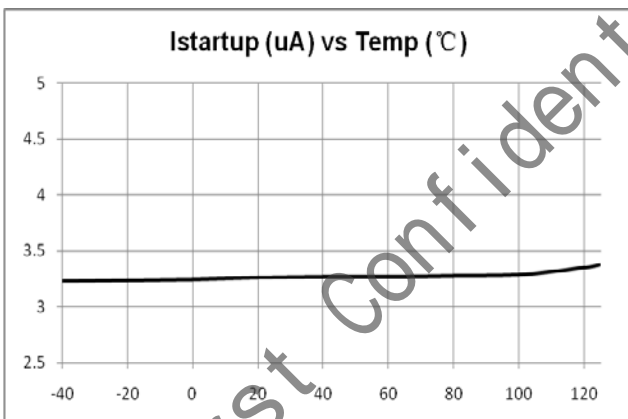
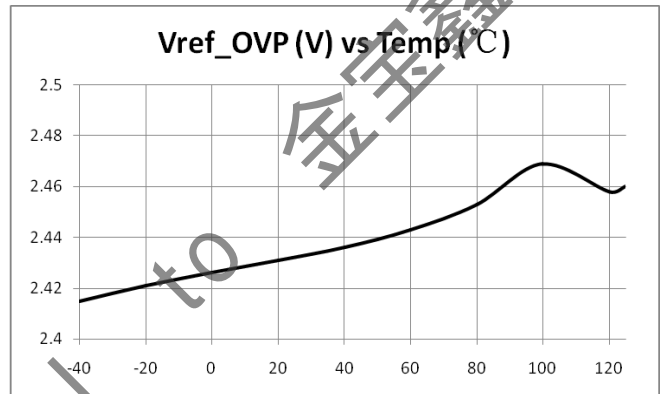
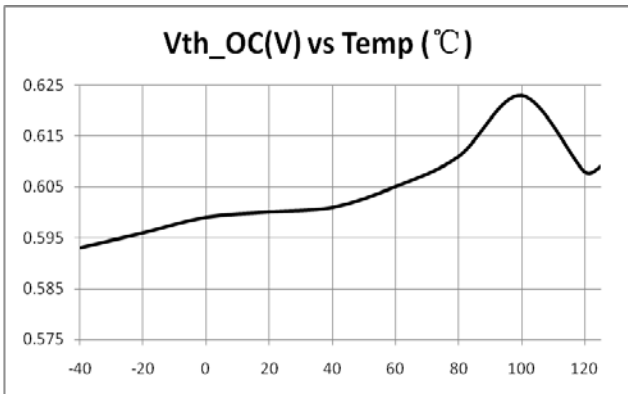
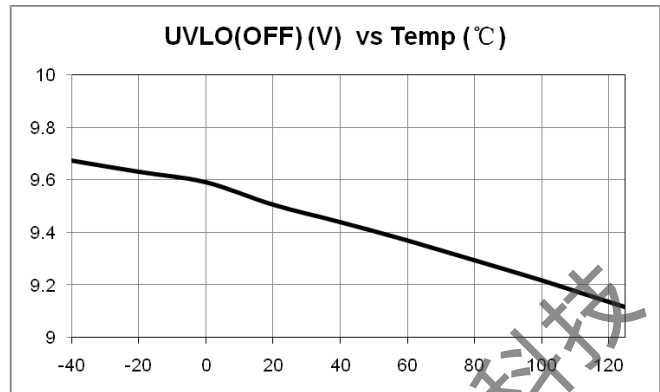
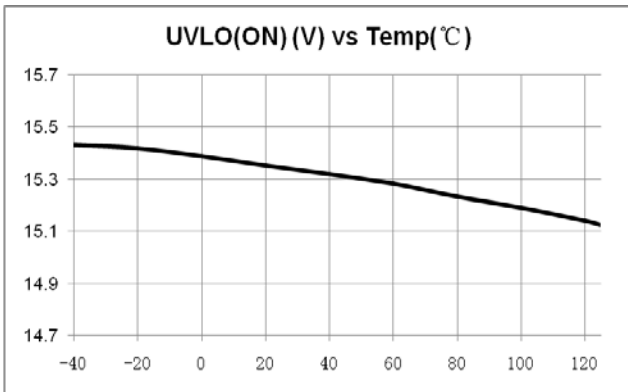

**OPERATION DESCRIPTION**

SF5928 is a high performance, highly integrated DCM (Discontinuous Conduction Mode) Primary Side Regulation (PSR) power switch working in PFM (Pulse Frequency Modulation) mode. The built-in power MOSFET and high precision CV/CC control with high level protection features make it very suitable for offline small power converter applications.

◆ **PSR Technology Introduction**

Assuming the system works in DCM mode, the power transfer function is given by

$$P = \frac{\eta}{2} \times L_m \times I_{pk}^2 \times f_s = V_o \times I_o \quad (\text{Eq.1})$$

In the equation above, P is output power, Vo and Io are system output voltage and current respectively, η is system power transfer efficiency, Lm is transformer primary inductance, fs is system switching frequency, Ipk is primary peak current in a switching cycle. The following figure illustrates the waveform in a switching cycle.

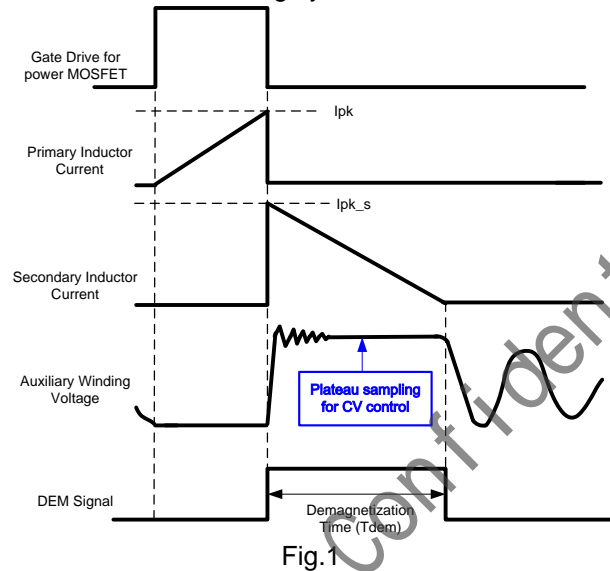

Fig.1

In the figure shown above, the IC generates a demagnetization signal (DEM) in each switching cycle through auxiliary winding. Tdem is demagnetization time for CV/CC control. In DCM mode, Tdem can be expressed as;

$$\frac{V_o}{L_m} \times T_{dem} = \frac{N_s}{N_p} \times I_{pk} \quad (\text{Eq.2})$$

In Eq.2, Np and Ns are primary and secondary winding turns respectively.

Combined with Eq.1 and Eq. 2, the average output current can be expressed as:

$$I_o = \frac{\eta}{2} \times I_{pk} \times \frac{N_p}{N_s} \times f_s \times T_{dem} \quad (\text{Eq.3})$$

**CC (Constant Current) Control Scheme**

From Eq.3, it can be easily seen that there are two ways to implement CC control: one is PFM (Pulse

Frequency Modulation), the control scheme is to keep Ipk to be constant, let the product of Ts and Tdem (fs\*Tdem) to be a constant. In this way, Io will be a value independent to the variation of Vo, Lm, and line input voltage. Another realization method is PWM duty control, the control scheme is to keep fs to be constant, let the product of Tdem and Ipk (Tdem\*Ipk) to be a constant, in another words, by modulating system duty cycle to realize a constant Io independent to the variation of Vo, Lm and line voltages.

SF5928 adopts PFM for CC control, the product of Ts and Tdem is given by

$$f_s \times T_{dem} = 0.5 \quad (\text{Eq.4})$$

**CV (Constant Voltage) Control Scheme**

CV control should sample the plateau of auxiliary winding voltage in flyback phase, as shown in Fig.1 The CV control has many implementations, for example, PWM, or PFM, or a combination of both one. In SF5928, the PFM control is adopted for CV control.

◆ **PFM Control Eases System EMI Design**

As mentioned above, the CC/CV control in SF5928 uses PFM control, which will ease system EMI design greatly. Since PFM control is a frequency variation system with inherent frequency shuffling function, it will have superior EMI performance than that of PWM control.

◆ **Precision CV/CC Performance with Smooth Transition between CV and CC**

In SF5928, the parameters is trimmed to tight range, which makes the system CC/CV to have less than 5% variation.

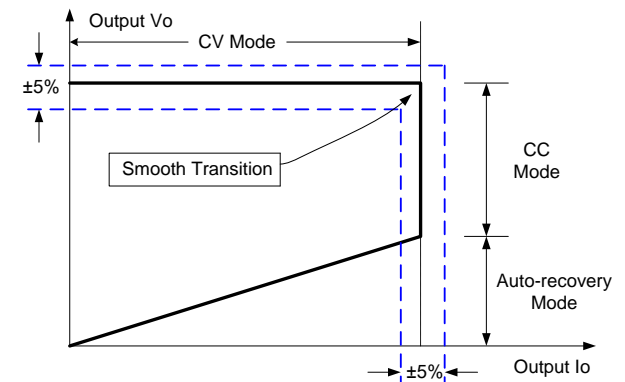

Fig.2

In SF5928, the IC has specially designed to be able to smoothly transit between CC and CV mode. When the output voltage is too low, the IC will enter into auto-recovery mode, as shown in Fig. 2

◆ **Startup Current and Startup Control**

Startup current of SF5928 is designed to be very low (typically 5uA) so that VDD could be charged

up above UVLO(ON) threshold level and device starts up quickly. A large value startup resistor can therefore be used to minimize the power loss yet reliable startup in application.

#### ◆ Operating Current

The operating current in SF5928 is as small as 1mA (typical). The small operating current results in higher efficiency and reduces the VDD hold-up capacitance requirement. Once SF5928 enters very low frequency PFM mode, the operating frequency is reduced to less than 0.3mA, assisting the power supply in meeting power conservation requirements.

#### ◆ Soft Start

SF5928 features an internal 2ms (typical) soft start that slowly increases the threshold of cycle-by-cycle current limiting comparator during startup sequence. It reduces the stress on the secondary diode during startup. Every startup process is followed by a soft start activation.

#### ◆ Proprietary Cable Voltage Drop Compensation in CV Mode

When it comes to cellular phone charger applications, the battery is located at the end of cable, which causes typically several percentage of voltage drop on the actual battery voltage. SF5928 has a proprietary built-in cable voltage drop compensation block which can provide a constant output voltage at the end of the cable over the entire load range in CV mode.

#### ◆ Leading Edge Blanking (LEB)

Each time the power MOSFET is switched on, a turn-on spike occurs across the sensing resistor. To avoid premature termination of the switching pulse, an internal leading edge blanking circuit is built in. During this blanking period (300ns, typical), the cycle-by-cycle current limiting comparator is disabled and cannot switch off the gate driver. Thus, external RC filter with a small time constant is enough for current sensing.

#### ◆ Minimum and Maximum OFF Time

In SF5928, a minimum OFF time (typically 2us) is implemented to suppress ringing when GATE is off. The minimum OFF time is necessary in applications where the transformer has a large leakage inductance, particularly at low output voltages or startup. The maximum OFF time in SF5928 is typically 10ms, which provides a large range for frequency reduction. In this way, a low standby power of 30mW can be achieved.

#### ◆ All Pins Floating Protection

In SF5928, if pin floating situation occurs, the IC is designed to have no damage to system.

#### ◆ Output OVP(Over Voltage Protection)

In SF5928, the output OVP is integrated by plateau sampling the auxiliary winding in flyback phase. The threshold voltage for output OVP is 2.4V, as shown in Fig.3. Output OVP is auto-recovery mode protection (mentioned below).

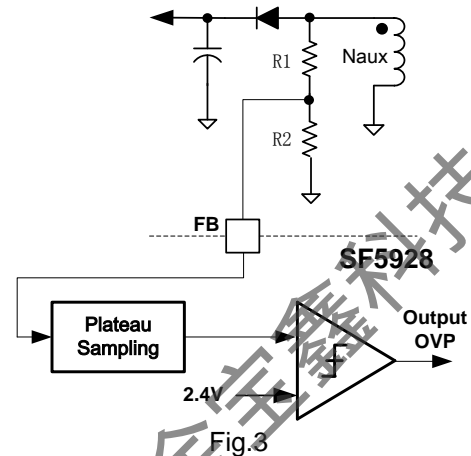

#### ◆ VDD OVP(Over Voltage Protection)

VDD OVP (Over Voltage Protection) is implemented in SF5928 and it is a protection of auto-recovery mode.

#### ◆ Auto Recovery Mode Protection

As shown in Fig.4, once a fault condition is detected, switching will stop. This will cause VDD to fall because no power is delivered from the auxiliary winding. When VDD falls to UVLO(off) (typical 9V), the protection is reset and the operating current reduces to the startup current, which causes VDD to rise, as shown in Fig.4. However, if the fault still exists, the system will experience the above mentioned process. If the fault has gone, the system resumes normal operation. In this manner, the auto restart can alternatively enable and disable the switching until the fault condition is disappeared.

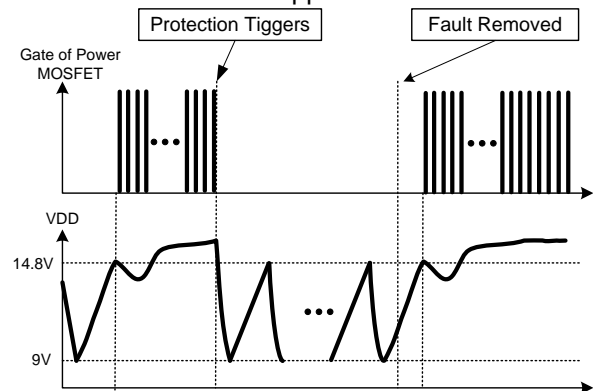
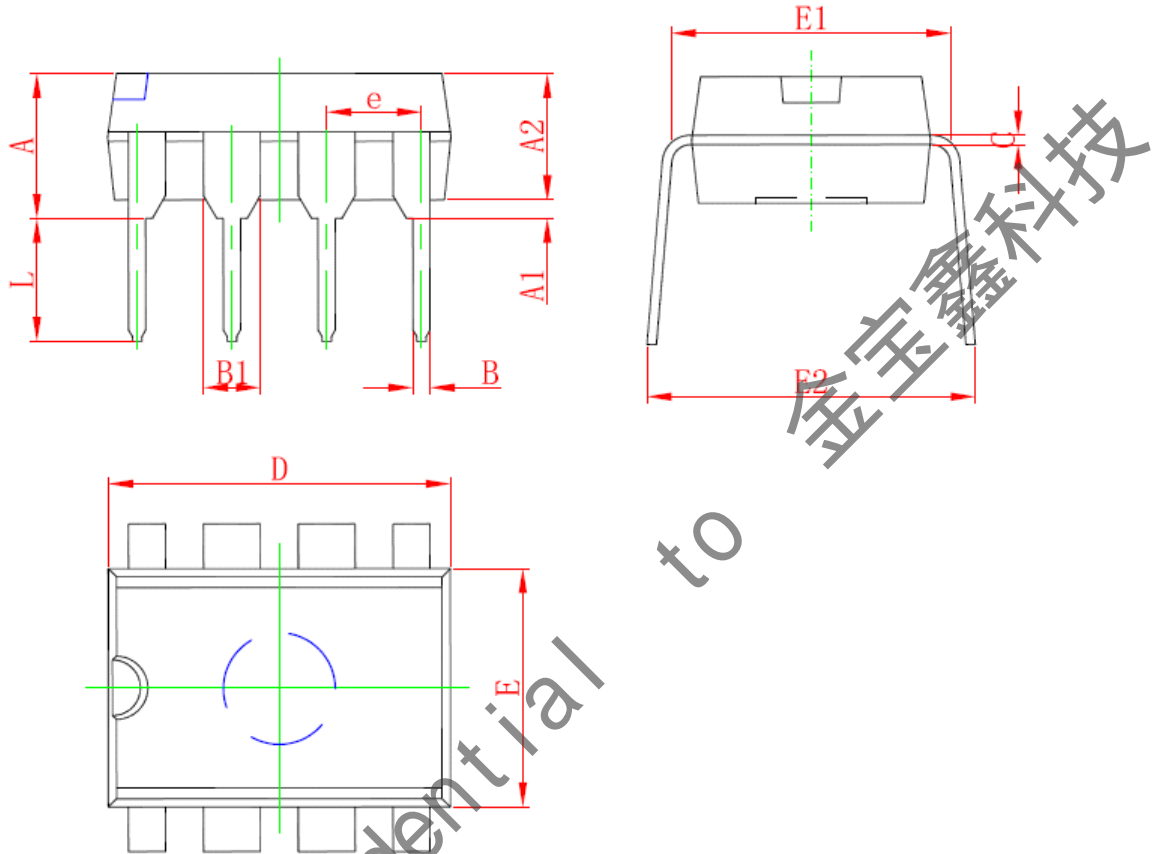

Fig.4

#### ◆ Soft Gate Driver for Power MOSFET

The driving stage of SF5928 is a soft totem-pole gate driver to minimize EMI. Cross conduction has been avoided to minimize heat dissipation, increase efficiency, and enhance reliability.

**PACKAGE MECHANICAL DATA**
**DIP8 PACKAGE OUTLINE DIMENSIONS**

Symbol	Dimensions In Millimeters		Dimensions In Inches	
	Min	Max	Min	Max
A	3.710	5.334	0.146	0.210
A1	0.381		0.015	
A2	3.175	3.600	0.125	0.142
B	0.350	0.650	0.014	0.026
B1	1.524 (BSC)		0.06 (BSC)	
C	0.200	0.360	0.008	0.014
D	9.000	10.160	0.354	0.400
E	6.200	6.600	0.244	0.260
E1	7.320	7.920	0.288	0.312
e	2.540 (BSC)		0.1 (BSC)	
L	2.921	3.810	0.115	0.150
E2	8.200	9.525	0.323	0.375



## IMPORTANT NOTICE

SiFirst Technology Nanhai, Ltd (SiFirst) reserves the right to make corrections, modifications, enhancements, improvements and other changes to its products and services at any time and to discontinue any product or service without notice. Customers should obtain the latest relevant information before placing orders and should verify that such information is current and complete.

SiFirst warrants performance of its hardware products to the specifications applicable at the time of sale in accordance with SiFirst's standard warranty. Testing and other quality control techniques are used to the extent SiFirst deems necessary to support this warranty. Except where mandated by government requirements, testing of all parameters of each product is not necessarily performed.

SiFirst assumes no liability for application assistance or customer product design. Customers are responsible for their products and applications using SiFirst's components. To minimize the risks associated with customer products and applications, customers should provide adequate design and operating safeguards.

Reproduction of SiFirst's information in SiFirst's data books or data sheets is permissible only if reproduction is without alteration and is accompanied by all associated warranties, conditions, limitations, and notices. Reproduction of this information with alteration is an unfair and deceptive business practice. SiFirst is not responsible or liable for such altered documentation. Information of third parties may be subject to additional restrictions.

Resale of SiFirst's products or services with statements different from or beyond the parameters stated by SiFirst for that product or service voids all express and any implied warranties for the associated SiFirst's product or service and is an unfair and deceptive business practice. SiFirst is not responsible or liable for any such statements.

SiFirst's products are neither designed nor intended for use in military applications. SiFirst will not be held liable for any damages or claims resulting from the use of its products in military applications.

SiFirst's products are not designed to be used as components in devices intended to support or sustain human life. SiFirst will not be held liable for any damages or claims resulting from the use of its products in medical applications.

SiFirst Confidential