

GENERAL DESCRIPTION

OB2203 is a highly integrated Quasi-Resonant (QR) controller optimized for high performance offline flyback converter applications.

At normal load condition, it operates in QR mode with minimum drain voltage switching. To meet the CISPR-22 EMI starting at 150KHz, the maximum switching frequency is internally limited to 130KHz. It operates in PFM mode for high conversion efficiency at light load condition. When the load is very small, the IC operates in 'Extended Burst Mode' to minimize the switching loss. As a result, lower standby power consumption and higher conversion efficiency are achieved.

A built-in P-channel MOSFET and its control are integrated to automatically turn on/off PFC stage according to the load conditions. When used with OB6563 (On-Bright's PFC controller), the standby power consumption of less than 400mW can be achieved in typical 150W SMPS.

OB2203 offers comprehensive protection coverage including Cycle-by-Cycle Current Limiting(OCP), VCC Under Voltage Lockout(UVLO), Output Over Voltage Protection(OVP), VCC Clamp, Gate Clamp, Over Load Protection(OLP), On-chip Thermal Shutdown, Programmable Soft Start, and External Latch Triggering, Max On-time Limit, etc.

OB2203 is offered in SOP-8 and DIP-8 packages.

FEATURES

- Multi-Mode Operation
 - Quasi-Resonant Operation at Normal Load
 - Pulse Frequency Modulation (PFM) Operation at Light Load
 - Burst Mode at No Load
- Direct Control of the Power Supply of PFC Controller for Improved Standby Power and efficiency at No/Light Load
- 130KHz Maximum Frequency Limit
- Internal Minimum T_{off} for Ringing Suppression
- 21us Maximum On Time Limit
- Internal Leading Edge Blanking
- Programmable Soft-start
- External Latch Triggering
- Internal Temperature Shutdown
- 1A Peak Current Sink/Source Capability
- Programmable Over Voltage Protection (OVP)

APPLICATIONS

Offline AC/DC flyback converter for

- Power Adaptor and Open-frame SMPS
- LCD Monitor/TV/PC/Set-Top Box Power Supplies
- NB/DVD

TYPICAL APPLICATION

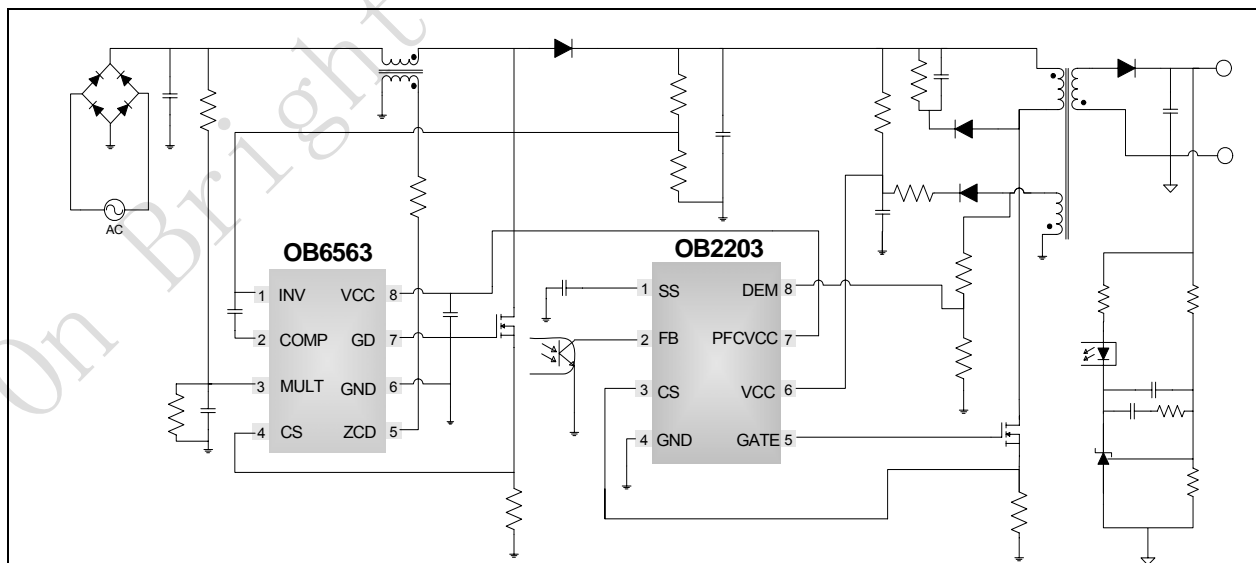

GENERAL INFORMATION

Pin Configuration

The pin map of OB2203 in DIP8 and SOP8 package is shown as below.

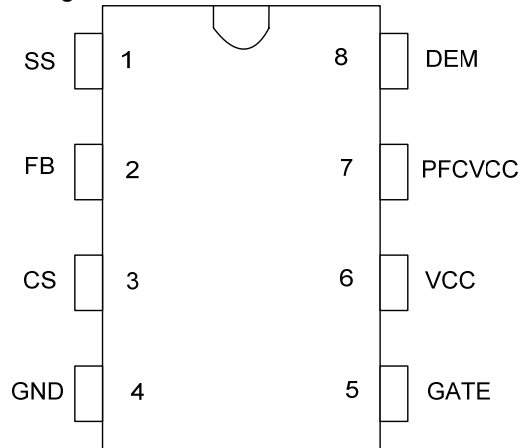

Ordering Information

Part Number	Description
OB2203AP	8 Pin DIP, Pb free in Tube
OB2203CP	8 Pin SOP, Pb free in Tube
OB2203CPA	8 Pin SOP, Pb free in T&R

Note: All Devices are offered in Pb-free Package if not otherwise noted.

Package Dissipation Rating

Package	R θ JA (C/W)
DIP8	90
SOP8	150

Absolute Maximum Ratings

Parameter	Value
VCC Zener Clamp Voltage	34 V
VCC Clamp Continuous Current	10 mA
SS Input Voltage	-0.3 to 7V
FB Input Voltage	-0.3 to 7V
CS Input Voltage	-0.3 to 7V
DEM Input Voltage	-0.3 to 7V
Min/Max Operating Junction Temperature T _J	-40 to 150 °C
Min/Max Storage Temperature T _{stg}	-55 to 150 °C
Lead Temperature (Soldering, 10secs)	260 °C

Note: Stresses beyond those listed under "absolute maximum ratings" may cause permanent damage to the device. These are stress ratings only, functional operation of the device at these or any other conditions beyond those indicated under "recommended operating conditions" is not implied. Exposure to absolute maximum-rated conditions for extended periods may affect device reliability.

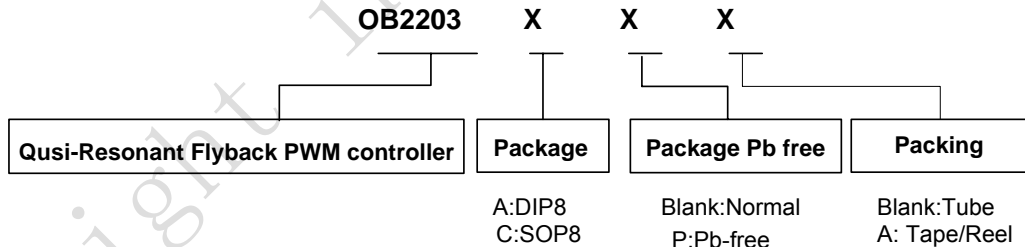

Marking Information

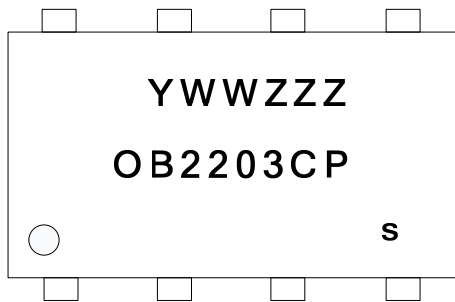

Y: Year Code
 WW: Week Code (01-52)
 ZZZ: Lot Code
 C: SOP8
 P:Pb-free Package
 s: Internal Code(Optional)

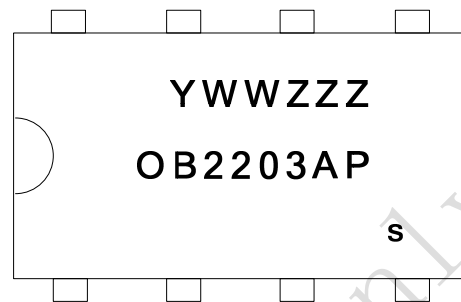

Y: Year Code
 WW: Week Code (01-52)
 ZZZ: Lot Code
 A: DIP8
 P:Pb-free Package
 s: Internal Code(Optional)

TERMINAL ASSIGNMENTS

Pin Num	Pin Name	I/O	Description
1	SS	I/O	Multi-functional pin. One function is for soft-start programming by connecting a capacitor from SS to GND. Another function is for external latch triggering by pulling SS up to a voltage higher than 3.8V.
2	FB	I/O	Feedback input pin. PWM duty cycle is determined by voltage level into this pin and current-sense signal level at Pin 3. The voltage level at this pin also controls the mode of operation in one of the three modes: quasi-resonant (QR), pulse frequency modulation mode (PFM) and burst mode (BM).
3	CS	I	Current sense input.
4	GND	O	Ground for internal circuitry.
5	GATE	O	Totem-pole gate drive output for power MOSFET.
6	VCC	P	Chip DC power supply pin.
7	PFCVCC	P	This pin is a direct connection to the VCC pin via a low impedance switch. During standby or startup sequence, the switch is off and PFCVCC is shut down. As soon as the auxiliary winding is stabilized, PFCVCC connects to the VCC pin and provides power supply to PFC controller. It goes down in any fault or at No/Light load conditions.
8	DEM	I/O	Transformer core demagnetization detection pin. This pin is also used for output over voltage protection (OVP).

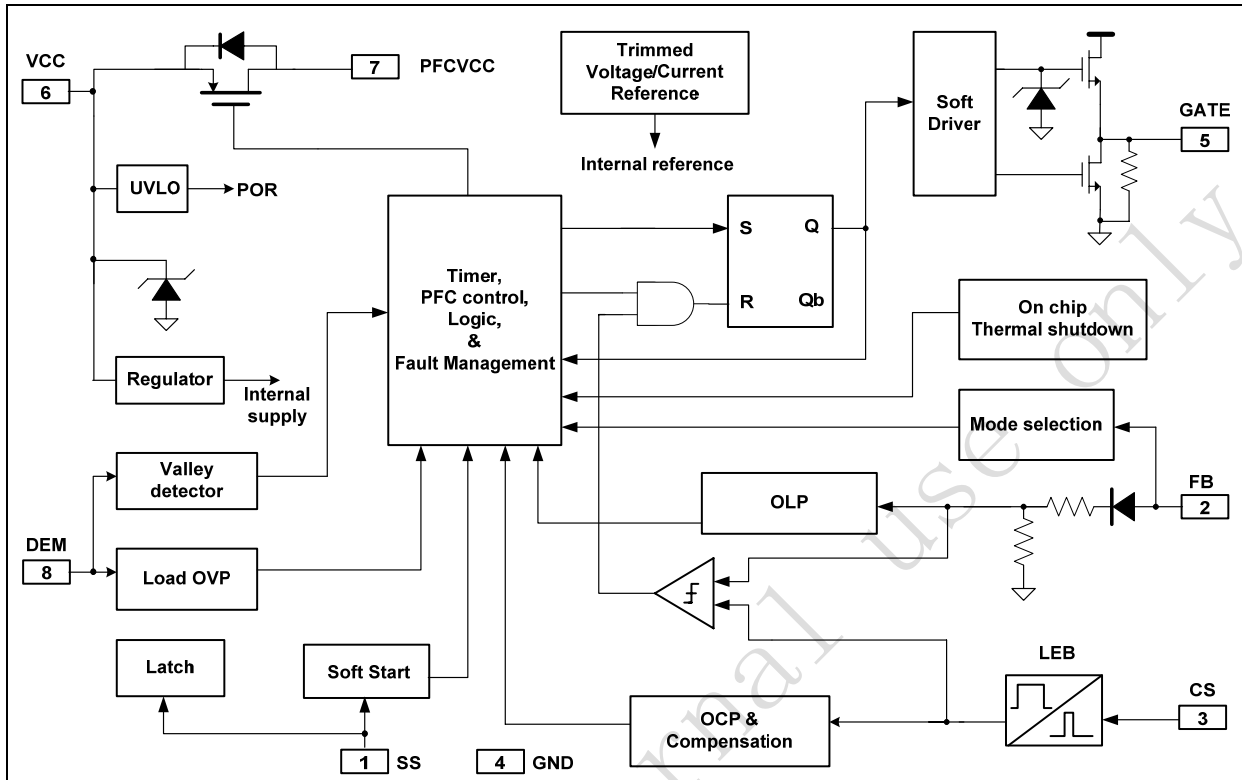
BLOCK DIAGRAM

RECOMMENDED OPERATING CONDITION

Symbol	Parameter	Min	Max	Unit
VCC	VCC Supply Voltage	12	28	V
T _A	Operating Ambient Temperature	-20	85	°C

ELECTRICAL CHARACTERISTICS

 (T_A = 25°C, VCC=18V, if not otherwise noted)

Symbol	Parameter	Test Conditions	Min	Typ	Max	Unit
Supply Voltage Section (VCC Pin)						
I_VCC_Startup	VCC Start up Current	VCC =UVLO(OFF)-1.5V, Measure current into VCC	-	5	15	uA
I_VCC_quiet	Operation Current without switching	FB=3V	-	2.0	4	mA
I_VCC_operation	Operation current with switching	FB=3V, 1nF load at GATE	-	3.0	4.5	mA
UVLO(ON)	VCC Under Voltage Lockout Enter		7.8	8.8	9.8	V
UVLO(OFF)	VCC Under Voltage Lockout Exit (Startup)		14.8	15.8	16.8	V
OVP(ON)	VCC Over Voltage Protection Enter		-	33	-	V
VCC_Clamp	VCC Zener Clamp Voltage	I(VCC) = 5 mA	-	34	-	V
Feedback Input Section (FB Pin)						
A _{VCS}	PWM Input Gain	$\Delta V_{FB} / \Delta V_{CS}$	-	3.5	-	V/V
V _{FB_Open}	FB Open Voltage		-	5.3	-	V
I _{FB_Short}	FB pin short circuit current	Short FB pin to GND, measure current	-	1.5	-	mA
V _{TH_PFM_on}	PFM mode on threshold		-	1.2	-	V
V _{TH_PFM_off}	PFM mode off threshold		-	1.1	-	V
V _{TH_BM_on}	Burst Mode on threshold		-	0.75	-	V
V _{TH_BM_off}	Burst Mode off threshold		-	0.65	-	V
V _{TH_PFC_GTS}	Threshold for PFC to go to standby		-	1	-	V
V _{TH_PFC_on}	Threshold for PFC to leave standby mode		-	1.1	-	V
V _{TH_PL}	Power Limiting FB Threshold Voltage		-	4.4	-	V
T _{D_PL}	Power limiting Debounce Time		-	80	-	mSec
Z _{FB_IN}	Input Impedance		-	4	-	Kohm
Current Sense Input Section (CS Pin)						
T _{blanking}	CS Input Leading Edge Blanking Time		-	350	-	nSec
V _{TH_OCP_zero_ontime}	Internal current limiting threshold	@ Zero switching on time	0.43	0.45	0.47	V
V _{TH_OCP_max}	Internal current limiting threshold	@ Max. switching on time	-	0.80	-	V

T _{D_OC}	Over Current Detection and Control Delay	CL=1nf at GATE	-	100	-	nSec
Demagnetization Detection Section (DEM Pin)						
V _{TH_DEM}	Demagnetization comparator threshold voltage		10	75	150	mV
V _{TH_DEM_hyst}	Hysteresis for DEM comparator		-	20	-	mV
V _{DEM_clamp(neg)}	Negative clamp voltage		-	-0.7	-	V
V _{DEM_clamp(pos)}	Positive clamp voltage		-	5.8	-	V
T _{supp}	Suppression of the transformer ringing at start of secondary stroke		-	2	-	usec
T _{OUT}	Timeout after last demag transition		-	5	-	usec
T _{DEM_delay}	Demag propagation delay		-	300	-	nsec
V _{TH_OVP}	Output OVP trigger point		-	3.75	-	V
T _{OVP_delay}	Output deglitch OVP time constant		-	4	-	Switching Cycle
Soft Start Section (SS Pin)						
I _{ss}	Soft start charge current		8	10	12	uA
V _{TH_ss_exit}	Soft start termination threshold		-	2.2	-	V
I _{ss_clamp_sink}	Maximum sink current capability when SS is clamped		-	120	-	uA
V _{SS_clamp}	SS pin high clamp voltage		-	5.8	-	V
Timer Section						
F _{burst}	Burst mode switching frequency		-	22	-	KHz
F _{QR_clamp_h}	Frequency high clamp in QR mode		117	130	143	KHz
T _{on_max}	Maximum on time		16	21	26	usec
T _{off_max}	Maximum off time		63	93	123	usec
G _{PFM}	PFM mode frequency modulation slope versus control voltage		-	240	-	KHz/V
Thermal Protection						
T _{shutdown}	Thermal shutdown temperature		-	140	-	°C

Latch Protection						
V_latch_trigger	Latch trigger threshold voltage at SS pin	SS pin pull up current should be larger than 200uA	-	3.8	-	V
V_latch_release	VCC latch release voltage		-	6.3	-	V
Ivdd(latch)	VCC current when latch off	VCC=V_latch_release+1V	-	45	-	uA
PFC ON/OFF Section (PFCVCC Pin)						
Rdson	On-resistance of PMOS switch		-	20	-	Ω
T_PFC_GTS	PFC go to standby debounce time		-	125	-	ms
Gate Drive Output (GATE Pin)						
VOL	Output Low Level	I _o = 100 mA (sink)	-	-	1	V
VOH	Output High Level	I _o = 100 mA (source), VCC=20V	7.5	-	-	V
VG_Clamp	Output Clamp Voltage Level	VCC=20V	-	16.5	-	V
T _r	Output Rising Time	CL = 1nf	-	50	-	nSec
T _f	Output Falling Time	CL = 1nf	-	20	-	nSec

CHARACTERIZATION PLOTS

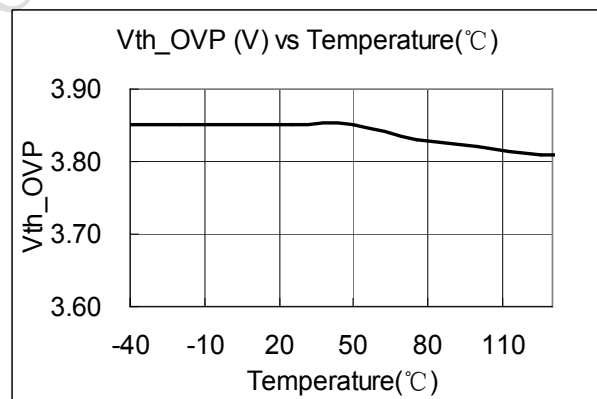
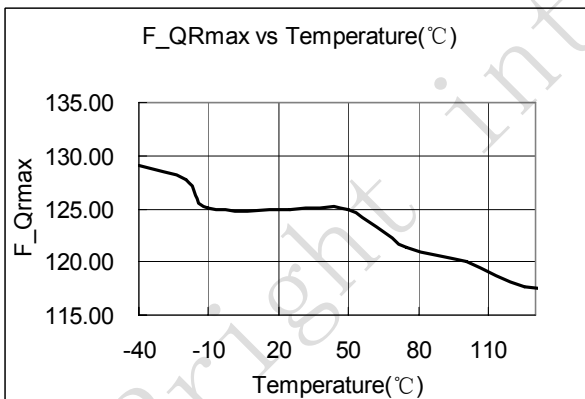
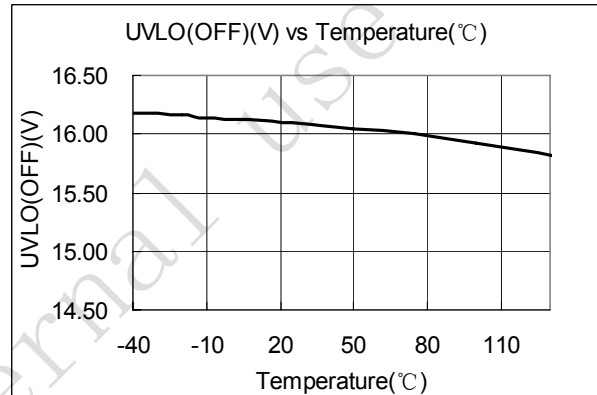
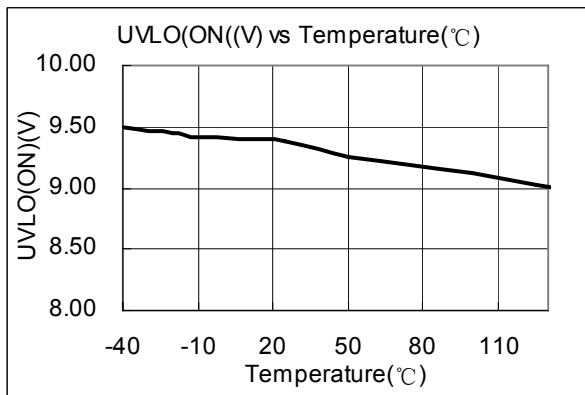
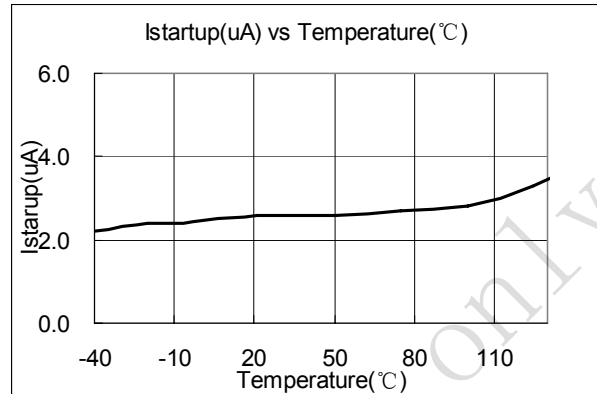
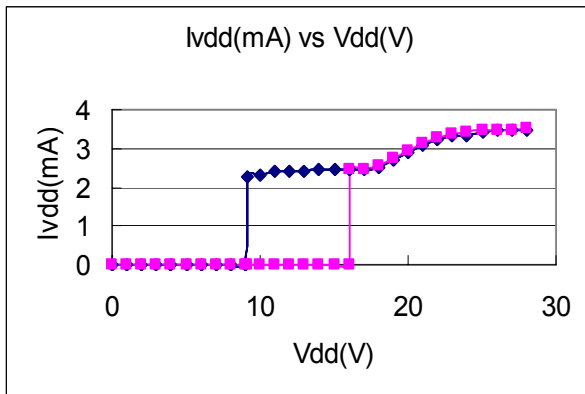

OPERATION DESCRIPTION

Quasi-Resonant (QR) converter typically features lower EMI and higher power conversion efficiency compared to conventional hard-switched converter with a fixed switching frequency. OB2203 is a highly integrated QR controller optimized for offline flyback converter applications. The built-in advanced energy saving with high level protection features provide cost effective solutions for energy efficient power supplies.

● Startup Current and Start up Control

Startup current of OB2203 is designed to be very low so that VCC could be charged up above UVLO(OFF) threshold level and device starts up quickly. A large value startup resistor can therefore be used to minimize the power loss yet reliable startup in application. For a typical AC/DC adaptor with universal input range design, a 2 MΩ, 1/8 W startup resistor could be used together with a VCC capacitor to provide a fast startup and yet low power dissipation design solution.

● Operating Current

The operating current of OB2203 is as low as 3mA. Good efficiency is achieved by the low operating current together with extended burst mode control schemes at No/light load conditions.

● Multi-Mode Operation for High Efficiency

OB2203 is a multi-mode QR controller. The controller changes the mode of operation according to FB voltage, which reflects the line and load conditions.

■ Under normal operating conditions ($FB > V_{th2}$, Figure 1), the system operates in QR mode. The frequency varies depending on the line voltage and the load conditions. Therefore, the system may actually work in DCM when 130KHz frequency clamping is reached. System design should be optimized such that the operation frequency is within the range specified at full load conditions and in universal AC line input range.

■ At light load condition ($V_{th1} < V_{FB} < V_{th2}$, Figure 1), the system operates in PFM (pulse frequency modulation) mode for high power conversion efficiency. In PFM mode, the “ON” time in a switching cycle is fixed and the system modulates the frequency according to the load conditions. Generally, in flyback converter, the decreasing of load results in voltage level decreasing at FB pin. The controller monitors the voltage level at FB

and control the switching frequency. However, the valley switching characteristic is still preserved in PFM mode. That is, when load decreases, the system automatically skip more and more valleys and the switching frequency is thus reduced. In such way, a smooth frequency foldback is realized and high power conversion efficiency is achieved.

■ At zero load or very light load conditions ($V_{FB} < V_{th1}$), the system operates in On-Bright’s proprietary “extended burst mode”. In this condition, voltage at FB is below burst mode threshold level, V_{th1} . The Gate drive output switches only when VCC voltage drops below a preset level or FB input is active to output an on state. Otherwise the gate drive remains at off state to minimize the switching loss thus reduce the standby power consumption to the greatest extend. In extended burst mode, the switching frequency is fixed to 22KHz, in this way, possible audio noise is eliminated.

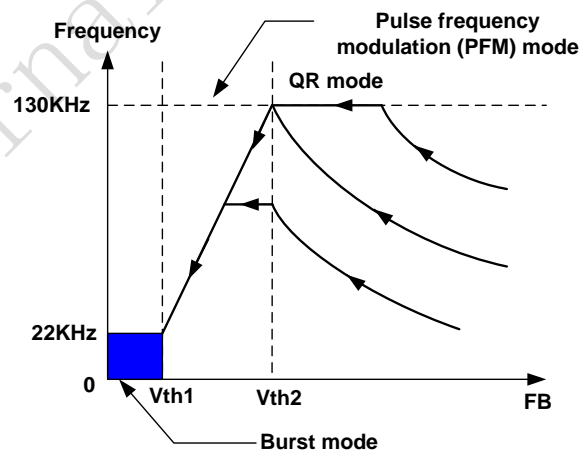

Figure 1

● Demagnetization Detection

The transformer core demagnetization is detected by monitoring the voltage activity on the auxiliary windings through DEM pin. This voltage features a flyback polarity. A new cycle starts when the power switch is activated. After the on time (determined by the CS voltage and FB), the switch is off and the flyback stroke starts. After the flyback stroke, the drain voltage shows an oscillation with a frequency of approximately $1/2\pi\sqrt{L_p C_d}$, where L_p is the primary self inductance of the transformer and C_d is the capacitance on the drain node.

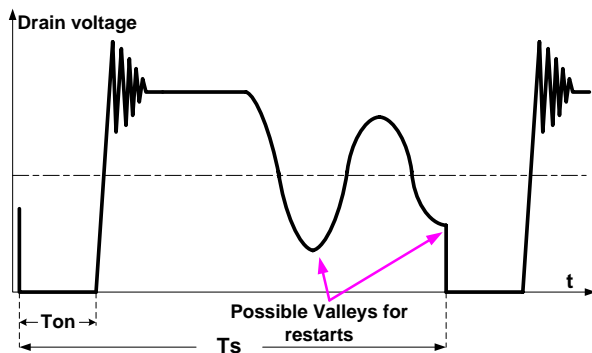

Figure 2

The typical detection level is fixed at 75mV at the DEM pin. Demagnetization is recognized by detection of a possible “valley” when the voltage at DEM is below 75mV in falling edge. DEM detection is suppressed during the ringing suppression time T_{supp} (please refer to “**Ringing Suppression Timer**” section).

- **Current Sensing and Leading Edge Blanking**

Cycle-by-Cycle current limiting is offered in OB2203 current mode control. The switch current is detected by a sense resistor into the CS pin. An internal leading edge blanking circuit chops off the sense voltage spike at initial MOSFET on state due to snubber diode reverse recovery so that the external RC filtering on sense input is no longer needed. The current limit comparator is disabled and cannot turn off the external MOSFET during the blanking period. The PWM duty cycle is determined by the current sense input voltage and the FB input voltage. In addition, built-in CS pin floating protection is provided.

- **Maximum and Minimum On-Time**

The minimum on-time of the system is determined by the LEB time (typical 350ns). The IC limits the on-time to a maximum time of 21us

- **Ringing Suppression Timer**

A ringing suppression timer T_{supp} is implemented in OB2203. In normal operation, T_{supp} starts when CS reaches the feedback voltage FB, the external power switch is set to off state. During T_{supp} , the external power switch remains in off state and cannot be turned on gain. The ringing suppression time is necessary in applications where the transformer has a large leakage inductance, particularly at low output voltages or startup. In OB2203, the ringing suppression timer T_{supp} is set to 2us internally.

- **PFC VCC Power On/Off Control**

In medium to large power applications, PFC pre-converter is required and PFC controller is powered by PWM auxiliary power supply. In OB2203, PFCVCC pin is directly connected to VCC pin by an internal low impedance power switch, thus no external components are needed. PFCVCC is shut down in any of the following conditions: any fault condition, No load/light load condition, soft start sequence.

- **Maximum Frequency Clamp**

According to the QR operation principle, the switching frequency is inversely proportional to the output power. Therefore, when the output power decreases, the switching frequency can become rather high without limiting. To meet the CISPR-22 EMI limit starting at 150KHz, the maximum switching frequency in OB2203 is internally limited to 130KHz.

- **On chip Thermal Shutdown**

OB2203 provides an on chip thermal shutdown. The IC will stop switching when the junction temperature exceeds the thermal shutdown temperature, typically 140 °C.

- **External Latch Triggering**

By externally forcing a level on pin SS (e.g., with a signal coming from a temperature sensor) greater than 3.8V, OB2203 can be permanently latched-off. To resume normal operation, VCC voltage should go below 6.3V(typical), which implies to unplug the SMPS from the mains.

- **OCP Compensation**

OB2203 is recommended to be used in applications with PFC pre-regulation stage. In some situations, the input voltage (i.e., the output voltage of PFC pre-regulator) to the QR stage is not kept constant in the entire AC line input range, for example, if PFC has a dual output voltage for performance optimization. In such applications, the OCP point is not constant anymore. In OB2203, a proprietary OCP compensation block is integrated and no external components are needed. The OCP threshold in OB2203 is a function of the switching ON time. For the ON time less than 15us, the OCP threshold changes linearly from 0.45V to 0.8V. For the ON time larger than 15us, the OCP threshold is clamped to 0.8V, as shown in Fig.3.

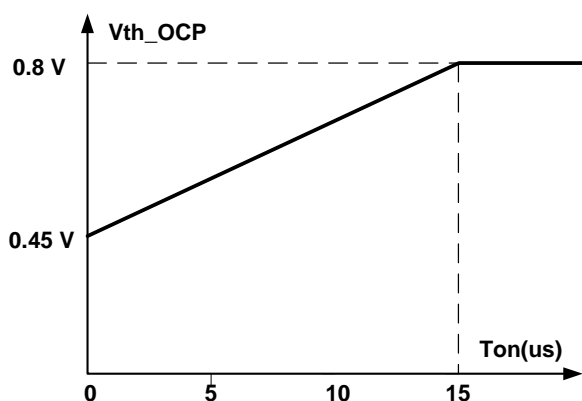

Figure 3

● Output Over Voltage Protection (OVP)

An output over voltage protection (OVP) is implemented by sensing the auxiliary winding voltage at DEM pin during the flyback phase. The auxiliary winding voltage is a well-defined replica of the output voltage. The OVP works by sampling the plateau voltage at DEM pin during the flyback phase. A 2 us internal delay (plateau sampling) guarantees a clean plateau, provided that the leakage inductance ringing has been fully damped.

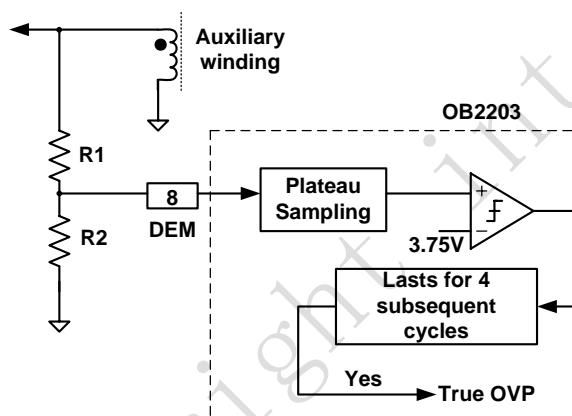

Figure 4

If the sampled plateau voltage exceeds the OVP trip level (3.75V), an internal counter starts counting subsequent OVP events. If OVP events are detected in successive 4 cycles, the controller assumes a true OVP and it enters a latch off mode and stops all switching operations. The counter has been added to prevent incorrect OVP detection which might occur during ESD or lightning events. If the output voltage exceeds the OVP trip level less than 4 successive cycles, the internal counter will be cleared and no fault is asserted.

● Overload Operation

When over load (for example, short circuit) occurs, the feedback current of photo coupler is below minimum value, FB pin voltage approaches its floating pin voltage, then a fault is detected. If this fault is present for more than 80ms, the controller enters an auto-recovery soft burst mode. All pulses are stopped, VCC will drop below UVLO and the controller will try to restart with the power on soft start. It resumes operation once the fault disappears.

● Programmable Soft Start

OB2203 features a programmable soft start to soften the constraints in the power supply during the startup. It is activated during the power on sequence. As soon as VCC reaches UVLO(OFF), an internal trimmed 10uA current is sourced from SS pin and charges the external programming capacitor, the peak current of CS pin is then gradually increased from zero. When SS pin reaches 2.2V, soft start process is over. After soft start process is over, SS pin is clamped to 2V. Every restart attempt is followed by soft start sequence.

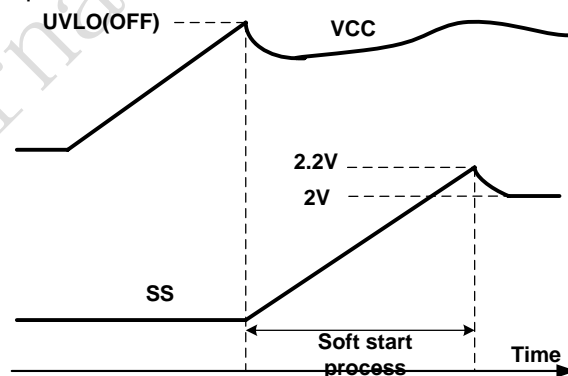

Figure 5

SS pin is also used for external latch triggering (Please refer to “**External Latch Triggering**” section).

● Gate Drive

The GATE pin is connected to the gate of an external MOSFET for power switch control. Too weak the gate drive results in higher conduction and switch loss of MOSFET while too strong gate drive output compromises the EMI. Good tradeoff is achieved through the built-in totem pole gate drive design with right output strength and dead time control. The low idle loss and good EMI system design is easier to achieve with this dedicated control scheme. An internal 16.5V clamp is added for MOSFET gate protection at high VCC voltage.

PACKAGE MECHANICAL DATA

8-Pin Plastic DIP

DIP8 PACKAGE OUTLINE DIMENSIONS

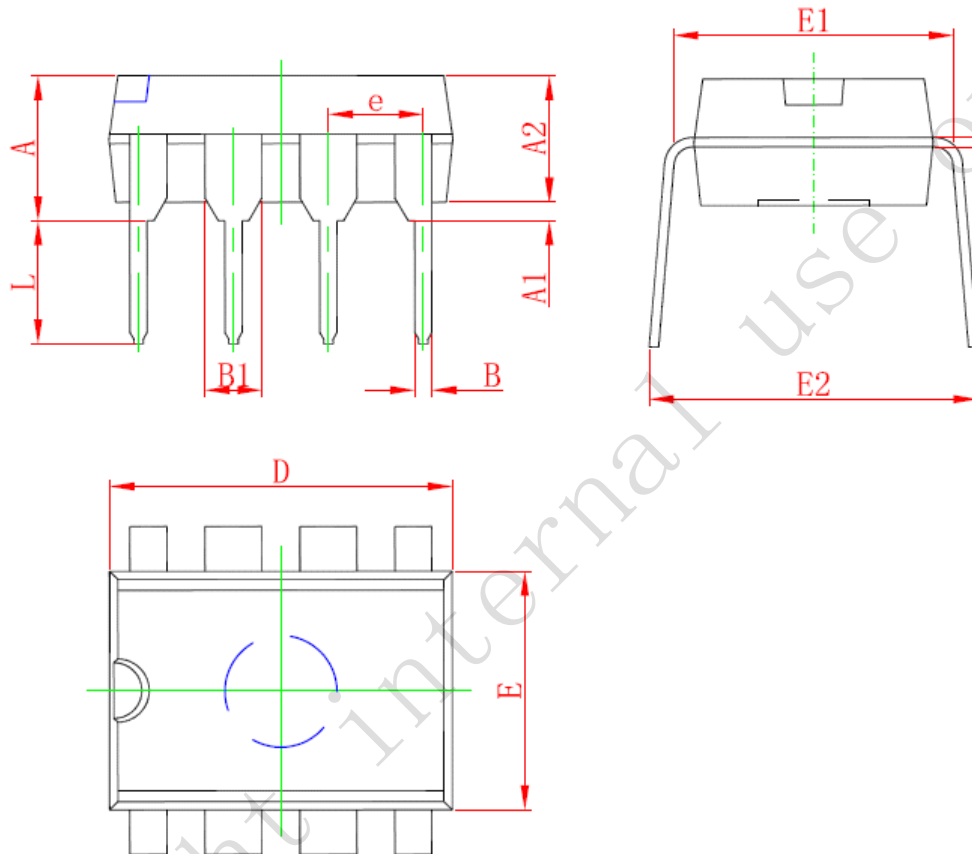

Symbol	Dimensions In Millimeters		Dimensions In Inches	
	Min	Max	Min	Max
A	3.710	5.334	0.146	0.21
A1	0.381		0.015	
A2	3.175	3.600	0.125	0.142
B	0.350	0.650	0.014	0.026
B1	1.524 (BSC)		0.06 (BSC)	
C	0.200	0.360	0.008	0.014
D	9.000	10.160	0.354	0.4
E	6.200	6.600	0.244	0.260
E1	7.320	7.920	0.288	0.312
e	2.540 (BSC)		0.1 (BSC)	
L	2.921	3.810	0.115	0.15
E2	8.200	9.525	0.323	0.375

8-Pin Plastic SOP

SOP8 PACKAGE OUTLINE DIMENSIONS

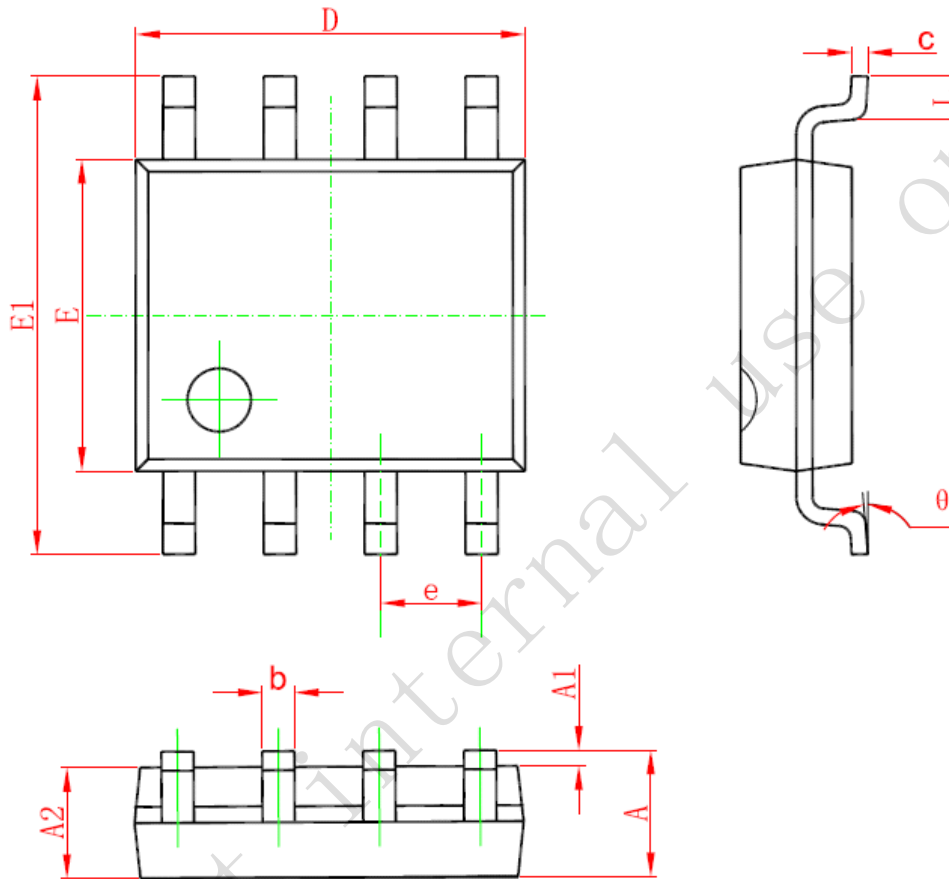

Symbol	Dimensions In Millimeters		Dimensions In Inches	
	Min	Max	Min	Max
A	1.350	1.750	0.053	0.069
A1	0.050	0.250	0.002	0.010
A2	1.250	1.650	0.049	0.065
b	0.310	0.510	0.012	0.020
c	0.170	0.250	0.006	0.010
D	4.700	5.150	0.185	0.203
E	3.800	4.000	0.150	0.157
E1	5.800	6.200	0.228	0.244
e	1.270 (BSC)		0.05 (BSC)	
L	0.400	1.270	0.016	0.050
theta	0°	8°	0°	8°

IMPORTANT NOTICE

RIGHT TO MAKE CHANGES

On-Bright Electronics Corp. reserves the right to make corrections, modifications, enhancements, improvements and other changes to its products and services at any time and to discontinue any product or service without notice. Customers should obtain the latest relevant information before placing orders and should verify that such information is current and complete.

WARRANTY INFORMATION

On-Bright Electronics Corp. warrants performance of its hardware products to the specifications applicable at the time of sale in accordance with its standard warranty. Testing and other quality control techniques are used to the extent it deems necessary to support this warranty. Except where mandated by government requirements, testing of all parameters of each product is not necessarily performed. On-Bright Electronics Corp. assumes no liability for application assistance or customer product design. Customers are responsible for their products and applications using On-Bright's components, data sheet and application notes. To minimize the risks associated with customer products and applications, customers should provide adequate design and operating safeguards.

LIFE SUPPORT

On-Bright Electronics Corp.'s products are not designed to be used as components in devices intended to support or sustain human life. On-bright Electronics Corp. will not be held liable for any damages or claims resulting from the use of its products in medical applications.

MILITARY

On-Bright Electronics Corp.'s products are not designed for use in military applications. On-Bright Electronics Corp. will not be held liable for any damages or claims resulting from the use of its products in military applications.