





## 2. PAM2421 General Description

The PAM2421 devices are high-performance, fixed frequency, current-mode PWM step-up DC/DC converter that incorporate internal power MOSFET. The PAM2421 includes an integrated power MOSFET that supports peak currents of up to 3A.

The PAM2421 utilizes simple external loop compensation allowing optimization between component size, cost, and AC performance across a wide range of applications. Additional functions include an externally programmable soft-start function for easy inrush current control, internal over-voltage protection (OVP), cycle-by-cycle current limit protection, under voltage lock-out and thermal shutdown.

The PAM2421 is available in the small SOP-8(EP) package.

## 3. Key Features

- Greater than 90% Efficiency
- Adjustable Output Voltage Up to 24V
- Internal 24V Power MOSFET
- 520kHz Frequency
- Built-in Over Voltage Protection (OVP)
- Open Protection
- Programmable Soft Start Function
- Thermal Shutdown
- Under Voltage Lockout
- Over Current Protection
- SOP-8 (EP) Package

---

DO NOT DISTRIBUTE OR REPRODUCE WITHOUT PERMISSION FROM P.A.M

**Power Analog Microelectronics, Inc.**

Rev. V1.0  
Sep., 2011



# PAM2421 EVB User Guide

CONFIDENTIAL INFORMATION

## 4. EV Board Schematic

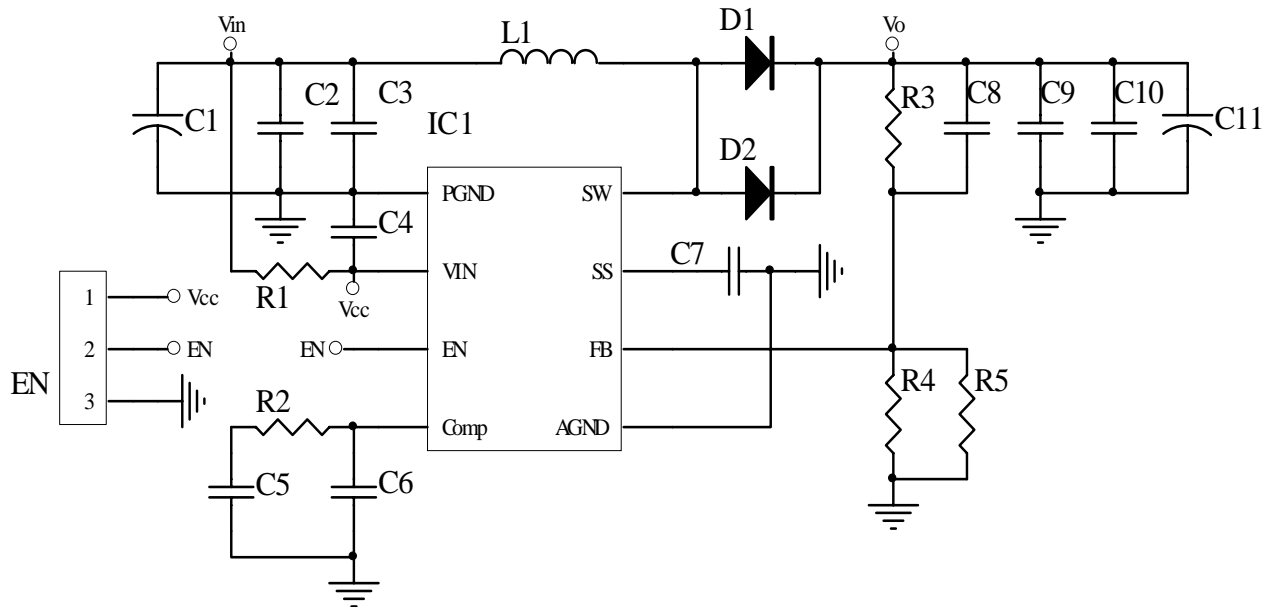

## 5. EVB PAM2421 TB15AA Description

PAM2421 TB15AA is an evaluation board for the PAM2421, a DC/DC boost converter. The board is targeted to be used in providing a simple and convenient evaluation environment for the PAM2421. Requires parts, power supply connectors etc. on the board, which makes it easy to be evaluated.

DO NOT DISTRIBUTE OR REPRODUCE WITHOUT PERMISSION FROM P.A.M

Power Analog Microelectronics, Inc.

Rev. V1.0  
Sep., 2011



# PAM2421 EVB User Guide

CONFIDENTIAL INFORMATION

## 6. EV Board View

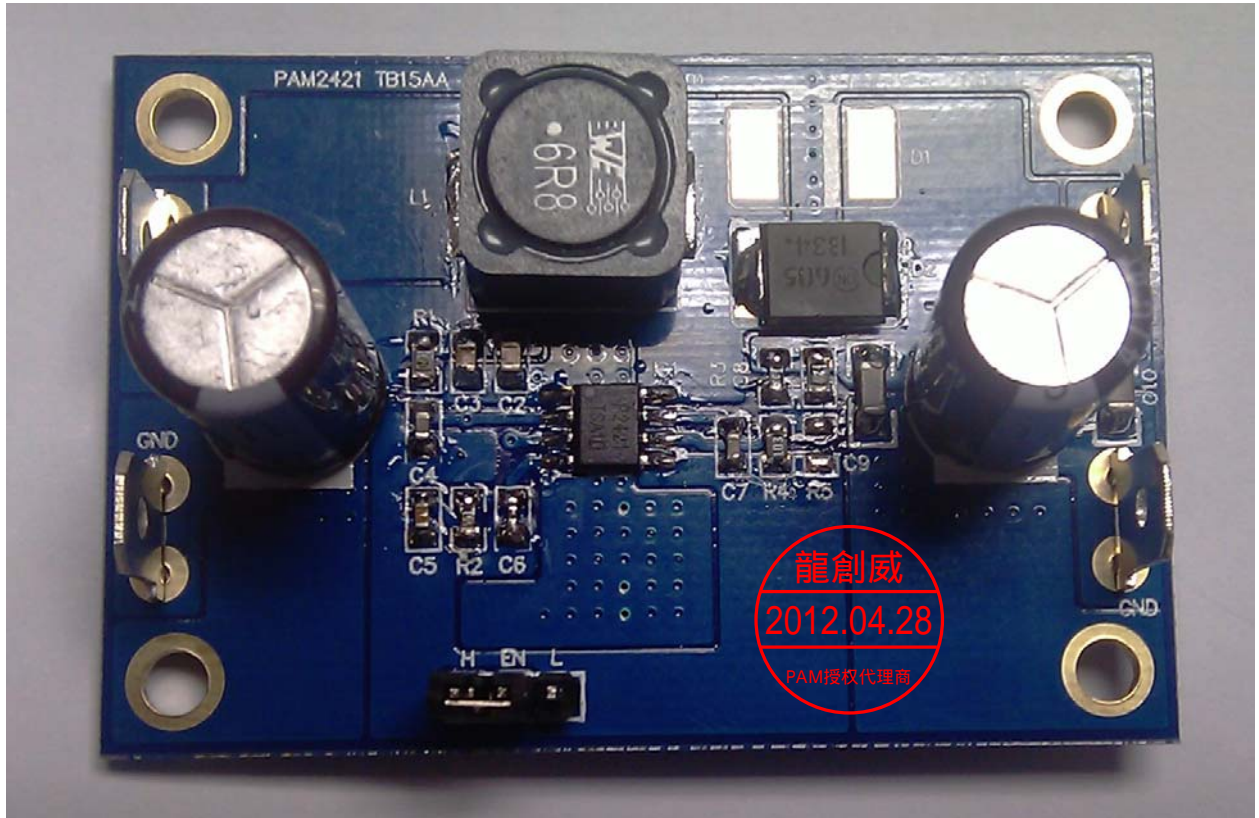

EV board operational sequence:

- Connect EN to high (H side).
- Connect load to output terminal.
- Connect Vin and GND to power supply. Vin=5V or Li-ion battery.

DO NOT DISTRIBUTE OR REPRODUCE WITHOUT PERMISSION FROM P.A.M

Power Analog Microelectronics, Inc.

Rev. V1.0  
Sep., 2011



## 7. External Components Selection

### Input & output Capacitors (C1, C2, C3, C9, C10, C11)

- (1) For lower output ripple, low ESR is required (C2, C3, C9, C10), Low leakage current needed, X5R/X7R ceramic recommend.
- (2) Provide large power, large capacitance electrolytic capacitor recommend parallel connection to the ceramic capacitor (C1, C11).

### Vin filter (R1, C4)

- (1) RC filter to filtering the switching noise on IC supply, 10Ω and 1uF ceramic capacitor recommend.

### Compensation net (R2, C5, C6)

- (1) R2 56kΩ, C5 2.2nF, C6 47pF recommend.

### Soft start (C7)

- (1) C7 0.1uF recommend.

### Schottky Diode (D1, D2)

- (1) SS34 3A/40V schottky diode recommend.

### Feed forward capacitor (C8)

- (1) Lower the output ripple, low leakage current needed, using according to application.

### Output Voltage programmer resistors (R3, R4, R5)

- (1) For programmer output voltage
- (2) For accurate output voltage, 1% tolerance is required.  $V_o = 1.262 * (1 + R3/R4 // R5)$ .

### Inductor (L1)

- (1) Low DCR for good efficiency
- (2) Inductance saturate current must higher than the output current



# PAM2421 EVB User Guide

CONFIDENTIAL INFORMATION

## 8. Evaluation board BOM list:

Item	Value	Type	Rating	Description	Vender and Part No.
C1, C11	470uF	Ecap D10*20mm	25V		
C2, C3	10uF	X5R/X7R, Ceramic/0805	16V	Input coupling CAP	TAIYO YUDEN EMK212ABJ106KD-T
C9, C10	10uF	X5R/X7R, Ceramic/1206	25V	Output coupling CAP,	TAIYO YUDEN TMK316BJ106KL-T
C4	1.0uF	X5R/X7R, Ceramic/0603	25V	Vin coupling CAP	TAIYO YUDEN TMK107B7105KA-T
C5	2.2nF	X5R/X7R, Ceramic/0603	50V		TAIYO YUDEN UMK107SD222KA-T
C6	47pF	C0H, Ceramic/0603	50V		TAIYO YUDEN UMK105CH470JV-F
C7	0.1uF	X5R/X7R, Ceramic/0805	50V		TAIYO YUDEN UMK212B7104KG-T
L1	6.8uH		>3A	Inductor	WURTH 7447709006
D2	3A/40V	SS34	SMC	Schottky diode	
D1	NC		SMC		
R1	10	0805	5%		
R2	56K	0805	1%		
R3	100K	0805	1%		
R4	10K	0805	1%		
R5	NC	0805	1%		
C8	620K	0805	1%		
IC1		PAM2421	PSOP-8		
PCB		PAM2421 TB15AA			

DO NOT DISTRIBUTE OR REPRODUCE WITHOUT PERMISSION FROM P.A.M

Power Analog Microelectronics, Inc.

Rev. V1.0  
Sep., 2011



# PAM2421 EVB User Guide

CONFIDENTIAL INFORMATION

## 9. PCB layout Example

Top Layer

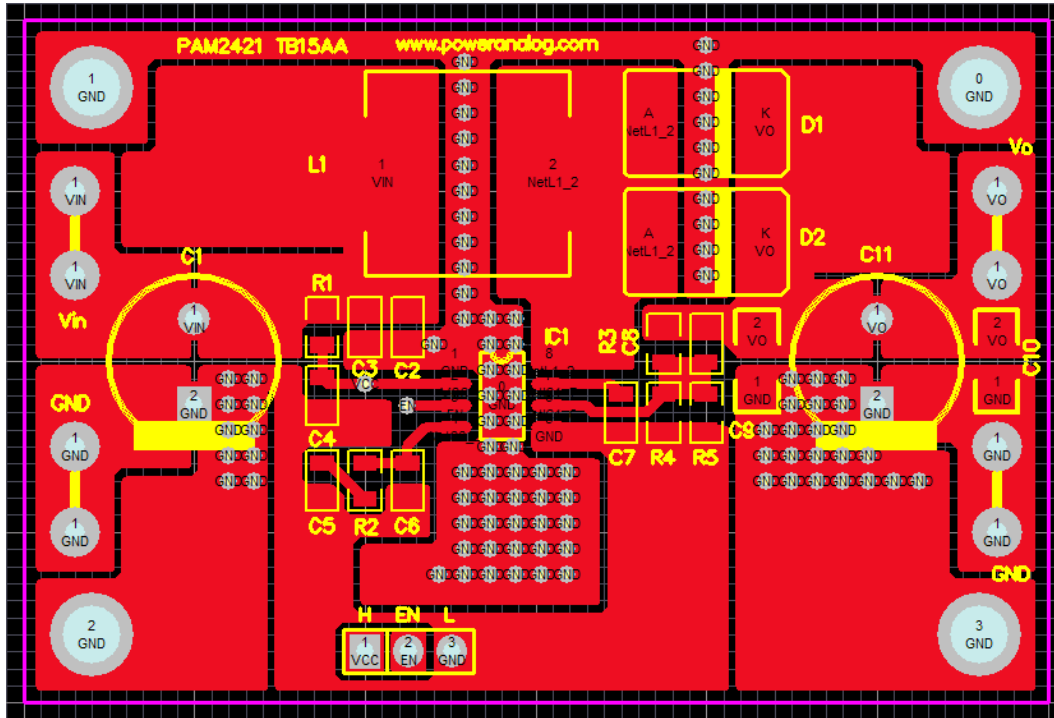

Bottom Layer

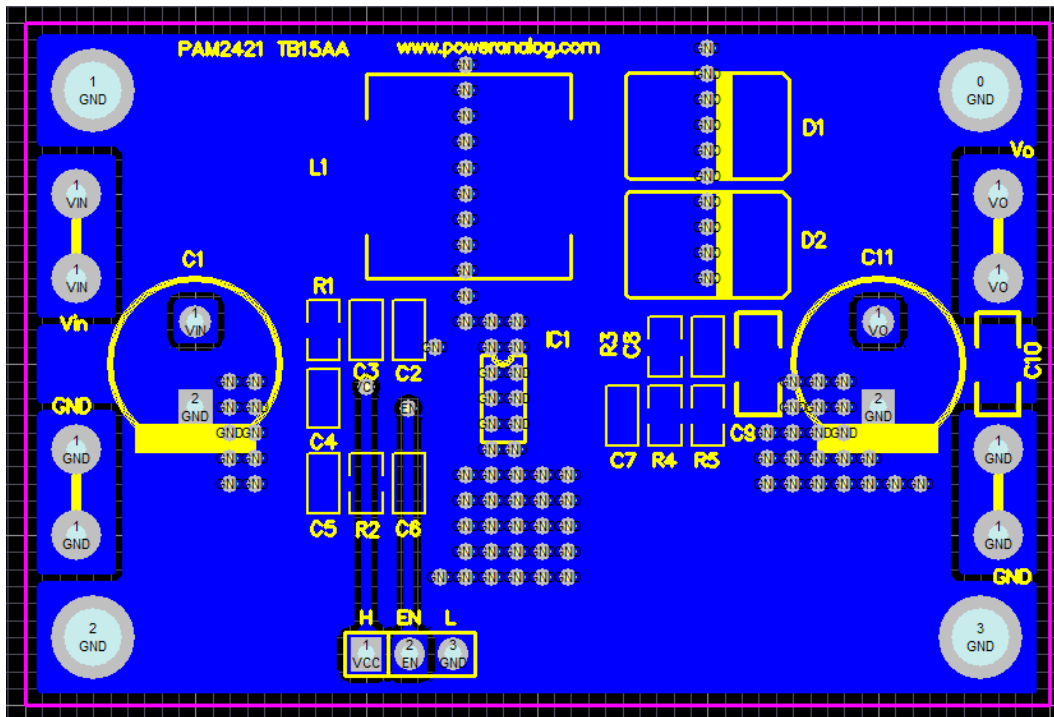

DO NOT DISTRIBUTE OR REPRODUCE WITHOUT PERMISSION FROM P.A.M

Power Analog Microelectronics, Inc.

Rev. V1.0  
Sep., 2011