



Application Notes:SY5814A

Single Stage Buck PFC Controller For LED Lighting *Preliminary datasheet*

General Description

The SY5814A is a single stage Buck PFC controller targeting at LED lighting applications. It drives the Buck converter in the quasi-resonant mode to achieve higher efficiency. It keeps the Buck converter in constant on time operation to achieve high power factor.

Ordering Information

SY5814 □(□□)□
 □ Temperature Code
 □ Package Code
 □ Optional Spec Code

Temperature Range: -40°C to 105°C

Ordering Number	Package type	Note
SY5814AABC	SOT23-6	----

Features

- Valley turn-on of the MOSFET to achieve low switching losses
- 0.3V current sense reference voltage leads to a lower sense resistance thus a lower conduction loss.
- Internal high current MOSFET driver: 0.25A sourcing and 0.5A sinking
- Low start up current: 15μA typical
- Reliable short LED and Open LED protection
- Power factor >0.90 with single-stage conversion.
- Compact package: SOT23-6

Applications

- LED lighting
- Down light
- Tube lamp
- PAR lamp
- Bulb lamp

Typical Applications

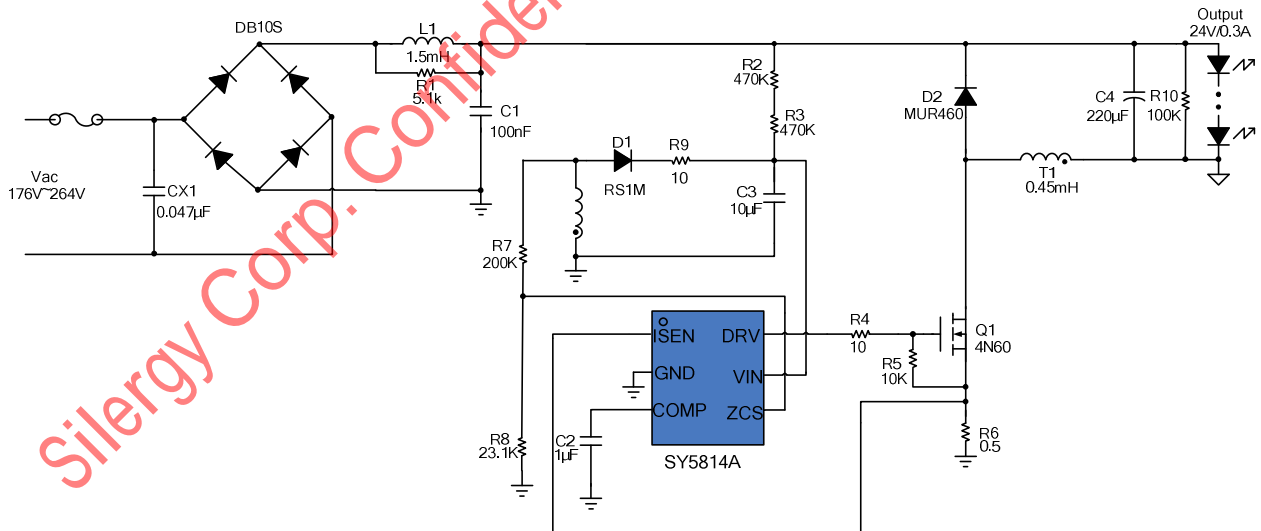
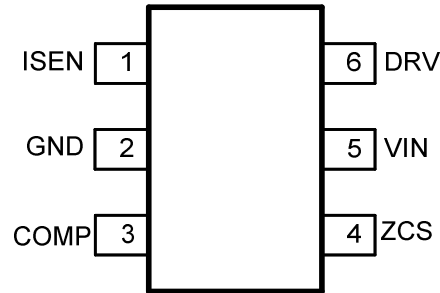

Figure 1. Schematic Diagram

Pinout (top view)



(SOT-23)

Top Mark: HHxyz for SY5814AABC(device code: HH, x=year code, y=week code, z=lot number code)

Pin Name	Pin Number	Pin Description
ISEN	1	Current sense pin. Connect this pin to the source of the switch. Connect the sense resistor across the source of the switch and the GND pin. (current sense resistor R_S : $I_o = \frac{1}{2} \times \frac{V_{REF}}{R_S}$)
GND	2	Ground pin
COMP	3	Loop compensation pin. Connect a RC network across this pin and ground to stabilize the control loop.
ZCS	4	Inductor current zero-crossing detection pin. This pin receives the auxiliary winding voltage by a resistor divider and detects the inductor current zero crossing point. This pin also provides over voltage protection and line regulation modification function simultaneously. If the voltage on this pin is above $V_{ZCS,OVp}$, the IC would enter over voltage protection mode. Good line regulation can be achieved by adjusting the upper resistor of the divider.
VIN	5	Power supply pin. This pin also provides output over voltage protection along with ZCS pin.
DRV	6	Gate drive pin. Connect this pin to the gate of MOSFET.



Absolute Maximum Ratings (Note 1)

VIN, DRV	-----	-0.3V~19V
Supply Current I _{VIN}	-----	30mA
ZCS	-----	-0.3V to VIN+0.3V
I _{SEN} , COMP	-----	3.6V
Power Dissipation, @ TA = 25°C SOT23-6	-----	0.6W
Package Thermal Resistance (Note 2)		
SOT23-6, θ _{JA}	-----	170°C/W
SOT23-6, θ _{JC}	-----	130°C/W
Maximum Junction Temperature	-----	125°C
Lead Temperature (Soldering, 10 sec.)	-----	260°C
Storage Temperature Range	-----	-65°C to 150°C

Recommended Operating Conditions (Note 3)

VIN, DRV	-----	8V~15.4V
Junction Temperature Range	-----	-40°C to 125°C
Ambient Temperature Range	-----	-40°C to 105°C

Block Diagram

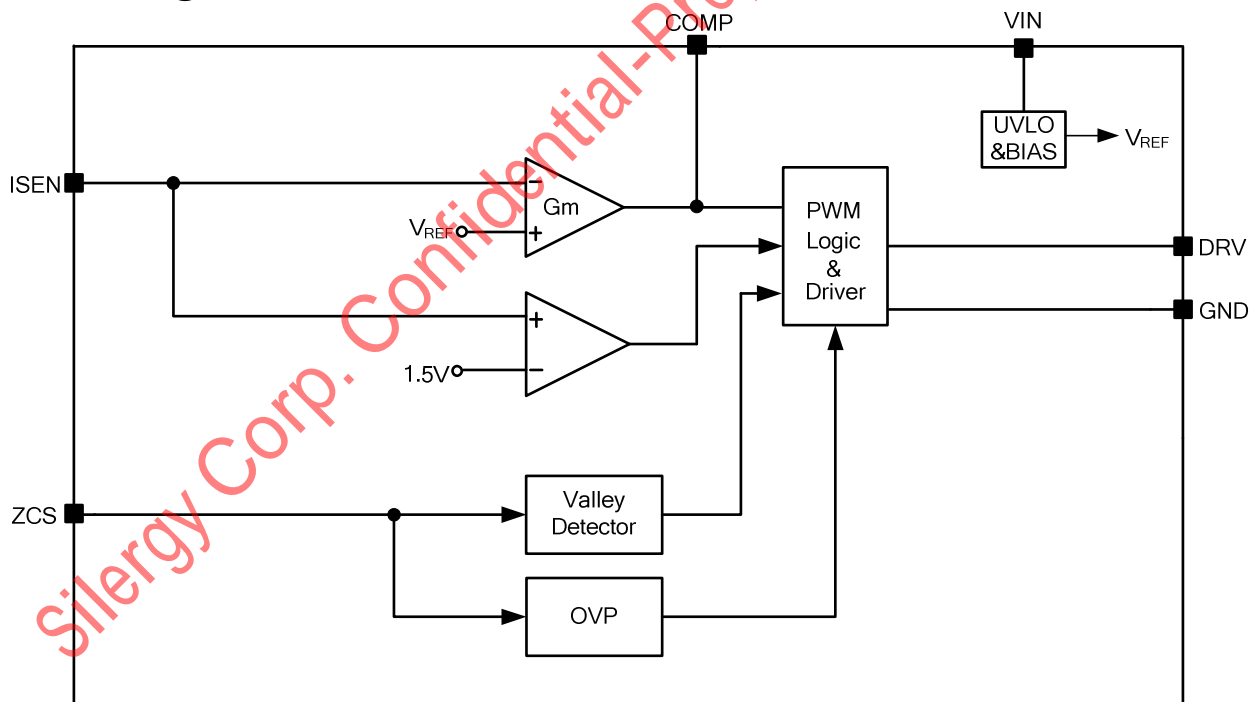



Electrical Characteristics

($V_{IN} = 12V$ (Note 3), $T_A = 25^\circ C$ unless otherwise specified)

Parameter	Symbol	Test Conditions	Min	Typ	Max	Unit
Power Supply Section						
Input voltage range	V_{VIN}		8		15.4	V
VIN turn-on threshold	$V_{VIN,ON}$				17.6	V
VIN turn-off threshold	$V_{VIN,OFF}$		6.0		7.9	V
VIN OVP voltage	$V_{VIN,OVP}$			$V_{VIN,ON}+0.85$		V
Start up Current	I_{ST}	$V_{VIN} < V_{VIN,OFF}$		15		μA
Operating Current	I_{VIN}	$C_L=100pF, f=15kHz$		1		mA
Shunt current in OVP mode	$I_{VIN,OVP}$	$V_{VIN} > V_{VIN,OVP}$	1.6	2	2.5	mA
Error Amplifier Section						
Internal reference voltage	V_{REF}		0.294	0.3	0.306	V
Current Sense Section						
Current limit reference voltage	$V_{ISEN,MAX}$			0.75		V
ZCS pin Section						
ZCS pin OVP voltage threshold	$V_{ZCS,OVP}$			1.42		V
Gate Driver Section						
Gate driver voltage	V_{Gate}			V_{VIN}		V
Maximum source current	I_{SOURCE}			0.25		A
Minimum sink current	I_{SINK}			0.5		A
Max ON Time	$T_{ON,MAX}$	$V_{COMP}=1.5V$		16		μs
Min ON Time	$T_{ON,MIN}$			400		ns
Max OFF Time	$T_{OFF,MAX}$			69		μs
Min OFF Time	$T_{OFF,MIN}$			2		μs
Maximum switching frequency	f_{MAX}			200		kHz
Thermal Section						
Thermal Shutdown Temperature	T_{SD}			150		$^\circ C$

Note 1: Stresses beyond the “Absolute Maximum Ratings” may cause permanent damage to the device. These are stress ratings only. Functional operation of the device at these or any other conditions beyond those indicated in the operational sections of the specification is not implied. Exposure to absolute maximum rating conditions for extended periods may affect device reliability.

Note 2: θ_{JA} is measured in the natural convection at $T_A = 25^\circ C$ on a low effective single layer thermal conductivity test board of JEDEC 51-3 thermal measurement standard. Test condition: Device mounted on 2” x 2” FR-4 substrate PCB, 2oz copper, with minimum recommended pad on top layer and thermal vias to bottom layer ground plane.

Note 3: Increase VIN pin voltage gradually higher than $V_{VIN,ON}$ voltage then turn down to 12V.

Operation

SY5814A is a constant current Buck PFC controller targeting at LED lighting applications.

High power factor is achieved by constant on-time operation mode, with which the control scheme and the circuit structure are both simple.

In order to reduce the switching losses and improve EMI performance, Quasi-Resonant switching mode is applied, which means to turn on the power MOSFET at valley of drain voltage; the start up current of SY5814A is rather small (15μA typically) to reduce the standby power loss further; the maximum switching frequency is clamped to 200kHz to reduce switching losses and improve EMI performance when the converter is operated at light load condition.

SY5814A provides reliable protections such as Short Circuit Protection (SCP), Open LED Protection (OLP), Over Temperature Protection (OTP), etc.

SY5814A is available with SOT-23 package.

Applications Information

Start up

After AC supply or DC BUS is powered on, the capacitor C_{VIN} across VIN and GND pin is charged up by BUS voltage through a start up resistor R_{ST} . Once V_{VIN} rises up to V_{VIN_ON} , the internal blocks start to work. V_{VIN} will be pulled down by internal consumption of IC until the bias supply circuit could supply enough energy to maintain V_{VIN} above V_{VIN_OFF} .

The whole start up procedure is divided into two sections shown in Fig.2. t_{STC} is the C_{VIN} charged up section, and t_{STO} is the output voltage built-up section. The start up time t_{ST} composes of t_{STC} and t_{STO} , and usually t_{STO} is much smaller than t_{STC} .

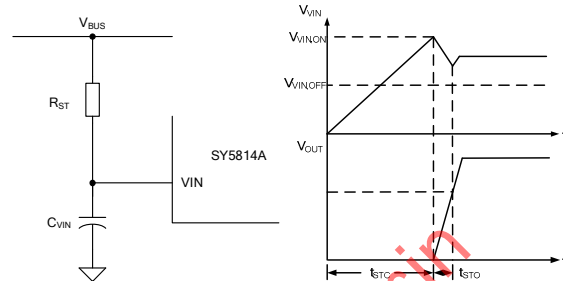

Fig.2 Start up

The start up resistor R_{ST} and C_{VIN} are designed by rules below:

- (a) Preset start-up resistor R_{ST} , make sure that the current through R_{ST} is larger than I_{ST} and smaller than I_{VIN_OVP}

$$\frac{V_{BUS}}{I_{VIN_OVP}} < R_{ST} < \frac{V_{BUS}}{I_{ST}} \quad (1)$$

Where V_{BUS} is the BUS line voltage.

- (b) Select C_{VIN} to obtain an ideal start up time t_{ST} , and ensure the output voltage is built up without another startup.

$$C_{VIN} = \frac{(\frac{V_{BUS}}{R_{ST}} - I_{ST}) \times t_{ST}}{V_{VIN_ON}} \quad (2)$$

- (c) If the C_{VIN} is not big enough to build up the output voltage at one time. Increase C_{VIN} and decrease R_{ST} , go back to step (a) and redo such design flow until the ideal start up procedure is obtained.

Internal pre-charge design for quick start up

After V_{VIN} exceeds V_{VIN_ON} , V_{COMP} is pre-charged by an internal current source. The PWM block won't start to output PWM signals until V_{COMP} is over the initial voltage V_{COMP_IC} , which can be programmed by R_{COMP} . Such design is meant to reduce the start up time shown in Fig.3.

The voltage pre-charged V_{COMP_IC} in start-up procedure can be programmed by R_{COMP}

$$V_{COMP_IC} = 600mV - 300\mu A \times R_{COMP} \quad (3)$$

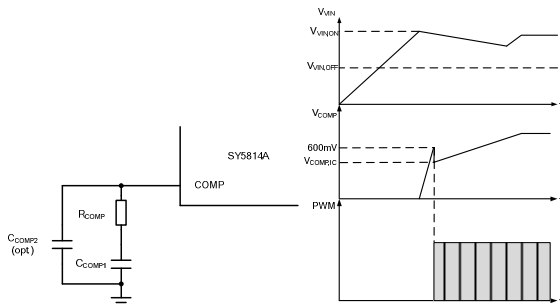

Fig.3 pre-charge scheme in start up

Where $V_{COMP-IC}$ is the pre-charged voltage of COMP pin.

Generally, a big capacitance of C_{COMP} is necessary to achieve high power factor and stabilize the system loop ($1\mu F \sim 2\mu F$ recommended); The voltage pre-charged in start-up procedure can be programmed by R_{COMP} ; On the other hand, larger R_{COMP} can provide larger phase margin for the control loop; A small ceramic capacitor C_{COMP2} is added to filter out high frequency noise ($10pF \sim 100pF$ is recommended if necessary)

Shut down

After AC supply or DC BUS is powered off, the energy stored in the BUS capacitor will be discharged. When the auxiliary winding of Buck transformer can not supply enough energy to VIN pin, V_{VIN} will drop down. Once V_{VIN} is below $V_{VIN-OFF}$, the IC will stop working and V_{COMP} will be discharged to zero.

constant-current control

The switching waveforms are shown in Fig.4.

The output current I_{OUT} can be represented by,

$$I_{OUT} = \frac{I_{PK}}{2} \times \frac{T_{dis}}{T_s} \quad (4)$$

Where I_{PK} is the peak current of the inductor. The inductor peak current I_{PK} and inductor current discharge time t_{dis} can be detected by the IC.

I_{OUT} can be represented by

$$I_{OUT} = \frac{V_{REF}}{2 \times R_S} \quad (5)$$

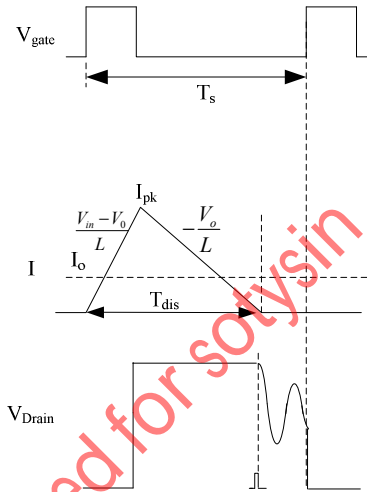

Fig.4 switching waveforms

Quasi-Resonant Operation

QR mode operation provides low turn-on switching losses for Buck converter.

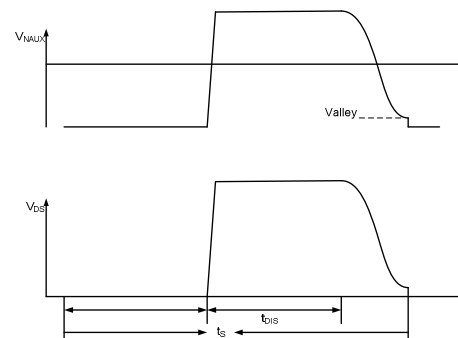

Fig.5 QR mode operation

The voltage across drain and source of the MOSFET is reflected by the auxiliary winding of the Buck transformer. ZCS pin detects the voltage across the auxiliary winding by a resistor divider. When the voltage across drain and source of the MOSFET is at voltage valley, the MOSFET would be turned on.

Over Voltage Protection (OVP) & Open LED Protection (OLP)

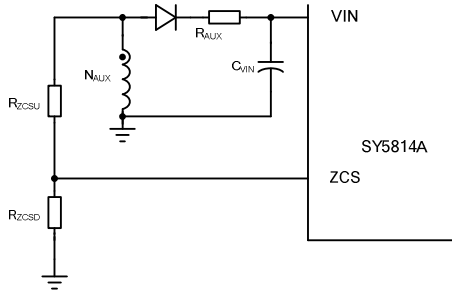

Fig.6 OVP&OLP

The output voltage is reflected by the auxiliary winding voltage of the Buck transformer, and both ZCS pin and VIN pin provide over voltage protection function. When the load is null or large transient happens, the output voltage will exceed the rated value. When V_{VIN} exceeds $V_{VIN,OV}$ or V_{ZCS} exceeds $V_{ZCS,OV}$, the over voltage protection is triggered and the IC will discharge V_{VIN} by an internal current source $I_{VIN,OV}$. Once V_{VIN} is below $V_{VIN,OFF}$, the IC will shut down and be charged again by BUS voltage through start up resistor. If the over voltage condition still exists, the system will operate in hiccup mode.

Thus, the turns of the auxiliary winding N_{AUX} and the resistor divider is related with the OVP function.

$$\frac{V_{ZCS_OV}}{V_{OV}} = \frac{N_{AUX}}{N} \times \frac{R_{ZCSD}}{R_{ZCSU} + R_{ZCSD}} \quad (6)$$

$$\frac{V_{VIN_OV}}{V_{OV}} \geq \frac{N_{AUX}}{N} \quad (7)$$

Where V_{OV} is the output over voltage specification, N and N_{AUX} are the turns of main winding and auxiliary winding separately. R_{ZCSU} and R_{ZCSD} compose the resistor divider.

The turns ratio of N to N_{AUX} and the ratio of R_{ZCSU} to R_{ZCSD} could be induced from equation (6) and (7).

Short Circuit Protection (SCP)

When the output is shorted, the output voltage is clamped to zero. The voltage of the auxiliary winding is proportional to the output winding, so V_{VIN} will drop down without auxiliary winding supply. Once V_{VIN} is below $V_{VIN,OFF}$, the IC will shut down and be charged again by the BUS voltage through the start up resistor.

If the short circuit condition still exists, the system will operate in hiccup mode.

In order to guarantee SCP function not effected by voltage spike of auxiliary winding, a filter resistor R_{AUX} is needed (10Ω typically) shown in Fig.6.

Line regulation modification

The IC provides line regulation modification function to improve line regulation performance.

Due to the sample delay of ISEN pin and other internal delay, the output current increases with increasing input BUS line voltage. A small compensation voltage ΔV_{ISEN-C} is added to ISEN pin during ON time to improve such performance. This ΔV_{ISEN-C} is adjusted by the upper resistor of the divider connected to ZCS pin.

$$\Delta V_{ISEN-C} = (V_{BUS} - V_{OUT}) \times \frac{N_{AUX}}{N} \times \frac{1}{R_{ZCSU}} \times k_3 \quad (8)$$

Where R_{ZCSU} is the upper resistor of the divider; k_3 is an internal constant as the modification coefficient.

The compensation is mainly related with R_{ZCSU} , larger compensation is achieved with smaller R_{ZCSU} . Normally, R_{ZCS} ranges from $100k\Omega \sim 1M\Omega$.

Then R_{ZCSD} can be selected by,

$$\frac{V_{ZCS_OV}}{V_{OUT}} \times \frac{N}{N_{AUX}} \times R_{ZCSU} > R_{ZCSD} \quad (9),$$

$$1 - \frac{V_{ZCS_OV}}{V_{OUT}} \times \frac{N}{N_{AUX}}$$

And,

$$R_{ZCSD} \geq \frac{\frac{V_{ZCS_OV}}{V_{OV}} \times \frac{N}{N_{AUX}}}{1 - \frac{V_{ZCS_OV}}{V_{OV}} \times \frac{N}{N_{AUX}}} \times R_{ZCSU} \quad (10)$$

Where V_{OV} is the output over voltage protection specification; V_{OUT} is the rated output voltage; R_{ZCSU} is the upper resistor of the divider; N and N_{AUX} are the turns of main winding and auxiliary winding separately.

Power Device Design

MOSFET and Diode

When the operation condition is with maximum input voltage and full load, the voltage stress of MOSFET and output power diode is maximized;

$$V_{MOS_DS_MAX} = \sqrt{2}V_{AC_MAX} \quad (11)$$

$$V_{D_R_MAX} = \sqrt{2}V_{AC_MAX} \quad (12)$$

Where V_{AC_MAX} is maximum input AC RMS voltage. When the operation condition is with minimum input voltage and full load, the current stress of MOSFET and power diode is maximized.

Inductor (L)

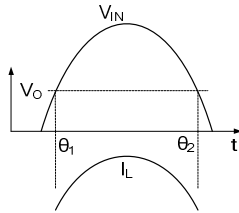

Fig.7 input waveforms

The power is transferred from AC input to output only when the input voltage is larger than output voltage in Buck converter. The input voltage and inductor current waveforms are shown in Fig.7, where θ_1 and θ_2 are the time that input voltage is equal to output voltage.

In Quasi-Resonant mode, each switching period cycle t_S consists of three parts: current rising time t_1 , current falling time t_2 and quasi-resonant time t_3 shown in Fig.8.

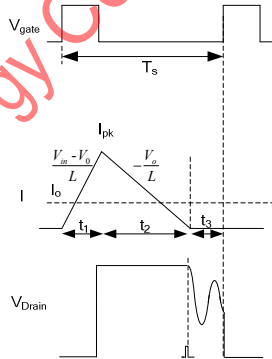

Fig.8 switching waveforms

The system operates in the constant on time mode to achieve high power factor. The ON time increases with the input AC RMS voltage decreasing and the load increasing. When the operation condition is with minimum input AC RMS voltage and full load, the ON time is maximized. On the other hand, when the input voltage is at the peak value, the OFF time is maximized. Thus, the minimum switching frequency f_{S_MIN} happens at the peak value of input voltage with minimum input AC RMS voltage and maximum load condition; Meanwhile, the maximum peak current through MOSFET and the transformer happens.

Once the minimum frequency f_{S_MIN} is set, the inductance of the transformer could be Calculated. The design flow is shown as below:

(a) Preset minimum frequency f_{S_MIN}

(b) Compute relative t_s , t_1

$$t_s = \frac{1}{f_{S_MIN}} \quad (13)$$

$$t_1 = \frac{t_s \times (V_{OUT} + V_{DF})}{(\sqrt{2}V_{AC_MIN} + V_{DF})} \quad (14)$$

$$t_2 = t_s - t_1 \quad (15)$$

Where V_{DF} is the forward voltage of the diode

(c) Design inductance L

$$\theta_1 = \arcsin\left(\frac{V_{OUT}}{\sqrt{2}V_{AC_MIN}}\right) \times \frac{1}{\pi} \times \frac{1}{2 \times f_{AC}} \quad (16)$$

$$\theta_2 = \frac{1}{2 \times f_{AC}} - \theta_1 \quad (17)$$

$$L = \frac{\eta \times f_{AC} \times V_{OUT} \times t_1}{P_{OUT}} \times \quad (18)$$

$$\left[\sqrt{2}V_{AC_MIN} \times \frac{\cos(2\pi f_{AC} \times \theta_1) - \cos(2\pi f_{AC} \times \theta_2)}{2\pi f_{AC}} - V_{OUT}(\theta_2 - \theta_1) \right]$$

Where η is the efficiency; P_{OUT} is rated full load power; θ_1 and θ_2 are

(d) compute inductor maximum peak current $I_{L_PK_MAX}$.

$$I_{L_PK_MAX} = \frac{(\sqrt{2}V_{AC_MIN} - V_{OUT}) \times t_1}{L} \quad (19)$$

Where $I_{L_PK_MAX}$ is maximum inductor peak current ;

(e) compute RMS current of the inductor

$I_{L_RMS_MAX}$ is Inductor RMS current of whole AC period

$$I_{L_RMS_MAX} = \frac{t_1}{\sqrt{3} \times L} \sqrt{V_{AC_MIN}^2 + V_{OUT}^2} - \frac{4\sqrt{2}V_{AC_MIN} \times V_{OUT}}{\pi}$$

(20)

(f) compute RMS current of the MOSFET

$$I_{L_RMS_MAX} = \sqrt{\frac{t_1}{3t_s} \times \frac{t_1}{L} \sqrt{V_{AC_MIN}^2 + V_{OUT}^2} - \frac{4\sqrt{2}V_{AC_MIN} \times V_{OUT}}{\pi}}$$

(21)

Inductor design (N, N_{AUX})

the parameters below are necessary:

Necessary parameters	
Inductance	L
inductor maximum current	I _{L-PK-MAX}
inductor maximum RMS current	I _{L-RMS-MAX}

The design rules are as followed:

(a) Select the magnetic core style, identify the effective area A_e.

(b) Preset the maximum magnetic flux ΔB

$$\Delta B = 0.22 \sim 0.26T$$

(c) Compute primary turn N

$$N = \frac{L_M \times I_{L_PK_MAX}}{\Delta B \times A_e} \quad (22)$$

(d) compute auxiliary turn N_{AUX}

$$N_{AUX} = N \times \frac{V_{VIN}}{V_{OUT}} \quad (23)$$

Where V_{VIN} is the working voltage of VIN pin (10V~11V is recommended).

(e) Select an appropriate wire diameter with I_{L-RMS-MAX}, select appropriate wire to make sure the current density ranges from 4A/mm² to 10A/mm².

(f) If the winding area of the core and bobbin is not enough, reselect the core style, go to (a) and redesign the transformer until the ideal transformer is achieved.

Output capacitor C_{OUT}

Preset the output current ripple ΔI_{OUT}, C_{OUT} is induced by

$$C_{OUT} = \frac{\sqrt{\left(\frac{2I_{OUT}}{\Delta I_{OUT}}\right)^2 - 1}}{4\pi f_{AC} R_{LED}} \quad (24)$$

Where I_{OUT} is the rated output current; ΔI_{OUT} is the demanded current ripple; f_{AC} is the input AC supply frequency; R_{LED} is the equivalent series resistor of the LED load.

Layout

(a) To achieve better EMI performance and reduce line frequency ripples, the output of the bridge rectifier should be connected to the BUS line capacitor first, then to the switching circuit.

(b) The ground of the BUS line capacitor, the ground of the current sample resistor and the signal ground of the IC should be connected in a star connection.

(c) The circuit loop of all switching circuit should be kept small: primary power loop, secondary loop and auxiliary power loop.

(d) The wire connected to ISEN and DRV should be as thick as possible.

(e) The resistor divider is recommended to be put beside the IC.

Design Example

A design example of typical application is shown below step by step.

#1. Identify design specification

Design Specification			
V _{AC} (RMS)	176V~264V	V _{OUT}	24V
I _{OUT}	300mA	η	92%

#2. Inductor design (L)

Refer to Power Device Design

Conditions			
V _{AC,MIN}	176V	V _{AC-MAX}	264V
P _{OUT}	7.2W	f _{S-MIN}	55kHz

(a) f_{S,MIN} is preset

$$f_{S_MIN} = 46\text{kHz}$$

(b) Compute the switching period t_s and ON time t₁ at the peak of input voltage.

$$t_s = \frac{1}{f_{S_MIN}} = 21.74\mu\text{s}$$

$$t_1 = \frac{t_s \times (V_{OUT} + V_{DF})}{(\sqrt{2}V_{AC_MIN} + V_{DF})} = \frac{21.74\mu\text{s} \times (24\text{V} + 1\text{V})}{(\sqrt{2} \times 176\text{V} + 1\text{V})} = 2.17\mu\text{s}$$

$$t_2 = t_s - t_1 = 21.74\mu\text{s} - 2.17\mu\text{s} = 19.57\mu\text{s}$$

(c) Compute the inductance L

$$\theta_1 = \arcsin\left(\frac{V_{OUT}}{\sqrt{2}V_{AC_MIN}}\right) \times \frac{1}{\pi} \times \frac{1}{2 \times f_{AC}} = \arcsin\left(\frac{24\text{V}}{\sqrt{2} \times 176\text{V}}\right) \times \frac{1}{\pi} \times \frac{1}{2 \times 50\text{Hz}} = 3.074 \times 10^{-4} \text{ s}$$

$$\theta_2 = \frac{1}{2 \times f_{AC}} - \theta_1 = \frac{1}{2 \times 50\text{Hz}} - 3.074 \times 10^{-4} \text{ s} = 9.693 \times 10^{-3} \text{ s}$$

$$L = \frac{\eta \times f_{AC} \times V_{OUT} \times t_1}{P_{OUT}} \times$$

$$\left[\sqrt{2}V_{AC_MIN} \times \frac{\cos(2 \times \pi \times f_{AC} \times \theta_1) - \cos(2 \times \pi \times f_{AC} \times \theta_2)}{2 \times \pi \times f_{AC}} - V_{OUT}(\theta_2 - \theta_1) \right]$$

$$= \frac{0.92 \times 50\text{Hz} \times 24\text{V} \times 2.17\mu\text{s}}{7.2\text{W}} \times$$

$$\left[\sqrt{2} \times 176\text{V} \times \frac{\cos(2\pi \times 50\text{Hz} \times 3.074 \times 10^{-4} \text{ s}) - \cos(2\pi \times 50\text{Hz} \times 9.693 \times 10^{-3} \text{ s})}{2\pi \times 50\text{Hz}} - 24\text{V}(9.693 \times 10^{-3} \text{ s} - 3.074 \times 10^{-4} \text{ s}) \right]$$

$$= 451\mu\text{H}$$

(d) compute inductor maximum peak current I_{L-PK-MAX}.

$$I_{L_PK_MAX} = \frac{(\sqrt{2}V_{AC_MIN} - V_{OUT}) \times t_1}{L} = \frac{(\sqrt{2} \times 176 - 24) \times 2.17 \mu s}{451 \mu H} = 1.082 A$$

Where $I_{L_PK_MAX}$ is maximum inductor peak current ;
 (f) compute RMS of the inductor current $I_{L_RMS_MAX}$

$$I_{L_RMS_MAX} = \frac{t_1}{\sqrt{3} \times L} \sqrt{V_{AC_MIN}^2 + V_{OUT}^2 - \frac{4\sqrt{2}V_{AC_MIN} \times V_{OUT}}{\pi}}$$

$$= \frac{2.17 \mu s}{\sqrt{3} \times 451 \mu H} \sqrt{176V^2 + 24V^2 - \frac{4\sqrt{2} \times 176V \times 24V}{\pi}}$$

$$= 0.43 A$$

#3. Select power MOSFET and power diode

Refer to Power Device Design

Known conditions at this step			
V_{AC_MAX}	264V	η	92%
V_{OUT}	24V		

Compute the voltage and the current stress of MOSFET:

$$I_{L_RMS_MAX} = \sqrt{\frac{t_1}{3t_s} \times \frac{t_1}{L} \sqrt{V_{AC_MIN}^2 + V_{OUT}^2 - \frac{4\sqrt{2}V_{AC_MIN} \times V_{OUT}}{\pi}}}$$

$$= \sqrt{\frac{2.17 \mu s}{3 \times 21.74 \mu s} \times \frac{2.17 \mu s}{451 \mu H} \times \sqrt{176V^2 + 24V^2 - \frac{4\sqrt{2} \times 176V \times 24V}{\pi}}}$$

$$= 0.136 A$$

#4. Select the output capacitor C_{OUT}

Refer to Power Device Design

Conditions			
I_{OUT}	300mA	ΔI_{OUT}	$0.3I_{OUT}$
f_{AC}	50Hz	R_{LED}	$7 \times 1.6 \Omega$

The output capacitor is



$$C_{OUT} = \frac{\sqrt{\left(\frac{2I_{OUT}}{\Delta I_{OUT}}\right)^2 - 1}}{4\pi f_{AC} R_{LED}}$$

$$= \frac{\sqrt{\left(\frac{2 \times 0.3A}{0.5 \times 0.3A}\right)^2 - 1}}{4\pi \times 50Hz \times 7 \times 1.6\Omega}$$

$$= 550\mu F$$

#6. Set VIN pin

Refer to Start up

Conditions			
V _{BUS-MIN}	176V × 1.414	V _{BUS-MAX}	264V × 1.414
I _{ST}	15μA (typical)	V _{IN-ON}	16V (typical)
I _{VIN-OVP}	2mA (typical)	t _{ST}	500ms (designed by user)

(a) R_{ST} is preset

$$R_{ST} < \frac{V_{BUS}}{I_{ST}} = \frac{176V \times 1.414}{15\mu A} = 16.59M\Omega ,$$

$$R_{ST} > \frac{V_{BUS}}{I_{VIN_OVP}} = \frac{264V \times 1.414}{2mA} = 186.7k\Omega$$

Set R_{ST}

$$R_{ST} = 470k\Omega \times 2 = 950k\Omega$$

(b) Design C_{VIN}

$$C_{VIN} = \frac{\left(\frac{V_{BUS}}{R_{ST}} - I_{ST}\right) \times t_{ST}}{V_{VIN_ON}}$$

$$= \frac{\left(\frac{176V \times 1.414}{950k\Omega} - 15\mu A\right) \times 500ms}{16V}$$

$$= 7.72\mu F$$

Set C_{VIN}

$$C_{VIN} = 10\mu F$$



#7 Set COMP pin

Refer to **Internal pre-charge design for quick start up**

Parameters designed			
R _{COMP}	500Ω	V _{COMP,IC}	600mV
C _{COMP1}	2μF	C _{COMP2}	0

#8 Set current sense resistor to achieve ideal output current

Refer to **constant-current control**

Known conditions at this step			
V _{REF}	0.3V	I _{OUT}	0.3A

The current sense resistor is

$$R_s = \frac{V_{REF}}{2 \times I_{OUT}} = \frac{0.3}{2 \times 0.3A} = 0.5\Omega$$

#9 set ZCS pin

Refer to **Line regulation modification** and **Over Voltage Protection (OVP) & Open Loop Protection (OLP)**

First identify R_{ZCSU} need for line regulation.

Known conditions at this step			
Parameters Designed			
R _{ZCSU}	200kΩ		

Then compute R_{ZCSD}

Conditions			
V _{ZCS_OVP}	1.42V	V _{OVP}	35V
V _{OUT}	24V		
Parameters designed			
R _{ZCSU}	200kΩ		
N	100	N _{AUX}	45

$$R_{ZCSD} < \frac{V_{ZCS_OVP} \times \frac{N}{N_{AUX}}}{1 - \frac{V_{ZCS_OVP}}{V_{OUT}} \times \frac{N}{N_{AUX}}} \times R_{ZCSU}$$

$$= \frac{1.42V \times \frac{100}{45}}{1 - \frac{1.42V}{24V} \times \frac{100}{45}} \times 200k\Omega$$

$$= 30.2k\Omega$$

$$R_{ZCSD} \geq \frac{\frac{V_{ZCS_OVP}}{V_{OVP}} \times \frac{N}{N_{AUX}}}{1 - \frac{V_{ZCS_OVP}}{V_{OVP}} \times \frac{N}{N_{AUX}}} \times R_{ZCSU}$$

$$= \frac{\frac{1.42V}{35V} \times \frac{100}{45}}{1 - \frac{1.42V}{35V} \times \frac{100}{45}} \times 200k\Omega$$

$$= 19.8k\Omega$$

R_{ZCSD} is set to

$$R_{ZCSD} = 22.1k\Omega$$

#10 final result

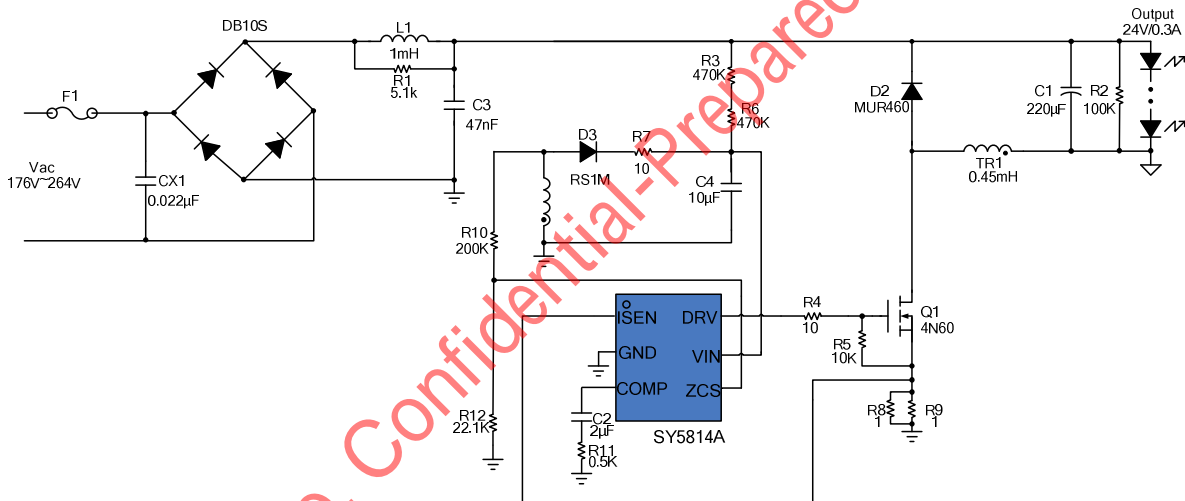

SOT23-6 Package outline & PCB layout design

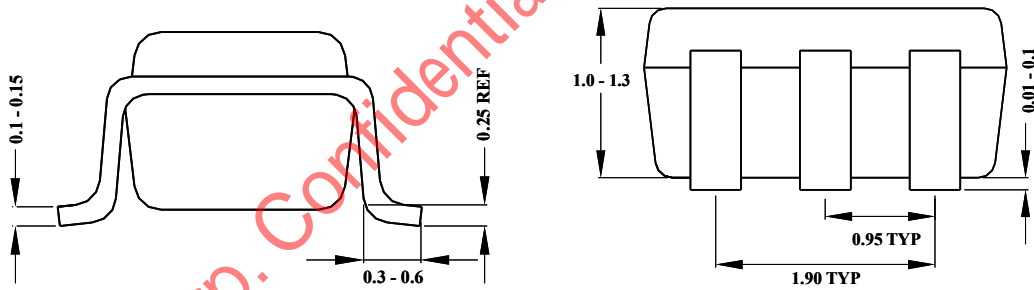
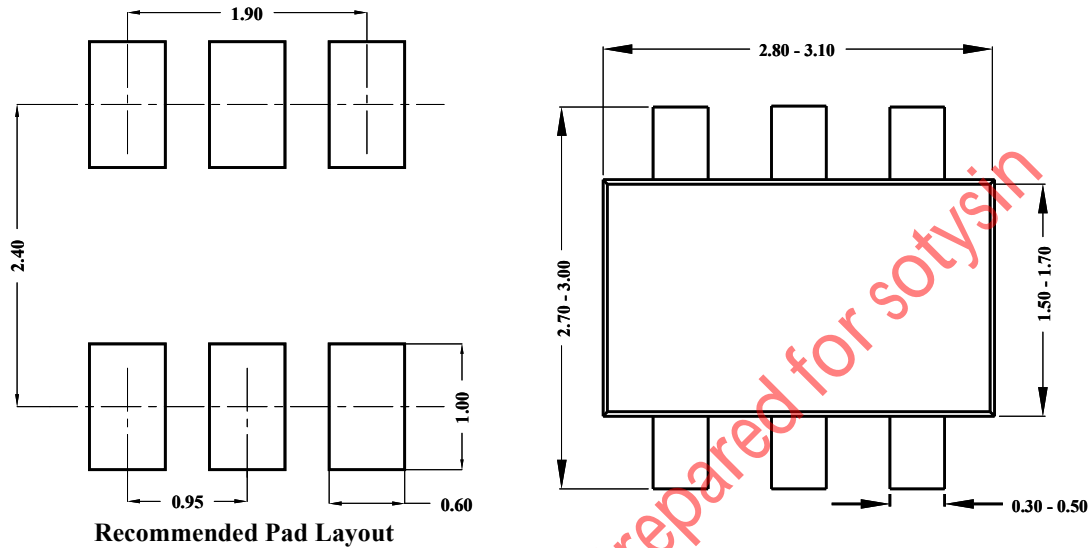

**Notes: All dimensions are in millimeters.
All dimensions don't include mold flash & metal burr.**

Taping & Reel Specification

1. Taping orientation

SOT23-6

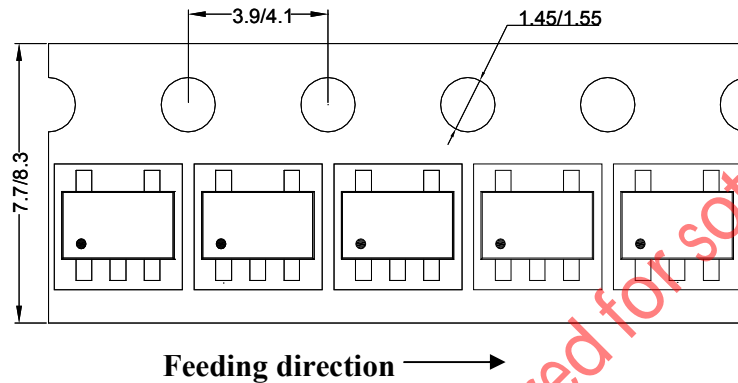

2. Carrier Tape & Reel specification for packages

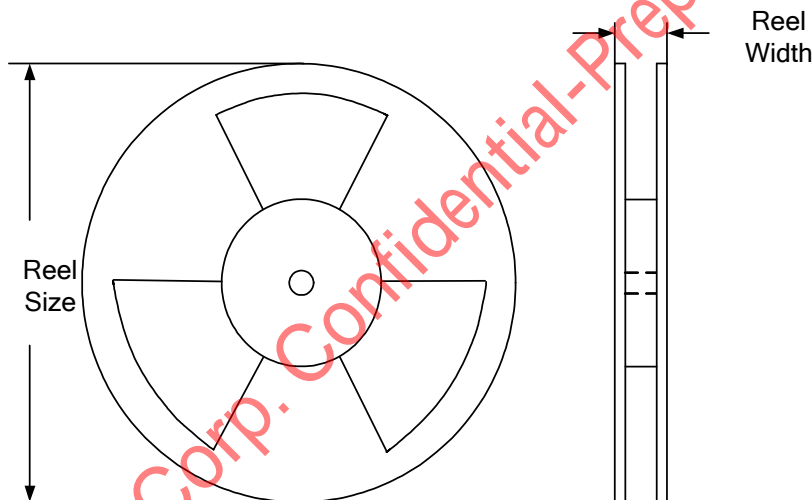

Package types	Tape width (mm)	Pocket pitch(mm)	Reel size (Inch)	Reel width(mm)	Trailer length(mm)	Leader length (mm)	Qty per reel
SOT23-6	8	4	7"	8.4	280	160	3000

3. Others: NA