

Synchronous Boost,Buck DC/DC Regulator AM1008

Features

- Synchronous rectification: Up to 95% efficiency
- Single inductor
- Fixed frequency operation with battery voltages above, below or equal to the output
- Quiescent current: 300 μ A
- Up to 600mA continuous output current
- 1.8V to 5.5V input and output voltage range
- Programmable oscillator frequency from 350kHz to 1.5MHz
- No Shottky Diodes required
- V_{OUT} disconnected from V_{IN} during shutdown
- Shutdown current: $I_Q < 1\mu$ A
- Package: small thermally enhanced 10-pin MSOP

Application

- Digital cameras and Wireless handsets
- Palmtop computers
- MP3/MP4 players
- Handheld instruments

Typical Applications

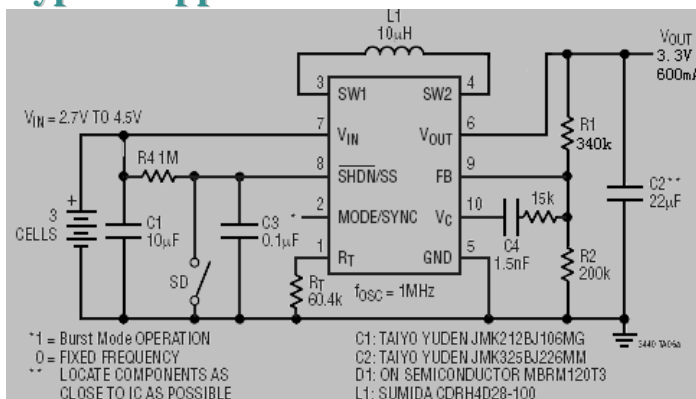

Description

The AM1008 is high efficiency, fixed frequency, Buck-Boost DC/DC converters which operates from input voltages above, below or equal to the output voltage. The devices are suitable for single lithium-ion, multicell alkaline or NiMH applications where the output voltage is within the battery voltage range.

The switching frequencies up to 1.5 MHz could be fixed by employing an external resistor, and the oscillator could be synchronized to an external clock. the quiescent current is 300 μ A, and this feature maximizing the battery life in portable applications.

Other features include a 1 μ A shutdown, soft-start control, thermal shutdown and current limit. The AM1008 converters are available in the 10-pin thermally enhanced MSOP packages (or upon request).

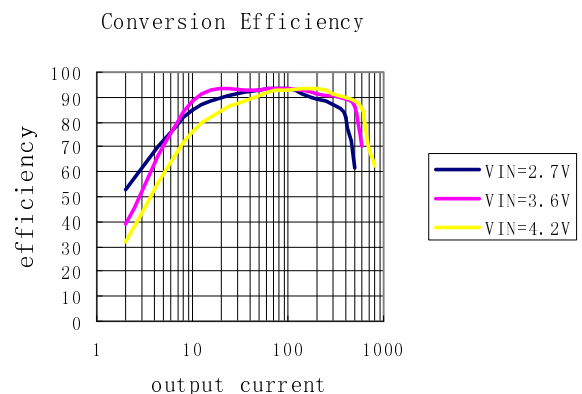

Absolute Maximum Ratings

- V_{IN} - 0.3 V ~ + 6 V
- $V_{RT,FB,SHDN/SS, SYNC}$ - 0.3 V ~+ 6 V
- V_{SW} - 0.3 V ~ + 6 V
- V_{OUT}- 0.3 V ~ + 6 V
- Operating Temperature Range- 40°C ~ + 85°C
- Lead Temperature (Soldering 10 sec.)+ 300°C
- Storage Temperature Range- 65°C ~ + 150°C

Pin Assignment

PIN NUMBER MSOP-10	PIN NAME	FUNCTION
1	R_0	
2	MS	MODE/SYNC
3	S1	Switch 1
4	S2	Switch 2
5	GND	Ground
6	V_{OUT}	Output
7	V_{IN}	Input
8	EN	ON/OFF Control (High Enable)
9	V_{FB}	Feedback
10	COMP	

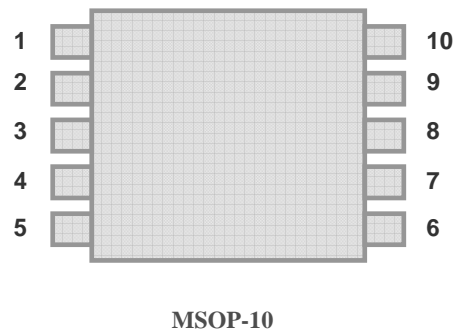

Electrical Characteristics

Operating Conditions: $T_A=25^{\circ}\text{C}$, $V_{IN}=V_{OUT}=3.6\text{V}$ unless otherwise specified.

PARAMETER	CONDITIONS		MIN	TYP	MAX	UNITS
Input Start-Up Voltage		●		1.8	1.9	V
Input Operating Range		●	1.8		5.5	V
Output Voltage Adjust Range		●	2.5		5.5	V
Feedback Voltage		●	1.200 1.22	1.212		V
Feedback Input Current	$V_{FB}=1.212\text{V}$			1	50	nA
Quiescent Current, Shutdown	$EN=0\text{V}$, Not Including Switch Leakage			0.1	1	uA
Quiescent Current, Active	$VC=0\text{V}$, $SYNC=0\text{V}$			600	1000	uA
NMOS Switch Leakage	Switches B and C			0.1	5	uA
PMOS Switch Leakage	Switches A and D			0.1	10	uA
NMOS Switch On Resistance	Switches B and C			0.19		Ω
PMOS Switch On Resistance	Switches A and D			0.22		Ω
Input Current Limit		●	1			A
Maximum Duty Cycle	Boost (% Switch C On) Buck (% Switch A On)	●	55 100	75		% %
Minimum Duty Cycle		●			0	%
Frequency Accuracy		●	0.8	1	1.2	MHZ
SYNC Threshold			0.4		2	V
SYNC Input Current	$V_{SYNC}=5.5\text{V}$			0.01	1	uA
Error Amp AVOL				90		dB
Error Amp Source Current				15		uA
Error Amp Sink Current				380		V
EN Threshold	When IC is Enabled When EA is at Maximum Boost Duty Cycle	●	0.4	1 2.2	1.5	V V
EN Input Current	$V_{EN}=5.5\text{V}$			0.01	1	uA

Typical Performance Characteristics

Li-Ion to 3.2V Efficiency
(fosc=967KHZ)

Li-Ion to 3.2V Efficiency
(fosc=666KHZ)

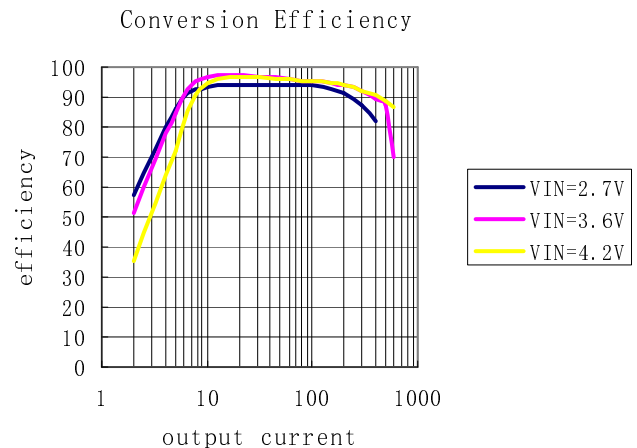
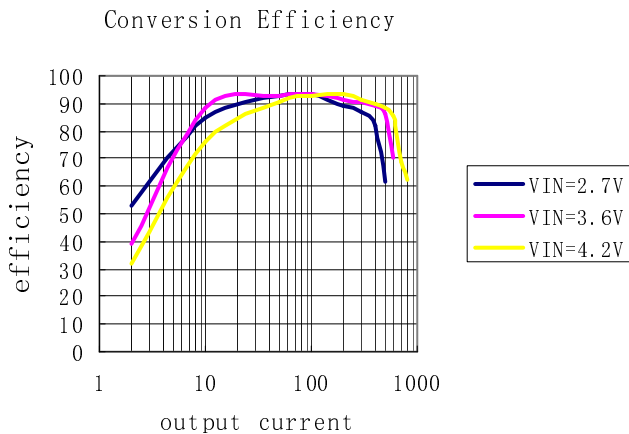

Application Information

R₀ (Pin 1): Timing Resistor to Program the Oscillator Frequency. The programming frequency range is 300kHz to 2MHz

$$f_{osc} = \frac{6 \cdot 10^{10}}{R_T} \text{ Hz}$$

SYNC (Pin 2): SYNC = External CLK : Synchronization of the internal oscillator. A clock frequency of twice the desired switching frequency and with a pulse width between 100ns and 2μs is applied. The oscillator free running frequency is set slower than the desired synchronized switching frequency to guarantee sync. The oscillator RT component value required is given by:

$$R_T = \frac{8 \cdot 10^{10}}{f_{SW}} \quad \text{where } f_{SW} = \text{desired synchronized switching frequency.}$$

SW1 (Pin 3): Switch Pin Where the Internal Switches A and B are Connected. Connect inductor from SW1 to SW2. An optional Schottky diode can be connected from SW1 to ground. Minimize trace length to keep EMI down.

SW2 (Pin 4): Switch Pin Where the Internal Switches C and D are Connected. For

applications with output voltages over 4.3V, a Schottky diode is required from SW2 to VOUT to ensure the SW pin does not exhibit excess voltage.

GND (Pin 5): Signal and Power Ground for the IC.

V_{OUT} (Pin 6): Output of the Synchronous Rectifier. A filter capacitor is placed from VOUT to GND.

V_{IN} (Pin 7): Input Supply Pin. Internal VCC for the IC. A ceramic bypass capacitor as close to the VIN pin and GND(Pin 5) is required.

EN (Pin 8): Combined Soft-Start and Shutdown. Grounding this pin shuts down the IC. Tie to >1.5V to enable the IC and > 1.8V to ensure the error amp is not clamped from soft-start. An RC from the shutdown command signal to this pin will provide a soft-start function by limiting the rise time of the VC pin.

FB (Pin 9): Feedback Pin. Connect resistor divider tap here. The output voltage can be adjusted from 2.5V to 5.5V. The feedback reference voltage is typically 1.212V.

COMP(Pin 10): Error Amp Output. A frequency compensation network is connected from this pin to the FB pin to compensate the loop.

Functional Diagram

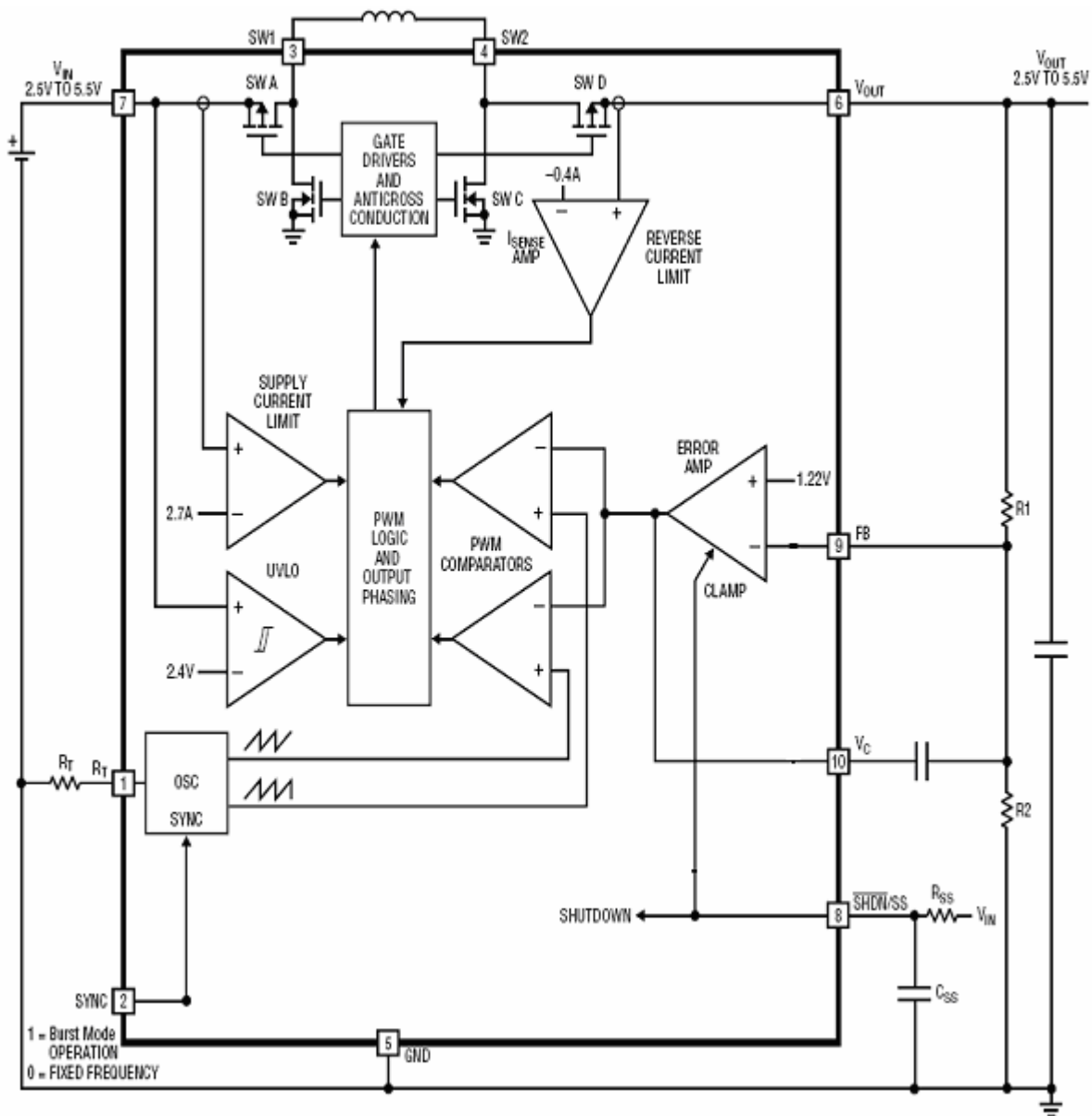

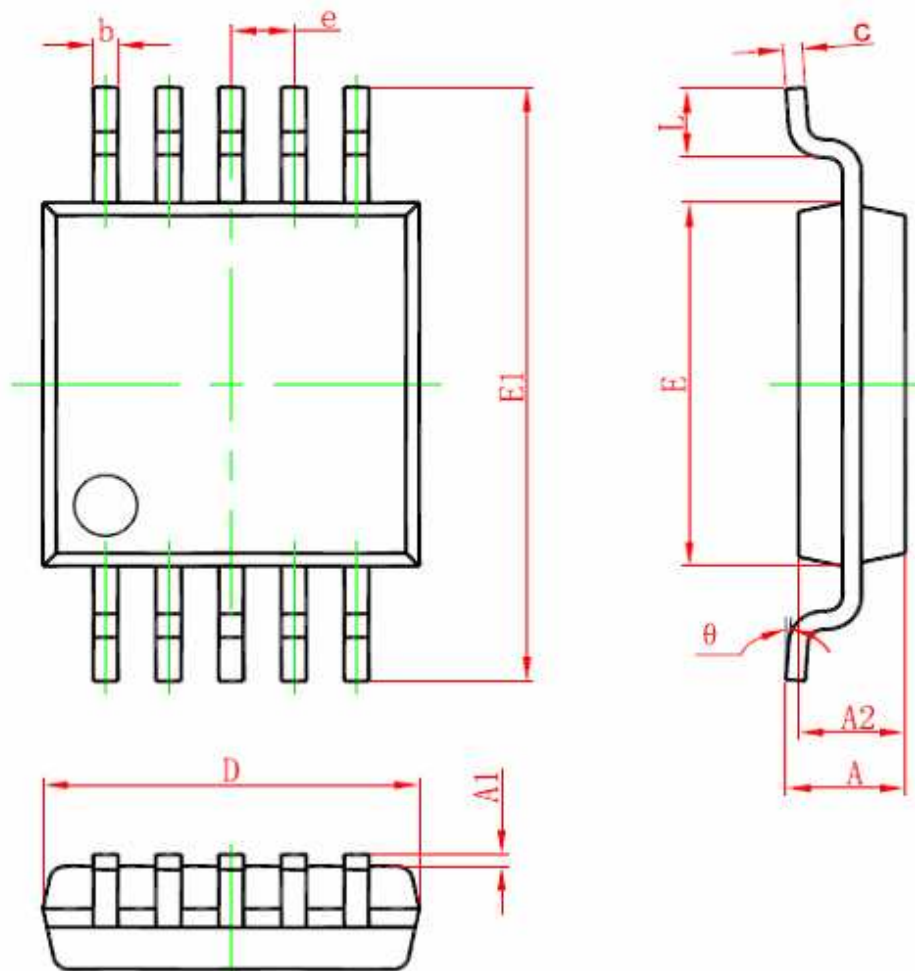
Packaging Information
MSOP-10 Package Outline Dimen

Symbol	Dimensions In Millimeters		Dimensions In Inches	
	Min	Max	Min	Max
A	0.820	1.100	0.032	0.043
A1	0.020	0.150	0.001	0.006
A2	0.750	0.950	0.030	0.037
b	0.180	0.280	0.007	0.011
c	0.090	0.230	0.004	0.009
D	2.900	3.100	0.114	0.122
e	0.50(BSC)		0.020(BSC)	
E	2.900	3.100	0.114	0.122
E1	4.750	5.050	0.187	0.199
L	0.400	0.800	0.016	0.031
θ	0°	6°	0°	6°